

# ISO Standard (15552)

## Air Cylinder: Standard Type Double Acting, Single/Double Rod

# CP96 Series

ø32, ø40, ø50, ø63, ø80, ø100



RoHS

The CP96 series, standard type, ø125 is the same as the previous model. For details, refer to the **Web Catalog**.

### How to Order

**CP96S** **B** **32** - **100** **C** **J** **W** - [ ]

**With auto switch** **CP96SD** **B** **32** - **100** **C** **J** **W** - **M9BW** **S** - [ ]

**With auto switch** (Built-in magnet)

**Mounting**

<b>B</b>	Basic
<b>L</b>	Axial foot
<b>F</b>	Rod flange
<b>G</b>	Head flange
<b>C</b>	Single clevis
<b>D</b>	Double clevis

\* Mounting brackets are shipped together, but not assembled.

**Bore size**

<b>32</b>	32 mm
<b>40</b>	40 mm
<b>50</b>	50 mm
<b>63</b>	63 mm
<b>80</b>	80 mm
<b>100</b>	100 mm

**Cylinder stroke [mm]**  
Refer to "Standard Strokes" on page 130.

**Air cushion on both ends + Bumper cushion**

**Rod boot**

<b>Nil</b>	Without rod boot
<b>J</b>	Nylon tarpaulin (One end)
<b>JJ</b>	Nylon tarpaulin (Both ends)
<b>K</b>	Heat-resistant tarpaulin (One end)
<b>KK</b>	Heat-resistant tarpaulin (Both ends)

**Number of auto switches**

<b>Nil</b>	2
<b>S</b>	1
<b>3</b>	3
<b>n</b>	n

**Auto switch**

<b>Nil</b>	Without auto switch
------------	---------------------

\* For applicable auto switches, refer to the table below.

**Rod**

<b>Nil</b>	Single rod
<b>W</b>	Double rod

**Made to Order**  
Refer to page 130 for details.

### Applicable Auto Switches/Refer to the Web Catalog or Best Pneumatics for further information on auto switches.

Type	Special function	Electrical entry	Indicator light	Wiring (Output)	Load voltage		Auto switch model	Lead wire length [m]				Pre-wired connector	Applicable load					
					DC	AC		0.5 (Nil)	1 (M)	3 (L)	5 (Z)							
Solid state auto switch	—	Grommet	No	3-wire (NPN)	24 V	5 V, 12 V	—	<b>M9N</b>	●	●	●	○	○	IC circuit	Relay, PLC			
				3-wire (PNP)				<b>M9P</b>	●	●	●	○	○					
				2-wire				<b>M9B</b>	●	●	●	○	○					
	Diagnostic indication (2-color indicator)	Grommet	Yes	3-wire (NPN)	24 V	5 V, 12 V	—	<b>M9NW</b>	●	●	●	○	○	IC circuit				
				3-wire (PNP)				<b>M9PW</b>	●	●	●	○	○					
				2-wire				<b>M9BW</b>	●	●	●	○	○					
	Water-resistant (2-color indicator)	Grommet	No	3-wire (NPN)	24 V	5 V, 12 V	—	<b>M9NA</b> *1	○	○	●	○	○	IC circuit				
				3-wire (PNP)				<b>M9PA</b> *1	○	○	●	○	○					
				2-wire				<b>M9BA</b> *1	○	○	●	○	○					
Reed auto switch	—	Grommet	Yes	3-wire (NPN equivalent)	24 V	5 V	100 V	<b>A96</b>	●	—	●	—	—	IC circuit	—			
				2-wire				12 V	100 V or less	<b>A93</b>	●	●	●			●	—	—
										<b>A90</b>	●	—	●			—	—	

\*1 Water-resistant type auto switches can be mounted on the above models, but SMC cannot guarantee water resistance.

\* Lead wire length symbols: 0.5 m ..... Nil (Example) M9NW  
1 m ..... M (Example) M9NWM  
3 m ..... L (Example) M9NWL  
5 m ..... Z (Example) M9NWX

\* Solid state auto switches marked with "○" are produced upon receipt of order.

\* Since there are other applicable auto switches than listed above, refer to page 146 for details.

\* The D-A9□/M9□/M9□W/M9□A auto switches are shipped together, but not assembled. (Only the auto switch mounting brackets are assembled before shipment.)

\* The D-Y59A, Y69A, Y7P, Y7□W, Z7□, Z80 cannot be mounted on the CP96 series.

Moreover, the D-M9□□ and A9□ auto switches cannot be mounted on square groove of the CP96 series.

ISO Standard (15552) Air Cylinder: Standard Type **CP96 Series**  
 Double Acting, Single/Double Rod

**Specifications**

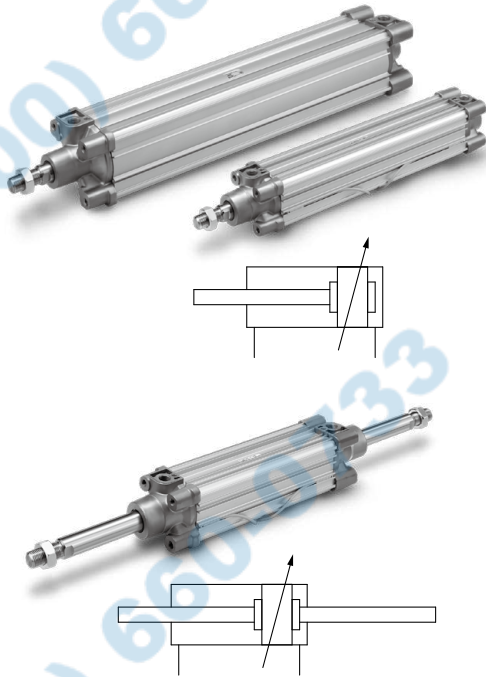

Bore size [mm]	32	40	50	63	80	100
<b>Action</b>	Double acting					
<b>Fluid</b>	Air					
<b>Proof pressure</b>	1.5 MPa					
<b>Max. operating pressure</b>	1.0 MPa					
<b>Min. operating pressure</b>	0.05 MPa					
<b>Ambient and fluid temperature</b>	Without auto switch: -20 to 70°C (No freezing) With auto switch: -10 to 60°C (No freezing)					
<b>Lubrication</b>	Not required (Non-lube)					
<b>Operating piston speed</b>	50 to 1000 mm/s					
<b>Allowable stroke tolerance</b>	Up to 500 stroke: ${}^{+2}_0$ , 501 to 1000 stroke: ${}^{+2.4}_0$ , 1001 to 1500 stroke: ${}^{+2.8}_0$ , 1501 to 2000 stroke: ${}^{+3.2}_0$					
<b>Cushion</b>	Air cushion on both ends + Bumper cushion					
<b>Port size</b>	G 1/8	G 1/4	G 1/4	G 3/8	G 3/8	G 1/2
<b>Mounting</b>	Basic, Axial foot, Rod flange, Head flange, Single clevis, Double clevis					

**Standard Strokes**

Bore size [mm]	Standard stroke [mm]	Max. stroke*1
32	25, 50, 80, 100, 125, 160, 200, 250, 320, 400, 500	2000
40	25, 50, 80, 100, 125, 160, 200, 250, 320, 400, 500	2000
50	25, 50, 80, 100, 125, 160, 200, 250, 320, 400, 500, 600	2000
63	25, 50, 80, 100, 125, 160, 200, 250, 320, 400, 500, 600	2000
80	25, 50, 80, 100, 125, 160, 200, 250, 320, 400, 500, 600, 700, 800	2000
100	25, 50, 80, 100, 125, 160, 200, 250, 320, 400, 500, 600, 700, 800	2000

Intermediate strokes are available.  
 \*1 Please consult with SMC for longer strokes.

**Accessories**

**Made to Order**  
 (For details, refer to pages 148 to 155.)

Symbol	Specifications
-XA□	Change of rod end shape
-XB6	Heat-resistant cylinder (-10 to 150°C)
-XC4	With heavy duty scraper
-XC7	Tie-rod, tie-rod nut, etc. made of stainless steel
-XC10	Dual stroke cylinder/Double rod type
-XC11	Dual stroke cylinder/Single rod type
-XC22	Fluororubber seal
-XC35	With coil scraper
-XC65	Made of stainless steel (Combination of -XC7 and -XC68)
-XC68	Made of stainless steel (with hard chrome plated piston rod)
-XC88	Spatter-resistant coil scraper, Lube-retainer, grease for welding (Piston rod: Stainless steel 304)
-XC89	Spatter-resistant coil scraper, Lube-retainer, grease for welding (Piston rod: S45C)

Mounting		Basic	Foot	Rod flange	Head flange	Single clevis	Double clevis
Standard	Rod end nut	●	●	●	●	●	●
	Clevis pin	—	—	—	—	—	●
Option	Rod end	●	●	●	●	●	●
	Rod clevis	●	●	●	●	●	●
	Rod boot	●	●	●	●	●	●

\* Do not use a rod end (or floating joint) together with a single clevis with a ball joint (or clevis pivot bracket with a ball joint).  
 \* Refer to pages 137 to 140 for dimensions and part numbers of the accessories.

Refer to pages 145 and 146 for cylinders with auto switches.

- Auto Switch Proper Mounting Position (Detection at stroke end)
- Minimum Stroke for Auto Switch Mounting
- Operating Range
- How to Mount and Move the Auto Switch

**⚠ Precautions**

Be sure to read this before handling the products. Refer to page 219 for safety instructions. For actuator and auto switch precautions, refer to the "Handling Precautions for SMC Products" and the "Operation Manual" on the SMC website: <http://www.smcworld.com>

C85  
C85W  
C85-ST  
C85K  
C85K-ST  
C85R  
C75  
C75W  
C75-ST  
C75K  
C75K-ST  
C75R  
CP96  
CP96K  
C96  
C96K  
C96Y  
C55  
Auto Switch  
Made to Order  
Related Products