

Air Cylinder

New

RoHS

Double foot Head flange
Double-side bossed are
added to the
mounting types.

4 types → 7 types

Improved amount of
mounting freedom

Head cover with
boss is added.

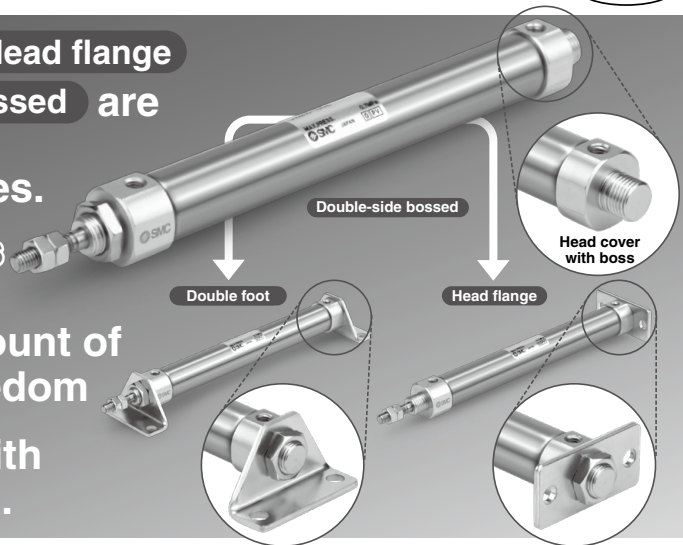

Air Cylinders

CJ2
CM2
CG1
MB
CA2
CQ2
CQS
Lube-retainer
JA
MXH
MXJ
MGP
CY
CX
CK01
C(L)□
C(L)XU
CKQ
CKZ2N
WRF

Easy fine adjustment of auto switch position

Fine adjustment of the auto switch position is possible by simply loosening the screw attached to the auto switch.

Transparent switch bracket improves visibility of indicator LED.

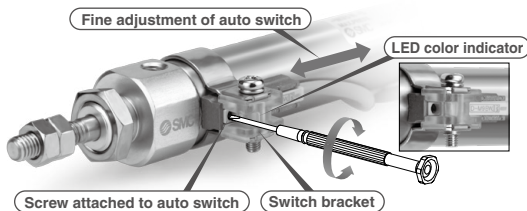

Rod end deflection accuracy improved

Rod end deflection is reduced by mounting a wear ring to the piston as standard.

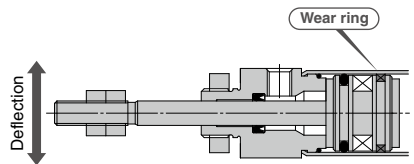

Series CJ2



Part numbers with rod end bracket and/or pivot bracket available

Not necessary to order a bracket for the applicable cylinder separately

(Note) Mounting bracket is shipped together with the product, but not assembled.

Example) CDJ2D16-50Z- **N W** -M9BW-B

Pivot bracket	
Nil	None
N	Pivot bracket is shipped together with the product, but not assembled.

* Only for C.J2D (double clevis) type

N: Kit of pivot bracket and double clevis

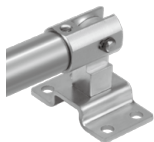

Rod end bracket	
Nil	None
V	Single knuckle joint
W	Double knuckle joint
T	Rod end cap (Flat type)
U	Rod end cap (Round type)

With rod end bracket
V: Single knuckle joint



W: Double knuckle joint



Rod end cap
T: Flat type



U: Round type



Various mounting bracket options

- Suitable mounting brackets can be selected for the installation condition.
- Improved amount of mounting freedom

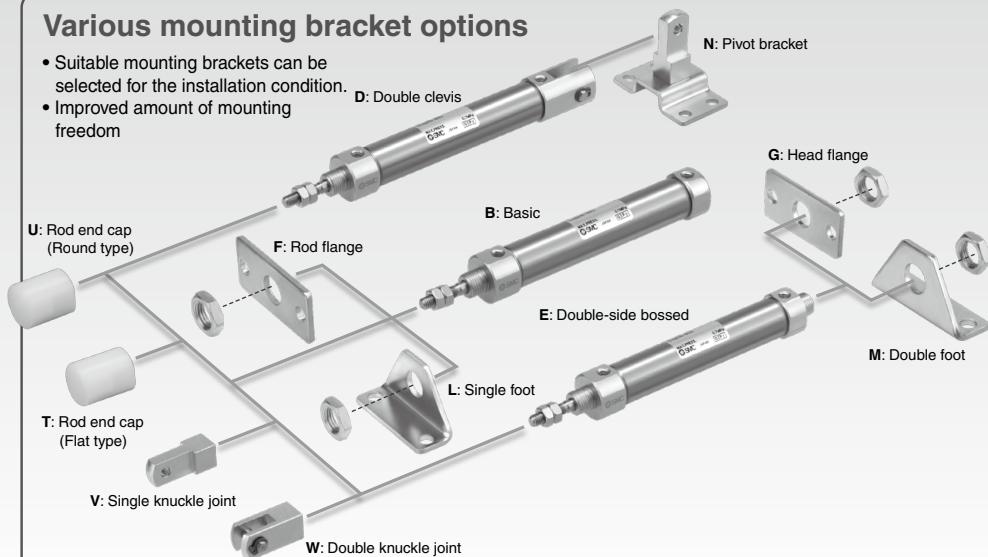

2 mounting types of compact auto switches

- **Band mounting**
- **Rail mounting**

The auto switch mounting type, band or rail can be selected with the model number.

Water resistant compact auto switch now available

- **Solid state auto switch D-M9□A(V)**

Applicable to lead wire perpendicular entry type



Band mounting

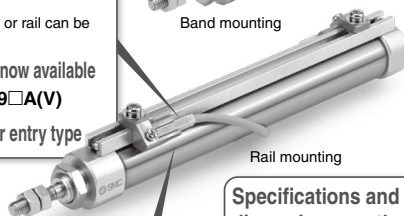

Rail mounting

Head cover

4 types of head cover shape are available.

Basic	Double clevis
Axial piping	With boss

No environmental hazardous substances used

Specifications and dimensions are the same as the existing product.

Easy fine adjustment of auto switch position

Fine adjustment of the auto switch set position can be performed by loosening the auto switch attached screw without loosening the auto switch mounting band. Operability improved compared with the conventional auto switch set position adjustment, where the complete switch mounting band requires loosening.

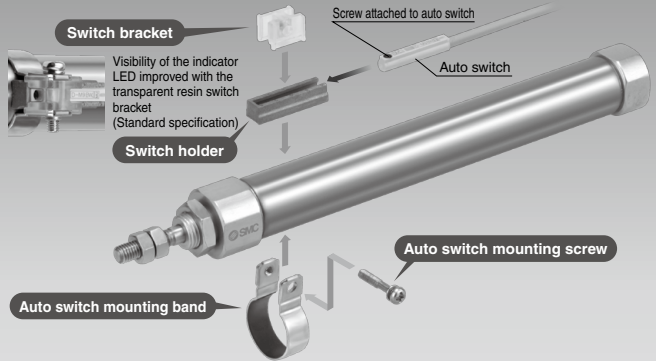

Stroke Variations

Bore size (mm)	Standard stroke									
	15	30	45	60	75	100	125	150	175	200
6	●	●	●	●	●	●	●	●	●	●
10	●	●	●	●	●	●	●	●	●	●
16	●	●	●	●	●	●	●	●	●	●

Series Variations

Series	Action	Type	Bore size (mm)			Variations		Page
			6	10	16	Built-in magnet	Air cushion	
Standard CJ2	Double acting	Single rod	●			●		Page 361
	Double acting	Double rod	●			●		Page 377
	Single acting	Single rod Spring return/extend	●			●		Page 385
Standard CJ2-Z	Double acting	Single rod		●	●			Page 362
	Double acting	Double rod		●	●		●	Page 378
	Single acting	Single rod Spring return/extend		●	●		●	Page 386
Non-rotating rod CJ2K-Z	Double acting	Single rod		●	●			Page 399
	Single acting	Single rod Spring return/extend		●	●			Page 406
Built-in speed controller CJ2Z-Z	Double acting	Single rod		●	●			Page 418
	Double acting	Double rod		●	●			Page 425
Direct mount CJ2R-Z	Double acting	Single rod		●	●			Page 430
	Single acting	Single rod Spring return/extend		●	●			Page 434
Direct mount, Non-rotating rod CJ2RK-Z	Double acting	Single rod		●	●			Page 438
	Single acting	Single rod Spring return/extend		●	●			Page 441
With end lock CBJ2	Double acting	Single rod		●	●			Page 445
Smooth Cylinder CJ2Y-Z	Double acting	Single rod		●	●			CAT.ES20-235
Low Speed Cylinder CJ2X-Z	Double acting	Single rod		●	●			CAT.ES20-235

* The standard type with bore size of 6 mm and the air cylinder with end lock have the same shapes as the existing products.

* For details about the clean series, refer to the WEB catalog.

Air Cylinders
CJ2
CM2
CG1
MB
CA2
CQ2
CQS
Lube-retainer
JA
MXH
MXQ
MGP
CY
CX
CK1
CLK
CLKU
CKQ
CKZN
WRF
INDEX

Combinations of Standard Products and Made to Order Specifications

Series CJ2

- : Standard
- : Made to Order
- : Special product (Please contact SMC for details.)
- : Not available

Series	CJ2 (Standard type)				CJ2K (Non-rotating rod type)			
	Double acting		Single acting		Double acting	Single acting		
	Single rod	Double rod	Single rod (spring return)	Single rod (spring extend)	Single rod	Single rod (spring return)	Single rod (spring extend)	
Action/ Type								
Page	Page 361	Page 377	Page 385		Page 399	Page 406		

Symbol	Specifications	Applicable bore size	ø6 ^{Note 7)} to ø16				ø10, ø16			
Standard	Standard	ø6 ^{Note 7)} to ø16	●	●	●	●	●	●	●	
D	Built-in magnet		●	●	●	●	●	●	●	
CJ2□-□A	Air cushion	ø10, ø16	●	●	—	—	—	—	—	
10-, 11-	Clean series ^{Note 1)}	ø6 ^{Note 7)} to ø16	●	● ^{Note 11)}	○	○	—	—	—	
25A-	Copper (Cu) and Zinc (Zn)-free ^{Note 6)}	ø10, ø16	●	○	○	○	○	○	○	
20-	Copper ^{Note 10)} and Fluorine-free ^{Note 2)}	ø6 ^{Note 7)} 12)	●	●	●	●	—	—	—	
XB6	Heat resistant cylinder (–10 to 150°C) ^{Note 3)} 4)	ø6 ^{Note 7)} to ø16	○	○	○	○	○	○	○	
XB7	Cold resistant cylinder (–40 to 70°C) ^{Note 3)} 4)		○	○	○	○	○	○	○	
XB9	Low speed cylinder (10 to 50 mm/s) ^{Note 4)}		○	—	—	—	—	—	—	
XB13	Low speed cylinder (5 to 50 mm/s)	ø6 ^{Note 7)}	○	—	—	—	—	—	—	
XC3	Special port position ^{Note 2)} 4)	ø10, ø16	○	○	—	—	○	—	—	
XC8	Adjustable stroke cylinder/ Adjustable extension type ^{Note 4)}		○	—	○	○	○	○	○	
XC9	Adjustable stroke cylinder/ Adjustable retraction type ^{Note 4)}		○	—	○	—	○	○	—	
XC10	Dual stroke cylinder/Double rod type ^{Note 4)}		○	—	○	○	○	○	○	
XC11	Dual stroke cylinder/Single rod type ^{Note 4)}		○	—	—	—	○	—	—	
XC22	Fluororubber seal ^{Note 4)}		ø6 ^{Note 7)} to ø16	○	○	○	○	○	○	○
XC51	With hose nipple	○		○	○	○	○	○	○	
XC85	Grease for food processing equipment	ø10, ø16	○	○	○	○	○	○	○	
X446	PTFE grease		○	○	○	○	○	○	○	
X773	Short pitch mounting	ø6 ^{Note 7)}	—	—	○	—	—	—	—	

Note 1) Mounting style: Not compatible with the clevis type.

Note 2) An auto switch is available in the band mounting type only.

Note 3) The products with an auto switch are not compatible.

Note 4) The products with an air cushion are not compatible.

Note 5) For details about the smooth cylinder and low speed cylinder,

refer to the **WEB catalog** or "ES20-235" catalog.

Note 6) For details, refer to the **WEB catalog**.

Note 7) The shape is the same as the existing product.

Note 8) Available only for locking at head end.

Note 9) Available only for locking at rod end.

Note 10) Copper is not allowed to use for the externally exposed part.

Note 11) ø10 and ø16 only

Note 12) Available as standard for ø10 and ø16.

CJ2Z (Built-in speed controller type)		CJ2R (Direct mount type)			CJ2RK (Direct mount, Non-rotating rod type)			CBJ2 (With end lock) ^{Note 7)}	CJ2Y ^{Note 5)} Smooth Cylinder	CJ2X ^{Note 5)} Low Speed Cylinder	Symbol
Double acting		Double acting	Single acting		Double acting	Single acting		Double acting	Double acting	Double acting	
Single rod	Double rod	Single rod	Single rod (spring return)	Single rod (spring extend)	Single rod	Single rod (spring return)	Single rod (spring extend)	Single rod	Single rod	Single rod	
Page 418	Page 425	Page 430	Page 434		Page 438	Page 441		Page 445	—	—	
ø10, ø16								ø16	ø10, ø16	ø10, ø16	
●	●	●	●	●	●	●	●	●	●	●	Standard
●	●	●	●	●	●	●	●	●	●	●	D
—	—	○	—	—	—	—	—	—	—	—	CJ2□-□A
—	—	●	○	○	—	—	—	○ ^{Note 8)}	—	—	10-, 11-
○	○	○	○	○	○	○	○	○	○	○	25A-
—	—	—	—	—	—	—	—	—	—	—	20-
○	○	○	○	○	○	○	○	○	—	—	XB6
○	○	○	○	○	○	○	○	○	—	—	XB7
—	—	—	—	—	—	—	—	○	—	—	XB9
—	—	—	—	—	—	—	—	—	—	—	XB13
—	—	○	—	—	○	—	—	○	◎	○	XC3
○	—	○	○	○	○	○	○	—	—	—	XC8
—	—	◎	○	—	◎	○	—	○ ^{Note 9)}	◎	—	XC9
○	—	○	○	○	○	○	○	○	○	—	XC10
—	—	○	—	—	○	—	—	○ ^{Note 9)}	—	—	XC11
○	○	◎	○	○	○	○	○	○	—	—	XC22
◎	◎	◎	◎	◎	◎	◎	◎	—	—	—	XC51
◎	◎	◎	◎	◎	◎	◎	◎	—	—	—	XC85
◎	◎	◎	◎	◎	◎	◎	◎	—	—	—	X446
—	—	—	—	—	—	—	—	—	—	—	X773

Air Cylinders
CJ2
CM2
CG1
MB
CA2
CQ2
CQS
Lube-retainer
JA
MXH
MXQ
MGP
C□Y
C□X
CK□1
C(L)K□
C(L)KU
CKQ
CKZ2N
WRF

Air Cylinder: Standard Type Double Acting, Single Rod Series CJ2



ø6

How to Order

CJ2 **L 6** - **60** **R** - **□**

With auto switch **CDJ2** **L 6** - **60** **R** - **M9BW** **□** - **C** - **□**

With auto switch (Built-in magnet)

Mounting

B	Basic
L	Single foot
F	Rod flange

Bore size

6	6 mm
---	------

Cylinder standard stroke (mm)
Refer to "Standard Strokes" on page 363.

Built-in Magnet Cylinder Model
Suffix the symbol "B" (Band mounting style) to the end of part number for cylinder with auto switch.

Example	Band mounting	CDJ2B6-60-B
---------	---------------	-------------

Head cover port location

R	Axial
---	-------

* ø6 is available only as in-line style.

Made to Order
Refer to page 363 for details.

Auto switch mounting bracket (Note)
Note) This symbol is indicated when the D-A9□ or M9□ type auto switch is specified. This mounting bracket does not apply to other auto switches (D-C7□ and H7□, etc.) (Nil)

Number of auto switches

Nil	2 pcs.
S	1 pc.
n	"n" pcs.

Auto switch
* For applicable auto switches, refer to the table below.
★ If a built-in magnet cylinder without an auto switch is required, refer to the model of built-in magnet cylinder.

Applicable Auto Switches/Refer to the WEB catalog or the Best Pneumatics No. 2 for further information on auto switches.

Type	Special function	Electrical entry	Indicator light	Wiring (Output)	Load voltage		Auto switch model		Lead wire length (m)					Pre-wired connector	Applicable load				
					DC	AC	Perpendicular	In-line	0.5 (Nil)	1 (M)	3 (L)	5 (Z)	None (N)						
Solid state auto switch	—	Grommet	Yes	3-wire (NPN)	5 V, 12 V	—	M9NV	M9N	●	●	●	○	—	○	IC circuit				
				3-wire (PNP)			M9PV	M9P	●	●	●	○	—						
		2-wire		M9BV			M9B	●	●	●	○	—	—						
		—		H7C			●	—	●	●	—	—							
	Diagnostic indication (2-color indication)	Grommet	Yes	3-wire (NPN)	24 V	—	M9NVV	M9NV	●	●	●	○	—	○	IC circuit				
				3-wire (PNP)			M9PVV	M9PV	●	●	●	○	—						
		2-wire		M9BVV			M9BW	●	●	●	○	—	—						
		—		H7NF			●	—	●	●	—	—							
Water resistant (2-color indication)	Grommet	Yes	3-wire (NPN)	5 V, 12 V	—	M9NAV***	M9NA***	○	○	●	○	—	○	IC circuit					
			3-wire (PNP)			M9PAV***	M9PA***	○	○	●	○	—							
With diagnostic output (2-color indication)	Grommet	Yes	2-wire	12 V	—	M9BAV***	M9BA***	○	○	●	○	—	○	IC circuit					
			4-wire (NPN)			—	H7NF	●	—	●	●	—	—						
Reed auto switch	—	Grommet	Yes	3-wire (NPN equivalent)	5 V	—	A96V	A96	●	—	—	—	—	○	IC circuit				
				—			—	—	●	—	●	—	—	—					
				—			—	—	●	—	●	—	—	—					
		Connector		No			2-wire	24 V	12 V	—	A93V	A93	●	—	●	—	—	—	IC circuit
											A90V	A90	●	—	●	—	—	—	
											—	C73C	●	—	●	●	—	—	
Yes	No	—	—	—	—	—	C80C	●	—	●	●	—	—	IC circuit					
						—	—	●	—	●	●	—	—						

*** Water resistant type auto switches can be mounted on the above models, but in such case SMC cannot guarantee water resistance.

Please contact SMC regarding water resistant types with the above model numbers.

* Lead wire length symbols: 0.5 m..... Nil (Example) M9NW
1 m..... M (Example) M9NWM
3 m..... L (Example) M9NWL
5 m..... Z (Example) M9NWZ
None..... N (Example) H7CN

* Since there are other applicable auto switches than listed above, refer to page 460 for details.

* For details about auto switches with pre-wired connector, refer to the WEB catalog or the Best Pneumatics No. 2.

* Solid state auto switches marked with "○" are produced upon receipt of order.

* The D-A9□□/M9□□□ auto switches are shipped together, (but not assembled). (However, only the auto switch mounting brackets are assembled before shipment.)

Air Cylinder: Standard Type Double Acting, Single Rod Series CJ2

ø10, ø16



How to Order

CJ2 B 16 - 60 A Z - - - -

With auto switch **CDJ2 B 16 - 60 A Z - - - - M9BW - B - - - -**

With auto switch (Built-in magnet)

Mounting

B	Basic
E	Double-side bossed
D	Double clevis
L	Single foot
M	Double foot
F	Rod flange
G	Head flange

Cylinder standard stroke (mm)
Refer to "Standard Strokes" on page 363.

10	10 mm
16	16 mm

Bore size

Pivot bracket

Nil	None
N	Pivot bracket is shipped together with the product, but not assembled.

* Only for CJ2D (double clevis)
* Pivot bracket is shipped together with the product, but not assembled.

Made to Order
Refer to page 363 for details.

Auto switch mounting type

A	Rail mounting
B	Band mounting

* For rail mounting, screws and nuts for 2 auto switches come with the rail.
* Refer to page 459 auto switch mounting brackets.

Number of auto switches

Nil	2 pcs.
S	1 pc.
n	"n" pcs.

Auto switch

Nil	Without auto switch
-----	---------------------

* For applicable auto switches, refer to the table below.

Rod end bracket

Nil	None
V	Single knuckle joint
W	Double knuckle joint
T	Rod end cap (Flat type)
U	Rod end cap (Round type)

* Rod end bracket is shipped together with the product, but not assembled.
* A knuckle joint pin is not provided with the single knuckle joint.

Cushion

Nil	Rubber bumper
A	Air cushion

Head cover port location

Nil	Perpendicular to axis
R	Axial

* Foot/Flange brackets are shipped together with the product, but not assembled.

* For double clevis, the product is perpendicular to the cylinder axis.
* For double-side bossed, the product is perpendicular to the cylinder axis.

* Refer to "Ordering Example of Cylinder Assembly" on page 363.

Applicable Auto Switches/Refer to the WEB catalog or the Best Pneumatics No. 2 for further information on auto switches.

Type	Special function	Electrical entry	Indicator light	Wiring (Output)	Load voltage		Auto switch model				Lead wire length (m)					Pre-wired connector	Applicable load
					DC	AC	Band mounting		Rail mounting		(Nil)	1 (M)	3 (L)	5 (Z)	None (N)		
							Perpendicular	In-line	Perpendicular	In-line							
Solid state auto switch	—	Grommet	—	3-wire (NPN)	5 V, 12 V	—	M9NV	M9N	M9NV	M9N	●	●	●	○	○	IC circuit	
				3-wire (PNP)			M9PV	M9P	M9PV	M9P	●	●	●	○	○		
		Connector	—	—	2-wire	12 V	—	M9BV	M9B	M9BV	M9B	●	●	●	○	○	—
					—			H7C	J79C	—	●	—	●	●	—	—	
	Diagnostic indication (2-color indication)	—	Grommet	Yes	3-wire (NPN)	5 V, 12 V	—	M9NWV	M9NW	M9NWV	M9NW	●	●	●	○	○	IC circuit
					3-wire (PNP)			M9PWV	M9PW	M9PWV	M9PW	●	●	●	○	○	
		Water resistant (2-color indication)	—	Grommet	—	3-wire (NPN)	5 V, 12 V	—	M9NAV**	M9NA**	M9NAV**	M9NA**	○	○	○	○	IC circuit
						3-wire (PNP)			M9PAV**	M9PA**	M9PAV**	M9PA**	○	○	○	○	
Reed auto switch	—	Grommet	Yes	3-wire (NPN equivalent)	5 V	—	A96V	A96	A96V	A96	●	—	—	—	—	IC circuit	
				—			—	—	A72	A72H	●	—	—	—	—		
				—			200 V	—	—	—	—	—	—	—	—		—
				—			100 V	A93V	A93	A93V	A93	●	—	●	—		—
Diagnostic indication (2-color indication)	—	Connector	No	2-wire	24 V	12 V	100 V or less	A90V	A90	A90V	A90	●	—	●	—	IC circuit	
							—	—	C73C	A73C	—	●	—	●	—		
							24 V or less	—	C80C	A80C	—	●	—	●	—		
							—	—	—	A79W	—	●	—	●	—		

** Water resistant type auto switches can be mounted on the above models, but in such case SMC cannot guarantee water resistance. Please contact SMC regarding water resistant types with the above model numbers.

* Lead wire length symbols: 0.5 m..... Nil (Example) M9NW
1 m..... M (Example) M9NWM
3 m..... L (Example) M9NWL
5 m..... Z (Example) M9NWX
None..... N (Example) H7CN

* Since there are other applicable auto switches than listed above, refer to page 460 for details.
* For details about auto switches with pre-wired connector, refer to the WEB catalog or the Best Pneumatics No. 2.
* Solid state auto switches marked with "○" are produced upon receipt of order.
* The D-A900/M9000/A700/A800/F700/J700 auto switches are shipped together, (but not assembled). (For band mounting, only the auto switch mounting brackets are assembled before shipment.)



- Air Cylinders
- CJ2
- CM2
- CG1
- MB
- CA2
- CQ2
- CQS
- Lube-retainer
- JA
- MXH
- MXQ
- MGP
- CY
- CX
- CK1
- CLK
- CLJKU
- CKQ
- CKZ2N
- WRF
- INDEX

Series CJ2



Symbol

Rubber bumper

Air cushion

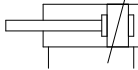
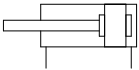

Made to Order

(For details, refer to pages 463 to 472.)

Symbol	Specifications
-XA□	Change of rod end shape
-XB6	Heat resistant cylinder (-10 to 150°C) * Not available with switch & with air cushion
-XB7	Cold resistant cylinder (-40 to 70°C) * Not available with switch & with air cushion
-XB9	Low speed cylinder (10 to 50 mm/s) * Not available with air cushion
-XB13 ^(N600)	Low speed cylinder (5 to 50 mm/s) * Not available with air cushion
-XC3	Special port location * Not available with air cushion
-XC8	Adjustable stroke cylinder/Adjustable extension type
-XC9	Adjustable stroke cylinder/Adjustable retraction type
-XC10	Dual stroke cylinder/Double rod type
-XC11	Dual stroke cylinder/Single rod type
-XC22	Fluororubber seal * Not available with air cushion
-XC51	With hose nipple
-XC85	Grease for food processing equipment
-X446	PTFE grease

Note) ø6 only

Ordering Example of Cylinder Assembly

Cylinder model:

CDJ2D16-60Z-NW-M9BW-B

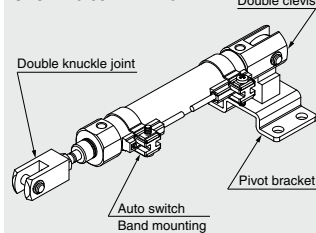

Mounting D: Double clevis
 Pivot bracket N: Yes
 Rod end bracket W: Double knuckle joint
 Auto switch D-M9BW: 2 pcs.
 Auto switch mounting B: Band mounting

* Pivot bracket, double knuckle joint and auto switch are shipped together with the product, but not assembled.

* Except ø6.

Specifications

Bore size (mm)		6	10	16
Action		Double acting, Single rod		
Fluid		Air		
Proof pressure		1 MPa		
Maximum operating pressure		0.7 MPa		
Minimum operating pressure	Rubber bumper	0.12 MPa	0.06 MPa	
	Air cushion	—	0.1 MPa	
Ambient and fluid temperature		Without auto switch: -10°C to 70°C (No freezing) With auto switch: -10°C to 60°C		
Cushion		Rubber bumper	Rubber bumper/Air cushion	
Lubrication		Not required (Non-lube)		
Piston speed	Rubber bumper	50 to 750 mm/s		
	Air cushion	50 to 1000 mm/s		
Allowable kinetic energy	Rubber bumper	0.012 J	0.035 J	0.090 J
	Air cushion (Effective cushion length)	—	0.07 J (9.4 mm)	0.18 J (9.4 mm)
Stroke length tolerance		+1.0 0		

Standard Strokes

Bore size	Standard stroke		Maximum manufacturable stroke (mm)
	6	10	
6	15, 30, 45, 60	—	200
10	15, 30, 45, 60, 75, 100, 125, 150	—	400
16	15, 30, 45, 60, 75, 100, 125, 150, 175, 200	—	400

* Manufacture of intermediate strokes at 1 mm intervals is possible. (Spacers are not used.)
 Produced upon receipt of order.

* Applicable strokes should be confirmed according to the usage. For details, refer to "Air Cylinders Model Selection" on front matter pages of the Best Pneumatics No. 2 or the **WEB catalog**. In addition, the products that exceed the standard stroke might not be able to fulfill the specifications due to the deflection etc.

Mounting and Accessories

●---Mounted on the product. ○---Can be ordered within the cylinder model.

Mounting		Basic	Foot	Flange	Double* clevis	Double clevis (including T-bracket)
Standard	Mounting nut	●	●	●	—	—
	Rod end nut	●	●	●	●	●
	Clevis pin	—	—	—	●	●
Option	Single knuckle joint	○	○	○	○	○
	Double knuckle joint*	○	○	○	○	○
	Rod end cap (Flat/Round type)	○	○	○	○	○
	T-bracket	—	—	—	○	●

* A pin and retaining rings are included with double clevis and/or double knuckle joint.

Mounting Brackets/Part No.

Mounting bracket	Bore size (mm)		
	6	10	16
Foot	CJ-L006B	CJ-L010C	CJ-L016C
Flange	CJ-F006B	CJ-F010C	CJ-F016C
T-bracket*	—	CJ-T010C	CJ-T016C

* T-bracket is used with double clevis (D).

Refer to pages 453 to 460 for cylinders with auto switches.

- Auto switch proper mounting position (detection at stroke end) and its mounting height
- Minimum stroke for auto switch mounting
- Operating range
- Auto switch mounting brackets/Part no.

Moisture Control Tube Series IDK



When operating an actuator with a small diameter and a short stroke at a high frequency, the dew condensation (water droplet) may occur inside the piping depending on the conditions.

Simply connecting the moisture control tube to the actuator will prevent dew condensation from occurring. For details, refer to **Series IDK in the WEB catalog**.

Weights

Bore size (mm)		Rubber bumper			Air cushion	
		6	10	16	10	16
Basic weight (When the stroke is zero)	Basic	15	22	46	39	66
	Axial piping	15	22	46	39	66
	Double clevis (including clevis pin)	—	24	54	43	74
	Head-side bossed	—	23	48	40	68
Additional weight per 15 mm of stroke		2	4	7	4	7
Mounting bracket weight	Single foot	8	8	25	8	25
	Double foot	—	16	50	16	50
	Rod flange	5	5	13	5	13
	Head flange	—	5	13	5	13
Accessories	Single knuckle joint	—	17	23	17	23
	Double knuckle joint (including knuckle pin)	—	25	21	25	21
	Rod end cap (Flat type)	1	1	2	1	2
	Rod end cap (Round type)	1	1	2	1	2
	T-bracket	—	32	50	32	50



Precautions

Refer to page 473 before handling.

* Mounting nut and rod end nut are included in the basic weight.

Note) Mounting nut is not included in the basic weight for the double clevis.

Calculation:

Example) **CJ2L10-45Z**

- Basic weight 22 (ø10)
 - Additional weight 4/15 stroke
 - Cylinder stroke 45 stroke
 - Mounting bracket weight 8 (Axial foot)
- 22 + 4/15 x 45 + 8 = 42 g

Clean Series

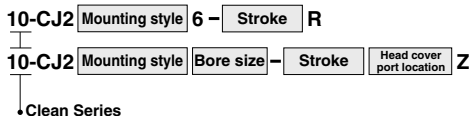

Air cylinder which is applicable for the system which discharges leakage from the rod section directly into the outside of clean room by relief port and making an actuator's rod section having a double seal construction.



Specifications

Action	Double acting, Single rod	
Bore size (mm)	6, 10, 16	
Maximum operating pressure	0.7 MPa	
Minimum operating pressure	ø6	0.14 MPa
	ø10, ø16	0.08 MPa
Cushion	Rubber bumper/Air cushion	
Standard stroke (mm)	Same as standard type. (Refer to page 363.)	
Auto switch	Mountable (Band mounting type)	
Mounting	Basic, Double-side bossed*, Single/Double foot*, Rod/Head flange*	

* ø10 and ø16 only

Construction

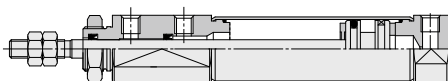

* The above figure is for ø16.

For the detailed specifications, refer to the "Pneumatic Clean Series" (WEB catalog).

Low Speed Cylinder

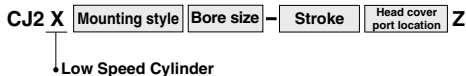

Smooth operation with a little sticking and slipping at low speed. Can start smoothly with a little ejection even after being rendered for hours.



The dimensions are the same as the double acting, single rod type.

Specifications

Action	Double acting, Single rod	
Bore size (mm)	10, 16	
Fluid	Air	
Proof pressure	1.05 MPa	
Maximum operating pressure	0.7 MPa	
Minimum operating pressure	0.06 MPa	
Ambient and fluid temperature	Without auto switch: -10 to 70°C (No freezing) With auto switch: -10 to 60°C	
Cushion	Rubber bumper (Standard equipment)	
Lubrication	Not required (Non-lube)	
Stroke length tolerance	+1.0 0	
Piston speed	1 to 300 mm/s	
Allowable kinetic energy	ø10	0.035 J
	ø16	0.090 J

For details, refer to the WEB catalog or "ES20-235" catalog.

Series CJ2

Construction (Not able to disassemble)

CJ2□6

Rubber bumper

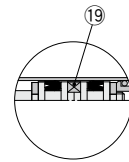
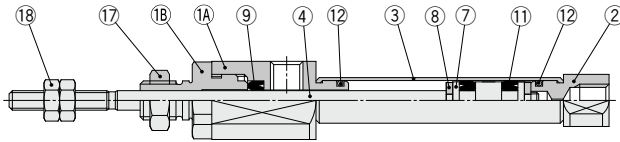

With auto switch

CJ2□10, CJ2□16

Rubber bumper

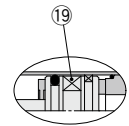
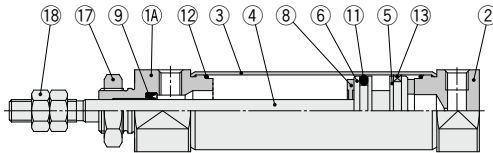

With auto switch

Air cushion

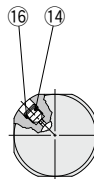
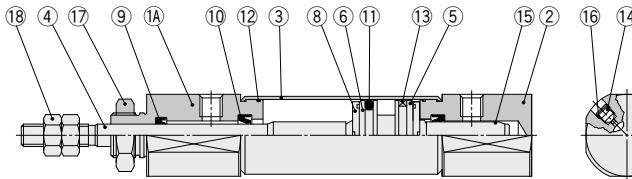

With auto switch

Component Parts

No.	Description	Material	Note
1A	Rod cover	Aluminum alloy	Anodized
1B	Seal retainer	Aluminum alloy	Anodized (ø6 only)
2	Head cover	Aluminum alloy	Anodized
3	Cylinder tube	Stainless steel	
4	Piston rod	Stainless steel	
5	Piston A	Aluminum alloy	ø10, ø16
6	Piston B	Aluminum alloy	ø10, ø16
7	Piston	Brass	ø6
8	Bumper	Urethane	
9	Rod seal	NBR	

No.	Description	Material	Note
10	Cushion seal	NBR	
11	Piston seal	NBR	
12	Tube gasket	NBR	
13	Wear ring	Resin	ø10, ø16
14	Cushion needle	Carbon steel	
15	Cushion ring	Aluminum alloy	
16	Needle seal	NBR	
17	Mounting nut	Rolled steel	Zinc chromated
18	Rod end nut	Rolled steel	Zinc chromated
19	Magnet	—	

Dimensions

Basic (B)

CJ2B6 – **Stroke** R

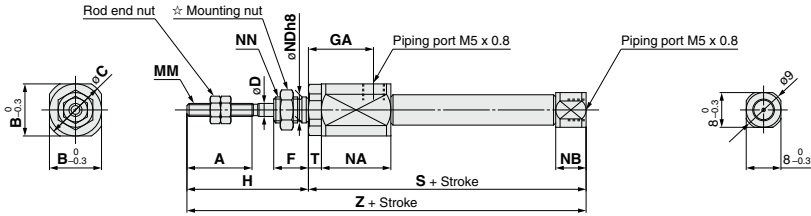

CJ2B **Bore size** – **Stroke** **Head cover port location** Z

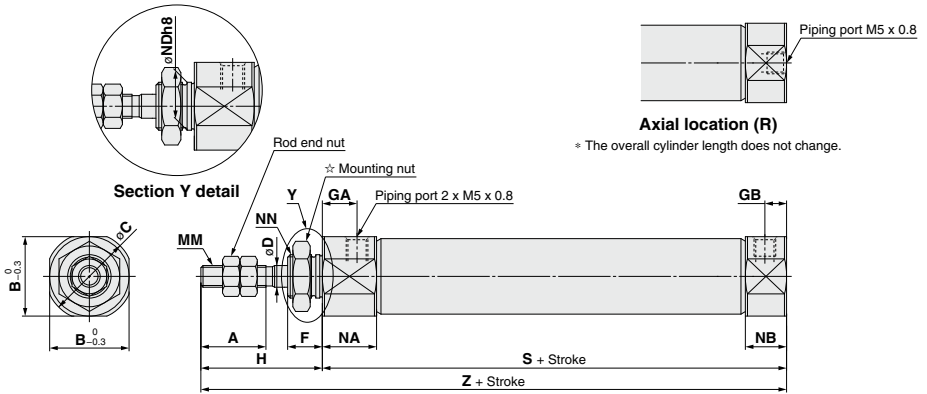

☆ For details of the mounting nut, refer to page 376.

Bore size	A	B	C	D	F	GA	GB	H	MM	NA	NB	NDh8	NN	S	T	Z
6	15	12	14	3	8	14.5	—	28	M3 x 0.5	16	7	6 ⁰ / _{-0.018}	M6 x 1.0	49	3	77
10	15	12	14	4	8	8	5	28	M4 x 0.7	12.5	9.5	8 ⁰ / _{-0.022}	M8 x 1.0	46	—	74
16	15	18.3	20	5	8	8	5	28	M5 x 0.8	12.5	9.5	10 ⁰ / _{-0.022}	M10 x 1.0	47	—	75

(mm)

Air Cylinders

CJ2

CM2

CG1

MB

CA2

CQ2

CQS

Lube-retainer

JA

MXH

MXQ

MGP

C□Y

C□X

CK□1

C(L)□

C(L)KU

CKQ

CKZ2N

WRF

INDEX

Series CJ2

Dimensions

Basic (B)

With air cushion: **CJ2B** Bore size – Stroke **A** Head cover port location **Z**

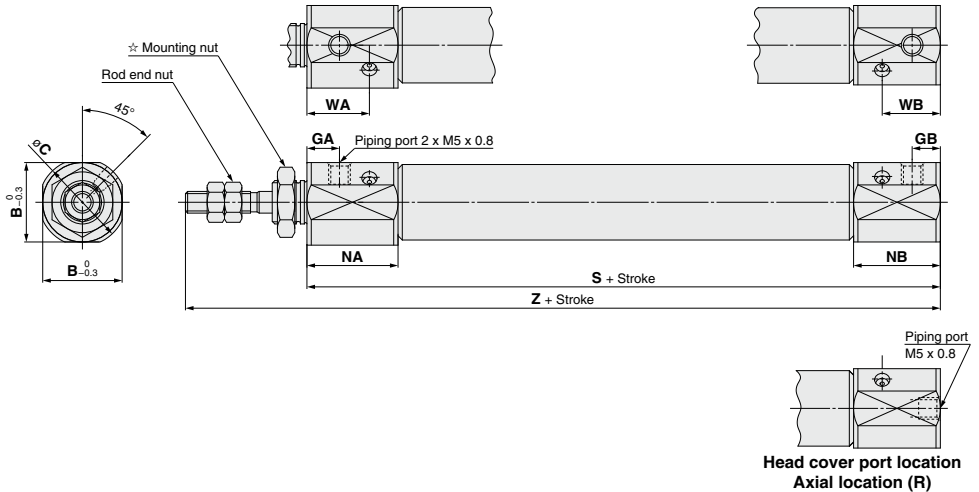

☆ For details of the mounting nut, refer to page 376.

Dimensions other than the table below are the same as those on page 366. (mm)

Bore size	B	C	GA	GB	NA	NB	WA	WB	S	Z
10	15	17	7.5	6.5	21	20	14.4	13.4	65	93
16	18.3	20	7.5	6.5	21	20	14.4	13.4	66	94

Dimensions

Single foot (L)

CJ2L6 – Stroke R

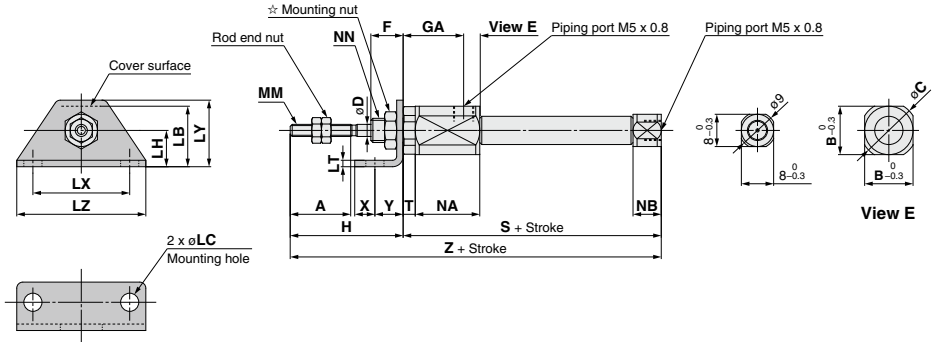

CJ2L Bore size – Stroke Head cover port location Z

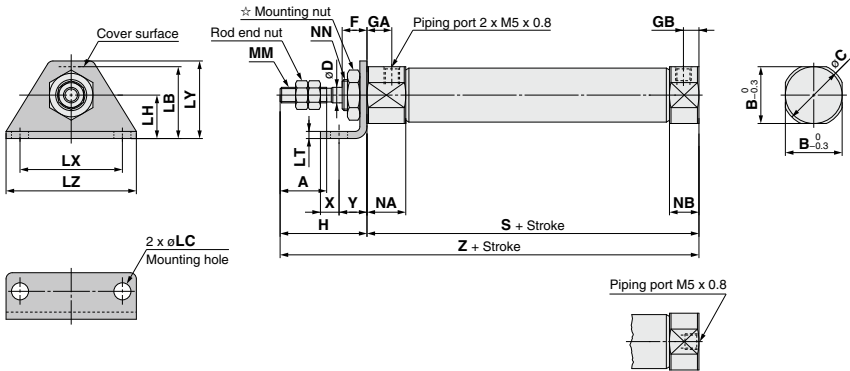

**Head cover port location
Axial location (R)**

* The overall cylinder length does not change.

☆ For details of the mounting nut, refer to page 376.

Bore size	A	B	C	D	F	GA	GB	H	LB	LC	LH	LT	LX	LY	LZ	MM	NA	NB	NN	S	T	X	Y	Z
6	15	12	14	3	8	14.5	—	28	15	4.5	9	1.6	24	16.5	32	M3 x 0.5	16	7	M6 x 1.0	49	3	5	7	77
10	15	12	14	4	8	8	5	28	15	4.5	9	1.6	24	16.5	32	M4 x 0.7	12.5	9.5	M8 x 1.0	46	—	5	7	74
16	15	18.3	20	5	8	8	5	28	23	5.5	14	2.3	33	25	42	M5 x 0.8	12.5	9.5	M10 x 1.0	47	—	6	9	75

Air Cylinders

CJ2

CM2

CG1

MB

CA2

CQ2

CQS

Lube-retainer

JA

MXH

MXQ

MGP

C□Y

C□X

CK□1

C(L)□

C(L)KU

CKQ

CKZ2N

WRF

INDEX

Series CJ2

Dimensions

Single foot (L)

With air cushion: CJ2L **Bore size** – **Stroke** **A** **Head cover port location** **Z**

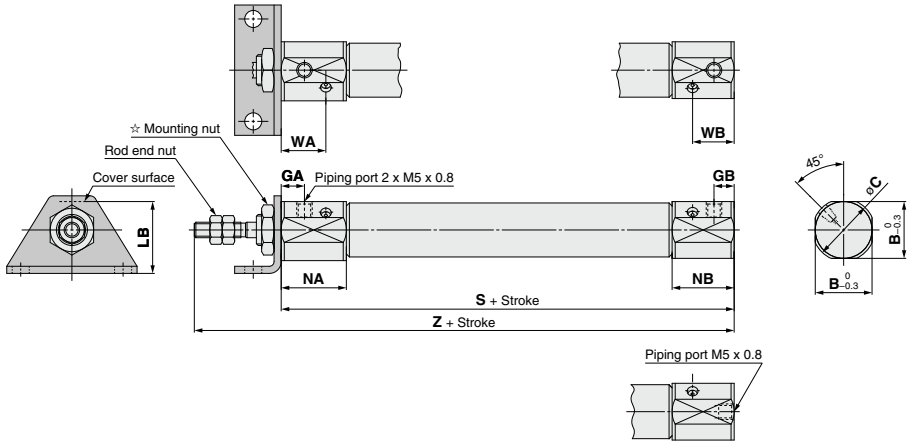

Head cover port location Axial location (R)

* The overall cylinder length does not change.

☆ For details of the mounting nut, refer to page 376.

Dimensions other than the table below are the same as those on page 368. (mm)

Bore size	B	C	GA	GB	LB	NA	NB	WA	WB	S	Z
10	15	17	7.5	6.5	16.5	21	20	14.4	13.4	65	93
16	18.3	20	7.5	6.5	23	21	20	14.4	13.4	66	94

Dimensions

Double foot (M)

CJ2M Bore size – Stroke Z

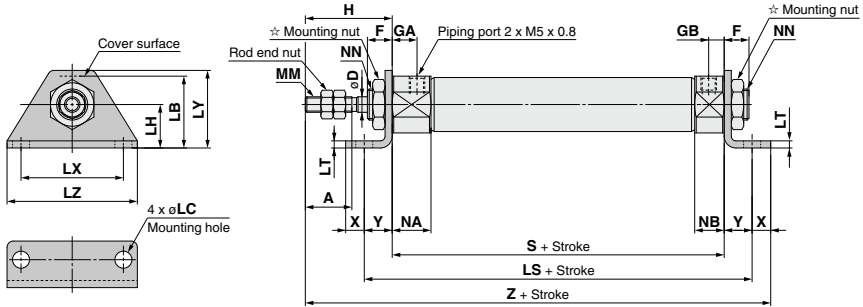

With air cushion: CJ2M Bore size – Stroke AZ

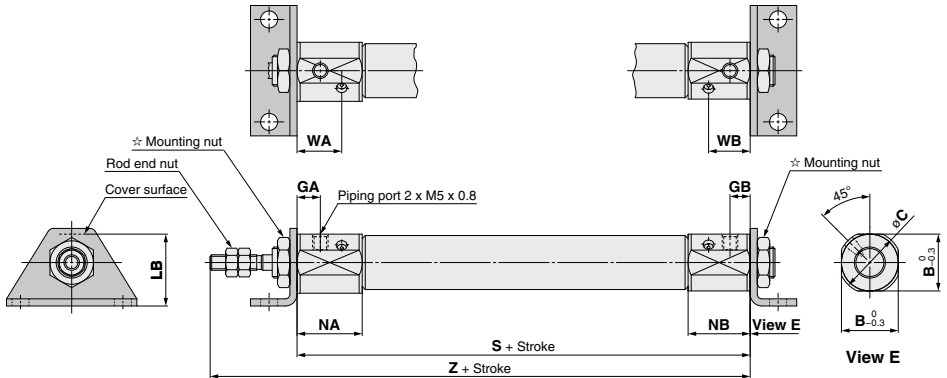

☆ For details of the mounting nut, refer to page 376.

Bore size	A	D	F	GA	GB	H	LB	LC	LH	LS	LT	LX	LY	LZ	MM	NA	NB	NN	S	X	Y	Z
10	15	4	8	8	5	28	15	4.5	9	60	1.6	24	16.5	32	M4 x 0.7	12.5	9.5	M8 x 1.0	46	5	7	86
16	15	5	8	8	5	28	23	5.5	14	65	2.3	33	25	42	M5 x 0.8	12.5	9.5	M10 x 1.0	47	6	9	90

With Air Cushion Dimensions other than the table below are the same as the table above. (mm)

Bore size	B	C	GA	GB	LB	NA	NB	WA	WB	S	Z
10	15	17	7.5	6.5	16.5	21	20	14.4	13.4	65	93
16	18.3	20	7.5	6.5	23	21	20	14.4	13.4	66	94

Air Cylinders

CJ2

CM2

CG1

MB

CA2

CQ2

CQS

Lube-retainer

JA

MXH

MXQ

MGP

Y

X

CK1

C(L)K

C(L)KU

CKQ

CKZ2N

WRF

INDEX

Series CJ2

Dimensions

Rod flange (F)

CJ2F6 – Stroke R

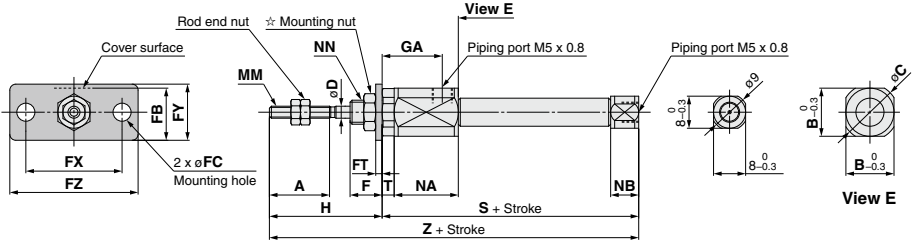

CJ2F Bore size – Stroke Head cover port location Z

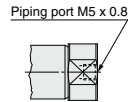
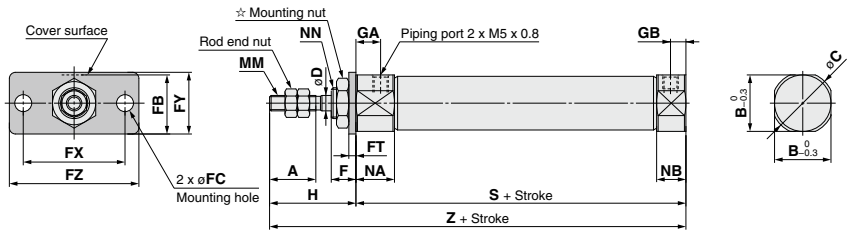

Head cover port location Axial location (R)

* The overall cylinder length does not change.

☆ For details of the mounting nut, refer to page 376.

Bore size	A	B	C	D	F	FB	FC	F	FT	FX	FY	FZ	GA	GB	H	MM	NA	NB	NN	S	T	Z
6	15	12	14	3	8	13	4.5	1.6	24	14	32	14.5	—	28	M3 x 0.5	16	7	M6 x 1.0	49	3	77	
10	15	12	14	4	8	13	4.5	1.6	24	14	32	8	5	28	M4 x 0.7	12.5	9.5	M8 x 1.0	46	—	74	
16	15	18.3	20	5	8	19	5.5	2.3	33	20	42	8	5	28	M5 x 0.8	12.5	9.5	M10 x 1.0	47	—	75	

Dimensions

Rod flange (F)

With air cushion: CJ2F **Bore size** – **Stroke** **A** **Head cover port location** **Z**

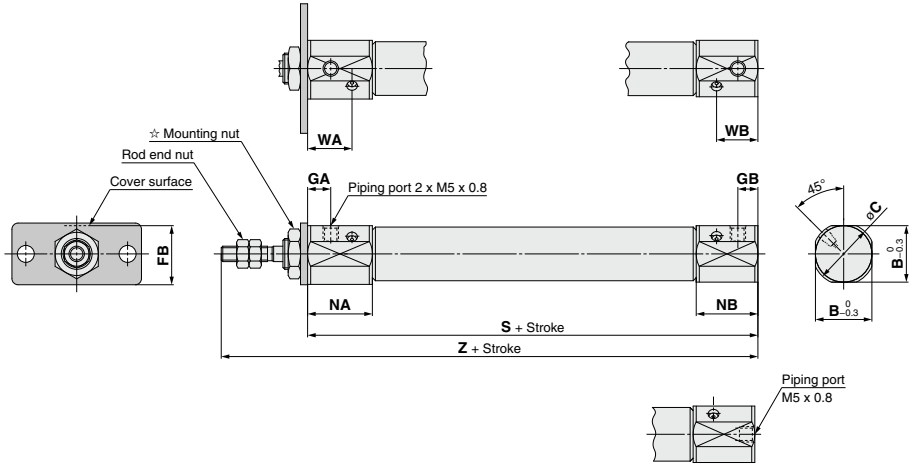

Head cover port location
Axial location (R)

* The overall cylinder length does not change.

☆ For details of the mounting nut, refer to page 376.

Dimensions other than the table below are the same as those on page 371. (mm)

Bore size	B	C	FB	GA	GB	NA	NB	WA	WB	S	Z
10	15	17	14.5	7.5	6.5	21	20	14.4	13.4	65	93
16	18.3	20	19	7.5	6.5	21	20	14.4	13.4	66	94

Air Cylinders

CJ2

CM2

CG1

MB

CA2

CQ2

CQS

Lube-

retainer

JA

MXH

MXQ

MGP

C□Y

C□X

CK□1

C(L)□

C(L)XU

CKQ

CKZZN

WRF

INDEX

Series CJ2

Dimensions

Head flange (G)

CJ2G Bore size – Stroke Z

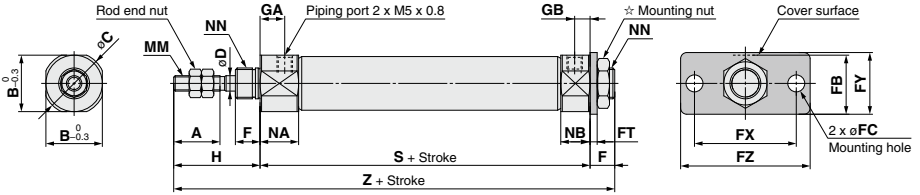

With air cushion: CJ2G Bore size – Stroke AZ

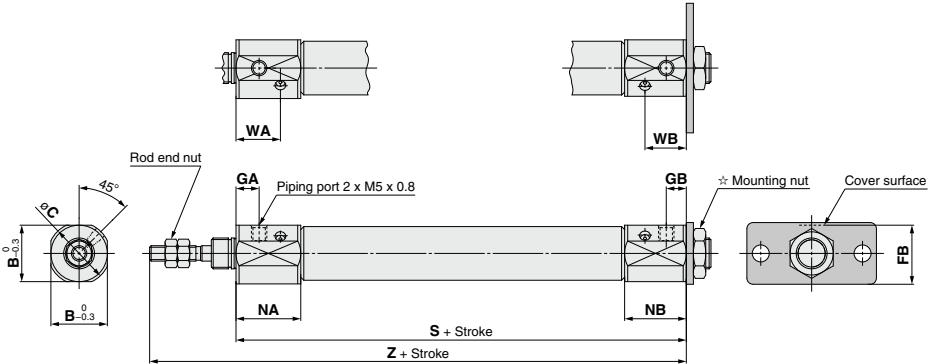

☆ For details of the mounting nut, refer to page 376.

Bore size	A	B	C	D	F	FB	FC	FT	FX	FY	FZ	GA	GB	H	MM	NA	NB	NN	S	Z
10	15	12	14	4	8	13	4.5	1.6	24	14	32	8	5	28	M4 x 0.7	12.5	9.5	M8 x 1.0	46	82
16	15	18.3	20	5	8	19	5.5	2.3	33	20	42	8	5	28	M5 x 0.8	12.5	9.5	M10 x 1.0	47	83

With Air Cushion Dimensions other than the table below are the same as the table above. (mm)

Bore size	B	C	FB	GA	GB	NA	NB	WA	WB	S	Z
10	15	17	14.5	7.5	6.5	21	20	14.4	13.4	65	93
16	18.3	20	19	7.5	6.5	21	20	14.4	13.4	66	94

Dimensions

Double clevis (D)

CJ2D Bore size – Stroke Z

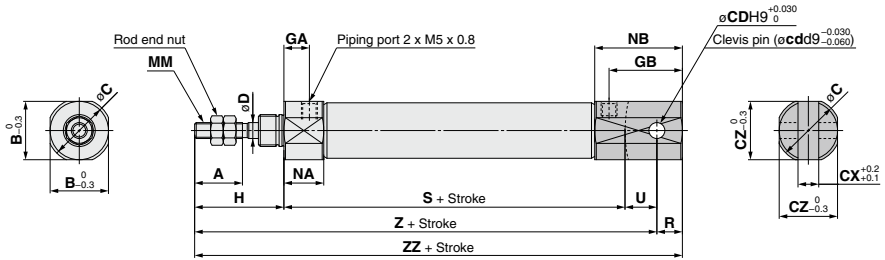

With air cushion: CJ2D Bore size – Stroke AZ

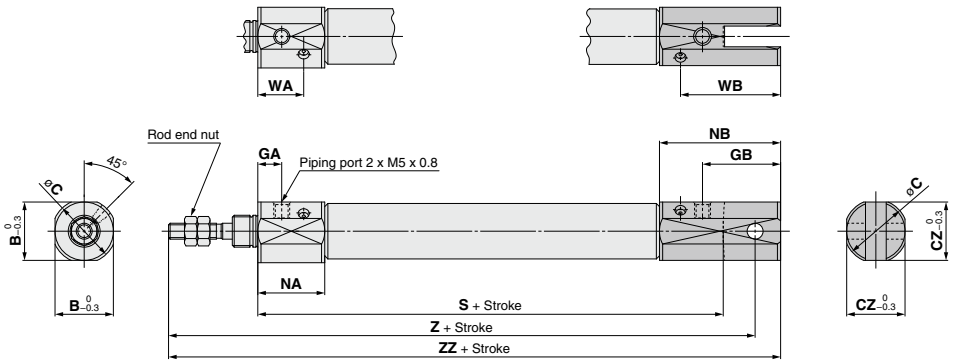

* A clevis pin and retaining rings are included.

Bore size	A	B	C	CD (cd)	CX	CZ	D	GA	GB	H	MM	NA	NB	R	S	U	Z	ZZ
10	15	12	14	3.3	3.2	12	4	8	18	28	M4 x 0.7	12.5	22.5	5	46	8	82	87
16	15	18.3	20	5	6.5	18.3	5	8	23	28	M5 x 0.8	12.5	27.5	8	47	10	85	93

With Air Cushion/Dimensions other than the table below are the same as the table above. (mm)

Bore size	B	C	CZ	GA	GB	NA	NB	WA	WB	S	Z	ZZ
10	15	17	15	7.5	19.5	21	33	14.4	26.4	65	101	106
16	18.3	20	18.3	7.5	24.5	21	38	14.4	31.4	66	104	112

Air Cylinders

CJ2

CM2

CG1

MB

CA2

CQ2

CQS

Lube-retainer

JA

MXH

MXQ

MGP

Y

X

CK1

(L)

(L) U

CKQ

CKZN

WRF

INDEX

Series CJ2

Dimensions

Double-side bossed (E)

CJ2E Bore size – Stroke Z

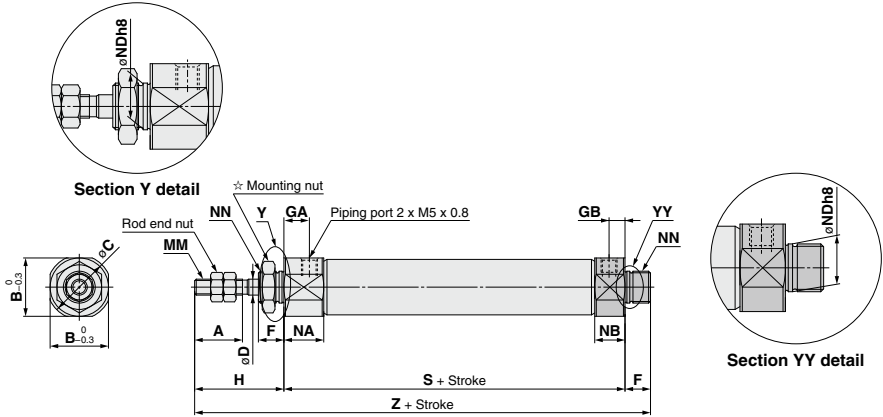

With air cushion: CJ2E Bore size – Stroke AZ

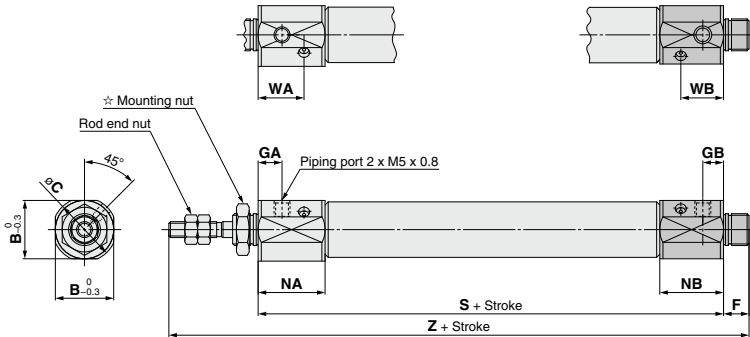

☆ For details of the mounting nut, refer to page 376.

Bore size	A	B	C	D	F	GA	GB	H	MM	NA	NB	NDh8	NN	S	Z
10	15	12	14	4	8	8	5	28	M4 x 0.7	12.5	9.5	$8_{-0.022}^0$	M8 x 1.0	46	82
16	15	18.3	20	5	8	8	5	28	M5 x 0.8	12.5	9.5	$10_{-0.022}^0$	M10 x 1.0	47	83

With Air Cushion Dimensions other than the table below are the same as the table above. (mm)

Bore size	B	C	GA	GB	NA	NB	WA	WB	S	Z
10	15	17	7.5	6.5	21	20	14.4	13.4	65	101
16	18.3	20	7.5	6.5	21	20	14.4	13.4	66	102

Series CJ2

Dimensions of Accessories (Option)

Single Knuckle Joint

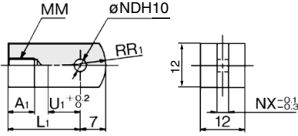

Material: Rolled steel

Part no.	Applicable bore size	A ₁	L ₁	MM	NDH10	NX	R ₁	U ₁
I-J010C	10	8	21	M4 x 0.7	3.3 ^{+0.048} _{-0.060}	3.1	8	9
I-J016C	16	8	25	M5 x 0.8	5 ^{+0.048} _{-0.060}	6.4	12	14

Double Knuckle Joint

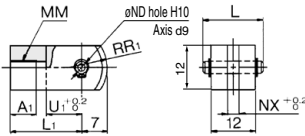

Material: Rolled steel

Part no.	Applicable bore size	A ₁	L	L ₁	MM
Y-J010C	10	8	15.2	21	M4 x 0.7
Y-J016C	16	11	16.6	21	M5 x 0.8

Part no.	NDd9	NDH10	NX	R ₁	U ₁
Y-J010C	3.3 ^{+0.030} _{-0.060}	3.3 ^{+0.048} _{-0.060}	3.2	8	10
Y-J016C	5 ^{+0.030} _{-0.060}	5 ^{+0.048} _{-0.060}	6.5	12	10

* A knuckle pin and retaining rings are included.

Clevis Pin

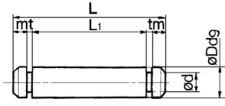

Material: Stainless steel

Part no.	Applicable bore size	Dd9	d	L	L ₁	m	t	Included retaining ring
CD-J010	10	3.3 ^{+0.030} _{-0.060}	3	15.2	12.2	1.2	0.3	Type C 3.2
CD-Z015	16	5 ^{+0.030} _{-0.060}	4.8	22.7	18.3	1.5	0.7	Type C 5
CD-JA010*	10	3.3 ^{+0.030} _{-0.060}	3	18.2	15.2	1.2	0.3	Type C 3.2

* For ø10 double clevis type, with air cushion and built-in speed controller.
* Retaining rings are included with a clevis pin.

Mounting Nut

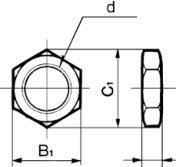

Material: Carbon steel

Part no.	Applicable bore size	B ₁	C ₁	d	H ₁
SNJ-006B	6	8	9.2	M6 x 1.0	4
SNJ-010C	10	11	12.7	M8 x 1.0	4
SNJ-016C	16	14	16.2	M10 x 1.0	4
SNKJ-016C*	16	17	19.6	M12 x 1.0	4

* For ø16 non-rotating type. (Use SNJ-016C for ø10 non-rotating type.)
* The mounting nut for ø6 is made of brass.

Knuckle Pin

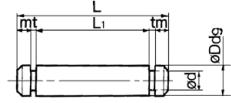

Material: Stainless steel

Part no.	Applicable bore size	Dd9	d	L	L ₁	m	t	Included retaining ring
CD-J010	10	3.3 ^{+0.030} _{-0.060}	3	15.2	12.2	1.2	0.3	Type C 3.2
IY-J015	16	5 ^{+0.030} _{-0.060}	4.8	18.6	12.2	1.5	0.7	Type C 5

* For size ø10, a clevis pin is included.
* Retaining rings are included with a knuckle pin.

Rod End Nut

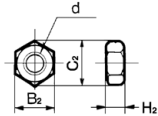

Material: Carbon steel

Part no.	Applicable bore size	B ₂	C ₂	d	H ₂
NTJ-006A	6	5.5	6.4	M3 x 0.5	2.4
NTJ-010C	10	7	8.1	M4 x 0.7	3.2
NTJ-015C	16	8	9.2	M5 x 0.8	4

T-bracket

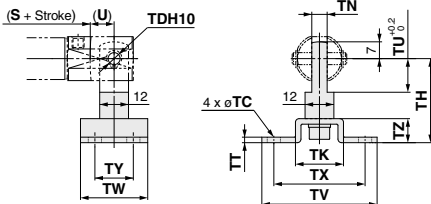

Part no.	Applicable bore size	TC	TDH10	TH	TK	TN	TT	TU	TV	TW	TX	TY	TZ
CJ-T010C	10	4.5	3.3 ^{+0.048} _{-0.060}	29	18	3.1	2	9	40	22	32	12	8
CJ-T016C	16	5.5	5 ^{+0.048} _{-0.060}	35	20	6.4	2.3	14	48	28	38	16	10

* A T-bracket includes a T-bracket base, single knuckle joint, hexagon socket head bolt and spring washer.
* For dimensions of (U) and (S + Stroke), refer to the double clevis drawing on page 374.

Rod End Cap

Flat type/CJ-CF□□□

Round type/CJ-CR□□□

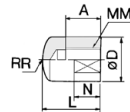
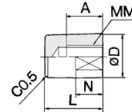

Material: Polyacetal

Part no.		Applicable bore size	A	D	L	MM	N	R	W
Flat type	Round type								
CJ-CF006	CJ-CR006	6	6	8	11	M3 x 0.5	5	8	6
CJ-CF010	CJ-CR010	10	8	10	13	M4 x 0.7	6	10	8
CJ-CF016	CJ-CR016	16	10	12	15	M5 x 0.8	7	12	10

Air Cylinders

CJ2

CM2

CG1

MB

CA2

CQ2

CQS

Lube-retainer

JA

MXH

MXQ

MGP

CY

CX

CK1

(L)□

(L)KU

CKQ

CKZN

WRF

INDEX

Air Cylinder: Standard Type Double Acting, Double Rod Series CJ2W

ø6



How to Order

Built-in Magnet Cylinder Model

Suffix the symbol "B" (Band mounting style) to the end of part number for cylinder with auto switch.

Example Band mounting CDJ2WB6-45-B

* Refer to page 459 for auto switch mounting brackets.

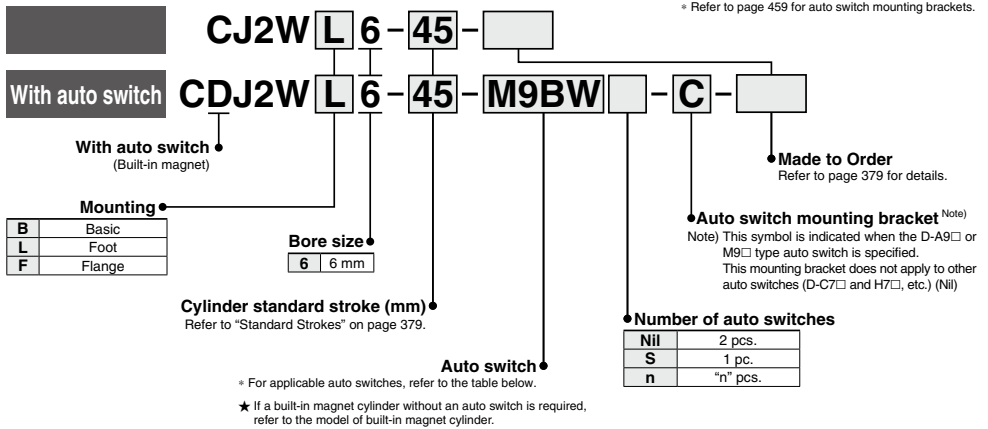

Applicable Auto Switches/Refer to the WEB catalog or the Best Pneumatics No. 2 for further information on auto switches.

Type	Special function	Electrical entry	Indicator light	Wiring (Output)	Load voltage		Auto switch model		Lead wire length (m)					Pre-wired connector	Applicable load			
					DC	AC	Perpendicular	In-line	0.5 (Nil)	1 (M)	3 (L)	5 (Z)	None (N)		IC circuit	Relay, PLC		
Solid state auto switch	—	Grommet	Yes	3-wire (NPN)	24 V	5 V, 12 V	—	M9NV	M9N	●	●	●	○	—			○	IC circuit
				3-wire (PNP)				M9PV	M9P	●	●	●	○	—	○			
		2-wire		M9BV				M9B	●	●	●	○	—	○				
		Connector		—				H7C	●	●	●	●	—	—				
	Diagnostic indication (2-color indication)	Grommet	Yes	3-wire (NPN)	24 V	5 V, 12 V	—	M9NVV	M9NW	●	●	●	○	—	○	IC circuit	Relay, PLC	
				3-wire (PNP)				M9PVV	M9PW	●	●	●	○	—	○			
	Water resistant (2-color indication)	Grommet	Yes	2-wire	24 V	12 V	—	M9BWW	M9BW	●	●	●	○	—	○	IC circuit	Relay, PLC	
				3-wire (NPN)				M9NAV****	M9NA****	○	○	●	○	—	○			
				3-wire (PNP)				M9PAV****	M9PA****	○	○	●	○	—	○			
				2-wire				M9BAV****	M9BA****	○	○	●	○	—	○			
Reed auto switch	—	Grommet	Yes	3-wire (NPN equivalent)	24 V	12 V	—	A96V	A96	●	—	●	—	—	—	IC circuit	Relay, PLC	
				—				—	—	●	—	●	—	—	—			
				2-wire				A93V	A93	●	—	●	—	—	—			
		Connector		No				100 V	A90V	A90	●	—	●	—	—	—		IC circuit
				Yes				100 V or less	—	C73C	●	—	●	—	—	—		
				No				24 V or less	—	C80C	●	—	●	—	—	—		

**** Water resistant type auto switches can be mounted on the above models, but in such case SMC cannot guarantee water resistance. Please contact SMC regarding water resistant types with the above model numbers.

* Lead wire length symbols: 0.5 m..... Nil (Example) M9NW
1 m..... M (Example) M9NWM
3 m..... L (Example) M9NWL
5 m..... Z (Example) M9NWZ
None..... N (Example) H7CN

* Since there are other applicable auto switches than listed above, refer to page 460 for details.

* For details about auto switches with pre-wired connector, refer to the WEB catalog or the Best Pneumatics No. 2.

* Solid state auto switches marked with "○" are produced upon receipt of order.

* The D-A9□□/M9□□□/A7□□ auto switches are shipped together, (but not assembled). (However, only the auto switch mounting brackets are assembled before shipment.)

Air Cylinder: Standard Type Double Acting, Double Rod

Series CJ2W

ø10, ø16



How to Order

With auto switch

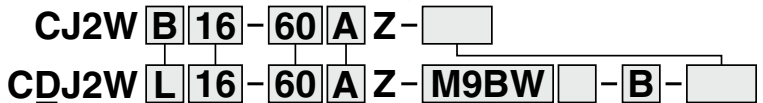

With auto switch
(Built-in magnet)

Mounting

B	Basic
L	Foot
F	Flange

* Foot/Flange brackets are shipped together with the product, but not assembled.

Bore size

10	10 mm
16	16 mm

Cylinder standard stroke (mm)

Refer to "Standard Strokes" on page 379.

Cushion

Nil	Rubber bumper
A	Air cushion

Auto switch

Nil	Without auto switch
-----	---------------------

* For applicable auto switches, refer to the table below.

Auto switch mounting type

A	Rail mounting
B	Band mounting

Number of auto switches

Nil	2 pcs.
S	1 pc.
n	"n" pcs.

* For rail mounting, screws and nuts for 2 auto switches come with the rail.

* Refer to page 459 for auto switch mounting brackets.

Made to Order

Refer to page 379 for details.

Applicable Auto Switches/Refer to the WEB catalog or the Best Pneumatics No. 2 for further information on auto switches.

Type	Special function	Electrical entry	Indicator light	Wiring (Output)	Load voltage		Auto switch model				Lead wire length (m)					Pre-wired connector	Applicable load	
					DC	AC	Band mounting		Rail mounting		0.5 (Nil)	3 (M)	3 (L)	5 (Z)	None (N)			
							Perpendicular	In-line	Perpendicular	In-line								
Solid state auto switch	—	Grommet	3-wire (NPN)	3-wire (PNP)	5 V, 12 V	—	M9NV	M9N	M9NV	M9N	●	●	●	○	○	IC circuit	Relay, PLC	
							M9PV	M9P	M9PV	M9P	●	●	●	○	○			
		Connector	2-wire	12 V	—	M9BV	M9B	M9BV	M9B	●	●	●	○	○	—			
						—	H7C	J79C	—	●	—	●	●	—	—			
	Diagnostic indication (2-color indication)	Grommet	Yes	3-wire (NPN)	3-wire (PNP)	5 V, 12 V	—	M9NWV	M9NW	M9NWV	M9NW	●	●	●	○	○		IC circuit
								M9PWV	M9PW	M9PWV	M9PW	●	●	●	○	○		—
		Connector	2-wire	12 V	—	M9BWV	M9BW	M9BWV	M9BW	●	●	●	○	○	—			
						M9NAV**	M9NA**	M9NAV**	M9NA**	○	○	○	○	○	IC circuit			
Water resistant (2-color indication)	Grommet	Yes	3-wire (NPN)	3-wire (PNP)	5 V, 12 V	—	M9PAV**	M9PA**	M9PAV**	M9PA**	○	○	○	○	○	IC circuit		
							M9BAV**	M9BA**	M9BAV**	M9BA**	○	○	○	○	○	—		
	Connector	2-wire	12 V	—	—	H7NF	A96	—	F79F	●	—	●	○	○	IC circuit			
					—	—	5 V, 12 V	—	—	—	—	—	—	—	—	—		
Reed auto switch	—	Grommet	Yes	3-wire (NPN equivalent)	5 V	—	A96V	A96	A96V	A96	●	—	—	—	—	IC circuit	Relay, PLC	
							—	200 V	—	—	A72	A72H	●	—	●	—		—
		Connector	No	2-wire	24 V	12 V	100 V or less	A93V	A93	A93V	A93	●	—	●	—	—		IC circuit
								A90V	A90	A90V	A90	●	—	●	—	—		—
	Diagnostic indication (2-color indication)	Grommet	Yes	2-wire	24 V or less	—	—	C73C	A73C	—	●	—	●	●	—	—		
							—	C80C	A80C	—	●	—	●	●	—	—		
		Connector	No	2-wire	24 V or less	—	—	—	A79C	—	—	●	—	●	●	—		—
								—	—	A79W	—	●	—	●	●	—		—

** Water resistant type auto switches can be mounted on the above models, but in such case SMC cannot guarantee water resistance. Please contact SMC regarding water resistant types with the above model numbers.

* Lead wire length symbols: 0.5 m..... Nil (Example) M9NV
 1 m..... M (Example) M9NWM
 3 m..... L (Example) M9NWL
 5 m..... Z (Example) M9NWX
 None..... N (Example) H7CN

* Since there are other applicable auto switches than listed above, refer to page 460 for details.
 * For details about auto switches with pre-wired connector, refer to the WEB catalog or the Best Pneumatics No. 2.
 * Solid state auto switches marked with "○" are produced upon receipt of order.
 * The D-A90□/M9□□/A70□/A80□/F70□/J70□ auto switches are shipped together, (but not assembled). (For band mounting, only the auto switch mounting brackets are assembled before shipment.)



Air Cylinders

CJ2

CM2

CG1

MB

CA2

CQ2

CQS

Lube-retainer

JA

MXH

MXQ

MGP

CY

CX

CK1

CLK

CLJKU

CKQ

CKZ2N

WRF

INDEX

Series CJ2W



Symbol

Double acting, Double rod, Rubber bumper

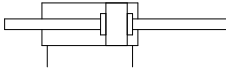

Air cushion

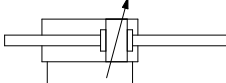

Made to Order

(For details, refer to pages 463 to 472.)

Symbol	Specifications
-XA□	Change of rod end shape
-XB6	Heat resistant cylinder (-10 to 150°C) * Not available with switch & with air cushion
-XB7	Cold resistant cylinder (-40 to 70°C) * Not available with switch & with air cushion
-XC22	Fluororubber seal * Not available with air cushion
-XC51	With hose nipple
-XC85	Grease for food processing equipment
-X446	PTFE grease

Refer to pages 453 to 460 for cylinders with auto switches.

- Auto switch proper mounting position (detection at stroke end) and its mounting height
- Minimum stroke for auto switch mounting
- Operating range
- Auto switch mounting brackets/Part no.



Precautions

Refer to page 473 before handling.

Moisture Control Tube Series IDK



When operating an actuator with a small diameter and a short stroke at a high frequency, the dew condensation (water droplet) may occur inside the piping depending on the conditions.

Simply connecting the moisture control tube to the actuator will prevent dew condensation from occurring. For details, refer to **Series IDK in the WEB catalog.**

Specifications

Bore size (mm)		6	10	16
Action		Double acting, Double rod		
Fluid		Air		
Proof pressure		1 MPa		
Maximum operating pressure		0.7 MPa		
Minimum operating pressure	Rubber bumper	0.15 MPa		0.1 MPa
	Air cushion	—		0.1 MPa
Ambient and fluid temperature		Without auto switch: -10°C to 70°C With auto switch: -10°C to 60°C (No freezing)		
Cushion		Rubber bumper	Rubber bumper/Air cushion	
Lubrication		Not required (Non-lube)		
Piston speed	Rubber bumper	50 to 750 mm/s		
	Air cushion	—	50 to 1000 mm/s	
Allowable kinetic energy	Rubber bumper	0.012 J	0.035 J	0.090 J
	Air cushion (Effective cushion length)	—	0.07 J (9.4 mm)	0.18 J (9.4 mm)
Stroke length tolerance		+1.0 0		

Standard Strokes

Bore size	Standard stroke (mm)
6	15, 30, 45, 60
10	15, 30, 45, 60, 75, 100, 125, 150
16	15, 30, 45, 60, 75, 100, 125, 150, 175, 200

* Manufacture of intermediate strokes at 1 mm intervals is possible. (Spacers are not used.)
Produced upon receipt of order.

* Please consult with SMC for strokes which exceed the standard stroke length.

* Applicable strokes should be confirmed according to the usage. For details, refer to "Air Cylinders Model Selection" on front matter pages of the Best Pneumatics No. 2 or the **WEB catalog**. In addition, the products that exceed the standard stroke might not be able to fulfill the specifications due to the deflection etc.

Mounting and Accessories

(For details, refer to page 376.)

● Mounted on the product. ○ Please order separately.

Mounting		Basic	Foot	Flange
Standard	Mounting nut	●	●	●
	Rod end nut	●	●	●
Option	Single knuckle joint	○	○	○
	Double knuckle joint*	○	○	○
	Rod end cap (Flat/Round type)	○	○	○

* A pin and retaining rings are shipped together with double knuckle joint.

Mounting Brackets/Part No.

Mounting bracket	Bore size (mm)		
	6	10	16
Foot	CJ-L006B	CJ-L010C	CJ-L016C
Flange	CJ-F006B	CJ-F010C	CJ-F016C

Weights

	Bore size (mm)	Rubber bumper			Air cushion	
		6	10	16	10	16
Basic weight (When the stroke is zero)	Basic	27	29	56	36	61
	Additional weight per 15 mm of stroke	3	4.5	7.5	4.5	7.5
Mounting bracket weight	Foot	16	16	50	16	50
	Flange	5	5	13	5	13
Accessories	Single knuckle joint	—	17	23	17	23
	Double knuckle joint (including knuckle pin)	—	25	21	25	21
	Rod end cap (Flat type)	1	1	2	1	2
	Rod end cap (Round type)	1	1	2	1	2

* Mounting nut and rod end nut are included in the basic weight.

Calculation:

Example) **CJ2WL10-45Z**

- Basic weight 29 (ø10)
 - Additional weight 4.5/15 stroke
 - Cylinder stroke 45 stroke
 - Mounting bracket weight 16 (Foot)
- 29 + 4.5/15 x 45 + 16 = **58.5 g**

Clean Series

10-CJ2W Mounting style Bore size - Stroke Z

• Clean Series

Air cylinder which is applicable for the system which discharges leakage from the rod section directly into the outside of clean room by relief port and making an actuator's rod section having a double seal construction.

For the detailed specifications, refer to the "Pneumatic Clean Series" (WEB catalog).

Specifications

Action	Double acting, Double rod
Bore size (mm)	10, 16
Maximum operating pressure	0.7 MPa
Minimum operating pressure	0.1 MPa
Cushion	Rubber bumper
Standard stroke (mm)	Same as standard type. (Refer to page 379.)
Auto switch	Mountable (Band mounting type)
Mounting	Basic, Foot, Flange

Construction (Not able to disassemble)

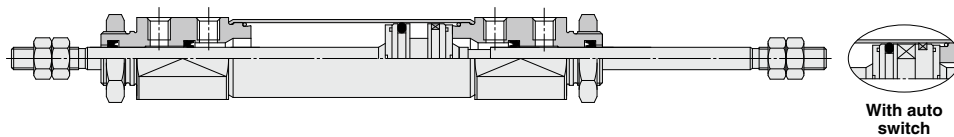

Air Cylinders

CJ2

CM2

CG1

MB

CA2

CQ2

CQS

Lube-retainer

JA

MXH

MXQ

MGP

C□Y

C□X

CK□1

C(L)□

C(L)□U

CKQ

CKZ2N

WRF

INDEX

Series CJ2W

Construction (Not able to disassemble)

CJ2W□6 Rubber bumper

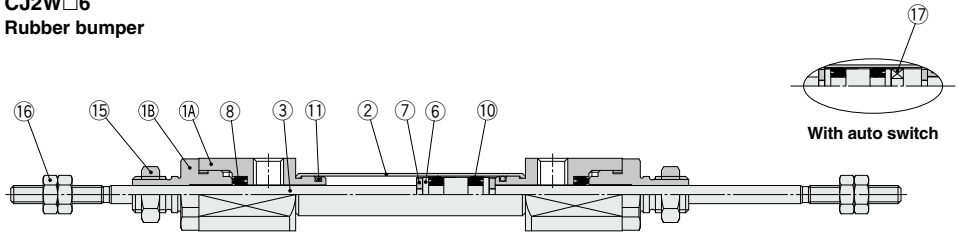

CJ2W□10, CJ2W□16 Rubber bumper

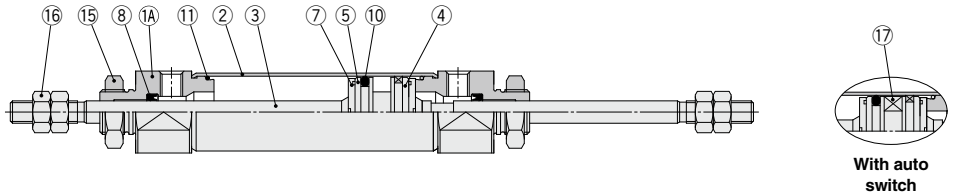

Air cushion

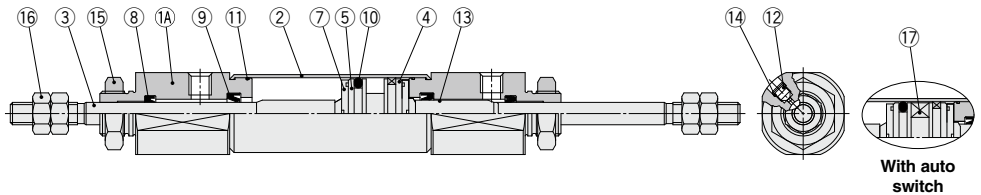

Component Parts

No.	Description	Material	Note
1A	Rod cover	Aluminum alloy	Anodized
1B	Seal retainer	Aluminum alloy	Anodized (ø6 only)
2	Cylinder tube	Stainless steel	
3	Piston rod	Stainless steel	
4	Piston A	Aluminum alloy	
5	Piston B	Aluminum alloy	
6	Piston	Brass	ø6
7	Bumper	Urethane	
8	Rod seal	NBR	

No.	Description	Material	Note
9	Cushion seal	NBR	
10	Piston seal	NBR	
11	Tube gasket	NBR	
12	Cushion needle	Carbon steel	
13	Cushion ring	Aluminum alloy	
14	Needle seal	NBR	
15	Mounting nut	Rolled steel	Zinc chromated
16	Rod end nut	Rolled steel	Zinc chromated
17	Magnet	—	

Basic (B)

CJ2WB6 – Stroke

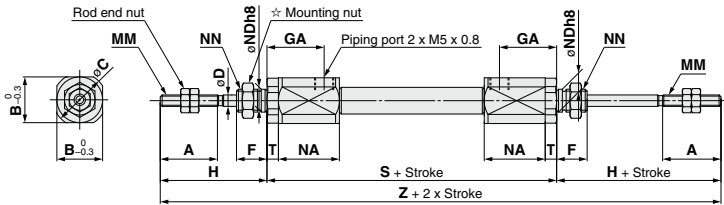

CJ2WB Bore size – Stroke Z

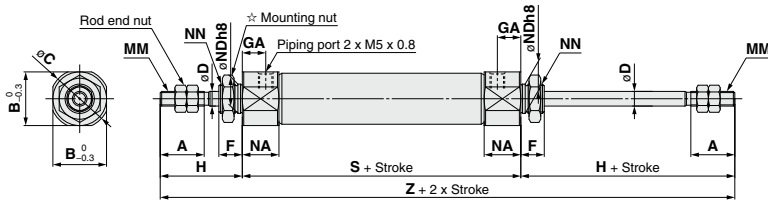

With air cushion: CJ2WB Bore size – Stroke AZ

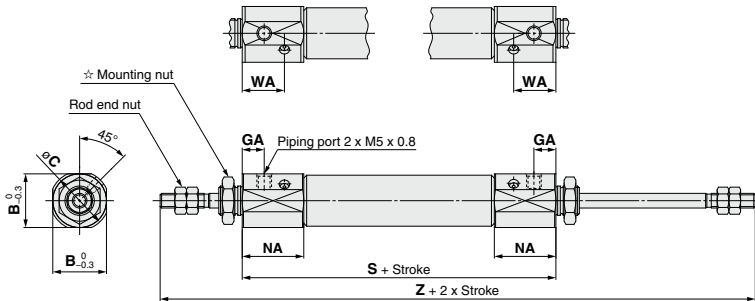

☆ For details of the mounting nut, refer to page 376.

Bore size	A	B	C	D	F	GA	H	MM	NA	NDh8	NN	S	T	Z
6	15	12	14	3	8	14.5	28	M3 x 0.5	16	6 ⁰ _{0.018}	M6 x 1.0	61 (66)	3	117 (122)
10	15	12	14	4	8	8	28	M4 x 0.7	12.5	8 ⁰ _{0.022}	M8 x 1.0	49	—	105
16	15	18.3	20	5	8	8	28	M5 x 0.8	12.5	10 ⁰ _{0.022}	M10 x 1.0	50	—	106

With Air Cushion/Dimensions other than the table below are the same as the table above.

* () in S and Z dimensions: With auto switch

Bore size	B	C	GA	NA	WA	S	Z
10	15	17	7.5	21	14.4	66	122
16	18.3	20	7.5	21	14.4	67	123

Air Cylinders

CJ2

CM2

CG1

MB

CA2

CQ2

CQS

Lube-retainer

JA

MXH

MXQ

MGP

Y

X

CK01

C(L)K□

C(L)KU

CKQ

CKZ2N

WRF

INDEX

Series CJ2W

Foot (L)

CJ2WL6 – Stroke

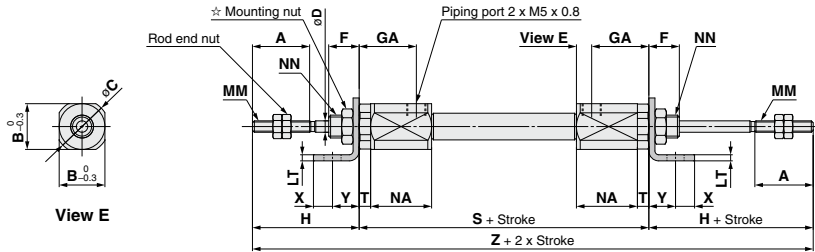

CJ2WL Bore size – Stroke Z

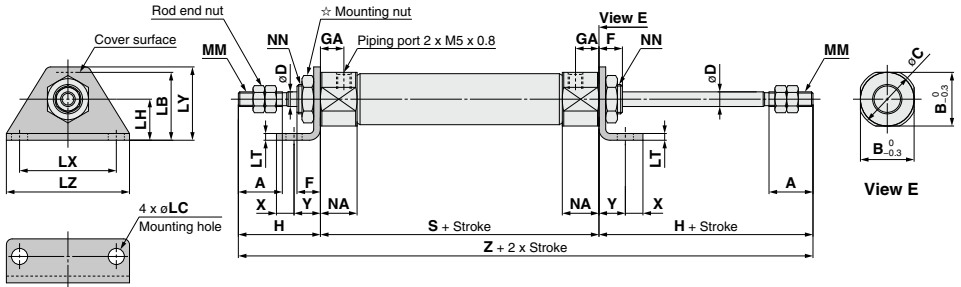

With air cushion: CJ2WL Bore size – Stroke AZ

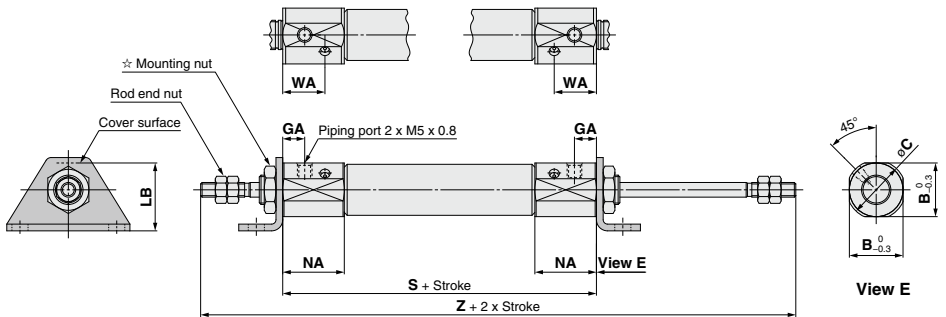

☆ For details of the mounting nut, refer to page 376.

Bore size	A	B	C	D	F	GA	H	LB	LC	LH	LT	LX	LY	LZ	MM	NA	NN	S	T	X	Y	Z
6	15	12	14	3	8	14.5	28	15	4.5	9	1.6	24	16.5	32	M3 x 0.5	16	M6 x 1.0	61 (66)	3	5	7	117 (122)
10	15	12	14	4	8	8	28	15	4.5	9	1.6	24	16.5	32	M4 x 0.7	12.5	M8 x 1.0	49	—	5	7	105
16	15	18.3	20	5	8	8	28	23	5.5	14	2.3	33	25	42	M5 x 0.8	12.5	M10 x 1.0	50	—	6	9	106

With Air Cushion Dimensions other than the table below are the same as the table above.

Bore size	B	C	GA	LB	NA	S	Z
10	15	17	7.5	16.5	21	14.4	66
16	18.3	20	7.5	23	21	14.4	67

* () in S and Z dimensions: With auto switch

Flange (F)

CJ2WF6 – Stroke

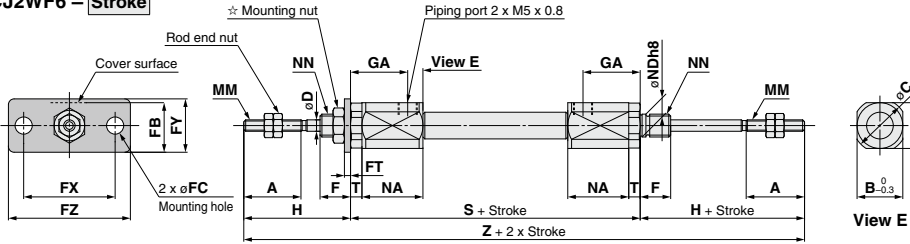

CJ2WF Bore size – Stroke Z

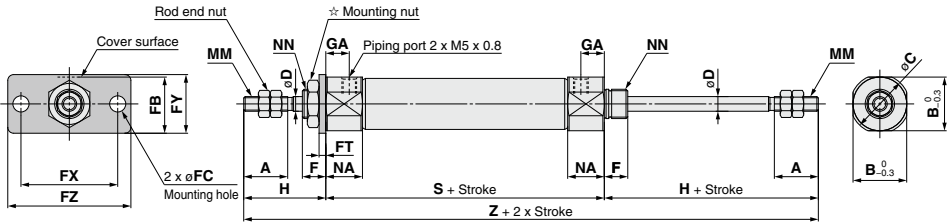

With air cushion: CJ2WF Bore size – Stroke AZ

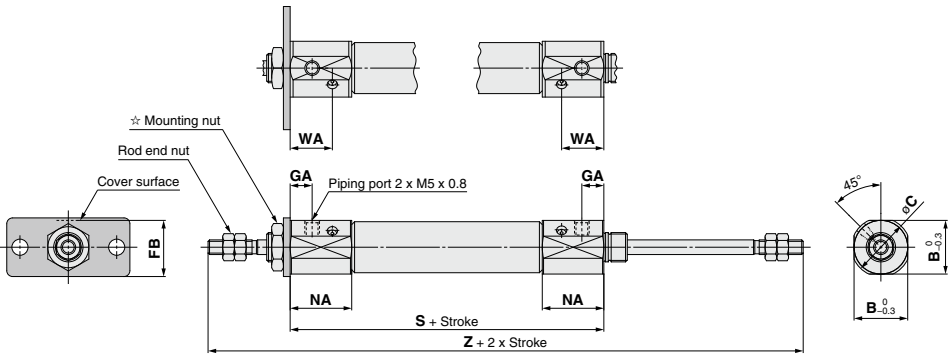

☆ For details of the mounting nut, refer to page 376.

Bore size	A	B	C	D	F	FB	FC	FT	FX	FY	FZ	GA	H	MM	NA	NN	S	T	Z
6	15	12	14	3	8	13	4.5	1.6	24	14	32	14.5	28	M3 x 0.5	16	M6 x 1.0	61 (66)	3	117 (122)
10	15	12	14	4	8	13	4.5	1.6	24	14	32	8	28	M4 x 0.7	12.5	M8 x 1.0	49	—	105
16	15	18.3	20	5	8	19	5.5	2.3	33	20	42	8	28	M5 x 0.8	12.5	M10 x 1.0	50	—	106

With Air Cushion Dimensions other than the table below are the same as the table above.

Bore size	B	C	GA	FB	NA	WA	S	Z
10	15	17	7.5	14.5	21	14.4	66	122
16	18.3	20	7.5	19	21	14.4	67	123

* () in S and Z dimensions: With auto switch

Air Cylinders

CJ2

CM2

CG1

MB

CA2

CQ2

CQS

Lube-retainer

JA

MXH

MXQ

MGP

Y

X

CK□1

□(L)□

□(L)□U

CKQ

CKZ2N

WRF

INDEX

Air Cylinder: Standard Type Single Acting, Spring Return/Extend

Series CJ2

ø6



How to Order

Built-in Magnet Cylinder Model

Suffix the symbol "B" (Band mounting style) to the end of part number for cylinder with auto switch.

Example Band mounting CDJ2B6-45S-B

* Refer to page 459 for auto switch mounting brackets.

Cylinder standard stroke (mm)
Refer to "Standard Strokes" on page 387.

Action
S Single acting, Spring return
T Single acting, Spring extend

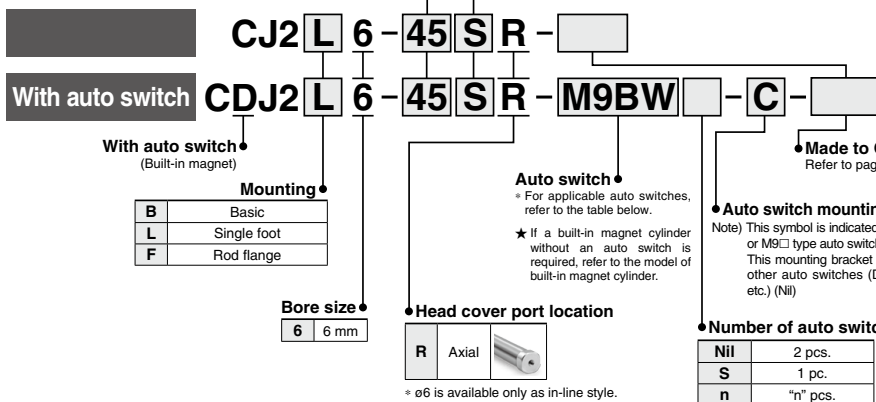

Applicable Auto Switches/Refer to the WEB catalog or the Best Pneumatics No. 2 for further information on auto switches.

Type	Special function	Electrical entry	Indicator/light	Wiring (Output)	Load voltage		Auto switch model		Lead wire length (m)					Pre-wired connector	Applicable load		
					DC	AC	Perpendicular	In-line	0.5 (Nil)	1 (M)	3 (L)	5 (Z)	None (N)				
Solid state auto switch	—	Grommet	—	3-wire (NPN)	5 V, 12 V	—	M9NV	M9N	●	●	●	○	—	○	IC circuit	Relay, PLC	
				3-wire (PNP)			M9PV	M9P	●	●	●	○	—				
		Connector	2-wire	12 V	M9BV	M9B	●	●	●	○	—						
	Diagnostic indication (2-color indication)	Grommet	Yes	3-wire (NPN)	5 V, 12 V	24 V	M9NVV	M9NW	●	●	●	○	—	○			
				3-wire (PNP)			M9PVV	M9PW	●	●	●	○	—				
		Connector	2-wire	12 V	M9BWW	M9BW	●	●	●	○	—						
	Water resistant (2-color indication)	Grommet	—	3-wire (NPN)	5 V, 12 V	—	M9NAV**	M9NA**	○	○	●	○	—	○			
				3-wire (PNP)			M9PAV**	M9PA**	○	○	●	○	—				
		Connector	2-wire	12 V	M9BAV**	M9BA**	○	○	●	○	—						
	With diagnostic output (2-color indication)	—	Grommet	Yes	4-wire (NPN)	5 V, 12 V	—	—	H7NF	●	—	●	○	—			○
Reed auto switch					—			Grommet	Yes	3-wire (NPN equivalent)	A96V	A96	●	—	●	—	—
										2-wire	—	—	—	—	●	—	—
—	—	Grommet	No	2-wire	24 V	12 V	—	A93V	A93	●	—	●	—	—			
							100 V or less	A90V	A90	●	—	●	—	—			
		Connector	Yes	—	—	24 V or less	—	C73C	—	—	●	●	—	—			
				No	—	—	—	—	C80C	●	—	●	●	—	—		

** Water resistant type auto switches can be mounted on the above models, but in such case SMC cannot guarantee water resistance. Please contact SMC regarding water resistant types with the above model numbers.

* Lead wire length symbols: 0.5 m..... Nil (Example) M9NW
 1 m..... M (Example) M9NWM
 3 m..... L (Example) M9NLW
 5 m..... Z (Example) M9NZW
 None..... N (Example) H7CN

* Since there are other applicable auto switches than listed, refer to page 460 for details.
 * For details about auto switches with pre-wired connector, refer to the WEB catalog or the Best Pneumatics No. 2.

* Solid state auto switches marked with "○" are produced upon receipt of order.

* The D-A9□□/M9□□□ auto switches are shipped together, (but not assembled). (However, only auto switch mounting brackets are assembled before being shipped.)

Series CJ2

Spring extend



Spring return

Symbol

Single acting, Spring return,
Rubber bumper

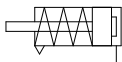

Single acting, Spring extend,
Rubber bumper

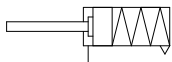

Made to Order

(For details, refer to pages 463 to 472.)

Symbol	Specifications
-XA□	Change of rod end shape
-XC22	Fluororubber seal
-XC51	With hose nipple
-XC85	Grease for food processing equipment
-X446	PTFE grease
-X773*	Short pitch mounting/Single acting, spring return

* e6 only

Refer to pages 453 to 460 for cylinders with auto switches.

- Auto switch proper mounting position (detection at stroke end) and its mounting height
- Minimum stroke for auto switch mounting
- Operating range
- Auto switch mounting brackets/Part no.

⚠ Precautions

Refer to page 473 before handling.

Ordering Example of Cylinder Assembly

Cylinder model: CDJ2D16-45SZ-NW-M9BW-B

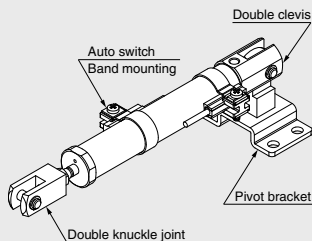

Mounting D: Double clevis
Pivot bracket N: Yes
Rod end bracket W: Double knuckle joint
Auto switch D-M9BW: 2 pcs.
Auto switch mounting B: Band mounting

* Pivot bracket, double knuckle joint and auto switch are shipped together with the product, but not assembled.

Specifications

Bore size (mm)		6	10	16
Action		Single acting, Spring return/Single acting, Spring extend		
Fluid		Air		
Proof pressure		1 MPa		
Maximum operating pressure		0.7 MPa		
Minimum operating pressure	Spring return	0.2 MPa	0.15 MPa	
	Spring extend	0.25 MPa	0.15 MPa	
Ambient and fluid temperature		Without auto switch: -10°C to 70°C With auto switch: -10°C to 60°C (No freezing)		
Cushion		Rubber bumper		
Lubrication		Not required (Non-lube)		
Stroke length tolerance		+1.0 0		
Piston speed		50 to 750 mm/s		
Allowable kinetic energy		0.012 J	0.035 J	0.090 J

Standard Strokes

Bore size	Standard stroke (mm)
6	15, 30, 45, 60
10	15, 30, 45, 60
16	15, 30, 45, 60, 75, 100, 125, 150

- * Manufacture of intermediate strokes at 1 mm intervals is possible. (Spacers are not used.)
- * Please select with SMC for strokes which exceed the standard stroke length.
- * Applicable strokes should be confirmed according to the usage. For details, refer to "Air Cylinders Model Selection" on front matter pages of the Best Pneumatics No. 2 or the WEB catalog. In addition, the products that exceed the standard stroke might not be able to fulfill the specifications due to the deflection etc.

Spring Reaction Force

Bore size (mm)	Spring reaction force (N)	
	Primary	Secondary
6	1.77	3.72
10	3.53	6.86
16	6.86	14.2

Spring with primary mounting load

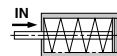

When the spring is set in the cylinder

Spring with secondary mounting load

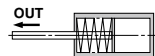

When the spring is contracted by applying air

Mounting Brackets/Part No.

Mounting bracket	Bore size (mm)		
	6	10	16
Foot	CJ-L006B	CJ-L010C	CJ-L016C
Flange	CJ-F006B	CJ-F010C	CJ-F016C
T-bracket*	—	CJ-T010C	CJ-T016C

* T-bracket is used with double clevis (D).

Theoretical Output

Refer to the "Single acting, Spring return cylinder" in Theoretical Output 1 of Technical data 3 in Best Pneumatics No. 2. In the case of the spring extend type, the force at OUT side will be the ending force of the spring return, and that at the IN side will be the amount of the IN side force of the double acting type cylinder from which the beginning force of the spring return has been subtracted.

Moisture Control Tube Series IDK

When operating an actuator with a small diameter and a short stroke at a high frequency, the dew condensation (water droplet) may occur inside the piping depending on the conditions.

Simply connecting the moisture control tube to the actuator will prevent dew condensation from occurring. For details, refer to **Series IDK in the WEB catalog**.

Mounting and Accessories /For details, refer to page 376.

● --- Mounted on the product. ○ --- Can be ordered within the cylinder model.

Mounting		Basic	Foot	Flange	Double* clevis	Double clevis (including T-bracket)
Standard	Mounting nut	●	●	●	—	—
	Rod end nut	●	●	●	●	●
	Clevis pin	—	—	—	●	●
Option	Single knuckle joint	○	○	○	○	○
	Double knuckle joint*	○	○	○	○	○
	Rod end cap (Flat/Round type)	○	○	○	○	○
	T-bracket	—	—	—	○	●

* A pin and retaining rings are shipped together with double clevis and double knuckle joint.

Weights

Spring Return (g)

Bore size (mm)		6					10					16									
Mounting		Basic	Basic	Axial piping	Double clevis (including clevis pin)	Head-side bossed	Basic	Basic	Axial piping	Double clevis (including clevis pin)	Head-side bossed	Basic	Basic	Axial piping	Double clevis (including clevis pin)	Head-side bossed					
Basic weight	15 stroke	11	28	28	29	28	62	62	69	64											
	30 stroke	16	35	35	35	35	77	77	84	79											
	45 stroke	18	44	44	45	45	95	95	102	97											
	60 stroke	23	54	54	55	54	113	113	119	115											
	75 stroke	/					134	134	141	136											
	100 stroke						167	167	174	169											
	125 stroke						204	204	212	206											
150 stroke	227						227	234	229												
Mounting bracket weight	Single foot	8	8					25													
	Double foot	—	16					50													
	Rod flange	5	5					13													
	Head flange	—	5					13													
Accessories	Single knuckle joint	—	17					23													
	Double knuckle joint (including knuckle pin)	—	25					21													
	Rod end cap (Flat type)	1	1					2													
	Rod end cap (Round type)	1	1					2													
	T-bracket	—	32					50													

* Mounting nut and rod end nut are included in the basic weight.

Note) Mounting nut is not attached to the double clevis, so the mounting nut weight is already subtracted.

Calculation:

Example) **CJ2L10-45SZ**

● Basic weight 44 (ø10-45 stroke)

● Mounting bracket weight..... 8 (Single foot)

44 + 8 = 52 g

Spring Extend (g)

Bore size (mm)		6					10					16									
Mounting		Basic	Basic	Axial piping	Double clevis (including clevis pin)	Head-side bossed	Basic	Basic	Axial piping	Double clevis (including clevis pin)	Head-side bossed	Basic	Basic	Axial piping	Double clevis (including clevis pin)	Head-side bossed					
Basic weight	15 stroke	17	28	28	30	29	63	63	71	67											
	30 stroke	21	34	34	36	35	77	77	85	80											
	45 stroke	23	42	42	44	43	93	93	100	96											
	60 stroke	27	51	51	52	51	109	109	116	112											
	75 stroke	/					129	129	137	133											
	100 stroke						159	159	166	162											
	125 stroke						193	193	201	196											
150 stroke	213						213	221	217												
Mounting bracket weight	Single foot	8	8					25													
	Double foot	—	16					50													
	Rod flange	5	5					13													
	Head flange	—	5					13													
Accessories	Single knuckle joint	—	17					23													
	Double knuckle joint (including knuckle pin)	—	25					21													
	Rod end cap (Flat type)	1	1					2													
	Rod end cap (Round type)	1	1					2													
	T-bracket	—	32					50													

* Mounting nut and rod end nut are included in the basic weight.

Note) Mounting nut is not attached to the double clevis, so the mounting nut weight is already subtracted.

Calculation:

Example) **CJ2L10-45TZ**

● Basic weight 42 (ø10-45 stroke)

● Mounting bracket weight..... 8 (Single foot)

42 + 8 = 50 g

Air Cylinders

CJ2

CM2

CG1

MB

CA2

CQ2

CQS

Lube-retainer

JA

MXH

MXQ

MGP

C□Y

C□X

CK□1

C(L)□

C(L)KU

CKQ

CKZ2N

WRF

INDEX

Series CJ2

Construction (Not able to disassemble)

Single acting, Spring return

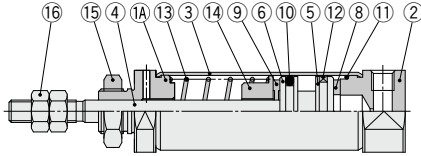

CJ2□6 Piston/Head cover

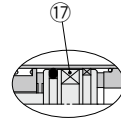
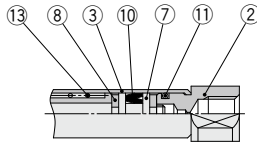

CDJ2B10/16-□SZ-B

Single acting, Spring extend

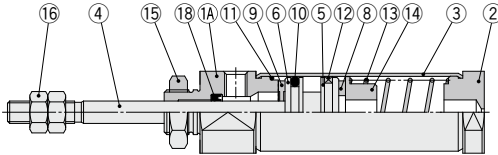

CJ2□6 Piston/Rod cover

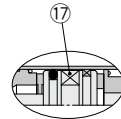
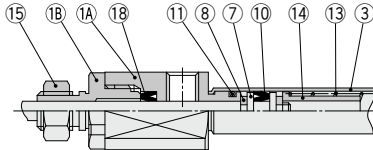

CDJ2B10/16-□TZ-B

Component Parts

No.	Description	Material	Note
1A	Rod cover	Aluminum alloy	Clear hard anodized
1B	Seal retainer	Aluminum alloy	Anodized (ø6 only)
2	Head cover	Aluminum alloy	Clear hard anodized
3	Cylinder tube	Stainless steel	
4	Piston rod	Stainless steel	
5	Piston A	Aluminum alloy	ø10, ø16
6	Piston B	Aluminum alloy	ø10, ø16
7	Piston	Brass	ø6
8	Bumper A	Urethane	
9	Bumper B	Urethane	

No.	Description	Material	Note
10	Piston seal	NBR	
11	Tube gasket	NBR	
12	Wear ring	Resin	
13	Return spring	Piano wire	Zinc chromated
14	Spring seat	Aluminum alloy	
15	Mounting nut	Rolled steel	Zinc chromated
16	Rod end nut	Rolled steel	Zinc chromated
17	Magnet	—	
18	Rod seal	NBR	

* The spring seat for ø6 is made of brass.

Series CJ2

Single Acting, Spring Return: Double Clevis (D)

CJ2D Bore size – Stroke SZ

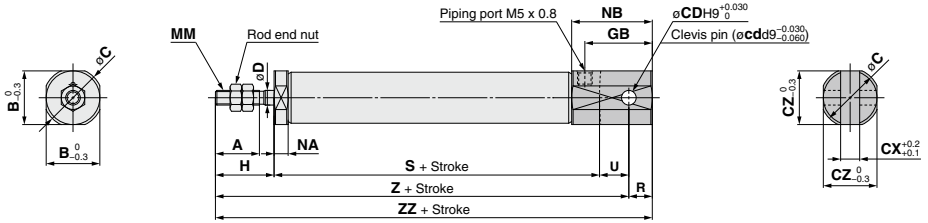

(mm)

Bore size	A	B	C	CD (cd)	CX	CZ	D	GB	H	MM	NA	NB	R	U	S							
															5 to 15 st	16 to 30 st	31 to 45 st	46 to 60 st	61 to 75 st	76 to 100 st	101 to 125 st	126 to 150 st
10	15	12	14	3.3	3.2	12	4	18	20	M4 x 0.7	4.8	22.5	5	8	45.5	53	65	77	84	108	126	138
16	15	18.3	20	5	6.5	18.3	5	23	20	M5 x 0.8	4.8	27.5	8	10	45.5	54	66	78	84	108	126	138

Bore size	Z								ZZ							
	5 to 15 st	16 to 30 st	31 to 45 st	46 to 60 st	61 to 75 st	76 to 100 st	101 to 125 st	126 to 150 st	5 to 15 st	16 to 30 st	31 to 45 st	46 to 60 st	61 to 75 st	76 to 100 st	101 to 125 st	126 to 150 st
10	73.5	81	93	105	—	—	—	—	78.5	86	98	110	—	—	—	—
16	75.5	84	96	108	114	138	156	168	83.5	92	104	116	122	146	164	176

* A clevis pin and retaining rings are included.

Single Acting, Spring Return: Single Foot (L)

CJ2L6 – Stroke SR

CJ2L Bore size – Stroke S Head cover port location Z

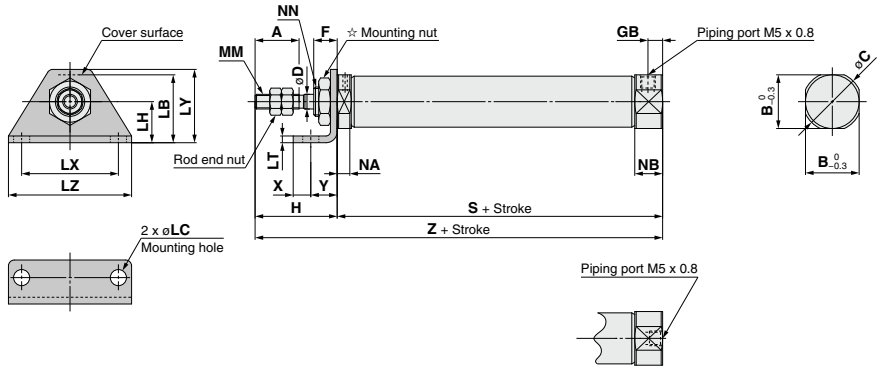

Head cover port location
Axial location (R)

* The overall cylinder length does not change.

☆ For details of the mounting nut, refer to page 376.

(mm)

Bore size	A	B	C	D	F	GB	H	LB	LC	LH	LT	LX	LY	LZ	MM	NA	NB	NN	S								X	Y	Z																																																																																																							
																			5 to 15 st	16 to 30 st	31 to 45 st	46 to 60 st	61 to 75 st	76 to 100 st	101 to 125 st	126 to 150 st			5 to 15 st	16 to 30 st	31 to 45 st	46 to 60 st	61 to 75 st	76 to 100 st	101 to 125 st	126 to 150 st																																																																																																
6	15	8	9	3	8	—	28	13	4.5	9	1.6	24	16.5	32	M3 x 0.5	3	7	M6 x 1.0	34.5 (39.5)	43.5 (48.5)	47.5 (52.5)	61.5 (66.5)	—	—	—	—	—	—	5	7	62.5 (67.5)	71.5 (76.5)	75.5 (80.5)	89.5 (94.5)	—	—	—	—	—	—	—	—																																																																																										
10	15	12	14	4	8	5	28	15	4.5	9	1.6	24	16.5	32	M4 x 0.7	4.8	9.5	M8 x 1.0	45.5 (49.5)	53 (57.5)	65 (69.5)	77 (81.5)	—	—	—	—	—	—	5	7	73.5 (77.5)	81 (85.5)	93 (97.5)	105 (109.5)	—	—	—	—	—	—	—	—	—	—																																																																																								
16	15	18.3	20	5	8	5	28	23	5.5	14	2.3	33	25	42	M5 x 0.8	4.8	9.5	M10 x 1.0	45.5 (49.5)	54 (58.5)	66 (70.5)	78 (82.5)	84 (88.5)	108 (112.5)	126 (130.5)	138 (142.5)	146 (150.5)	164 (168.5)	176 (180.5)	184 (188.5)	192 (196.5)	200 (204.5)	208 (212.5)	216 (220.5)	224 (228.5)	232 (236.5)	240 (244.5)	248 (252.5)	256 (260.5)	264 (268.5)	272 (276.5)	280 (284.5)	288 (292.5)	296 (300.5)	304 (308.5)	312 (316.5)	320 (324.5)	328 (332.5)	336 (340.5)	344 (348.5)	352 (356.5)	360 (364.5)	368 (372.5)	376 (380.5)	384 (388.5)	392 (396.5)	400 (404.5)	408 (412.5)	416 (420.5)	424 (428.5)	432 (436.5)	440 (444.5)	448 (452.5)	456 (460.5)	464 (468.5)	472 (476.5)	480 (484.5)	488 (492.5)	496 (500.5)	504 (508.5)	512 (516.5)	520 (524.5)	528 (532.5)	536 (540.5)	544 (548.5)	552 (556.5)	560 (564.5)	568 (572.5)	576 (580.5)	584 (588.5)	592 (596.5)	600 (604.5)	608 (612.5)	616 (620.5)	624 (628.5)	632 (636.5)	640 (644.5)	648 (652.5)	656 (660.5)	664 (668.5)	672 (676.5)	680 (684.5)	688 (692.5)	696 (700.5)	704 (708.5)	712 (716.5)	720 (724.5)	728 (732.5)	736 (740.5)	744 (748.5)	752 (756.5)	760 (764.5)	768 (772.5)	776 (780.5)	784 (788.5)	792 (796.5)	800 (804.5)	808 (812.5)	816 (820.5)	824 (828.5)	832 (836.5)	840 (844.5)	848 (852.5)	856 (860.5)	864 (868.5)	872 (876.5)	880 (884.5)	888 (892.5)	896 (900.5)	904 (908.5)	912 (916.5)	920 (924.5)	928 (932.5)	936 (940.5)	944 (948.5)	952 (956.5)	960 (964.5)	968 (972.5)	976 (980.5)	984 (988.5)	992 (996.5)	1000 (1004.5)

* () in S and Z dimensions: With auto switch

Single Acting, Spring Extend: Single Foot (L)

CJ2L6 – Stroke T

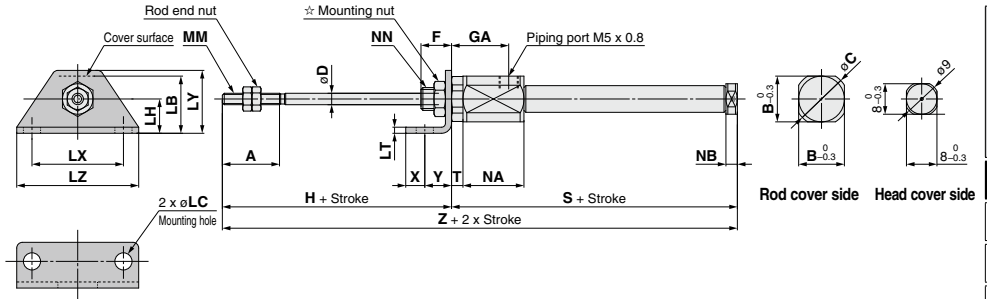

CJ2L Bore size – Stroke TZ

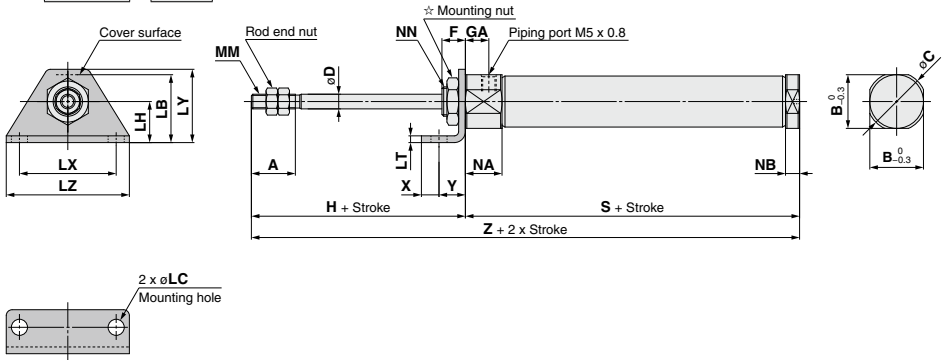

☆ For details of the mounting nut, refer to page 376.

Bore size																S				Z																	
	A	B	C	D	F	GA	H	LB	LC	LH	LT	LX	LZ	MM	NA	NB	NN	T	X	Y	5 to 15 st	16 to 30 st	31 to 45 st	46 to 60 st	61 to 75 st	76 to 100 st	101 to 125 st	126 to 150 st	5 to 15 st	16 to 30 st	31 to 45 st	46 to 60 st	61 to 75 st	76 to 100 st	101 to 125 st	126 to 150 st	
6	15	12	14	3	8	14.5	28	15	4.5	9	1.6	24	16.5	32	M3 x 0.5	16	3	M6 x 1.0	3	46.5	55.5	59.5	73.5	—	—	—	—	5	7	74.5	83.5	87.5	101.5	—	—	—	—
10	15	12	14	4	8	8	28	15	4.5	9	1.6	24	16.5	32	M4 x 0.7	12.5	4.8	M8 x 1.0	—	48.5	56	68	80	—	—	—	—	5	7	76.5	84	96	108	—	—	—	—
16	15	18.3	20	5	8	8	28	23	5.5	14	2.3	33	25	42	M5 x 0.8	12.5	4.8	M10 x 1.0	—	48.5	57	69	81	87	111	129	141	6	9	76.5	85	97	109	115	139	157	169

* () in S and Z dimensions: With auto switch

Air Cylinders

- CJ2**
- CM2**
- CG1**
- MB**
- CA2**
- CQ2**
- CQS**
- Lube-retainer
- JA**
- MXH**
- MXQ**
- MGP**
- C□Y**
- C□X**
- CK□1**
- C(L)□**
- C(L)□U**
- CKQ**
- CKZ2N**
- WRF**

Single Acting, Spring Extend: Rod Flange (F)

CJ2F6 – Stroke T

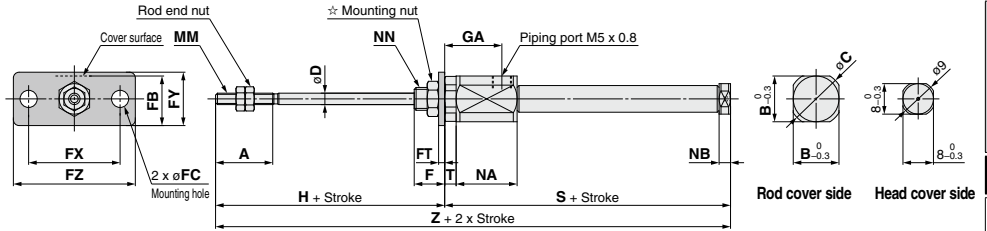

CJ2F Bore size – Stroke TZ

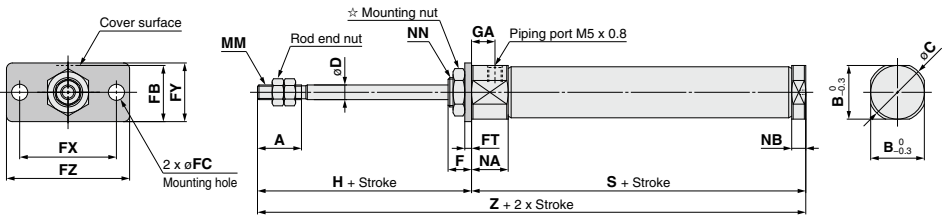

☆ For details of the mounting nut, refer to page 376.

Bore size														S												Z											
	A	B	C	D	F	FB	FC	FT	FX	FY	FZ	GA	H	MM	NA	NB	NN	T	5 to 15 st	16 to 30 st	31 to 45 st	46 to 60 st	61 to 75 st	76 to 100 st	101 to 125 st	126 to 150 st	5 to 15 st	16 to 30 st	31 to 45 st	46 to 60 st	61 to 75 st	76 to 100 st	101 to 125 st	126 to 150 st			
6	15	12	14	3	8	13	4.5	1.6	24	14	32	145	28	M3 x 0.5	16	3	M6 x 1.0	3	46.5	55.5	59.5	73.5	—	—	—	—	74.5	83.5	87.5	101.5	—	—	—	—			
10	15	12	14	4	8	13	4.5	1.6	24	14	32	8	28	M4 x 0.7	12.5	4.8	M8 x 1.0	—	48.5	56	68	80	—	—	—	—	76.5	84	96	108	—	—	—	—			
16	15	18.3	20	5	8	19	5.5	2.3	33	20	42	8	28	M5 x 0.8	12.5	4.8	M10 x 1.0	—	48.5	57	69	81	87	111	129	141	76.5	85	97	109	115	139	157	169			

* () in S and Z dimensions: With auto switch

- Air Cylinders
- CJ2**
- CM2
- CG1
- MB
- CA2
- CQ2
- CQS
- Lube-retainer
- JA
- MXH
- MXQ
- MGP
- CY
- CX
- CK□1
- C(L)K□
- C(L)KU
- CKQ
- CKZN
- WRF

Air Cylinder: Non-rotating Rod Type Double Acting, Single Rod **Series CJ2K**

A cylinder which rod does not rotate because of the hexagonal rod shape.

Non-rotating accuracy
 $\phi 10: \pm 1.5^\circ$, $\phi 16: \pm 1^\circ$
Can operate without lubrication.



Symbol

Double acting, Single rod, Rubber bumper



Made to Order

(For details, refer to pages 463 to 472.)

Symbol	Specifications
-XA□	Change of rod end shape
-XC3	Special port location
-XC9	Adjustable stroke cylinder/Adjustable retraction type
-XC10	Dual stroke cylinder/Double rod type
-XC22	Fluororubber seal
-XC51	With hose nipple
-XC85	Grease for food processing equipment
-X446	PTFE grease

⚠ Precautions

Refer to page 473 before handling.

Ordering Example of Cylinder Assembly

Cylinder model: **CDJ2KD16-60Z-NW-M9BW-B**

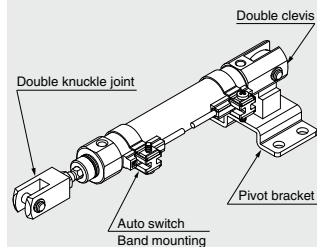

Mounting D: Double clevis
Pivot bracket N: Yes
Rod end bracket W: Double knuckle joint
Auto switch D-M9BW: 2 pcs.
Auto switch mounting B: Band mounting

* Pivot bracket, double knuckle joint and auto switch are shipped together with the product, but not assembled.

Specifications

Bore size (mm)	10	16
Action	Double acting, Single rod	
Fluid	Air	
Proof pressure	1 MPa	
Maximum operating pressure	0.7 MPa	
Minimum operating pressure	0.06 MPa	
Ambient and fluid temperature	Without auto switch: -10°C to 70°C With auto switch: -10°C to 60°C (No freezing)	
Cushion	Rubber bumper	
Lubrication	Not required (Non-lube)	
Stroke length tolerance	$^{+1.0}$ 0	
Rod non-rotating accuracy	$\pm 1.5^\circ$	$\pm 1^\circ$
Piston speed	50 to 750 mm/s	
Allowable kinetic energy	0.035 J	0.090 J

Standard Strokes

Bore size (mm)	Standard stroke (mm)
10	15, 30, 45, 60, 75, 100, 125, 150
16	15, 30, 45, 60, 75, 100, 125, 150, 175, 200

* Manufacture of intermediate strokes at 1 mm intervals is possible. (Spacers are not used.)

* Please consult with SMC for strokes which exceed the standard stroke length.

* Applicable strokes should be confirmed according to the usage. For details, refer to "Air Cylinders Model Selection" on front matter pages of the Best Pneumatics No. 2 or the **WEB catalog**. In addition, the products that exceed the standard stroke might not be able to fulfill the specifications due to the deflection etc.

Mounting and Accessories /For details, refer to page 376.

●···Mounted on the product. ○···Can be ordered within the cylinder model.

Mounting		Basic	Foot	Flange	Double* clevis	Double clevis (including T-bracket)
Standard	Mounting nut	●	●	●	—	—
	Rod end nut	●	●	●	●	●
	Clevis pin	—	—	—	●	●
Option	Single knuckle joint	○	○	○	○	○
	Double knuckle joint*	○	○	○	○	○
	Rod end cap (Flat/Round type)	○	○	○	○	○
	T-bracket	—	—	—	○	●

* A pin and retaining rings are shipped together with double clevis and double knuckle joint.

Mounting Brackets/Part No.

Mounting bracket	Bore size (mm)	
	10	16
Foot	CJ-L016C	CJK-L016C
Flange	CJ-F016C	CJK-F016C
T-bracket*	CJ-T010C	CJ-T016C

* T-bracket is used with double clevis (D).

Refer to pages 453 to 460 for cylinders with auto switches.

- Auto switch proper mounting position (detection at stroke end) and its mounting height
- Minimum stroke for auto switch mounting
- Operating range
- Auto switch mounting brackets/Part no.

Series CJ2K

Weights

		(g)	
Bore size (mm)		10	16
Basic weight (When the stroke is zero)	Basic	25	47
	Axial piping	25	47
	Double clevis (including clevis pin)	27	55
	Head-side bossed	29	50
Additional weight per 15 mm of stroke		4	7
Mounting bracket weight	Single foot	8	25
	Double foot	16	50
	Rod flange	5	13
	Head flange	5	13
Accessories	Single knuckle joint	17	23
	Double knuckle joint (including knuckle pin)	25	21
	Rod end cap (Flat type)	1	2
	Rod end cap (Round type)	1	2
	T-bracket	32	50

* Mounting nut and rod end nut are included in the basic weight.

(Note) Mounting nut is not included in the basic weight for the double clevis.

Calculation:

Example) **CJ2KL10-45Z**

- Basic weight25 (ø10)
- Additional weight4/15 stroke
- Cylinder stroke45 stroke
- Mounting bracket weight ...8 (Single foot)

$$25 + 4/15 \times 45 + 8 = 45 \text{ g}$$

Construction (Not able to disassemble)

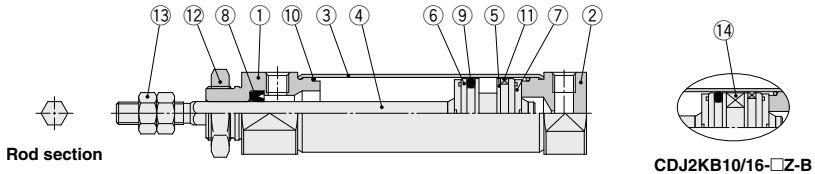

Component Parts

No.	Description	Material	Note
1	Rod cover	Aluminum alloy	Clear hard anodized
2	Head cover	Aluminum alloy	Clear hard anodized
3	Cylinder tube	Stainless steel	
4	Piston rod	Stainless steel	
5	Piston A	Aluminum alloy	
6	Piston B	Aluminum alloy	
7	Bumper	Urethane	

No.	Description	Material	Note
8	Rod seal	NBR	
9	Piston seal	NBR	
10	Tube gasket	NBR	
11	Wear ring	Resin	
12	Mounting nut	Rolled steel	Zinc chromated
13	Rod end nut	Rolled steel	Zinc chromated
14	Magnet	—	

Basic (B)

CJ2KB Bore size – Stroke Head cover port location Z

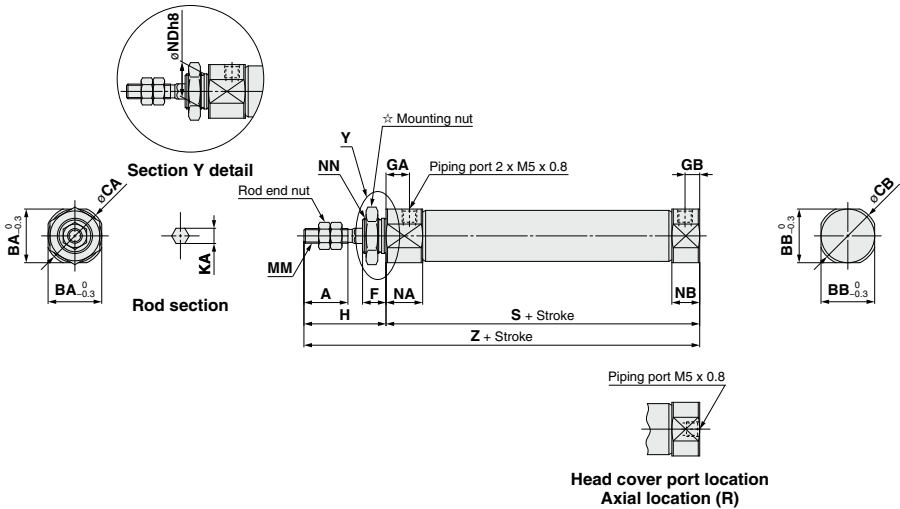

☆ Refer to page 376 for details of the mounting nut. (SNJ-016C for ø10, SNKJ-016C for ø16)

Bore size	A	BA	BB	CA	CB	F	GA	GB	H	KA	MM	NA	NB	NDh8	NN	S	Z
10	15	15	12	17	14	8	8	5	28	4.2	M4 x 0.7	12.5	9.5	10 ⁰ _{-0.022}	M10 x 1.0	46	74
16	15	18.3	18.3	20	20	8	8	5	28	5.2	M5 x 0.8	12.5	9.5	12 ⁰ _{-0.027}	M12 x 1.0	47	75

Double-side Bossed (E)

CJ2KE Bore size – Stroke Z

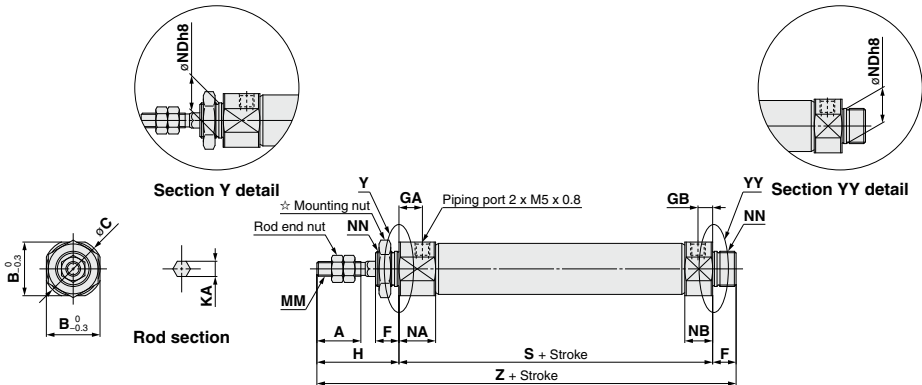

☆ Refer to page 376 for details of the mounting nut. (SNJ-016C for ø10, SNKJ-016C for ø16)

Bore size	A	B	C	F	GA	GB	H	KA	MM	NA	NB	NDh8	NN	S	Z
10	15	15	17	8	8	5	28	4.2	M4 x 0.7	12.5	9.5	10 ⁰ _{-0.022}	M10 x 1.0	46	82
16	15	18.3	20	8	8	5	28	5.2	M5 x 0.8	12.5	9.5	12 ⁰ _{-0.027}	M12 x 1.0	47	83

- Air Cylinders
- CJ2
- CM2
- CG1
- MB
- CA2
- CQ2
- CQS
- Lube-retainer
- JA
- MXH
- MXQ
- MGP
- C□Y
- C□X
- C□1
- C(L)□
- C(L)KU
- CKQ
- CKZN
- WRF

Series CJ2K

Double Clevis (D)

CJ2KD Bore size – Stroke Z

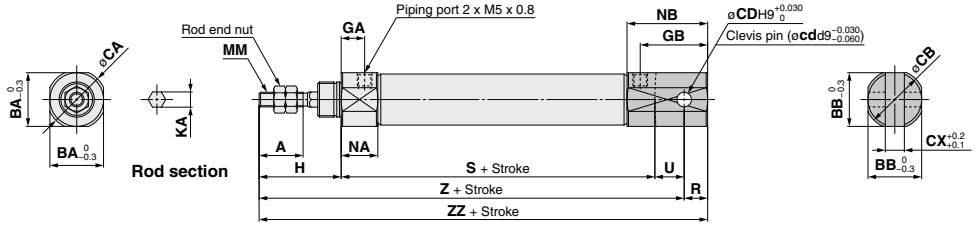

* A clevis pin and retaining rings are included.

Bore size	A	BA	BB	CA	CB	CD(cd)	CX	GA	GB	H	KA	MM	NA	NB	R	S	U	Z	ZZ
10	15	15	12	17	14	3.3	3.2	8	18	28	4.2	M4 x 0.7	12.5	22.5	5	46	8	82	87
16	15	18.3	18.3	20	20	5	6.5	8	23	28	5.2	M5 x 0.8	12.5	27.5	8	47	10	85	93

(mm)

Single Foot (L)

CJ2KL Bore size – Stroke Head cover port location Z

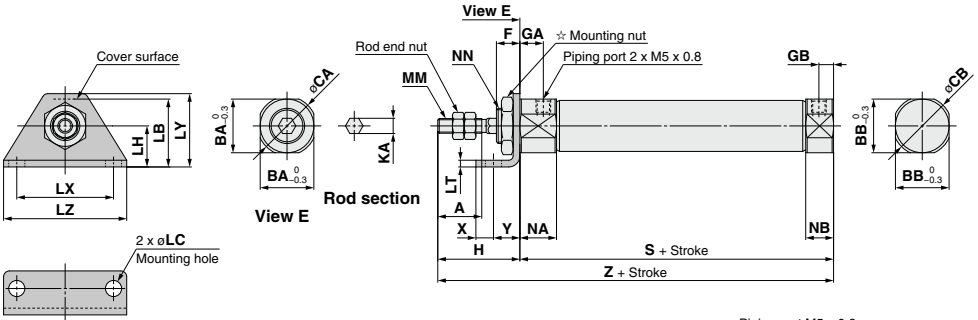

Head cover port location Axial location (R)

* The overall cylinder length does not change.

☆ Refer to page 376 for details of the mounting nut. (SNJ-016C for ø10, SNKJ-016C for ø16)

Bore size	A	BA	BB	CA	CB	F	GA	GB	H	KA	LB	LC	LH	LT	LX	LY	LZ	MM	NA	NB	NN	S	X	Y	Z
10	15	15	12	17	14	8	8	5	28	4.2	21.5	5.5	14	2.3	33	25	42	M4 x 0.7	12.5	9.5	M10 x 1.0	46	6	9	74
16	15	18.3	18.3	20	20	8	8	5	28	5.2	23	5.5	14	2.3	33	25	42	M5 x 0.8	12.5	9.5	M12 x 1.0	47	6	9	75

(mm)

Air Cylinder: Non-rotating Rod Type Double Acting, Single Rod *Series CJ2K*

Double Foot (M)

CJ2KM Bore size – Stroke Z

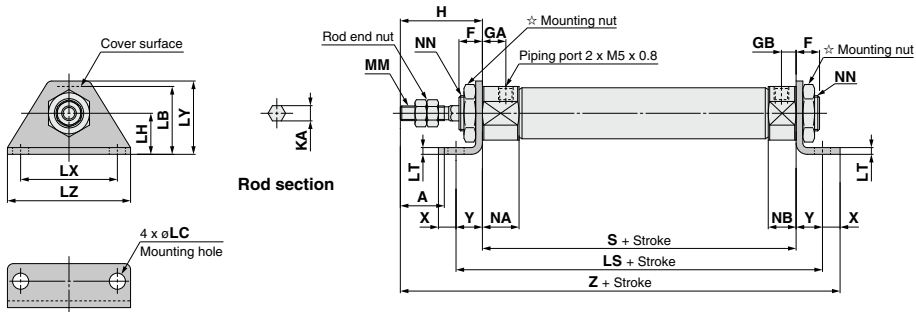

☆ Refer to page 376 for details of the mounting nut. (SNJ-016C for ø10, SNKJ-016C for ø16)

Bore size	(mm)																					
	A	F	GA	GB	H	KA	LB	LC	LH	LS	LT	LX	LY	LZ	MM	NA	NB	NN	S	X	Y	Z
10	15	8	8	5	28	4.2	21.5	5.5	14	64	2.3	33	25	42	M4 x 0.7	12.5	9.5	M10 x 1.0	46	6	9	89
16	15	8	8	5	28	5.2	23	5.5	14	65	2.3	33	25	42	M5 x 0.8	12.5	9.5	M12 x 1.0	47	6	9	90

Rod Flange (F)

CJ2KF Bore size – Stroke Head cover port location Z

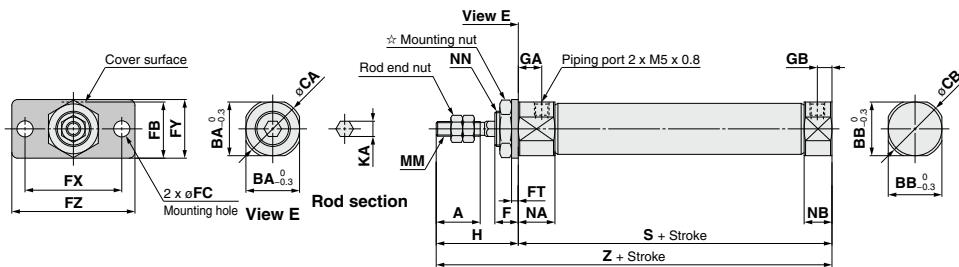

Head cover port location Axial location (R)

☆ The overall cylinder length does not change.

☆ Refer to page 376 for details of the mounting nut. (SNJ-016C for ø10, SNKJ-016C for ø16)

Bore size	(mm)																					
	A	BA	BB	CA	CB	F	FB	FC	FT	FX	FY	FZ	GA	GB	H	KA	MM	NA	NB	NN	S	Z
10	15	15	12	17	14	8	17.5	5.5	2.3	33	20	42	8	5	28	4.2	M4 x 0.7	12.5	9.5	M10 x 1.0	46	74
16	15	18.3	18.3	20	20	8	19	5.5	2.3	33	20	42	8	5	28	5.2	M5 x 0.8	12.5	9.5	M12 x 1.0	47	75

- Air Cylinders
- CJ2**
- CM2
- CG1
- MB
- CA2
- CQ2
- CQS
- Lube-retainer
- JA**
- MXH
- MXQ
- MGP
- C□Y
- C□X
- CK□1
- C(L)□
- C(L)KU
- CKQ
- CKZ2N
- WRF

Series CJ2K

Head Flange (G)

CJ2KG Bore size – Stroke Z

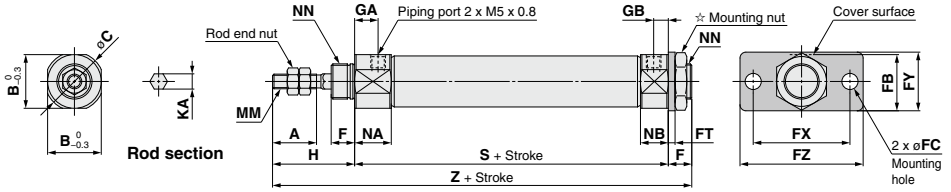

☆ Refer to page 376 for details of the mounting nut. (SNJ-016C for ø10, SNKJ-016C for ø16)

(mm)

Bore size	A	B	C	F	FB	FC	FT	FX	FY	FZ	GA	GB	H	KA	MM	NA	NB	NN	S	Z
10	15	15	17	8	17.5	5.5	2.3	33	20	42	8	5	28	4.2	M4 x 0.7	12.5	9.5	M10 x 1.0	46	82
16	15	18.3	20	8	19	5.5	2.3	33	20	42	8	5	28	5.2	M5 x 0.8	12.5	9.5	M12 x 1.0	47	83

Air Cylinder: Non-rotating Rod Type Single Acting, Spring Return/Extend

Series CJ2K

ø10, ø16



Air Cylinders

- CJ2
- CM2
- CG1
- MB
- CA2
- CQ2
- CQS
- Lube-retainer
- JA
- MXH
- MXQ
- MGP
- CXY
- CXX
- CK1

How to Order



Cylinder standard stroke (mm)
Refer to "Standard Strokes" on page 407.

Action

S	Single acting, Spring return
T	Single acting, Spring extend

CJ2K B 16 - 45 S [] [] [] [] [] [] [] [] [] []

With auto switch CDJ2K B 16 - 45 S [] [] [] [] [] [] [] [] [] [] **M9BW** [] [] **B** [] [] [] [] [] [] [] [] [] []

With auto switch (Built-in magnet)

Mounting

B	Basic
E	Double-side bossed
D	Double clevis
L	Single foot
M	Double foot
F	Rod flange
G	Head flange

Bore size

10	10 mm
16	16 mm

Pivot bracket

Nil	None
N	Pivot bracket is shipped together with the product, but not assembled.

Auto switch
* For applicable auto switches, refer to the table below.

Auto switch mounting type

A	Rail mounting
B	Band mounting

* Foot/Flange brackets are shipped together with the product, but not assembled.

* Only for CJ2D (double clevis)
* Pivot bracket is shipped together with the product, but not assembled.

★ If a built-in magnet cylinder without an auto switch is required, refer to the model of built-in magnet cylinder.

* For rail mounting, screws and nuts for 2 auto switches come with the rail.
* Refer to page 459 for auto switch mounting brackets.

Head cover port location

Nil	Perpendicular to axis	
R	Axial	

Rod end bracket

Nil	None
V	Single knuckle joint
W	Double knuckle joint
T	Rod end cap (Flat type)
U	Rod end cap (Round type)

* Rod end bracket is shipped together with the product, but not assembled.
* A knuckle joint pin is not provided with the single knuckle joint.

Number of auto switches

Nil	2 pcs.
S	1 pc.
n	"n" pcs.

* For double clevis, the product is perpendicular to the cylinder axis.
* For double-side bossed, the product is perpendicular to the cylinder axis.
* Not applicable to single acting, spring extend (T).

★ Refer to "Ordering Example of Cylinder Assembly" on page 407.

Applicable Auto Switches/Refer to the WEB catalog or the Best Pneumatics No. 2 for further information on auto switches.

Type	Special function	Electrical entry	Indicating light	Wiring (Output)	Load voltage		Auto switch model				Lead wire length (m)					Pre-wired connector	Applicable load
					DC	AC	Band mounting		Rail mounting		0.5 (Nil)	1 (M)	3 (L)	5 (Z)	None (N)		
							Perpendicular	In-line	Perpendicular	In-line							
Solid state auto switch	—	Grommet	No	3-wire (NPN)	5 V, 12 V	—	M9NV	M9N	M9NV	M9N	●	●	●	○	○	IC circuit	Relay, PLC
				3-wire (PNP)			M9PV	M9P	M9PV	M9P	●	●	●	○	○		
		Connector	Yes	2-wire	12 V	—	M9BV	M9B	M9BV	M9B	●	●	●	○	○	—	
				—	—	H7C	J79C	—	—	—	—	—	—	—	—		
	Diagnostic indication (2-color indication)	Grommet	Yes	3-wire (NPN)	5 V, 12 V	—	M9NVV	M9NW	M9NVV	M9NW	●	●	●	○	○	IC circuit	
				3-wire (PNP)			M9PWW	M9PW	M9PWW	M9PW	●	●	●	○	○		
		Connector	No	2-wire	12 V	—	M9BWW	M9BW	M9BWW	M9BW	●	●	●	○	○	—	
				—	—	—	—	—	—	—	—	—	—	—	—		
Water resistant (2-color indication)	Grommet	No	3-wire (NPN)	5 V, 12 V	—	M9NAV**	M9NA**	M9NAV**	M9NA**	○	○	●	○	○	IC circuit		
			3-wire (PNP)			M9PAV**	M9PA**	M9PAV**	M9PA**	○	○	●	○	○			
	Connector	Yes	2-wire	12 V	—	M9BAV**	M9BA**	M9BAV**	M9BA**	○	○	○	○	○	—		
			—	—	—	—	—	—	—	—	—	—	—	—	—		
With diagnostic output (2-color indication)	Grommet	No	4-wire (NPN)	5 V, 12 V	—	—	H7NF	—	F79F	●	—	●	○	○	IC circuit		
			—			—	—	—	—	—	—	—	—	—		—	
	Connector	Yes	3-wire (NPN equivalent)	—	5 V	—	A96V	A96	A96V	A96	●	—	●	—	—	IC circuit	
							—	—	—	—	—	—	—	—	—		—
Reed auto switch	—	Grommet	No	2-wire	24 V	12 V	—	—	A72	A72H	●	—	—	—	—	IC circuit	
							—	—	A93V	A93	A93V	A93	●	—	●		—
	Connector	Yes	No	—	—	—	100 V or less	A90V	A90	A90V	A90	●	—	●	—	IC circuit	
							—	—	C73C	A73C	—	—	—	—	—		—
Diagnostic indication (2-color indication)	Grommet	No	No	—	—	—	24 V or less	C80C	A80C	—	—	—	—	—	IC circuit		
							—	—	—	A79W	—	—	—	—		—	—

** Water resistant type auto switches can be mounted on the above models, but in such case SMC cannot guarantee water resistance.
Please contact SMC regarding water resistant types with the above model numbers.

* Lead wire length symbols: 0.5 m..... Nil (Example) M9NV
1 m..... M (Example) M9NWV
3 m..... L (Example) M9NWL
5 m..... Z (Example) M9NWZ
None..... N (Example) H7CN

* Since there are other applicable auto switches than listed, refer to page 460 for details.
* For details about auto switches with pre-wired connector, refer to the WEB catalog or the Best Pneumatics No. 2.

* Solid state auto switches marked with "○" are produced upon receipt of order.
* The D-A90□/M9□□□/A70□/A80□/F70□/J70□ auto switches are shipped together, (but not assembled). (For band mounting, only auto switch mounting brackets are assembled before being shipped.)



INDEX

Series CJ2K

A cylinder which rod does not rotate because of the hexagonal rod shape.

Non-rotating accuracy

∅10: ±1.5°, ∅16: ±1°

Can operate without lubrication.

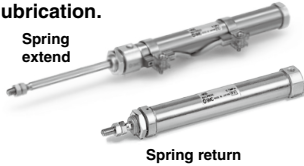

Symbol

Single acting, Spring return, Rubber bumper

Single acting, Spring extend, Rubber bumper



Made to Order
(For details, refer to pages 463 to 472.)

Symbol	Specifications
-XA□	Change of rod end shape
-XC51	With hose nipple
-XC85	Grease for food processing equipment
-X446	PTFE grease

Precautions

Refer to page 473 before handling.

Ordering Example of Cylinder Assembly

Cylinder model: CDJ2KD16-45SZ-NW-M9BW-B

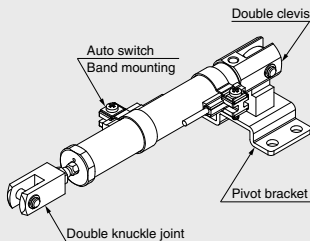

Mounting D: Double clevis
Pivot bracket N: Yes
Rod end bracket W: Double knuckle joint
Auto switch D-M9BW: 2 pcs.
Auto switch mounting B: Band mounting

* Pivot bracket, double knuckle joint and auto switch are shipped together with the product, but not assembled.

Specifications

Bore size (mm)	10	16
Action	Single acting, Spring return/Single acting, Spring extend	
Fluid	Air	
Proof pressure	1 MPa	
Maximum operating pressure	0.7 MPa	
Minimum operating pressure	0.15 MPa	
Ambient and fluid temperature	Without auto switch: -10°C to 70°C (No freezing) With auto switch: -10°C to 60°C	
Cushion	Rubber bumper (required equipment)	
Lubrication	Not required (Non-lube)	
Stroke length tolerance	+1.0	
Rod non-rotating accuracy	±1.5°	±1°
Piston speed	50 to 750 mm/s	
Allowable kinetic energy	0.035 J	0.090 J

Standard Strokes

Bore size	Standard stroke (mm)
10	15, 30, 45, 60
16	15, 30, 45, 60, 75, 100, 125, 150

- * Manufacture of intermediate strokes at 1 mm intervals is possible. (Spacers are not used.)
- * Please consult with SMC for strokes which exceed the standard stroke length.
- * Applicable strokes should be confirmed according to the usage. For details, refer to "Air Cylinders Model Selection" on front matter pages of the Best Pneumatics No. 2 or the **WEB catalog**. In addition, the products that exceed the standard stroke might not be able to fulfill the specifications due to the deflection etc.

Spring Reaction Force

Bore size (mm)	Spring reaction force (N)	
	Primary	Secondary
10	3.53	6.86
16	6.86	14.2

Spring with primary mounting load

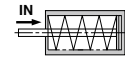

When the spring is set in the cylinder

Spring with secondary mounting load

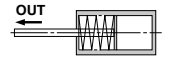

When the spring is contracted by applying air

Mounting and Accessories/For details, refer to page 376.

- Mounted on the product.
- Can be ordered within the cylinder model.

Mounting		Basic	Foot	Flange	Double* clevis	Double clevis (including T-bracket)
Standard	Mounting nut	●	●	●	—	—
	Rod end nut	●	●	●	—	●
	Clevis pin	—	—	—	●	●
Option	Single knuckle joint	○	○	○	○	○
	Double knuckle joint*	○	○	○	○	○
	Rod end cap (Flat/Round type)	○	○	○	○	○
	T-bracket	—	—	—	○	●

* A pin and retaining rings are shipped together with double clevis and double knuckle joint.

Mounting Brackets/Part No.

Mounting bracket	Bore size (mm)	
	10	16
Foot	CJ-L016C	CJK-L016C
Flange	CJ-F016C	CJK-F016C
T-bracket*	CJ-T010C	CJ-T016C

* T-bracket is used with double clevis (D).

Refer to pages 453 to 460 for cylinders with auto switches.

- Auto switch proper mounting position (detection at stroke end) and its mounting height
- Minimum stroke for auto switch mounting
- Operating range
- Auto switch mounting brackets/Part no.

Weights

Spring Return

(g)

Bore size (mm)		10				16			
		Basic	Axial piping	Double clevis (including clevis pin)	Head-side bossed	Basic	Axial piping	Double clevis (including clevis pin)	Head-side bossed
Basic weight	15 stroke	30	30	30	31	64	64	70	66
	30 stroke	38	38	38	39	79	79	86	81
	45 stroke	48	48	48	49	97	97	104	99
	60 stroke	58	58	58	59	116	116	122	118
	75 stroke	/				138	138	144	140
	100 stroke					171	171	178	173
	125 stroke					209	209	215	211
	150 stroke					232	232	238	234
Mounting bracket weight	Single foot					8			
	Double foot	16				50			
	Rod flange	5				13			
	Head flange	5				13			
Accessories	Single knuckle joint	17				23			
	Double knuckle joint (including knuckle pin)	25				21			
	Rod end cap (Flat type)	1				2			
	Rod end cap (Round type)	1				2			
	T-bracket	32				50			

* Mounting nut and rod end nut are included in the basic weight.
Note) Mounting nut is not included in the basic weight for the double clevis.

Calculation:

Example) **CJ2KL10-45SZ**

- Basic weight 48 (ø10)
 - Cylinder stroke..... 45 stroke
 - Mounting bracket weight.....8 (Single foot)
- 48 + 8 = 56 g

Spring Extend

(g)

Bore size (mm)		10				16			
		Basic	Axial piping	Double clevis (including clevis pin)	Head-side bossed	Basic	Axial piping	Double clevis (including clevis pin)	Head-side bossed
Basic weight	15 stroke	29	29	31	31	64	64	72	69
	30 stroke	35	35	37	38	79	79	86	83
	45 stroke	44	44	46	46	95	95	103	99
	60 stroke	52	52	54	55	111	111	119	115
	75 stroke	/				133	133	140	137
	100 stroke					163	163	170	167
	125 stroke					198	198	206	202
	150 stroke					219	219	227	223
Mounting bracket weight	Single foot					8			
	Double foot	16				50			
	Rod flange	5				13			
	Head flange	5				13			
Accessories	Single knuckle joint	17				23			
	Double knuckle joint (including knuckle pin)	25				21			
	Rod end cap (Flat type)	1				2			
	Rod end cap (Round type)	1				2			
	T-bracket	32				50			

* Mounting nut and rod end nut are included in the basic weight.
Note) Mounting nut is not included in the basic weight for the double clevis.

Calculation:

Example) **CJ2KL10-45TZ**

- Basic weight 44 (ø10)
 - Cylinder stroke..... 45 stroke
 - Mounting bracket weight.....8 (Single foot)
- 44 + 8 = 52 g

Air Cylinders

CJ2

CM2

CG1

MB

CA2

CQ2

CQS

Lube-retainer

JA

MXH

MXQ

MGP

C□Y

C□X

CK□1

C(L)□

C(L)□U

CKQ

CKZ2N

WRF

Series CJ2K

Construction (Not able to disassemble)

Single acting, Spring return

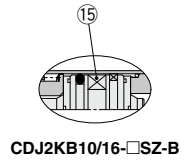
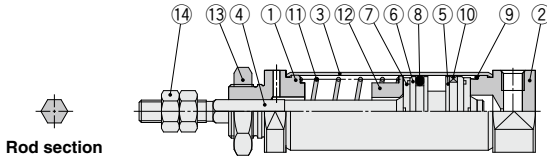

CDJ2KB10/16-□SZ-B

Single acting, Spring extend

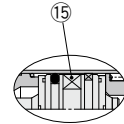
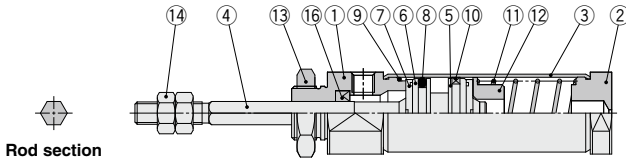

CDJ2BK10/16-□TZ-B

Component Parts

No.	Description	Material	Note
1	Rod cover	Aluminum alloy	Clear hard anodized
2	Head cover	Aluminum alloy	Clear hard anodized
3	Cylinder tube	Stainless steel	
4	Piston rod	Stainless steel	
5	Piston A	Aluminum alloy	
6	Piston B	Aluminum alloy	
7	Bumper	Urethane	
8	Piston seal	NBR	

No.	Description	Material	Note
9	Tube gasket	NBR	
10	Wear ring	Resin	
11	Return spring	Piano wire	Zinc chromated
12	Spring seat	Aluminum alloy	
13	Mounting nut	Rolled steel	Zinc chromated
14	Rod end nut	Rolled steel	Zinc chromated
15	Magnet	—	
16	Rod seal	NBR	

Single Acting, Spring Return: Basic (B)

CJ2KB Bore size – Stroke S Head cover port location Z

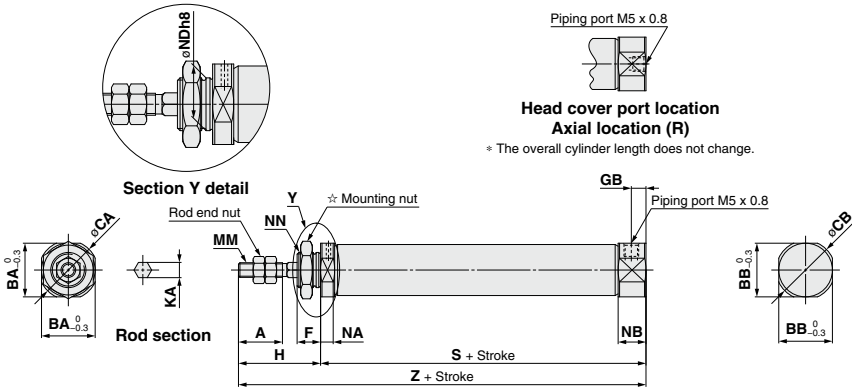

☆ For details of the mounting nut, refer to page 376.

Bore size	A	BA	BB	CA	CB	F	GB	H	KA	MM	NA	NB	NDh8	NN	S								Z							
															5 to 15 st	16 to 30 st	31 to 45 st	46 to 60 st	61 to 75 st	76 to 100 st	101 to 125 st	126 to 150 st	5 to 15 st	16 to 30 st	31 to 45 st	46 to 60 st	61 to 75 st	76 to 100 st	101 to 125 st	126 to 150 st
10	15	15	12	17	14	8	5	28	4.2	M4 x 0.7	4.8	9.5	10 ^{0.022}	M10 x 1.0	45.5	53	65	77	—	—	—	—	73.5	81	93	105	—	—	—	—
16	15	18.3	18.3	20	20	8	5	28	5.2	M5 x 0.8	4.8	9.5	12 ^{0.027}	M12 x 1.0	45.5	54	66	78	84	108	126	138	73.5	82	94	106	112	136	154	166

(mm)

Single Acting, Spring Return: Double-side Bossed (E)

CJ2KE Bore size – Stroke SZ

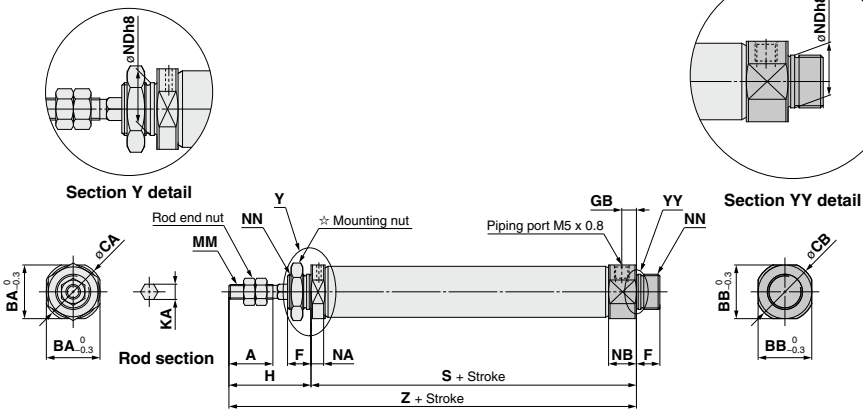

☆ For details of the mounting nut, refer to page 376.

Bore size	A	BA	BB	CA	CB	F	GB	H	KA	MM	NA	NB	NDh8	NN	S								Z							
															5 to 15 st	16 to 30 st	31 to 45 st	46 to 60 st	61 to 75 st	76 to 100 st	101 to 125 st	126 to 150 st	5 to 15 st	16 to 30 st	31 to 45 st	46 to 60 st	61 to 75 st	76 to 100 st	101 to 125 st	126 to 150 st
10	15	15	15	17	17	8	5	28	4.2	M4 x 0.7	4.8	9.5	10 ^{0.022}	M10 x 1.0	45.5	53	65	77	—	—	—	—	73.5	81	93	105	—	—	—	—
16	15	18.3	18.3	20	20	8	5	28	5.2	M5 x 0.8	4.8	9.5	12 ^{0.027}	M12 x 1.0	45.5	54	66	78	84	108	126	138	73.5	82	94	106	112	136	154	166

(mm)

- Air Cylinders
- CJ2**
- CM2
- CG1
- MB
- CA2
- CQ2
- CQS
- Lube-retainer
- JA**
- MXH
- MXQ
- MGP
- C□Y
- C□X
- CK□1
- C(L)□
- C(L)KU
- CKQ
- CKZ2N
- WRF

INDEX

Series CJ2K

Single Acting, Spring Return: Head Flange (G)

CJ2KG Bore size – Stroke SZ

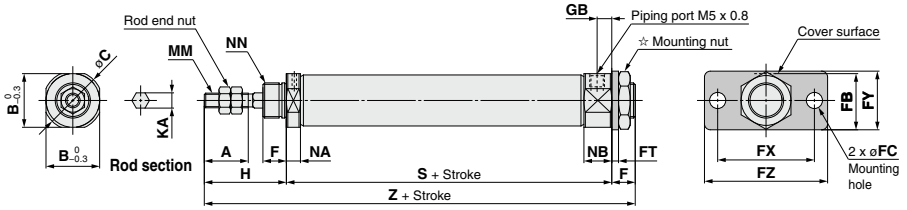

☆ For details of the mounting nut, refer to page 376.

(mm)

Bore size	A	B	C	F	FB	FC	FT	FX	FY	FZ	GB	H	KA	MM	NA	NB	NN
10	15	15	17	8	17.5	5.5	2.3	33	20	42	5	28	4.2	M4 x 0.7	4.8	9.5	M10 x 1.0
16	15	18.3	20	8	19	5.5	2.3	33	20	42	5	28	5.2	M5 x 0.8	4.8	9.5	M12 x 1.0

Bore size	S								Z							
	5 to 15 st	16 to 30 st	31 to 45 st	46 to 60 st	61 to 75 st	76 to 100 st	101 to 125 st	126 to 150 st	5 to 15 st	16 to 30 st	31 to 45 st	46 to 60 st	61 to 75 st	76 to 100 st	101 to 125 st	126 to 150 st
10	45.5	53	65	77	—	—	—	—	81.5	89	101	113	—	—	—	—
16	45.5	54	66	78	84	108	126	138	81.5	90	102	114	120	144	162	174

Series CJ2K

Single Acting, Spring Extend: Double Clevis (D)

CJ2KD Bore size – Stroke TZ

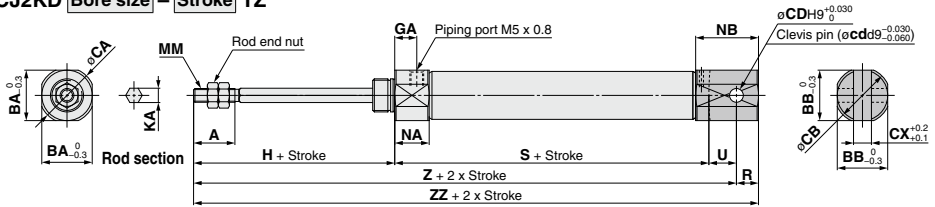

* A clevis pin and retaining rings are included.

Bore size	A	BA	BB	CA	CB	CD (cd)	CX	GA	H	KA	MM	NA	NB	R	U	S							
																5 to 15 st	16 to 30 st	31 to 45 st	46 to 60 st	61 to 75 st	76 to 100 st	101 to 125 st	126 to 150 st
10	15	15	12	17	14	3.3	3.2	8	28	4.2	M4 x 0.7	12.5	17.8	5	8	48.5	56	68	80	—	—	—	
16	15	18.3	18.3	20	20	5	6.5	8	28	5.2	M5 x 0.8	12.5	22.8	8	10	48.5	57	69	81	87	111	129	141

Bore size	Z								ZZ							
	5 to 15 st	16 to 30 st	31 to 45 st	46 to 60 st	61 to 75 st	76 to 100 st	101 to 125 st	126 to 150 st	5 to 15 st	16 to 30 st	31 to 45 st	46 to 60 st	61 to 75 st	76 to 100 st	101 to 125 st	126 to 150 st
10	84.5	92	104	116	—	—	—	—	89.5	97	109	121	—	—	—	—
16	86.5	95	107	119	125	149	167	179	94.5	103	115	127	133	157	175	187

Single Acting, Spring Extend: Single Foot (L)

CJ2KL Bore size – Stroke TZ

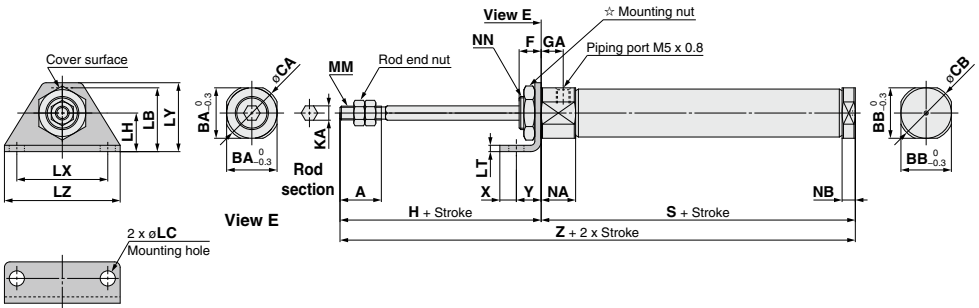

☆ For details of the mounting nut, refer to page 376.

Bore size	A	BA	BB	CA	CB	F	GA	H	KA	LB	LC	LH	LT	LX	LY	LZ	MM	NA	NB	NN
16	15	18.3	18.3	20	20	8	8	28	5.2	23	5.5	14	2.3	33	25	42	M5 x 0.8	12.5	4.8	M12 x 1.0

Bore size	S																X	Y			
	5 to 15 st	16 to 30 st	31 to 45 st	46 to 60 st	61 to 75 st	76 to 100 st	101 to 125 st	126 to 150 st	5 to 15 st	16 to 30 st	31 to 45 st	46 to 60 st	61 to 75 st	76 to 100 st	101 to 125 st	126 to 150 st					
10	48.5	56	68	80	—	—	—	—	6	9	76.5	84	96	108	—	—	—	—	—	—	—
16	48.5	57	69	81	87	111	129	141	6	9	76.5	85	97	109	115	139	157	169	—	—	—

Single Acting, Spring Extend: Double Foot (M)

CJ2KM **Bore size** – **Stroke** TZ

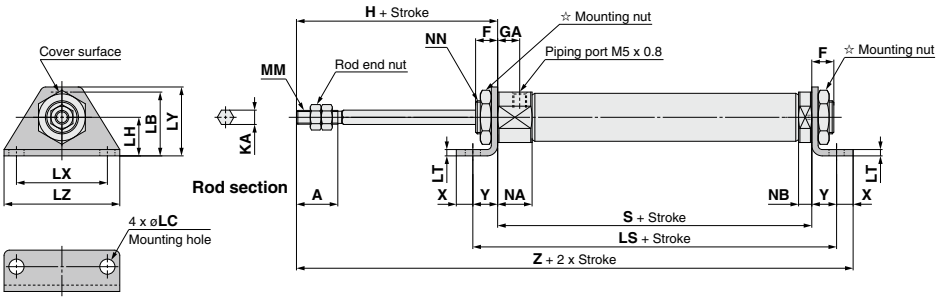

☆ For details of the mounting nut, refer to page 376.

Bore size	A	F	GA	H	KA	LB	LC	LH	LS								LT	LX	LY	LZ	MM	NA	NB	NN
									5 to 15 st	16 to 30 st	31 to 45 st	46 to 60 st	61 to 75 st	76 to 100 st	101 to 125 st	126 to 150 st								
10	15	8	8	28	4.2	21.5	5.5	14	66.5	74	86	98	—	—	—	2.3	33	25	42	M4 x 0.7	12.5	4.8	M10 x 1.0	
16	15	8	8	28	5.2	23	5.5	14	66.5	74	86	99	105	129	147	159	2.3	33	25	42	M5 x 0.8	12.5	4.8	M12 x 1.0

Bore size	S						X	Y	Z									
	5 to 15 st	16 to 30 st	31 to 45 st	46 to 60 st	61 to 75 st	76 to 100 st			101 to 125 st	126 to 150 st	5 to 15 st	16 to 30 st	31 to 45 st	46 to 60 st	61 to 75 st	76 to 100 st	101 to 125 st	126 to 150 st
10	48.5	56	68	80	—	—	6	9	91.5	99	111	123	—	—	—	—	—	
16	48.5	57	69	81	87	111	129	141	6	9	91.5	100	112	124	130	154	172	184

Single Acting, Spring Extend: Rod Flange (F)

CJ2KF **Bore size** – **Stroke** TZ

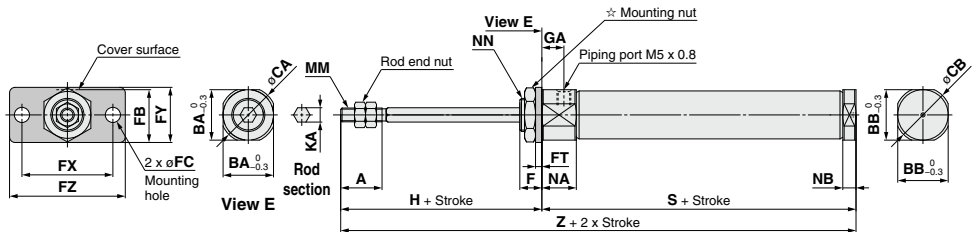

☆ For details of the mounting nut, refer to page 376.

Bore size	A	BA	BB	CA	CB	F	FB	FC	FT	FX	FY	FZ	GA	H	KA	MM	NA	NB	NN
16	15	18.3	18.3	20	20	8	19	5.5	2.3	33	20	42	8	28	5.2	M5 x 0.8	12.5	4.8	M12 x 1.0

Bore size	S						Z									
	5 to 15 st	16 to 30 st	31 to 45 st	46 to 60 st	61 to 75 st	76 to 100 st	101 to 125 st	126 to 150 st	5 to 15 st	16 to 30 st	31 to 45 st	46 to 60 st	61 to 75 st	76 to 100 st	101 to 125 st	126 to 150 st
10	48.5	56	68	80	—	—	—	—	76.5	84	96	108	—	—	—	—
16	48.5	57	69	81	87	111	129	141	76.5	85	97	109	115	139	157	169

- Air Cylinders
- CJ2
- CM2
- CG1
- MB
- CA2
- CQ2
- CQS
- Lube-retainer
- JA
- MXH
- MXQ
- MGP
- C□Y
- C□X
- CK□1
- C(L)□
- C(L)KU
- CKQ
- CKZ2N
- WRF

INDEX

Series CJ2K

Single Acting, Spring Extend: Head Flange (G)

CJ2KG Bore size – Stroke TZ

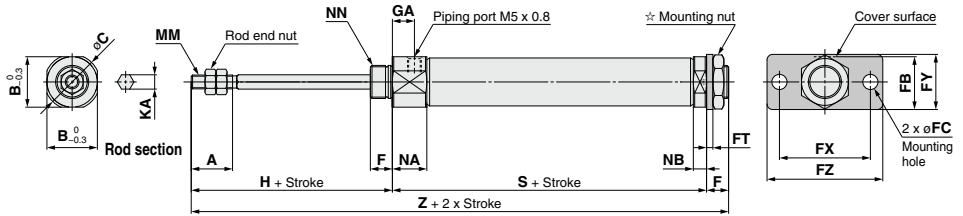

☆ For details of the mounting nut, refer to page 376.

(mm)

Bore size	A	B	C	F	FB	FC	FT	FX	FY	FZ	GA	H	KA	MM	NA	NB	NN
10	15	15	17	8	17.5	5.5	2.3	33	20	42	8	28	4.2	M4 x 0.7	12.5	4.8	M10 x 1.0
16	15	18.3	20	8	19	5.5	2.3	33	20	42	8	28	5.2	M5 x 0.8	12.5	4.8	M12 x 1.0

Bore size	S										Z					
	5 to 15 st	16 to 30 st	31 to 45 st	46 to 60 st	61 to 75 st	76 to 100 st	101 to 125 st	126 to 150 st	5 to 15 st	16 to 30 st	31 to 45 st	46 to 60 st	61 to 75 st	76 to 100 st	101 to 125 st	126 to 150 st
10	48.5	56	68	80	—	—	—	—	84.5	92	104	116	—	—	—	—
16	48.5	57	69	81	87	111	129	141	84.5	93	105	117	123	147	165	177

Air Cylinder: Built-in Speed Controller Type Double Acting, Single Rod

Series CJ2Z ø10, ø16



Air Cylinders

How to Order



Bore size

10	10 mm
16	16 mm

Cylinder standard stroke (mm)
Refer to "Standard Strokes" on page 419.

Ordering Example: CJ2Z B 16 - 60 Z - [] - [] - []

With auto switch: CDJ2Z B 16 - 60 Z - [] - [] - M9BW [] - B - []

With auto switch (Built-in magnet): [] - [] - [] - M9BW [] - B - []

Mounting

B	Basic
E	Double-side bossed
D	Double clevis
L	Single foot
M	Double foot
F	Rod flange
G	Head flange

* Foot/Flange brackets are shipped together with the product, but not assembled.

Pivot bracket

Nil	None
N	Pivot bracket is shipped together with the product, but not assembled.

* Only for CJ2D (double clevis)
* Pivot bracket is shipped together with the product, but not assembled.

Auto switch

* For applicable auto switches, refer to the table below.

Auto switch mounting type

A	Rail mounting
B	Band mounting

* For rail mounting, screws and nuts for 2 auto switches come with the rail.
* Refer to page 459 for auto switch mounting brackets.

Number of auto switches

Nil	2 pcs.
S	1 pc.
n	"n" pcs.

Rod end bracket

Nil	None
W	Single knuckle joint
V	Double knuckle joint
T	Rod end cap (Flat type)
U	Rod end cap (Round type)

* Rod end bracket is shipped together with the product, but not assembled.
* A knuckle joint pin is not provided with the single knuckle joint.

Head cover port location

Nil	Perpendicular to axis
R	Axial

* For double clevis, the product is perpendicular to the cylinder axis.
* For double-side bossed, the product is perpendicular to the cylinder axis.

Made to Order
Refer to page 419 for details.

*** Refer to "Ordering Example of Cylinder Assembly" on page 419.**

Applicable Auto Switches (Refer to the WEB catalog or the Best Pneumatics No. 2 for further information on auto switches.)

Type	Special function	Electrical entry	Indicating light	Wiring (Output)	Load voltage		Auto switch model				Lead wire length (m)					Pre-wired connector	Applicable load
					DC	AC	Band mounting		Rail mounting		0.5 (Nil)	1 (M)	3 (Z)	5 (N)			
Solid state auto switch	—	Grommet	No	3-wire (NPN)	5 V, 12 V	—	M9NV	M9N	M9NV	M9N	●	●	●	○	○	IC circuit	
				3-wire (PNP)			M9PV	M9P	M9PV	M9P	●	●	●	○	○		
		Connector		2-wire	12 V	—	M9BV	M9B	M9BV	M9B	●	●	●	○	○		—
				—	—	—	H7C	J79C	—	—	—	—	—	—	—		
	Diagnostic indication (2-color indication)	Grommet	Yes	3-wire (NPN)	5 V, 12 V	24 V	—	M9NV	M9NW	M9NV	M9NW	●	●	●	○	○	IC circuit
				3-wire (PNP)			M9PW	M9PW	M9PW	M9PW	●	●	●	○	○		
		Connector		2-wire	12 V	—	M9BV	M9B	M9BV	M9B	●	●	●	○	○	—	
				3-wire (NPN)	5 V, 12 V	—	M9NAV**	M9NA**	M9NAV**	M9NA**	○	○	○	○	○		IC circuit
Water resistant (2-color indication)	Grommet	No	3-wire (PNP)	5 V, 12 V	—	M9PAV**	M9PA**	M9PAV**	M9PA**	○	○	○	○	○	IC circuit		
			3-wire (NPN)			M9BAV**	M9BA**	M9BAV**	M9BA**	○	○	○	○	○			
With diagnostic output (2-color indication)	Connector		2-wire	12 V	—	M9BAV**	M9BA**	M9BAV**	M9BA**	○	○	○	○	○	—		
			4-wire (NPN)	5 V, 12 V	—	H7NF	—	F79F	—	●	●	○	○	○		IC circuit	
Reed auto switch	—	Grommet	Yes	3-wire (NPN equivalent)	5 V	—	A96V	A96	A96V	A96	●	●	●	—	—	IC circuit	
				—			—	—	A72	A72H	●	●	●	—	—		
		Connector		2-wire	24 V	12 V	100 V or less	A93V	A93	A93V	A93	●	●	●	—	—	IC circuit
				—	—	—	—	—	C73C	A73C	—	●	●	●	—	—	
	Diagnostic indication (2-color indication)	Grommet	No	2-wire	24 V or less	—	—	C80C	A80C	—	●	●	●	—	—	IC circuit	
				—			—	—	A79W	—	●	●	●	—	—		
		Connector		2-wire	24 V or less	—	—	—	—	—	—	●	●	●	—	—	—
				—	—	—	—	—	—	—	—	●	●	●	—	—	

** Water resistant type auto switches can be mounted on the above models, but in such case SMC cannot guarantee water resistance.
Please contact SMC regarding water resistant types with the above model numbers.

* Lead wire length symbols: 0.5 m..... Nil (Example) M9NV
1 m..... M (Example) M9NWM
3 m..... L (Example) M9NWL
5 m..... Z (Example) M9NWZ
None..... N (Example) H7CN

* Solid state auto switches marked with "○" are produced upon receipt of order.

* The D-A900/M9000/A700/A800/F700/J700 auto switches are shipped together, (but not assembled). (For band mounting, only auto switch mounting brackets are assembled before being shipped.)

* Since there are other applicable auto switches than listed, refer to page 460 for details.
* For details about auto switches with pre-wired connector, refer to the WEB catalog or the Best Pneumatics No. 2.



CJ2

CM2

CG1

MB

CA2

CQ2

CQS

Lube-retainer

JA

MXH

MXQ

MGP

CY

CX

CK1

CLKJ

CLJKU

CKQ

CKZZN

WRF

INDEX

Series CJ2Z

Space-saving air cylinder with speed controller built-in cylinder cover



Symbol

Double acting, Single rod, Rubber bumper

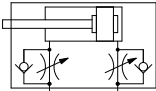

Made to Order

(For details, refer to pages 463 to 472.)

Symbol	Specifications
-XA □	Change of rod end shape
-XC51	With hose nipple
-XC85	Grease for food processing equipment
-X446	PTFE grease



Precautions

Refer to page 473 before handling.

Ordering Example of Cylinder Assembly

Cylinder model: CDJ2ZD16-60Z-NW-M9BW-B

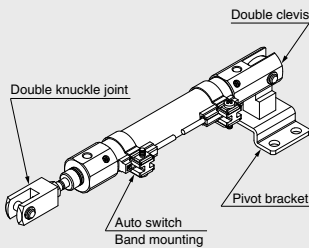

Mounting D: Double clevis
Pivot bracket N: Yes
Rod end bracket W: Double knuckle joint
Auto switch D-M9BW: 2 pcs.
Auto switch mounting B: Band mounting

* Pivot bracket, double knuckle joint and auto switch are shipped together with the product, but not assembled.

Specifications

Bore size (mm)	10	16
Action	Double acting, Single rod	
Fluid	Air	
Proof pressure	1 MPa	
Maximum operating pressure	0.7 MPa	
Minimum operating pressure	0.06 MPa	
Ambient and fluid temperature	Without auto switch : -10°C to 70°C (No freezing) With auto switch : -10°C to 60°C	
Cushion	Rubber bumper	
Lubrication	Not required (Non-lube)	
Stroke length tolerance	+1.0 0	
Speed controller	Built-in	
Piston speed	50 to 750 mm/s	
Allowable kinetic energy	0.035 J	0.090 J

Standard Strokes

Bore size	Standard stroke (mm)	Maximum manufacturable stroke (mm)
10	15, 30, 45, 60, 75, 100, 125, 150	400
16	15, 30, 45, 60, 75, 100, 125, 150, 175, 200	400

- * Manufacture of intermediate strokes at 1 mm intervals is possible. (Spacers are not used.)
- * Applicable strokes should be confirmed according to the usage. For details, refer to "Air Cylinders Model Selection" on front matter pages of the Best Pneumatics No. 2 or the **WEB catalog**. In addition, the products that exceed the standard stroke might not be able to fulfill the specifications due to the deflection etc.

Mounting and Accessories/For details, refer to page 376.

●···Mounted on the product. ○···Can be ordered within the cylinder model.

Mounting		Basic	Foot	Flange	Double [†] clevis	Double clevis (including T-bracket)
Standard	Mounting nut	●	●	●	—	—
	Rod end nut	●	●	●	●	●
	Clevis pin	—	—	—	●	●
Option	Single knuckle joint	○	○	○	○	○
	Double knuckle joint*	○	○	○	○	○
	Rod end cap (Flat/Round type)	○	○	○	○	○
	T-bracket	—	—	—	○	●

- * A pin and retaining rings are shipped together with double clevis and double knuckle joint.

Mounting Brackets/Part No.

Mounting bracket	Bore size (mm)	
	10	16
Foot	CJ-L010C	CJ-L016C
Flange	CJ-F010C	CJ-F016C
T-bracket*	CJ-T010C	CJ-T016C

* T-bracket is used with double clevis (D).

Refer to pages 453 to 460 for cylinders with auto switches.

- * Auto switch proper mounting position (detection at stroke end) and its mounting height
- * Minimum stroke for auto switch mounting
- * Operating range
- * Auto switch mounting brackets/Part no.

Weights

Bore size (mm)		10	16
Basic weight (When the stroke is zero)	Basic	36	61
	Axial piping	36	61
	Double clevis (including clevis pin)	40	68
	Head-side bossed	37	63
Additional weight per 15 mm of stroke		4	7
Mounting bracket weight	Single foot	8	25
	Double foot	16	50
	Rod flange	5	13
	Head flange	5	13
Accessories	Single knuckle joint	17	23
	Double knuckle joint (including knuckle pin)	25	21
	Rod end cap (Flat type)	1	2
	Rod end cap (Round type)	1	2
	T-bracket	32	50

* Mounting nut and rod end nut are included in the basic weight.

Note) Mounting nut is not included in the basic weight for the double clevis.

Calculation:

Example) **CJ2ZL10-45Z**

- Basic weight 36 (ø10)
 - Additional weight 4/15 stroke
 - Cylinder stroke 45 stroke
 - Mounting bracket weight ... 8 (Single foot)
- $36 + 4/15 \times 45 + 8 = 56 \text{ g}$

Construction (Not able to disassemble)

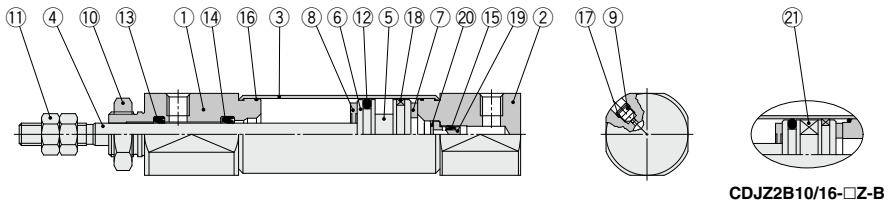

Component Parts

No.	Description	Material	Note
1	Rod cover	Aluminum alloy	Clear hard anodized
2	Head cover	Aluminum alloy	Clear hard anodized
3	Cylinder tube	Stainless steel	
4	Piston rod	Stainless steel	
5	Piston A	Aluminum alloy	
6	Piston B	Aluminum alloy	
7	Bumper A	Urethane	
8	Bumper B	Urethane	
9	Speed controller needle	Carbon steel	Electroless nickel plating
10	Mounting nut	Rolled steel	Zinc chromated
11	Rod end nut	Rolled steel	Zinc chromated

No.	Description	Material	Note
12	Piston seal	NBR	
13	Rod seal	NBR	
14	Check seal A	NBR	
15	Check seal B	NBR	
16	Tube gasket	NBR	
17	Needle seal	NBR	
18	Wear ring	Resin	
19	Check seal sleeve	Aluminum alloy	
20	Retaining ring	Carbon tool steel	Phosphate coating
21	Magnet	—	

Series CJ2Z

Basic (B)

CJ2ZB – Z

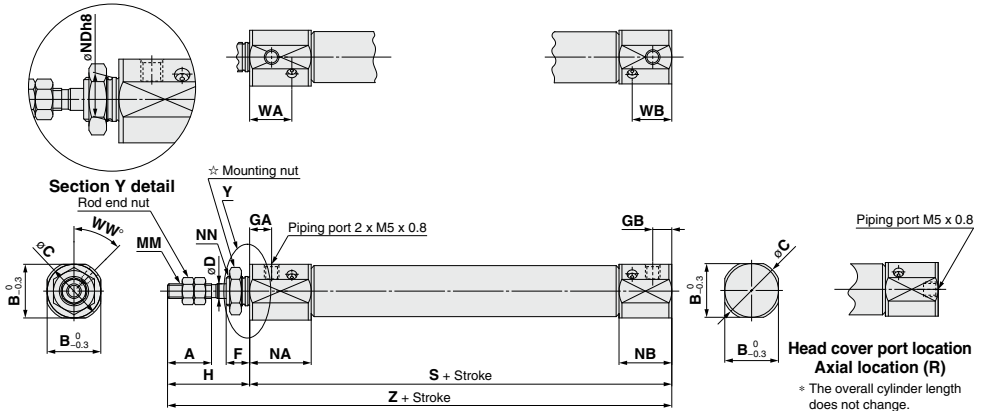

☆ For details of the mounting nut, refer to page 376.

Bore size	A	B	C	D	F	GA	GB	H	MM	NA	NB	NDh8	NN	WA	WB	WW	S	Z
10	15	15	17	4	8	7.5	6.5	28	M4 x 0.7	21	18	8 ⁰ _{-0.022}	M8 x 1.0	14.4	13.5	45	63	91
16	15	18.3	20	5	8	7.5	6.5	28	M5 x 0.8	21	18	10 ⁰ _{-0.022}	M10 x 1.0	14.4	13.5	45	64	92

Double-side Bossed (E)

CJ2ZE – Z

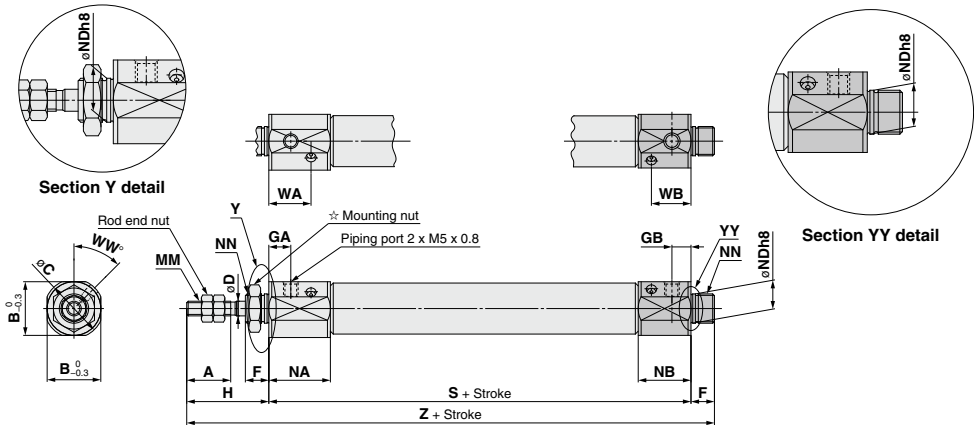

☆ For details of the mounting nut, refer to page 376.

Bore size	A	B	C	D	F	GA	GB	H	MM	NA	NB	NDh8	NN	WA	WB	WW	S	Z
10	15	15	17	4	8	7.5	6.5	28	M4 x 0.7	21	18	8 ⁰ _{-0.022}	M8 x 1.0	14.4	13.5	45	63	99
16	15	18.3	20	5	8	7.5	6.5	28	M5 x 0.8	21	18	10 ⁰ _{-0.022}	M10 x 1.0	14.4	13.5	45	64	100

Air Cylinder: Built-in Speed Controller Type Double Acting, Single Rod *Series CJ2Z*

Double Clevis (D)

CJ2ZD Bore size – Stroke Z

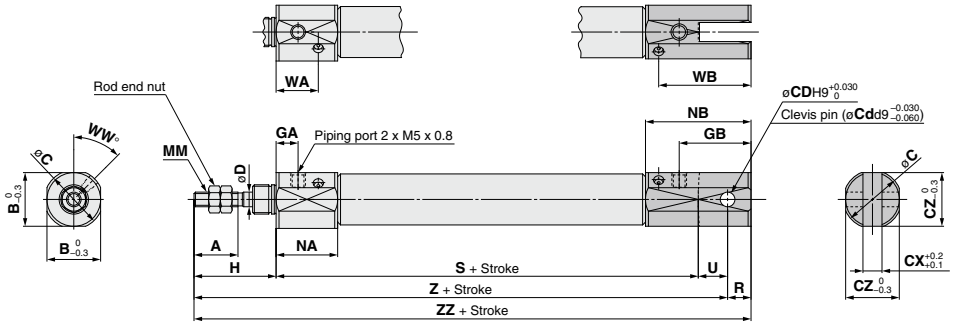

* A clevis pin and retaining rings are included.

Bore size	(mm)																				
	A	B	C	CD	CX	CZ	D	GA	GB	H	MM	NA	NB	R	U	WA	WB	WW	S	Z	ZZ
10	15	15	17	3.3	3.2	15	4	7.5	19.5	28	M4 x 0.7	21	31	5	8	14.4	26.5	45	63	99	104
16	15	18.3	20	5	6.5	18.3	5	7.5	24.5	28	M5 x 0.8	21	36	8	10	14.4	31.5	45	64	102	110

Single Foot (L)

CJ2ZL Bore size – Stroke Head cover port location Z

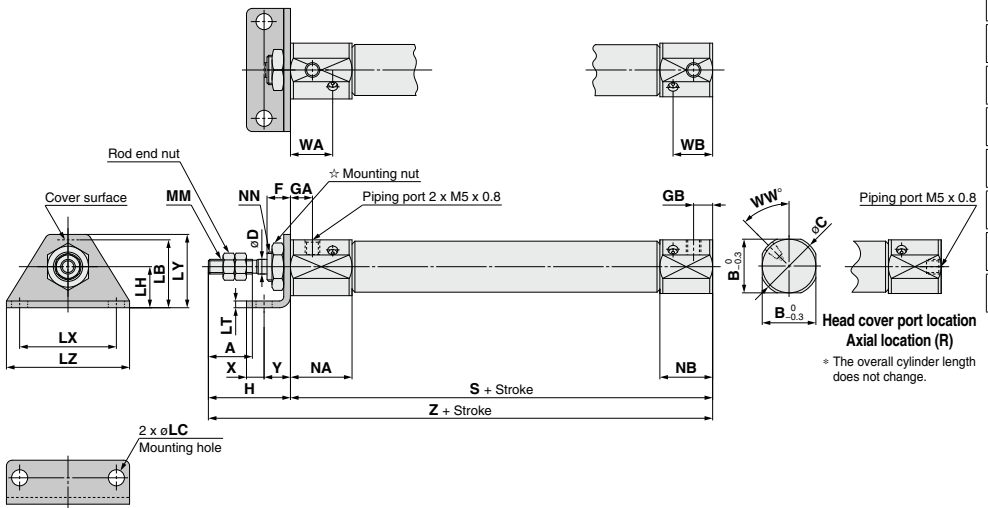

☆ For details of the mounting nut, refer to page 376.

Bore size	(mm)																									
	A	B	C	D	F	GA	GB	H	LB	LC	LH	LT	LX	LY	LZ	MM	NA	NB	NN	WA	WB	WW	S	X	Y	Z
10	15	15	17	4	8	7.5	6.5	28	15	4.5	9	1.6	24	16.5	32	M4 x 0.7	21	18	M8 x 1.0	14.4	13.5	45	63	5	7	91
16	15	18.3	20	5	8	7.5	6.5	28	23	5.5	14	2.3	33	25	42	M5 x 0.8	21	18	M10 x 1.0	14.4	13.5	45	64	6	9	92

Air Cylinders

CJ2

CM2

CG1

MB

CA2

CQ2

CQS

JA

MXH

MXQ

MGP

CY

CX

CK1

CKL

CKLU

CKQ

CKZN

WRF

INDEX

Head Flange (G)

CJ2ZG Bore size – Stroke Z

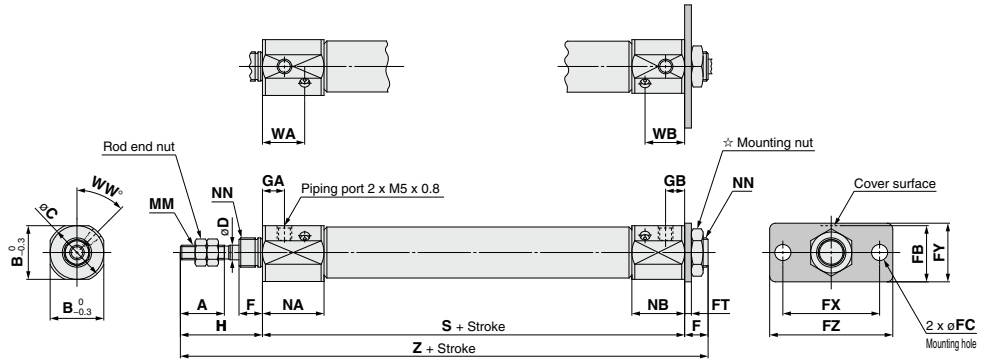

☆ For details of the mounting nut, refer to page 376.

Bore size	(mm)																						
	A	B	C	D	F	FB	FC	FT	FX	FY	FZ	GA	GB	H	MM	NA	NB	NN	WA	WB	WW	S	Z
10	15	15	17	4	8	13	4.5	1.6	24	14	32	7.5	6.5	28	M4 x 0.7	21	18	M8 x 1.0	14.4	13.5	45	63	99
16	15	18.3	20	5	8	19	5.5	2.3	33	20	42	7.5	6.5	28	M5 x 0.8	21	18	M10 x 1.0	14.4	13.5	45	64	100

Air Cylinders

CJ2

CM2

CG1

MB

CA2

CQ2

CQS

JA

MXH

MXQ

MGP

C□Y

C□X

CK□1

C(L)□

C(L)KU

CKQ

CKZ2N

WRF

INDEX

Air Cylinder: Built-in Speed Controller Type Double Acting, Double Rod

Series CJ2ZW

ø10, ø16



How to Order

With auto switch CJ2ZW **B** 16 - 60 Z - []

With auto switch (Built-in magnet) CDJ2ZW **L** 16 - 60 Z - M9BW [] - **B** - []

Mounting

B	Basic
L	Foot
F	Flange

* Foot/Flange brackets are shipped together with the product, but not assembled.

Bore size

10	10 mm
16	16 mm

Cylinder standard stroke (mm)
Refer to "Standard Strokes" on page 426.

Auto switch

Nil	Without auto switch
------------	---------------------

* For applicable auto switches, refer to the table below.

Made to Order
Refer to page 426 for details.

Auto switch mounting type

A	Rail mounting
B	Band mounting

* For rail mounting, screws and nuts for 2 auto switches come with the rail.
* Refer to page 459 for auto switch mounting brackets.

Number of auto switches

Nil	2 pcs.
S	1 pc.
n	"n" pcs.

Applicable Auto Switches/Refer to the WEB catalog or the Best Pneumatics No. 2 for further information on auto switches.

Type	Special function	Electrical entry	Indicator light	Wiring (Output)	Load voltage		Auto switch model				Lead wire length (m)					Pre-wired connector	Applicable load	
					DC	AC	Band mounting		Rail mounting		0.5 (Nil)	1 (M)	3 (L)	5 (Z)	None (N)			
							Perpendicular	In-line	Perpendicular	In-line								
Solid state auto switch	—	Grommet	3-wire (NPN)	3-wire (PNP)	24 V	5 V, 12 V	—	M9NV	M9N	M9NV	M9N	●	●	●	○	○	IC circuit	Relay, PLC
								M9PV	M9P	M9PV	M9P	●	●	●	○	○		
		M9BV	M9B	M9BV				M9B	●	●	●	○	○					
		—	H7C	J79C				—	●	—	●	●	—	—				
	Diagnostic indication (2-color indication)	Grommet	3-wire (NPN)	3-wire (PNP)	24 V	5 V, 12 V	—	M9NWV	M9NW	M9NWV	M9NW	●	●	●	○	○	IC circuit	
								M9PWV	M9PW	M9PWV	M9PW	●	●	●	○	○		
		M9BWW	M9BW	M9BWW				M9BW	●	●	●	○	○					
		—	—	—				—	●	—	●	●	—	—				
Water resistant (2-color indication)	Grommet	3-wire (NPN)	3-wire (PNP)	24 V	5 V, 12 V	—	M9NAV**	M9NA**	M9NAV**	M9NA**	○	○	○	○	○	IC circuit		
							M9PAV**	M9PA**	M9PAV**	M9PA**	○	○	○	○	○			
	M9BAV**	M9BA**	M9BAV**				M9BA**	○	○	○	○	○						
	—	H7NF	—				F79F	●	—	●	●	—	—					
Reed auto switch	—	Grommet	3-wire (NPN equivalent)	24 V	12 V	5 V	—	A96V	A96	A96V	A96	●	—	—	—	IC circuit	Relay, PLC	
								—	200 V	—	—	A72	A72H	●	—			—
		—	100 V					A93V	A93	A93V	A93	●	—	●	—			—
		—	100 V or less					A90V	A90	A90V	A90	●	—	●	—			—
	Diagnostic indication (2-color indication)	Grommet	2-wire	24 V	12 V	24 V or less	—	—	C73C	A73C	—	●	—	●	●	IC circuit		
								—	—	C80C	A80C	—	●	—	●			●
		—	—					—	A79W	—	●	—	●	●	—			
		—	—					—	—	—	●	—	●	●	—			

* Water resistant type auto switches can be mounted on the above models, but in such case SMC cannot guarantee water resistance. Please contact SMC regarding water resistant types with the above model numbers.

* Lead wire length symbols: 0.5 m..... Nil (Example) M9NW
1 m..... M (Example) M9NWM
3 m..... L (Example) M9NWL
5 m..... Z (Example) M9NWX
None..... N (Example) H7CN

* Since there are other applicable auto switches than listed, refer to page 460 for details.

* For details about auto switches with pre-wired connector, refer to the WEB catalog or the Best Pneumatics No. 2.

* Solid state auto switches marked with "○" are produced upon receipt of order.

* The D-A900/M9000/A700/A800/F700/J700 auto switches are shipped together, (but not assembled), (For band mounting, only auto switch mounting brackets are assembled before being shipped.)



Space-saving air cylinder with speed controller built-in cylinder cover



Symbol

Double acting, Double rod, Rubber bumper

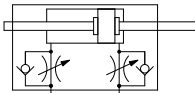

Made to Order
(For details, refer to pages 463 to 472.)

Symbol	Specifications
-XA□	Change of rod end shape
-XC51	With hose nipple
-XC85	Grease for food processing equipment
-X446	PTFE grease

⚠ Precautions

Refer to page 473 before handling.

Specifications

Bore size (mm)	10	16
Action	Double acting, Single rod	
Fluid	Air	
Proof pressure	1 MPa	
Maximum operating pressure	0.7 MPa	
Minimum operating pressure	0.1 MPa	
Ambient and fluid temperature	Without auto switch: -10°C to 70°C (No freezing) With auto switch : -10°C to 60°C (No freezing)	
Cushion	Rubber bumper	
Lubrication	Not required (Non-lube)	
Stroke length tolerance	+1.0 0	
Speed controller	Built-in	
Piston speed	50 to 750 mm/s	
Allowable kinetic energy	0.035 J	0.090 J

Standard Strokes

Bore size	Standard stroke (mm)
10	15, 30, 45, 60, 75, 100, 125, 150
16	15, 30, 45, 60, 75, 100, 125, 150, 175, 200

- * Manufacture of intermediate strokes at 1 mm intervals is possible. (Spacers are not used.)
- * Please consult with SMC for strokes which exceed the standard stroke length.
- * Applicable strokes should be confirmed according to the usage. For details, refer to "Air Cylinders Model Selection" on front matter pages of the Best Pneumatics No. 2 or the **WEB catalog**. In addition, the products that exceed the standard stroke might not be able to fulfill the specifications due to the deflection etc.

Mounting and Accessories /For details, refer to page 376.

		Basic	Foot	Flange
Standard	Mounting nut	●	●	●
	Rod end nut	●	●	●
Option	Single knuckle joint	○	○	○
	Double knuckle joint*	○	○	○

* A knuckle pin and retaining rings are shipped together with double knuckle joint.

Mounting Brackets/Part No.

Mounting bracket	Bore size (mm)	
	10	16
Foot	CJ-L010C	CJ-L016C
Flange	CJ-F010C	CJ-F016C

Refer to pages 453 to 460 for cylinders with auto switches.

- Auto switch proper mounting position (detection at stroke end) and its mounting height
- Minimum stroke for auto switch mounting
- Operating range
- Auto switch mounting brackets/Part no.

Series CJ2ZW

Weights

Bore size (mm)		(g)	
		10	16
Basic weight (When the stroke is zero)	Basic	36	61
	Additional weight per 15 mm of stroke	4.5	7.5
Mounting bracket weight	Double foot	16	50
	Head flange	5	13
Accessories	Single knuckle joint	17	23
	Double knuckle joint (including knuckle pin)	25	21
	Rod end cap (Flat type)	1	2
	Rod end cap (Round type)	1	2

* Mounting nut and rod end nut are included in the basic weight.

Calculation:

Example) **CJ2ZWL10-45Z**

- Basic weight36 (ø10)
- Additional weight4.5/15 stroke
- Cylinder stroke.....45 stroke
- Mounting bracket weight...16 (Double foot)

$$36 + 4.5/15 \times 45 + 16 = 65.5 \text{ g}$$

Construction (Not able to disassemble)

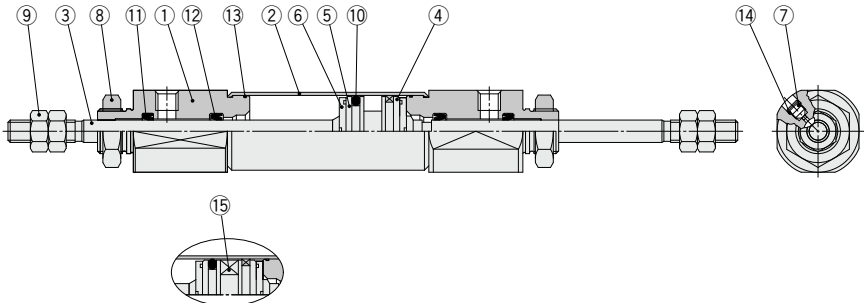

CDJ2ZWB10/16-□Z-B

Component Parts

No.	Description	Material	Note
1	Rod cover	Aluminum alloy	Clear hard anodized
2	Cylinder tube	Stainless steel	
3	Piston rod	Stainless steel	
4	Piston A	Aluminum alloy	
5	Piston B	Aluminum alloy	
6	Bumper	Urethane	
7	Speed controller needle	Carbon steel	Electroless nickel plating
8	Mounting nut	Rolled steel	Zinc chromated

No.	Description	Material	Note
9	Rod end nut	Rolled steel	Zinc chromated
10	Piston seal	NBR	
11	Rod seal	NBR	
12	Check seal	NBR	
13	Tube gasket	NBR	
14	Needle seal	NBR	
15	Magnet	—	

Air Cylinder: Built-in Speed Controller Type Double Acting, Double Rod *Series CJ2ZW*

Basic (B)

CJ2ZWB Bore size – Stroke Z

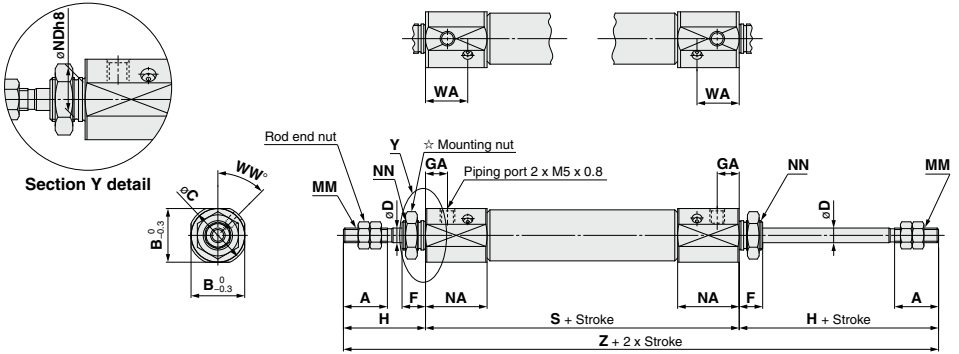

☆ For details of the mounting nut, refer to page 376.

Bore size	A	B	C	D	F	GA	H	MM	NA	NDh8	NN	WA	WW	S	Z
10	15	15	17	4	8	7.5	28	M4 x 0.7	21	8 _{-0.022} ⁰	M8 x 1.0	14.4	45	66	122
16	15	18.3	20	5	8	7.5	28	M5 x 0.8	21	10 _{-0.022} ⁰	M10 x 1.0	14.4	45	67	123

(mm)

Foot (L)

CJ2ZWL Bore size – Stroke Z

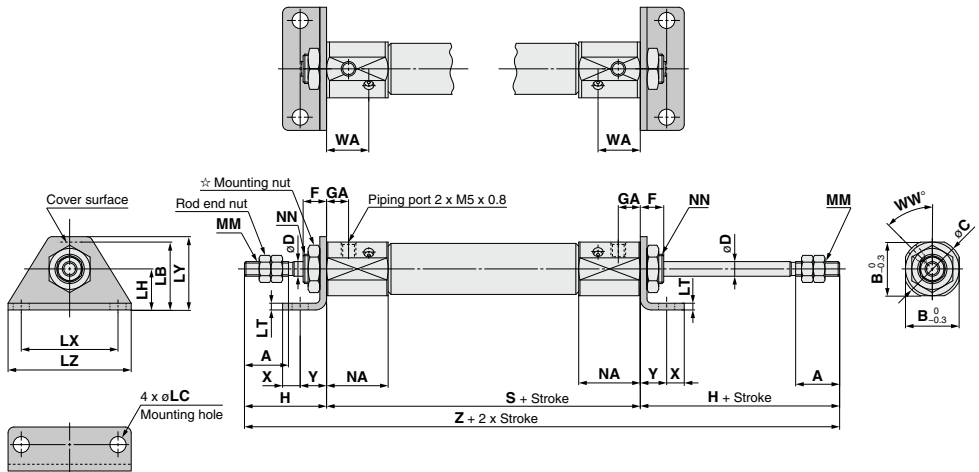

☆ For details of the mounting nut, refer to page 376.

Bore size	A	B	C	D	F	GA	H	LB	LC	LH	LT	LX	LY	LZ	NN	NA	NN	WA	WW	S	X	Y	Z
10	15	15	17	4	8	7.5	28	15	4.5	9	1.6	24	16.5	32	M4 x 0.7	21	M8 x 1.0	14.4	45	66	5	7	122
16	15	18.3	20	5	8	7.5	28	23	5.5	14	2.3	33	25	42	M5 x 0.8	21	M10 x 1.0	14.4	45	67	6	9	123

(mm)

Air Cylinders

CJ2

CM2

CG1

MB

CA2

CQ2

CQS

Lube-retainer

JA

MXH

MXQ

MGP

Y

X

1

(L)

(L)U

CKQ

CKZN

WRF

INDEX

Series CJ2ZW

Flange (F)

CJ2ZWF Bore size – Stroke Z

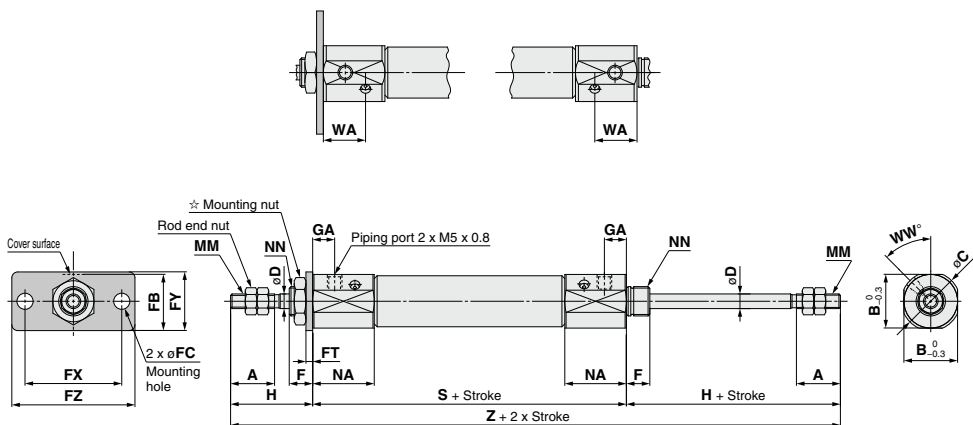

☆ For details of the mounting nut, refer to page 376.

Bore size	A	B	C	D	F	FB	FC	FT	FX	FY	FZ	GA	H	MM	NA	NN	WA	WW	S	Z
10	15	15	17	4	8	13	4.5	1.6	24	14	32	7.5	28	M4 x 0.7	21	M8 x 1.0	14.4	45	66	122
16	15	18.3	20	5	8	19	5.5	2.3	33	20	42	7.5	28	M5 x 0.8	21	M10 x 1.0	14.4	45	67	123

Air Cylinder: Direct Mount Type Double Acting, Single Rod

Series CJ2R ø10, ø16

RoHS



How to Order

Cylinder standard stroke (mm)
Refer to "Standard Strokes" on page 431.

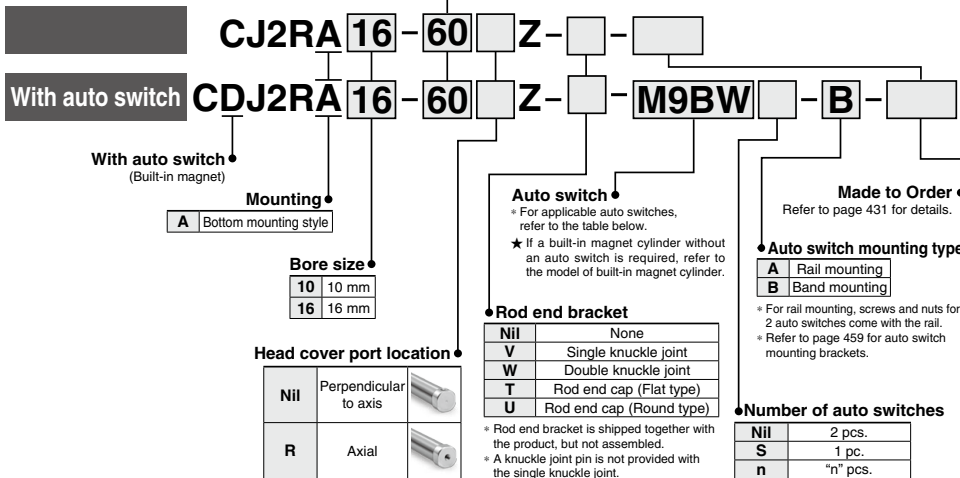

* Refer to "Ordering Example of Cylinder Assembly" on page 431.

Applicable Auto Switches/Refer to the WEB catalog or the Best Pneumatics No. 2 for further information on auto switches.

Type	Special function	Electrical entry	Indicator light	Wiring (Output)	Load voltage		Auto switch model				Lead wire length (m)					Pre-wired connector	Applicable load	
					DC	AC	Band mounting		Rail mounting		0.5 (Nil)	1 (M)	3 (L)	5 (Z)	None (N)			
							Perpendicular	In-line	Perpendicular	In-line								
Solid state auto switch	—	Grommet	No	3-wire (NPN)	5 V, 12 V	—	M9NV	M9N	M9NV	M9N	●	●	○	○	○	IC circuit	Relay, PLC	
				3-wire (PNP)			M9PV	M9P	M9PV	M9P	●	●	○	○				
		Connector	2-wire	12 V	—	M9BV	M9B	M9BV	M9B	●	●	○	○	○				
			—	—	H7C	J79C	—	●	—	●	●	—	—					
	Diagnostic indication (2-color indication)	Grommet	Yes	3-wire (NPN)	5 V, 12 V	—	M9NWV	M9NV	M9NVV	M9NV	●	●	○	○	○	IC circuit		
				3-wire (PNP)			M9PWV	M9PW	M9PWV	M9PW	●	●	○	○	○			
		Connector	2-wire	12 V	—	M9BWW	M9BW	M9BWW	M9BW	●	●	○	○	○				
			—	—	—	—	—	—	—	—	—	—	—	—				
Water resistant (2-color indication)	Grommet	No	3-wire (NPN)	5 V, 12 V	—	M9NAV**	M9NA**	M9NAV**	M9NA**	○	○	○	○	○	IC circuit			
			3-wire (PNP)			M9PAV**	M9PA**	M9PAV**	M9PA**	○	○	○	○	○				
	Connector	2-wire	12 V	—	M9BAV**	M9BA**	M9BAV**	M9BA**	○	○	○	○	○					
		—	—	—	—	—	—	—	—	—	—	—	—					
Reed auto switch	—	Grommet	Yes	3-wire (NPN equivalent)	5 V	—	A96V	A96	A96V	A96	●	—	●	—	—	IC circuit	—	
				—			—	—	A72	A72H	●	—	●	—	—			
		Connector	No	2-wire	24 V	100 V or less	A93V	A93	A93V	A93	●	—	●	—	—			
				—	—	—	A90V	A90	A90V	A90	●	—	●	—	—			
	Diagnostic indication (2-color indication)	Grommet	Yes	—	—	—	—	—	—	—	●	—	●	—	—	IC circuit		
				—			—	—	—	—	—	—	—	—	—			—
		Connector	No	—	—	—	—	—	—	—	—	●	—	●	—			—
				—	—	—	—	—	—	—	—	—	—	—	—			—

** Water resistant type auto switches can be mounted on the above models, but in such case SMC cannot guarantee water resistance. Please contact SMC regarding water resistant types with the above model numbers.

* Lead wire length symbols: 0.5 m..... Nil (Example) M9NW
1 m..... M (Example) M9NWM
3 m..... L (Example) M9NWL
5 m..... Z (Example) M9NWZ

* Since there are other applicable auto switches than listed, refer to page 460 for details.

* For details about auto switches with pre-wired connector, refer to the WEB catalog or the Best Pneumatics No. 2.

* Solid state auto switches marked with "Q" are produced upon receipt of order.

* The D-A90□/M90□□/A70□□/A80□□/F70□□/J70□□ auto switches are shipped together, (but not assembled). (For band mounting, only auto switch mounting brackets are assembled before being shipped.)

Air Cylinders

CJ2

CM2

CG1

MB

CA2

CQ2

CQS

Lube-retainer

JA

MXH

MXQ

MGP

C□X

C□X

CK□1

CL□□

CL□□U

CKQ

CKZ2N

WRF

INDEX

Series CJ2R

The CJ2R direct mount cylinder can be installed directly through the use of a square rod cover.

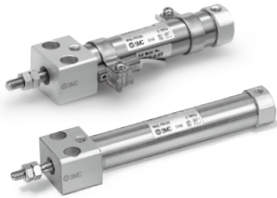

Symbol

Double acting, Single rod, Rubber bumper

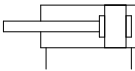

Made to Order

Made to Order

(For details, refer to pages 463 to 472.)

Symbol	Specifications
-XA□	Change of rod end shape
-XC9	Adjustable stroke cylinder/Adjustable retraction type
-XC22	Fluororubber seal
-XC51	With hose nipple
-XC85	Grease for food processing equipment
-X446	PTFE grease



Precautions

Refer to page 473 before handling.

Ordering Example of Cylinder Assembly

Cylinder model: CDJ2RA16-60Z-W-M9BW-B

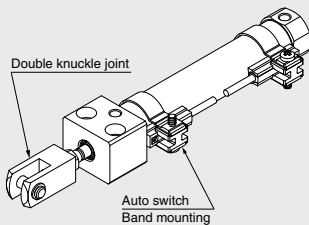

Mounting A: Bottom mounting style
 Rod end bracket W: Double knuckle joint
 Auto switch D-M9BW: 2 pcs.
 Auto switch mounting B: Band mounting

* Double knuckle joint and auto switch are shipped together with the product, but not assembled.

Specifications

Bore size (mm)	10	16
Action	Double acting, Single rod	
Fluid	Air	
Proof pressure	1 MPa	
Maximum operating pressure	0.7 MPa	
Minimum operating pressure	0.06 MPa	
Ambient and fluid temperature	Without auto switch: -10°C to 70°C (No freezing) With auto switch: -10°C to 60°C	
Cushion	Rubber bumper	
Lubrication	Not required (Non-lube)	
Stroke length tolerance	+1.0 0	
Piston speed	50 to 750 mm/s	
Allowable kinetic energy	0.035 J	0.090 J

Standard Strokes

Bore size	Standard stroke (mm)	Maximum manufacturable stroke (mm)
10	15, 30, 45, 60, 75, 100, 125, 150	400
16	15, 30, 45, 60, 75, 100, 125, 150, 175, 200	400

- * Manufacture of intermediate strokes at 1 mm intervals is possible. (Spacers are not used.)
- * Applicable strokes should be confirmed according to the usage. For details, refer to "Air Cylinders Model Selection" on front matter pages of the Best Pneumatics No. 2 or the **WEB catalog**. In addition, the products that exceed the standard stroke might not be able to fulfill the specifications due to the deflection etc.

Accessories

(For details, refer to page 376.)

Standard	Rod end nut
Option**	Single knuckle joint, Double knuckle joint*, Rod end cap (Flat/Round type)

- * A knuckle pin and retaining rings are shipped together with double knuckle joint.
- ** Can be ordered within the cylinder model.

Weights

Bore size (mm)		10	16
Basic weight	Basic	36	61
	(When the stroke is zero) Axial piping	36	61
Additional weight per 15 mm of stroke		4	7
Accessories	Single knuckle joint	17	23
	Double knuckle joint (including knuckle pin)	25	21
	Rod end cap (Flat type)	1	2
	Rod end cap (Round type)	1	2

* Mounting nut and rod end nut are included in the basic weight.

Calculation:

Example) **CJ2RA10-45Z**

- Basic weight 36 (ø10)
 - Additional weight 4/15 stroke
 - Cylinder stroke 45 stroke
- 36 + 4/15 x 45 = **48 g**

Refer to pages 453 to 460 for cylinders with auto switches.

- Auto switch proper mounting position (detection at stroke end) and its mounting height
- Minimum stroke for auto switch mounting
- Operating range
- Auto switch mounting brackets/Part no.

Clean Series

10-CJ2RA Bore size - Stroke Head cover port location Z
 ↓ Clean Series

Air cylinder which is applicable for the system which discharges leakage from the rod section directly into the outside of clean room by relief port and making an actuator's rod section having a double seal construction.

For the detailed specifications, refer to the "Pneumatic Clean Series" (WEB catalog).

Specifications

Action	Double acting, Single rod
Bore size (mm)	10, 16
Maximum operating pressure	0.7 MPa
Minimum operating pressure	0.08 MPa
Cushion	Rubber bumper
Standard stroke (mm)	Same as standard type. (Refer to page 431.)
Auto switch	Mountable (Band mounting type)
Mounting	Bottom mounting style

10-CJ2RA (Clean Series) Construction (Not able to disassemble)

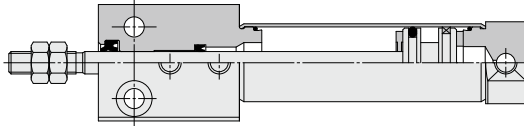

Air Cylinders

CJ2

CM2

CG1

MB

CA2

CQ2

CQS

Lube-retainer

JA

MXH

MXQ

MGP

C□Y

C□X

CK□1

C(L)□

C(L)□U

CKQ

CKZ2N

WRF

INDEX

Series CJ2R

Construction (Not able to disassemble)

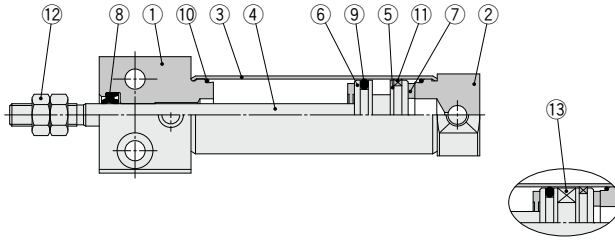

CDJ2RA10/16-□Z-B

Component Parts

No.	Description	Material	Note
1	Rod cover	Aluminum alloy	Clear hard anodized
2	Head cover	Aluminum alloy	Clear hard anodized
3	Cylinder tube	Stainless steel	
4	Piston rod	Stainless steel	
5	Piston A	Aluminum alloy	
6	Piston B	Aluminum alloy	
7	Bumper	Urethane	

No.	Description	Material	Note
8	Rod seal	NBR	
9	Piston seal	NBR	
10	Tube gasket	NBR	
11	Wear ring	Resin	
12	Rod end nut	Rolled steel	Zinc chromated
13	Magnet	—	

Bottom Mounting Style

CJ2RA – Z

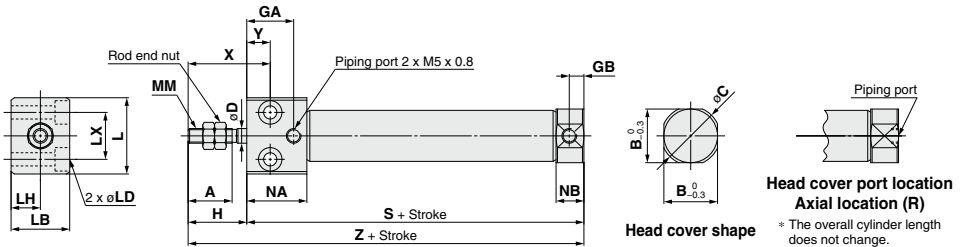

Head cover port location
Axial location (R)

* The overall cylinder length does not change.

Bore size	(mm)																		
	A	B	C	D	GA	GB	H	L	LB	LD	LH	LX	MM	NA	NB	X	Y	S	Z
10	15	12	14	4	16	5	20	23	16	ø3.5 through, ø6.5 counterbore depth 4	8	12	M4 x 0.7	20.5	9.5	28	8	54	74
16	15	18.3	20	5	16	5	20	26	20	ø4.5 through, ø8 counterbore depth 5	10	16	M5 x 0.8	20.5	9.5	28	8	55	75

Air Cylinder: Direct Mount Type Single Acting, Spring Return/Extend

Series CJ2R

ø10, ø16

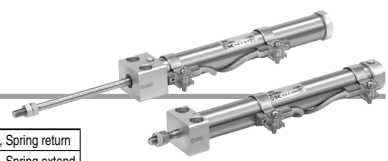

How to Order

Cylinder standard stroke (mm)
Refer to "Standard Strokes" on page 435.

Action
S Single acting, Spring return
T Single acting, Spring extend

CJ2RA 16 - 45 S [] Z - [] - []

With auto switch CDJ2RA 16 - 45 S [] Z - [] - M9BW [] - B - []

With auto switch
(Built-in magnet)

Mounting
A Bottom mounting style

Bore size
10 10 mm
16 16 mm

Head cover port location

Nil	Perpendicular to axis	
R	Axial	

* Not applicable to single acting, spring extend (T).

Auto switch
 * For applicable auto switches, refer to the table below.
 * If a built-in magnet cylinder without an auto switch is required, refer to the model of built-in magnet cylinder.

Rod end bracket

Nil	None
V	Single knuckle joint
W	Double knuckle joint
T	Rod end cap (Flat type)
U	Rod end cap (Round type)

* Rod end bracket is shipped together with the product, but not assembled.
 * A knuckle joint pin is not provided with the single knuckle joint.

Made to Order
Refer to page 435 for details.

Auto switch mounting type
A Rail mounting
B Band mounting

* For rail mounting, screws and nuts for 2 auto switches come with the rail.
 * Refer to page 459 for auto switch mounting brackets.

Number of auto switches

Nil	2 pcs.
S	1 pc.
n	"n" pcs.

* Refer to "Ordering Example of Cylinder Assembly" on page 435.

Applicable Auto Switches

Refer to the WEB catalog or the Best Pneumatics No. 2 for further information on auto switches.

Type	Special function	Electrical entry	Indicating light	Wiring (Output)	Load voltage		Auto switch model				Lead wire length (m)					Pre-wired connector	Applicable load			
					DC	AC	Band mounting		Rail mounting		0.5 (Nil)	1 (M)	3 (L)	5 (Z)	None (N)					
							Perpendicular	In-line	Perpendicular	In-line										
Solid state auto switch	—	Grommet	No	3-wire (NPN)	5 V, 12 V	—	M9NV	M9N	M9NV	M9N	●	●	●	○	○	IC circuit	—			
				3-wire (PNP)			M9PV	M9P	M9PV	M9P	●	●	●	○	○					
		Connector		2-wire	M9BV	M9B	M9BV	M9B	●	●	●	○	○							
				—	H7C	J79C	—	—	●	—	●	—	—							
	Diagnostic indication (2-color indication)	Grommet	Yes	3-wire (NPN)	5 V, 12 V	—	M9NVV	M9NW	M9NVV	M9NW	●	●	●	○	○	IC circuit	Relay, PLC			
				3-wire (PNP)			M9PWW	M9PW	M9PWW	M9PW	●	●	●	○	○					
	Water resistant (2-color indication)	Grommet		2-wire	12 V	—	M9BWW	M9BW	M9BWW	M9BW	●	●	●	○	○					
				3-wire (NPN)	5 V, 12 V	—	M9NAV**	M9NA**	M9NAV**	M9NA**	○	○	●	—	—	IC circuit				
	With diagnostic output (2-color indication)	Grommet	No	3-wire (PNP)	12 V	—	M9PAV**	M9PA**	M9PAV**	M9PA**	○	○	●	—	—		IC circuit			
				2-wire			M9BAV**	M9BA**	M9BAV**	M9BA**	○	○	○	—	—					
—				Grommet	Yes	4-wire (NPN)	5 V, 12 V	—	—	H7NF	—	F79F	●	—	○	○	IC circuit			
						3-wire (NPN equivalent)			5 V	—	A96V	A96	A96V	A96	●	—		●	—	IC circuit
Reed auto switch	—	Grommet	No	2-wire	24 V	12 V	—	—	A72	A72H	●	—	●	—	IC circuit	Relay, PLC				
							—	—	A93V	A93	A93V	A93	●	—			●	—		
		Connector					100 V or less	A90V	A90	A90V	A90	●	—	●	—	IC circuit				
							24 V or less	—	C73C	A73C	—	●	—	●	—					
		Diagnostic indication (2-color indication)					Grommet	Yes	—	—	—	—	C80C	A80C	—	—	●	—	●	IC circuit
									—	—	—	A79W	—	—	●	—	●	—		

** Water resistant type auto switches can be mounted on the above models, but in such case SMC cannot guarantee water resistance.
 Please contact SMC regarding water resistant types with the above model numbers.
 * Lead wire length symbols: 0.5 m..... Nil (Example) M9NV
 1 m..... M (Example) M9NWM
 3 m..... L (Example) M9NWL
 5 m..... Z (Example) M9NWZ
 None..... N (Example) H7CN
 * Since there are other applicable auto switches than listed, refer to page 460 for details.
 * For details about auto switches with pre-wired connector, refer to the WEB catalog or the Best Pneumatics No. 2.
 * Solid state auto switches marked with "O" are produced upon receipt of order.
 * The D-A90C/M90C/A70C/A80C/F70C/J70C auto switches are shipped together, (but not assembled). (For band mounting, only auto switch mounting brackets are assembled before being shipped.)



Air Cylinders

CJ2
CM2
CG1
MB
CA2
CQ2
CQS
Lube-retainer
JA
MXH
MXQ
MGP
CX1
CX
CK1
CL1
CLJKU
CKQ
CKZ2N
WRF
INDEX

Series CJ2R

The CJ2R direct mount cylinder can be installed directly through the use of a square rod cover.



Symbol

Single acting, Spring return, Rubber bumper
Single acting, Spring extend, Rubber bumper



Made to Order

(For details, refer to pages 463 to 472.)

Symbol	Specifications
-XA□	Change of rod end shape
-XC51	With hose nipple
-XC85	Grease for food processing equipment
-X446	PTFE grease

⚠ Precautions

Refer to page 473 before handling.

Ordering Example of Cylinder Assembly

Cylinder model: CDJ2RA16-45SZ-W-M9BW-B

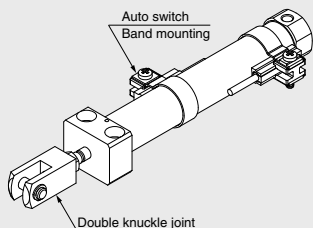

Mounting A: Bottom mounting style
Rod end bracket W: Double knuckle joint
Auto switch D-M9BW: 2 pcs.
Auto switch mounting B: Band mounting

* Double knuckle joint and auto switch are shipped together with the product, but not assembled.

Specifications

Bore size (mm)	10	16
Action	Single acting, Spring return/Single acting, Spring extend	
Fluid	Air	
Proof pressure	1 MPa	
Maximum operating pressure	0.7 MPa	
Minimum operating pressure	0.15 MPa	
Ambient and fluid temperature	Without auto switch: -10°C to 70°C (No freezing) With auto switch: -10°C to 60°C	
Cushion	Rubber bumper	
Lubrication	Not required (Non-lube)	
Stroke length tolerance	+1.0 0	
Piston speed	50 to 750 mm/s	
Allowable kinetic energy	0.035 J	0.090 J

Standard Strokes

Bore size	Standard stroke (mm)
10	15, 30, 45, 60
16	15, 30, 45, 60, 75, 100, 125, 150

* Manufacture of intermediate strokes at 1 mm intervals is possible. (Spacers are not used.)

* Please consult with SMC for strokes which exceed the standard stroke length.

* Applicable strokes should be confirmed according to the usage. For details, refer to "Air Cylinders Model Selection" on front matter pages of the Best Pneumatics No. 2 or the WEB catalog. In addition, the products that exceed the standard stroke might not be able to fulfill the specifications due to the deflection etc.

Accessories /For details, refer to page 376.

Standard	Rod end nut
Option**	Single knuckle joint, Double knuckle joint*, Rod end cap (Flat type, Round type)

* A knuckle pin and retaining rings are shipped together with double knuckle joint.

** Can be ordered within the cylinder model.

Spring Reaction Force

Bore size (mm)	Spring reaction force (N)	
	Primary	Secondary
10	3.53	6.86
16	6.86	14.2

Spring with primary mounting load

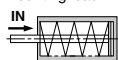

When the spring is set in the cylinder

Spring with secondary mounting load

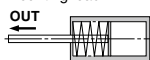

When the spring is contracted by applying air

Refer to pages 453 to 460 for cylinders with auto switches.

- Auto switch proper mounting position (detection at stroke end) and its mounting height
- Minimum stroke for auto switch mounting
- Operating range
- Auto switch mounting brackets/Part no.

Weights

Spring Return (g)

Bore size (mm)		10		16	
Basic weight	Mounting	Basic	Axial	Basic	Axial
		15 stroke	42	42	81
	30 stroke	49	49	97	97
	45 stroke	59	59	114	114
	60 stroke	68	68	132	132
	75 stroke			154	154
	100 stroke			187	187
	125 stroke			224	224
	150 stroke			246	246
Accessories	Single knuckle joint	17		23	
	Double knuckle joint (including knuckle pin)	25		21	
	Rod end cap (Flat type)	1		2	
	Rod end cap (Round type)	1		2	

* Rod end nut is included in the basic weight.

Spring Extend (g)

Bore size (mm)		10		16	
Basic weight	Mounting	Basic		Basic	
		15 stroke	41		78
	30 stroke	47		92	
	45 stroke	55		108	
	60 stroke	64		123	
	75 stroke			144	
	100 stroke			173	
	125 stroke			208	
	150 stroke			228	
Accessories	Single knuckle joint	17		23	
	Double knuckle joint (including knuckle pin)	25		21	
	Rod end cap (Flat type)	1		2	
	Rod end cap (Round type)	1		2	

Construction (Not able to disassemble)

CJ2RA□-□SZ

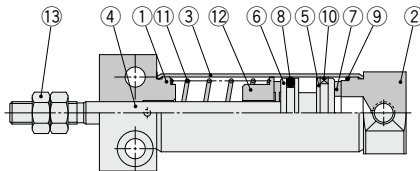

CDJ2RA10/16-□SZ-B

CJ2RA□-□TZ

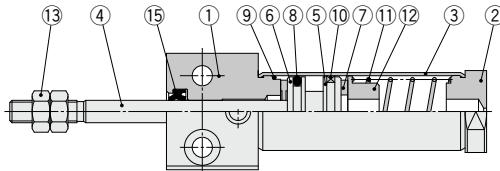

CDJ2RA10/16-□TZ-B

Component Parts

No.	Description	Material	Note
1	Rod cover	Aluminum alloy	Clear hard anodized
2	Head cover	Aluminum alloy	Clear hard anodized
3	Cylinder tube	Stainless steel	
4	Piston rod	Stainless steel	
5	Piston A	Aluminum alloy	
6	Piston B	Aluminum alloy	
7	Bumper	Urethane	
8	Piston seal	NBR	

No.	Description	Material	Note
9	Tube gasket	NBR	
10	Wear ring	Resin	
11	Return spring	Piano wire	Zinc chromated
12	Spring seat	Aluminum alloy	
13	Rod end nut	Rolled steel	Zinc chromated
14	Magnet	—	
15	Rod seal	NBR	

Series CJ2R

Single Acting: Bottom Mounting Style

Spring return: CJ2RA **Bore size** – **Stroke** **S** | **Head cover port location** **Z**

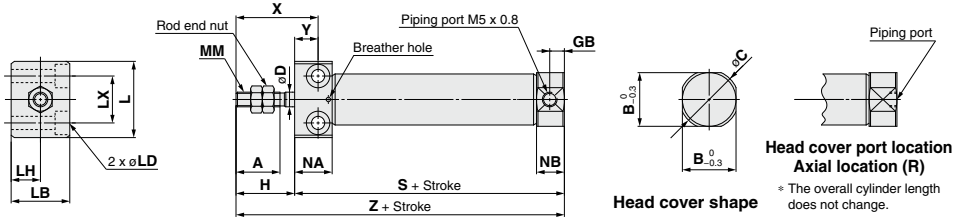

Bore size	A	B	C	D	GB	H	L	LB	LD	LH	LX	MM	NA	NB	X	Y
10	15	12	14	4	5	20	23	16	ø3.5 through, ø6.5 counterbore depth 4	8	12	M4 x 0.7	12.8	9.5	28	8
16	15	18.3	20	5	5	20	26	20	ø4.5 through, ø8 counterbore depth 5	10	16	M5 x 0.8	12.8	9.5	28	8

Dimensions by Stroke: Spring Return

Bore size	S								Z							
	5 to 15 st	16 to 30 st	31 to 45 st	46 to 60 st	61 to 75 st	76 to 100 st	101 to 125 st	126 to 150 st	5 to 15 st	16 to 30 st	31 to 45 st	46 to 60 st	61 to 75 st	76 to 100 st	101 to 125 st	126 to 150 st
10	53.5	61	73	85	—	—	—	—	73.5	81	93	105	—	—	—	—
16	53.5	62	74	86	92	116	134	146	73.5	82	94	106	112	136	154	166

Spring extend: CJ2RA **Bore size** – **Stroke** **TZ**

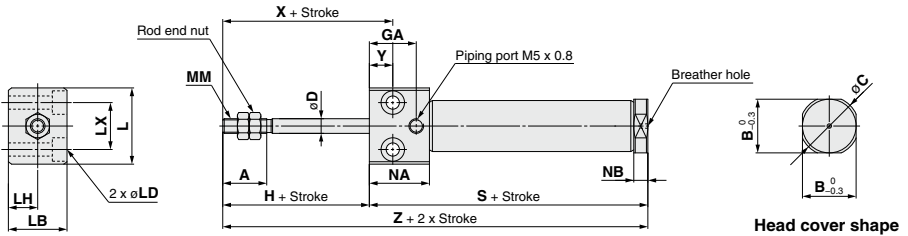

Bore size	A	B	C	D	GA	H	L	LB	LD	LH	LX	MM	NA	NB	X	Y
10	15	12	14	4	16	20	23	16	ø3.5 through, ø6.5 counterbore depth 4	8	12	M4 x 0.7	20.5	4.8	28	8
16	15	18.3	20	5	16	20	26	20	ø4.5 through, ø8 counterbore depth 5	10	16	M5 x 0.8	20.5	4.8	28	8

Dimensions by Stroke: Spring Extend

Bore size	S								Z							
	5 to 15 st	16 to 30 st	31 to 45 st	46 to 60 st	61 to 75 st	76 to 100 st	101 to 125 st	126 to 150 st	5 to 15 st	16 to 30 st	31 to 45 st	46 to 60 st	61 to 75 st	76 to 100 st	101 to 125 st	126 to 150 st
10	56.5	64	76	88	—	—	—	—	76.5	84	96	108	—	—	—	—
16	56.5	65	77	89	95	119	137	149	76.5	85	97	109	115	139	157	169

Air Cylinder: Direct Mount, Non-rotating Rod Type Double Acting, Single Rod

Series **CJ2RK** ø10, ø16



How to Order

Cylinder standard stroke (mm)
Refer to "Standard Strokes" on page 439.

CJ2RKA 16 - 60 [] Z - [] - []

With auto switch

CDJ2RKA 16 - 60 [] Z - [] - **M9BW** [] - **B** - []

With auto switch
(Built-in magnet)

Mounting

A Bottom mounting style

Bore size

10	10 mm
16	16 mm

Head cover port location

Nil	Perpendicular to axis	
	R	Axial

Auto switch

* For applicable auto switches, refer to the table below.

* If a built-in magnet cylinder without an auto switch is required, refer to the model of built-in magnet cylinder.

Rod end bracket

Nil	None
V	Single knuckle joint
W	Double knuckle joint
T	Rod end cap (Flat type)
U	Rod end cap (Round type)

* Rod end bracket is shipped together with the product, but not assembled.

* A knuckle joint pin is not provided with the single knuckle joint.

Made to Order

Refer to page 439 for details.

Auto switch mounting type

A Rail mounting
B Band mounting

* For rail mounting, screws and nuts for 2 auto switches come with the rail.

* Refer to page 459 for auto switch mounting brackets.

Number of auto switches

Nil	2 pcs.
S	1 pc.
n	"n" pcs.

* Refer to "Ordering Example of Cylinder Assembly" on page 439.

Applicable Auto Switches/Refer to the WEB catalog or the Best Pneumatics No. 2 for further information on auto switches.

Type	Special function	Electrical entry	Indicator light	Wiring (Output)	Load voltage		Auto switch model				Lead wire length (m)					Pre-wired connector	Applicable load
					DC	AC	Band mounting		Rail mounting		0.5 (Nil)	1 (M)	3 (L)	5 (Z)	None (N)		
							In-line	Perpendicular	In-line	Perpendicular							
Solid state auto switch	—	Grommet	—	3-wire (NPN)	5 V, 12 V	—	M9NV	M9N	M9NV	M9N	●	●	○	○	○	IC circuit	Relay, PLC
				3-wire (PNP)			M9PV	M9P	M9PV	M9P	●	●	○	○	○		
		Connector	2-wire	M9BV	M9B	M9BV	M9B	●	●	○	○	○	—				
			—	H7C	J79C	—	●	●	○	○	○						
	Diagnostic indication (2-color indication)	Grommet	Yes	3-wire (NPN)	5 V, 12 V	—	M9NWV	M9NW	M9NWV	M9NW	●	●	○	○	○	IC circuit	Relay, PLC
				3-wire (PNP)			M9PWV	M9PW	M9PWV	M9PW	●	●	○	○	○		
	Water resistant (2-color indication)	Grommet	—	3-wire (NPN)	5 V, 12 V	—	M9B WV	M9B W	M9B WV	M9B W	●	●	○	○	○	—	—
				3-wire (PNP)			M9NAV**	M9NA**	M9NAV**	M9NA**	○	○	○	○	○		
	With diagnostic output (2-color indication)	Grommet	—	3-wire (NPN)	5 V, 12 V	—	M9PAV**	M9PA**	M9PAV**	M9PA**	○	○	○	○	○	IC circuit	—
				2-wire			M9BAV**	M9BA**	M9BAV**	M9BA**	○	○	○	○	○		
Reed auto switch	—	Grommet	Yes	3-wire (NPN equivalent)	5 V	—	A96V	A96	A96V	A96	●	●	—	—	—	IC circuit	—
				—			—	—	A72	A72H	●	—	—	—	—		
		Connector	2-wire	12 V	100 V or less	A93V	A93	A93V	A93	●	—	●	—	—	—	IC circuit	
			—	—	24 V or less	A90V	A90	A90V	A90	●	—	●	—	—			
	Diagnostic indication (2-color indication)	Grommet	Yes	—	—	—	—	C73C	A73C	—	●	—	●	●	●	IC circuit	Relay, PLC
				—	—	—	—	C80C	A80C	—	●	—	●	●	●		
	—	Grommet	No	—	—	—	—	A79W	—	—	●	—	●	—	—	—	—
				—	—	—	—	—	—	—	—	●	—	●	—		

** Water resistant type auto switches can be mounted on the above models, but in such case SMC cannot guarantee water resistance. Please contact SMC regarding water resistant types with the above model numbers.

* Lead wire length symbols: 0.5 m..... Nil (Example) M9NW
1 m..... M (Example) M9NWM
3 m..... L (Example) M9NWL
5 m..... Z (Example) M9NWZ
None..... N (Example) H7CN

* Since there are other applicable auto switches than listed, refer to page 460 for details.
* For details about auto switches with pre-wired connector, refer to the WEB catalog or the Best Pneumatics No. 2.

* Solid state auto switches marked with "O" are produced upon receipt of order.

* The D-A90C/M90C/A70C/A80C/F70C/J70C auto switches are shipped together, (but not assembled). (For band mounting, only auto switch mounting brackets are assembled before being shipped.)



Air Cylinders

CJ2

CM2

CG1

MB

CA2

CQ2

CQS

Lube-retainer

JA

MXH

MXQ

MGP

CY

CX

CK1

CLK

CLKU

CKQ

CKZN

WRF

INDEX

Series CJ2RK

A cylinder which rod does not rotate because of the hexagonal rod shape.

Non-rotating accuracy

ø10: ±1.5°, ø16: ±1°

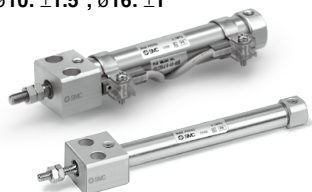

Symbol

Double acting, Single rod, Rubber bumper



Made to Order

(For details, refer to pages 463 to 472.)

Symbol	Specifications
-XA□	Change of rod end shape
-XC9	Adjustable stroke cylinder/Adjustable retraction type
-XC51	With hose nipple
-XC85	Grease for food processing equipment
-X446	PTFE grease

Precautions

Refer to page 473 before handling.

Ordering Example of Cylinder Assembly

Cylinder model: CDJ2RKA16-60Z-W-M9BW-B

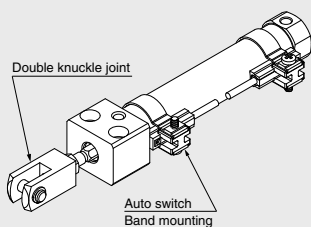

Mounting A: Bottom mounting style
Rod end bracket W: Double knuckle joint
Auto switch D-M9BW: 2 pcs.
Auto switch mounting B: Band mounting

* Double knuckle joint and auto switch are shipped together with the product, but not assembled.

Specifications

Bore size (mm)	10	16
Action	Double acting, Single rod	
Fluid	Air	
Proof pressure	1 MPa	
Maximum operating pressure	0.7 MPa	
Minimum operating pressure	0.06 MPa	
Ambient and fluid temperature	Without auto switch: -10°C to 70°C With auto switch: -10°C to 60°C (No freezing)	
Cushion	Rubber bumper	
Lubrication	Not required (Non-lube)	
Stroke length tolerance	±0.10	
Rod non-rotating accuracy	±1.5°	±1°
Piston speed	50 to 750 mm/s	
Allowable kinetic energy	0.035 J	0.090 J

Standard Strokes

Bore size	Standard stroke (mm)
10	15, 30, 45, 60, 75, 100, 125, 150
16	15, 30, 45, 60, 75, 100, 125, 150, 175, 200

- * Manufacture of intermediate strokes at 1 mm intervals is possible. (Spacers are not used.)
- * Please consult with SMC for strokes which exceed the standard stroke length.
- * Applicable strokes should be confirmed according to the usage. For details, refer to "Air Cylinders Model Selection" on front matter pages of the Best Pneumatics No. 2 or the **WEB catalog**. In addition, the products that exceed the standard stroke might not be able to fulfill the specifications due to the deflection etc.

Accessories

(For details, refer to page 376.)

Standard	Rod end nut
Option**	Single knuckle joint, Double knuckle joint*, Rod end cap (Flat/Round type)

* A knuckle pin and retaining rings are shipped together with double knuckle joint.

** Can be ordered within the cylinder model.

Weights

Bore size (mm)	10	16	
Basic weight	Basic	36	62
	Axial piping	36	62
Additional weight per 15 mm of stroke	Basic	4	7
	Accessories	17	23
Accessories	Single knuckle joint	17	23
	Double knuckle joint (including knuckle pin)	25	21
	Rod end cap (Flat type)	1	2
	Rod end cap (Round type)	1	2

* Rod end nut is included in the basic weight.

Calculation:

Example) **CJ2RKA10-45Z**

- Basic weight 36 (ø10)
 - Additional weight 4/15 stroke
 - Cylinder stroke 45 stroke
- $$36 + 4/15 \times 45 = 48 \text{ g}$$

Refer to pages 453 to 460 for cylinders with auto switches.

- Auto switch proper mounting position (detection at stroke end) and its mounting height
- Minimum stroke for auto switch mounting
- Operating range
- Auto switch mounting brackets/Part no.

Air Cylinder: Direct Mount, Non-rotating Rod Type Series **CJ2RK**

Double Acting, Single Rod

Construction (Not able to disassemble)

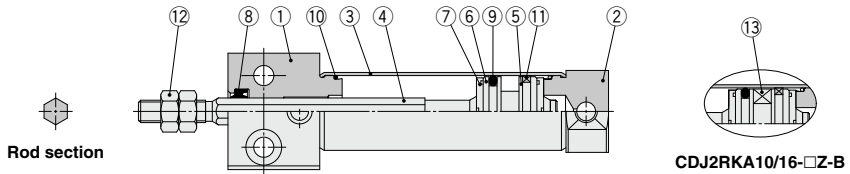

Component Parts

No.	Description	Material	Note
1	Rod cover	Aluminum alloy	Clear hard anodized
2	Head cover	Aluminum alloy	Clear hard anodized
3	Cylinder tube	Stainless steel	
4	Piston rod	Stainless steel	
5	Piston A	Aluminum alloy	
6	Piston B	Aluminum alloy	
7	Bumper	Urethane	

No.	Description	Material	Note
8	Rod seal	NBR	
9	Piston seal	NBR	
10	Tube gasket	NBR	
11	Wear ring	Resin	
12	Rod end nut	Rolled steel	Zinc chromated
13	Magnet	—	

Bottom Mounting Style

CJ2RKA Bore size – Stroke Head cover port location **Z**

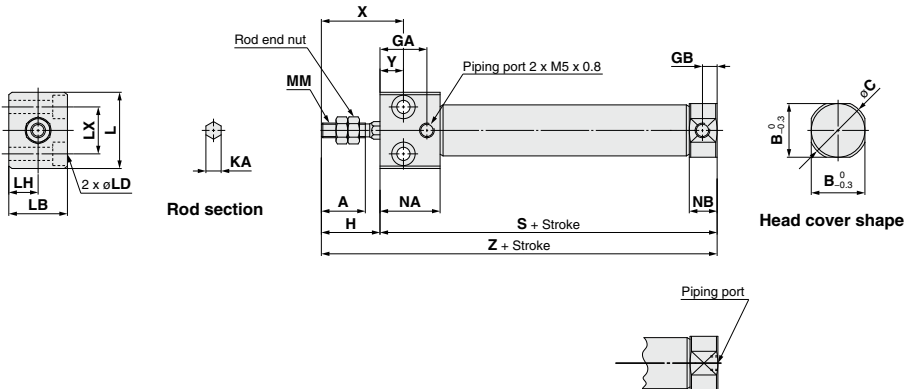

* The overall cylinder length does not change.

Bore size	A	B	C	GA	GB	H	KA	L	LB	LD	LH	LX	MM	NA	NB	X	Y	S	Z
10	15	12	14	16	5	20	4.2	23	16	ø3.5 through, ø6.5 counterbore depth 4	8	12	M4 x 0.7	20.5	9.5	28	8	54	74
16	15	18.3	20	16	5	20	5.2	26	20	ø4.5 through, ø8 counterbore depth 5	10	16	M5 x 0.8	20.5	9.5	28	8	55	75

Air Cylinders

CJ2

CM2

CG1

MB

CA2

CQ2

CQS

Lube-retainer

JA

MXH

MXQ

MGP

Y

X

CK□1

CL□□

CL□KU

CKQ

CKZZN

WRF

INDEX

Air Cylinder: Direct Mount, Non-rotating Rod Type Single Acting, Spring Return/Extend

Series CJ2RK



ø10, ø16

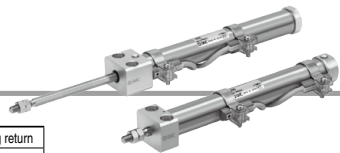

How to Order

Cylinder standard stroke (mm)
Refer to "Standard Strokes" on page 442.

Action

S	Single acting, Spring return
T	Single acting, Spring extend

CJ2RKA 16-45 S [] **Z** [] [] []

With auto switch CDJ2RKA 16-45 S [] **Z** [] [] [] **M9BW** [] **B** [] []

With auto switch
(Built-in magnet)

Mounting

A	Bottom mounting style
----------	-----------------------

Bore size

10	10 mm
16	16 mm

Head cover port location

NII	Perpendicular to axis	
R	Axial	

* Not applicable to single acting, spring extend (T).

Auto switch

* For applicable auto switches, refer to the table below.

★ If a built-in magnet cylinder without an auto switch is required, refer to the model of built-in magnet cylinder.

Rod end bracket

Nil	None
V	Single knuckle joint
W	Double knuckle joint
T	Rod end cap (Flat type)
U	Rod end cap (Round type)

* Rod end bracket is shipped together with the product, but not assembled.

* A knuckle joint pin is not provided with the single knuckle joint.

Made to Order
Refer to page 442 for details.

Auto switch mounting type

A	Rail mounting
B	Band mounting

* For rail mounting, screws and nuts for 2 auto switches come with the rail.

* Refer to page 459 for auto switch mounting brackets.

Number of auto switches

Nil	2 pcs.
S	1 pc.
n	"n" pcs.

* Refer to "Ordering Example of Cylinder Assembly" on page 442.

Applicable Auto Switches

Refer to the **WEB catalog** or the Best Pneumatics No. 2 for further information on auto switches.

Type	Special function	Electrical entry	Indicating light	Wiring (Output)	Load voltage		Auto switch model				Lead wire length (m)					Pre-wired connector	Applicable load						
					DC	AC	Band mounting		Rail mounting		0.5 (Nil)	1 (M)	3 (Z)	5 (L)	None (N)								
							Perpendicular	In-line	Perpendicular	In-line													
Solid state auto switch	—	Grommet	No	3-wire (NPN)	5 V, 12 V	—	M9NV	M9N	M9NV	M9N	●	●	●	○	○	IC circuit	Relay, PLC						
				3-wire (PNP)			M9PV	M9P	M9PV	M9P	●	●	●	○	○								
	Connector	Yes	2-wire	12 V	—	M9BV	M9B	M9BV	M9B	●	●	●	○	○	—								
			—	—	H7C	J79C	—	●	●	●	●	—	—										
	Diagnostic indication (2-color indication)	Grommet	Yes	3-wire (NPN)	5 V, 12 V	—	M9NVV	M9NW	M9NVV	M9NW	●	●	●	○	○	IC circuit							
				3-wire (PNP)			M9PVV	M9PW	M9PVV	M9PW	●	●	●	○	○								
	Water resistant (2-color indication)	Grommet	No	3-wire (NPN)	5 V, 12 V	—	M9BWW	M9BW	M9BWW	M9BW	●	●	●	○	○	IC circuit							
3-wire (PNP)				M9NAV**			M9NA**	M9NAV**	M9NA**	○	○	○	○	○									
With diagnostic output (2-color indication)	Grommet	Yes	2-wire	12 V	—	M9PAV**	M9PA**	M9PAV**	M9PA**	○	○	○	○	○	IC circuit								
			4-wire (NPN)	5 V, 12 V	—	M9BAV**	M9BA**	M9BAV**	M9BA**	○	○	○	○										
Reed auto switch	—	Grommet	No	3-wire (NPN equivalent)	5 V	—	A96V	A96	A96V	A96	●	●	—	—	—	IC circuit	—						
				2-wire			—	—	A72	A72H	●	●	—	—	—								
							—	200 V	—	—	—	—	—	—	—			—					
							—	100 V	A93V	A93	A93V	A93	●	●	●			●	—				
				Connector			No	Yes	2-wire	24 V	12 V	100 V or less	A90V	A90	A90V			A90	●	●	●	●	IC circuit
												—	—	C73C	A73C			—	●	●	●	●	
				Diagnostic indication (2-color indication)			Grommet	Yes	No	2-wire	24 V or less	—	C80C	A80C	—			—	●	●	●	●	IC circuit
—	—	A79V	—		—	●						●	●	●	—								

** Water resistant type auto switches can be mounted on the above models, but in such case SMC cannot guarantee water resistance.

Please contact SMC regarding water resistant types with the above model numbers.

* Lead wire length symbols: 0.5 m..... Nil (Example) M9NV
1 m..... M (Example) M9NW
3 m..... L (Example) M9NWL
5 m..... N (Example) M9NWZ
None..... N (Example) H7CN

* Since there are other applicable auto switches than listed, refer to page 460 for details.

* For details about auto switches with pre-wired connector, refer to the **WEB catalog** or the Best Pneumatics No. 2.

* Solid state auto switches marked with "O" are produced upon receipt of order.

* The D-A90□/M9□□□/A7□□/A8□□/F7□□□□□ auto switches are shipped together, (but not assembled). (For band mounting, only auto switch mounting brackets are assembled before being shipped.)

Air Cylinder: Direct Mount, Non-rotating Rod Type Single Acting, Spring Return/Extend **Series CJ2RK**

A cylinder which rod does not rotate because of the hexagonal rod shape.

Non-rotating accuracy
 $\phi 10: \pm 1.5^\circ$, $\phi 16: \pm 1^\circ$
Can operate without lubrication.

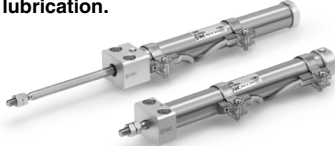

Symbol

Single acting, Spring return, Rubber bumper Single acting, Spring extend, Rubber bumper



Made to Order
 (For details, refer to pages 463 to 472.)

Symbol	Specifications
-XA□	Change of rod end shape
-XC51	With hose nipple
-XC85	Grease for food processing equipment
-X446	PTFE grease

⚠ Precautions

Refer to page 473 before handling.

Ordering Example of Cylinder Assembly

Cylinder model: CDJ2RKA16-45SZ-W-M9BW-B

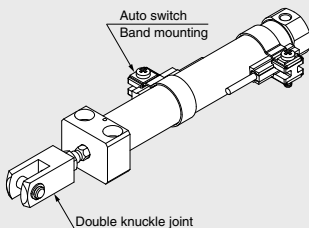

Mounting **A: Bottom mounting style**
Rod end bracket W: Double knuckle joint
Auto switch D-M9BW: 2 pcs.
Auto switch mounting B: Band mounting

* Double knuckle joint and auto switch are shipped together with the product, but not assembled.

Specifications

Bore size (mm)	10	16
Action	Single acting, Spring return/Single acting, Spring extend	
Fluid	Air	
Proof pressure	1 MPa	
Maximum operating pressure	0.7 MPa	
Minimum operating pressure	0.15 MPa	
Ambient and fluid temperature	Without auto switch: -10°C to 70°C With auto switch: -10°C to 60°C (No freezing)	
Cushion	Rubber bumper	
Lubrication	Not required (Non-lube)	
Stroke length tolerance	$^{+1.0}_0$	
Rod non-rotating accuracy	$\pm 1.5^\circ$	$\pm 1^\circ$
Piston speed	50 to 750 mm/s	
Allowable kinetic energy	0.035 J	0.090 J

Standard Strokes

Bore size (mm)	Standard stroke (mm)
10	15, 30, 45, 60
16	15, 30, 45, 60, 75, 100, 125, 150

- * Manufacture of intermediate strokes at 1 mm intervals is possible. (Spacers are not used.)
- * Please consult with SMC for strokes which exceed the standard stroke length.
- * Applicable strokes should be confirmed according to the usage. For details, refer to "Air Cylinders Model Selection" on front matter pages of the Best Pneumatics No. 2 or the **WEB catalog**. In addition, the products that exceed the standard stroke might not be able to fulfill the specifications due to the deflection etc.

Accessories

(For details, refer to page 376.)

Standard	Rod end nut
Option**	Single knuckle joint, Double knuckle joint*, Rod end cap (Flat/Round type)

- * A knuckle pin and retaining rings are shipped together with double knuckle joint.
- ** Can be ordered within the cylinder model.

Spring Reaction Force

Bore size (mm)	Spring reaction force (N)	
	Primary	Secondary
10	3.53	6.86
16	6.86	14.2

Spring with primary mounting load

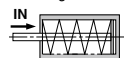

When the spring is set in the cylinder

Spring with secondary mounting load

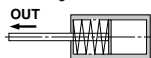

When the spring is contracted by applying air

Refer to pages 453 to 460 for cylinders with auto switches.

- Auto switch proper mounting position (detection at stroke end) and its mounting height
- Minimum stroke for auto switch mounting
- Operating range
- Auto switch mounting brackets/Part no.

Air Cylinders

CJ2

CM2

CG1

MB

CA2

CQ2

CQS

JA

MXH

MXQ

MGP

CY

CX

CK1

CLJK

CLJU

CKQ

CKZZN

WRF

INDEX

Series CJ2RK

Weights

Spring Return

(g)

Bore size (mm)		10		16	
Mounting		Basic	Axial	Basic	Axial
Basic weight	15 stroke	44	44	83	83
	30 stroke	52	52	99	99
	45 stroke	62	62	117	117
	60 stroke	72	72	135	135
	75 stroke			157	157
	100 stroke			191	191
	125 stroke			228	228
	150 stroke			251	251
Accessories	Single knuckle joint	17		23	
	Double knuckle joint (including knuckle pin)	25		21	
	Rod end cap (Flat type)	1		2	
	Rod end cap (Round type)	1		2	

* Rod end nut is included in the basic weight.

Spring Extend

(g)

Bore size (mm)		10	16
Mounting		Basic	Basic
Basic weight	15 stroke	42	79
	30 stroke	48	93
	45 stroke	57	110
	60 stroke	66	126
	75 stroke		147
	100 stroke		177
	125 stroke		213
	150 stroke		234
Accessories	Single knuckle joint	17	23
	Double knuckle joint (including knuckle pin)	25	21
	Rod end cap (Flat type)	1	2
	Rod end cap (Round type)	1	2

Construction (Not able to disassemble)

Single acting, Spring return

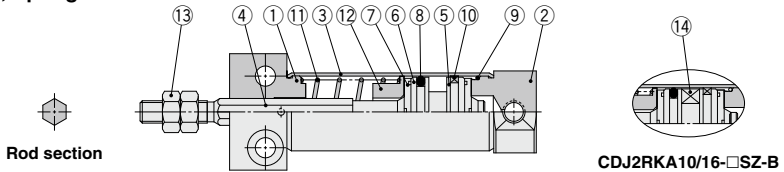

Single acting, Spring extend

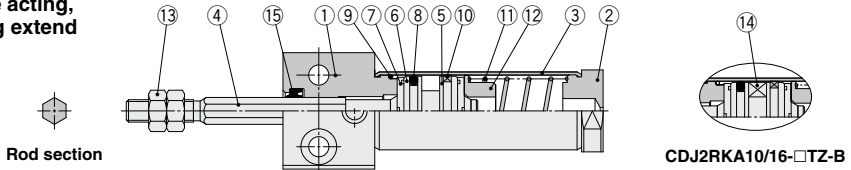

Component Parts

No.	Description	Material	Note
1	Rod cover	Aluminum alloy	Clear hard anodized
2	Head cover	Aluminum alloy	Clear hard anodized
3	Cylinder tube	Stainless steel	
4	Piston rod	Stainless steel	
5	Piston A	Aluminum alloy	
6	Piston B	Aluminum alloy	
7	Bumper	Urethane	
8	Piston seal	NBR	

No.	Description	Material	Note
9	Tube gasket	NBR	
10	Return spring	Resin	
11	Wear ring	Piano wire	Zinc chromated
12	Spring seat	Aluminum alloy	
13	Rod end nut	Rolled steel	Zinc chromated
14	Magnet	—	
15	Rod seal	NBR	

Air Cylinder: Direct Mount, Non-rotating Rod Type Single Acting, Spring Return/Extend *Series CJ2RK*

Single Acting: Bottom Mounting Style

Spring return: CJ2RK Bore size – Stroke S Head cover port location Z

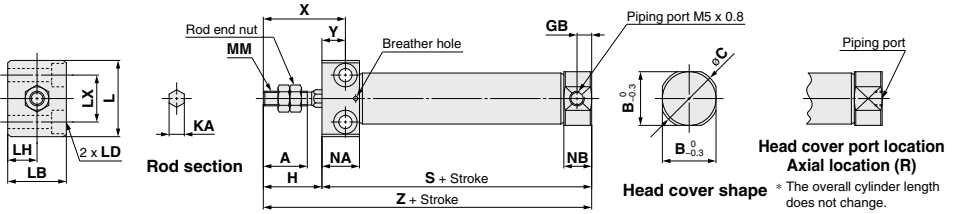

Bore size	A	B	C	GB	H	KA	L	LB	LD	LH	LX	MM	NA	NB	X	Y
10	15	12	14	5	20	4.2	23	16	ø3.5 through, ø6.5 counterbore depth 4	8	12	M4 x 0.7	12.8	9.5	28	8
16	15	18.3	20	5	20	5.2	26	20	ø4.5 through, ø8 counterbore depth 5	10	16	M5 x 0.8	12.8	9.5	28	8

(mm)

Dimensions by Stroke: Spring Return

Bore size	S								Z							
	5 to 15	16 to 30	31 to 45	46 to 60	61 to 75	76 to 100	101 to 125	126 to 150	5 to 15	16 to 30	31 to 45	46 to 60	61 to 75	76 to 100	101 to 125	126 to 150
10	53.5	61	73	85	—	—	—	—	73.5	81	93	105	—	—	—	—
16	53.5	62	74	86	92	116	134	146	73.5	82	94	106	112	136	154	166

(mm)

Spring extend: CJ2RK Bore size – Stroke TZ

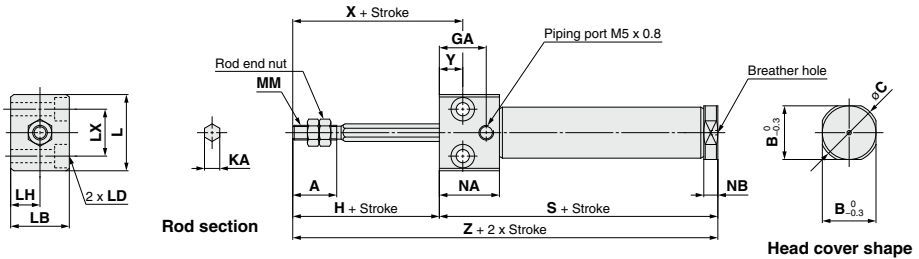

Bore size	A	B	C	GA	H	KA	L	LB	LD	LH	LX	MM	NA	NB	X	Y
10	15	12	14	16	20	4.2	23	16	ø3.5 through, ø6.5 counterbore depth 4	8	12	M4 x 0.7	20.5	4.8	28	8
16	15	18.3	20	16	20	5.2	26	20	ø4.5 through, ø8 counterbore depth 5	10	16	M5 x 0.8	20.5	4.8	28	8

(mm)

Dimensions by Stroke: Spring Extend (Dimensions not mentioned in the below table are the same as the above table.) (mm)

Bore size	S								Z							
	5 to 15	16 to 30	31 to 45	46 to 60	61 to 75	76 to 100	101 to 125	126 to 150	5 to 15	16 to 30	31 to 45	46 to 60	61 to 75	76 to 100	101 to 125	126 to 150
10	56.5	64	76	88	—	—	—	—	76.5	84	96	108	—	—	—	—
16	56.5	65	77	89	95	119	137	149	76.5	85	97	109	115	139	157	169

- Air Cylinders
- CJ2**
- CM2**
- CG1**
- MB**
- CA2**
- CQ2**
- CQS**
- Lube-retainer
- JA**
- MXH**
- MXQ**
- MGP**
- Y
- X
- CK□1**
- CL□**
- CL□U**
- CKQ**
- CKZZN**
- WRF**

Air Cylinder: With End Lock

Series **CBJ2**

ø16

How to Order

Built-in Magnet Cylinder Model

Suffix the symbol "A" (Rail mounting style) or "B" (Band mounting style) to the end of part number for cylinder with auto switch.

Example	Rail mounting style	CDBJ2B16-45-HN-A
	Band mounting style	CDBJ2B16-60-HN-B

- * For rail mounting, screws and nuts for 2 auto switches come with the rail.
- * Refer to page 459 for auto switch mounting brackets.

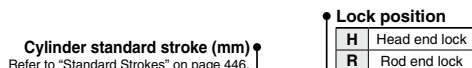

CBJ2 L 16-60-H N

With auto switch

CDBJ2 L 16-60-H N - M9BW - C

With auto switch
(Built-in magnet)

Manual release
N Non-locking type

Mounting

B	Basic
L	Axial foot
F	Rod flange
D	Double clevis <small>Note</small>

Note) Rod end lock only.

Auto switch

* For applicable auto switches, refer to the table below.

★ If a built-in magnet cylinder without an auto switch is required, refer to the model of built-in magnet cylinder.

Auto switch mounting bracket Note
Note) This symbol is indicated when the D-A9□□ or M9□□ type auto switch is specified. This mounting bracket does not apply to other auto switches (D-C7□□ and H7□□, etc.) (Nil)

Number of auto switches

Nil	2 pcs.
S	1 pc.
n	"n" pcs.

Applicable Auto Switches

Refer to the **WEB catalog** or the Best Pneumatics No. 2 for further information on auto switches.

Type	Special function	Electrical entry	Indicate light	Wiring (Output)	Load voltage		Auto switch model				Lead wire length (m)				Pre-wired connector	Applicable load	
					DC	AC	Band mounting		Rail mounting		0.5 (Nil)	1 (M)	3 (L)	5 (Z)			None (N)
							Perpendicular	In-line	Perpendicular	In-line							
Solid state auto switch	—	Grommet	No	3-wire (NPN)	5 V, 12 V	—	M9NV	M9N	M9NV	M9N	●	●	●	○	○	IC circuit	
				3-wire (PNP)			M9PV	M9P	M9PV	M9P	●	●	●	○	○		
		Connector	2-wire	—			H7C	J79C	—	●	—	●	●	—	—		—
			3-wire (NPN)	24 V			M9NVV	M9NV	M9NVV	M9NV	●	●	●	○	○		IC circuit
	3-wire (PNP)	M9PWW	M9PW		M9PWW	M9PW	●	●	●	○	○						
	Diagnostic indication (2-color indication)	Grommet	Yes	2-wire	5 V, 12 V	—	M9BWW	M9BW	M9BWW	M9BW	●	●	●	○	○	—	
				3-wire (NPN)	5 V, 12 V	M9NAV**	M9NA**	M9NAV**	M9NA**	○	○	○	○	○	IC circuit		
	Water resistant (2-color indication)	Grommet	No	3-wire (PNP)	5 V, 12 V	—	M9PAV**	M9PA**	M9PAV**	M9PA**	○	○	○	○		○	IC circuit
				2-wire	12 V	M9BAV**	M9BA**	M9BAV**	M9BA**	○	○	○	○	○			
	With diagnostic output (2-color indication)	Grommet	Yes	4-wire (NPN)	5 V, 12 V	—	—	H7NF	—	F79F	●	—	●	○	○	IC circuit	
3-wire (NPN equivalent)				5 V	—	A96V	A96	A96V	A96	●	—	●	—	—	IC circuit		
Reed auto switch	—	Grommet	Yes	2-wire	24 V	200 V	—	—	A72	A72H	●	—	●	—		—	—
						100 V	A93V	A93	A93V	A93	●	—	●	—	—		
						100 V or less	A90V	A90	A90V	A90	●	—	●	—	—		
		Connector	No			24 V or less	—	C73C	A73C	—	●	—	●	—	—	IC circuit	
						—	—	C80C	A80C	—	●	—	●	—	IC circuit		
						—	—	—	A79W	—	●	—	●	—			—
Diagnostic indication (2-color indication)	Grommet	Yes	—	—	—	—	—	—	—	—	—	—	—	—			

** Water resistant type auto switches can be mounted on the above models, but in such case SMC cannot guarantee water resistance.

Please contact SMC regarding water resistant types with the above model numbers.

* Lead wire length symbols: 0.5 m..... Nil (Example) M9NW
1 m..... M (Example) M9NWM
3 m..... L (Example) M9NWL
5 m..... Z (Example) M9NWZ
None..... N (Example) H7CN

* Since there are other applicable auto switches than listed, refer to page 460 for details.

* For details about auto switches with pre-wired connector, refer to the **WEB catalog** or the Best Pneumatics No. 2.

* Solid state auto switches marked with "○" are produced upon receipt of order.

* The D-A9□□/M9□□/A7□□/A8□□/F7□□/J7□□ auto switches are shipped together, (but not assembled). (However, when the D-A9□□/M9□□ types are selected, only auto switch mounting brackets are assembled before being shipped.)

* When the D-A9□□/M9□□ types are mounted on a rail, order auto switch mounting brackets separately. Refer to page 459 for details.

Series CJ2 air cylinder is equipped with end lock function.



Symbol

Rubber bumper

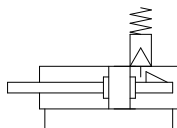

Specifications

Bore size (mm)	16
Action	Double acting, Single rod
Fluid	Air
Proof pressure	1 MPa
Maximum operating pressure	0.7 MPa
Minimum operating pressure	0.15 MPa*
Ambient and fluid temperature	Without auto switch: -10°C to 70°C With auto switch : -10°C to 60°C (No freezing)
Cushion	Rubber bumper
Lubrication	Not required (Non-lube)
Stroke length tolerance	+1.0 0
Piston speed	50 to 750 mm/s
Allowable kinetic energy	0.090 J

* 0.06 MPa for parts other than the lock unit.

Lock Specifications

Lock position	Head end, Rod end
Holding force (Max.)	98 N
Lock release pressure	0.15 MPa or less
Backlash	1 mm or less
Manual release	Non-locking type

Standard Strokes

Bore size	Standard stroke (mm)
16	15, 30, 45, 60, 75, 100, 125, 150, 175, 200

* Manufacture of intermediate strokes at 1 mm intervals is possible. (Spacers are not used.)

Mounting Brackets/Part No.

Mounting bracket	Bore size (mm)
	16
Foot	CJ-L016B
Flange	CJ-F016B
T-bracket*	CJ-T016B

* T-bracket is used with double clevis (D).

Refer to pages 453 to 460 for cylinders with auto switches.

- Auto switch proper mounting position (detection at stroke end) and its mounting height
- Minimum stroke for auto switch mounting
- Operating range
- Auto switch mounting brackets/Part no.

Moisture Control Tube Series IDK



When operating an actuator with a small diameter and a short stroke at a high frequency, the dew condensation (water droplet) may occur inside the piping depending on the conditions.

Simply connecting the moisture control tube to the actuator will prevent dew condensation from occurring. For details, refer to **Series IDK in the WEB catalog.**



Series CBJ2

Specific Product Precautions

Be sure to read this before handling. Please consult with SMC for products outside these specifications.

Use Recommended Air Pressure Circuit.

⚠ Caution

- It is necessary for proper locking and unlocking.

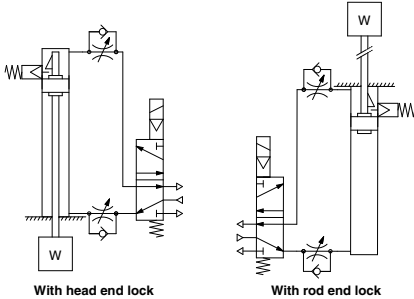

With head end lock

With rod end lock

Selection

⚠ Caution

- Do not use a 3 position solenoid valve.**
Avoid using this cylinder in combination with a 3 position solenoid valve (particularly the closed center metal seal type). If air pressure becomes sealed inside the port on the side that contains the lock mechanism, the lock will not engage. Even if the lock is engaged at first, the air that leaks from the solenoid valve could enter the cylinder and cause the lock to disengage as time elapses.
- Back pressure is necessary for unlocking.**
Before starting, make sure that air is supplied to the side that is not equipped with a lock mechanism as shown in the diagram above. Otherwise, the lock may not disengage. (Refer to "Rock Disengagement".)
- Disengage the lock before installing or adjusting the cylinder.**
The lock could become damaged if the cylinder is installed with its lock engaged.
- Operate the cylinder at a load ratio of 50% or less.**
The lock might not disengage or might become damaged if a load ratio of 50% is exceeded.
- Do not synchronize multiple cylinders.**
Do not operate two or more end lock cylinders synchronized to move a single workpiece because one of the cylinder locks may not be able to disengage when required.
- Operate the speed controller under meter-out control.**
If operated under meter-in control, the lock might not disengage.
- On the side that has a lock, make sure to operate at the stroke end of the cylinder.**
The lock might not engage or disengage if the piston of the cylinder has not reached the stroke end.
- The position adjustment of the auto switch should be performed at two positions; a position determined by the stroke and a position after the backlash movement (by 1 mm).**
When a 2-color indication switch is adjusted to show green at the stroke end, the indication may turn red when the cylinder returns by the backlash. This, however, is not an error.

Operating Pressure

⚠ Caution

Supply air pressure of 0.15 MPa or higher to the port on the side that has the lock mechanism, as it is necessary for disengaging the lock.

Exhaust Air Speed

⚠ Caution

The lock will engage automatically if the air pressure at the port on the side that has the lock mechanism becomes 0.05 MPa or less. Be aware that if the piping on the side that has the lock mechanism is narrow and long, or if the speed controller is located far from the cylinder port, the exhaust air speed could become slower, involving a longer time for the lock to engage. A similar result will ensure if the silencer that is installed on the exhaust port of the solenoid valve becomes clogged.

Lock Disengagement

⚠ Warning

To disengage the lock, make sure to supply air pressure to the port on the side without a lock mechanism, thus preventing the load from being applied to the lock mechanism. (Refer to the recommended air pressure circuit.) If the lock is disengaged when the port on the side that does not contain a lock mechanism is in the exhausted state and the load is being applied to the lock mechanism, undue force will be applied to the lock mechanism, and it may damage the lock mechanism. Also, it could be extremely dangerous, because the piston rod could move suddenly.

Manual Disengagement

⚠ Caution

Non-locking style manual release

Insert the bolt, which is provided as an accessory part, through the rubber cap (it is not necessary to remove the rubber cap). Screw the bolt into the lock piston and pull the bolt to disengage the lock. Releasing the bolt will re-engage the lock. The bolt size, pulling force, and the stroke are listed below.

Bore size (mm)	Thread size	Pulling force N	Stroke (mm)
16	M2.5 x 0.45 x 25L or more	4.9	2

Bolt should be detached under normal operation, otherwise it may cause malfunction of the locking feature.

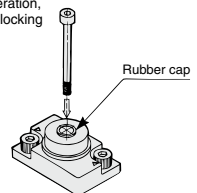

Construction (Not able to disassemble)

Head end lock

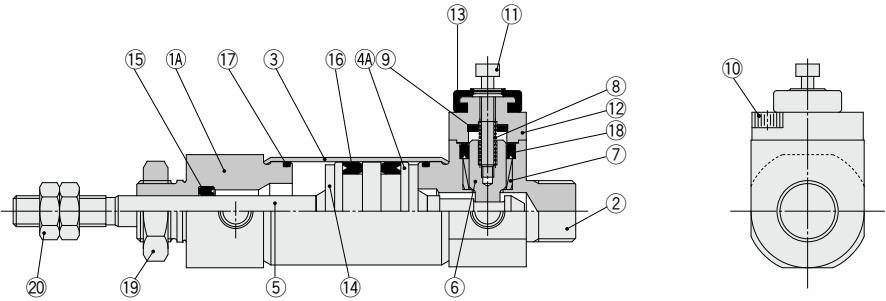

Rod end lock

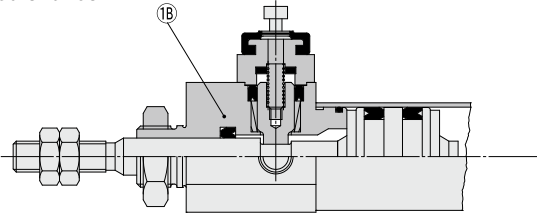

Built-in magnet

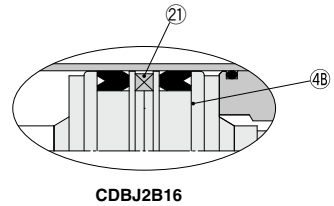

CDBJ2B16

Component Parts

No.	Description	Material	Note
1A	Rod cover	Aluminum alloy	Anodized
1B	Rod cover	Stainless steel	
2	Head cover	Aluminum alloy	Anodized
3	Cylinder tube	Stainless steel	
4A	Piston	Aluminum alloy	Trivalent chromated
4B	Piston B	Aluminum alloy	Trivalent chromated
5	Piston rod	Carbon steel	Heat treatment, Hard chrome plating
6	Locking piston	Carbon steel	Heat treatment, Hard chrome plating
7	Locking bushing	Copper alloy	
8	Lock spring	Spring steel	Trivalent zinc chromated
9	Bumper	Urethane	
10	Hexagon socket head cap screw	Alloy steel	Trivalent zinc chromated

No.	Description	Material	Note
11	Hexagon socket head cap screw	Alloy steel	Trivalent zinc chromated
12	Cap	Aluminum alloy	Black painting
13	Rubber cap	Synthetic rubber	
14	Bumper	Urethane	
15	Rod seal	NBR	
16	Piston seal	NBR	
17	Tube gasket	NBR	
18	Locking piston seal	NBR	
19	Mounting nut	Brass	Nickel plating
20	Rod end nut	Rolled steel	Trivalent zinc chromated
21	Magnet	—	CDBJ2

Air Cylinders

CJ2

CM2

CG1

MB

CA2

CQ2

CQS

Lube-retainer

JA

MXH

MXQ

MGP

C□Y

C□X

CK□1

C(L)□

C(L)KU

CKQ

CKZ2N

WRF

INDEX

Dimensions

Flange

With rod end lock: **C□BJ2F16-□□-RN**

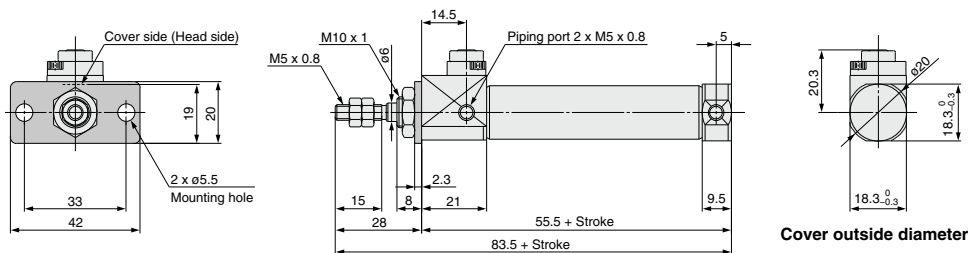

With head end lock: **C□BJ2F16-□□-HN**

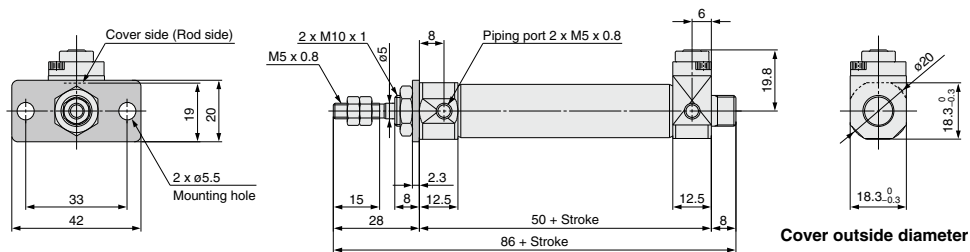

Air Cylinders

CJ2

CM2

CG1

MB

CA2

CQ2

CQS

Lube-retainer

JA

MXH

MXQ

MGP

C□Y

C□X

CK□1

C(L)□

C(L)XU

CKQ

CKZ2N

WRF

INDEX

Dimensions

Double clevis

With rod end lock: C□BJ2D16-□□-RN

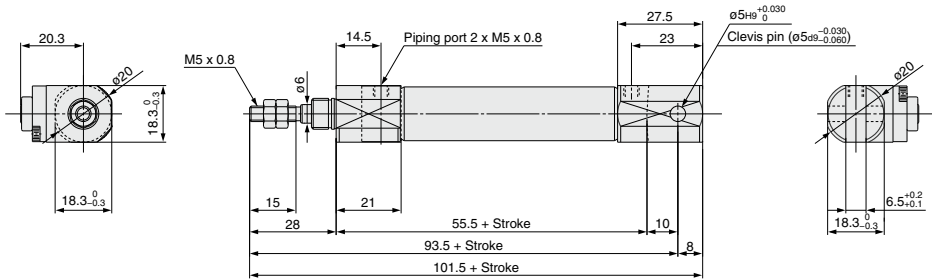

Air Cylinders

CJ2

CM2

CG1

MB

CA2

CQ2

CQS

Lube-

retainer

JA

MXH

MXQ

MGP

C□Y

C□X

CK□1

C(L)□

C(L)□U

CKQ

CKZ2N

WRF

INDEX

Auto Switch Mounting

Auto Switch Proper Mounting Position (Detection at stroke end) and Its Mounting Height

Solid state auto switch

<Band mounting>

D-M9□

D-M9□W

D-M9□A

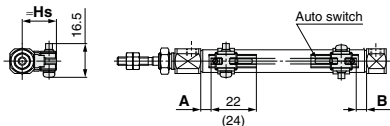

() : Dimension of the D-M9□A.

A and B are the dimensions from the end of the head cover/rod cover to the end of the auto switch.

D-M9□V

D-M9□MV

D-M9□AV

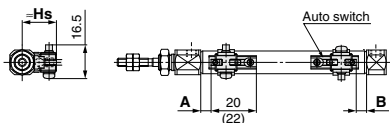

() : Dimension of the D-M9□AV.

A and B are the dimensions from the end of the head cover/rod cover to the end of the auto switch.

D-H7□

D-H7□W

D-H7BA

D-H7NF

D-H7C

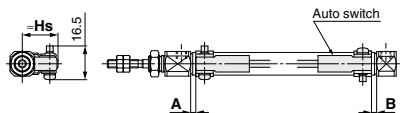

Reed auto switch

<Band mounting>

D-A9□

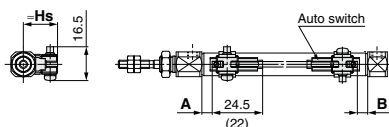

() : Dimension of the D-A96.

A and B are the dimensions from the end of the head cover/rod cover to the end of the auto switch.

D-A9□V

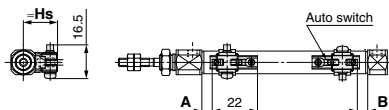

A and B are the dimensions from the end of the head cover/rod cover to the end of the auto switch.

D-C7□/C80

D-C73C□/C80C

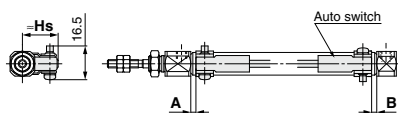

Auto Switch Proper Mounting Position (Detection at stroke end) and Its Mounting Height

<Rail mounting>

- D-M9□
- D-M9□W
- D-M9□A

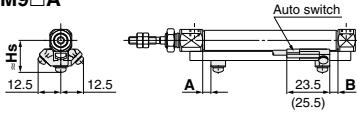

() : Dimension of the D-M9□A.

- D-M9□V
- D-M9□WV
- D-M9□AV

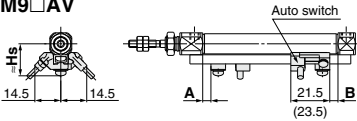

() : Dimension of the D-M9□AV.

- D-F7□/J79
- D-F7□W/J79W
- D-F79F/F7BA

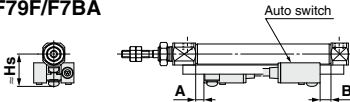

- D-F7□V/F7□WV
- D-F7BAV
- D-J79C

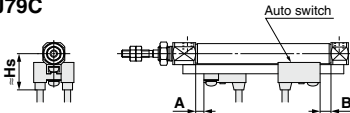

<Rail mounting>

- D-A9□

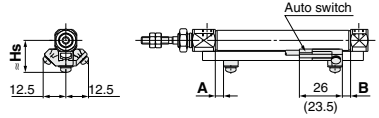

() : Dimension of the D-A96.

- D-A9□V

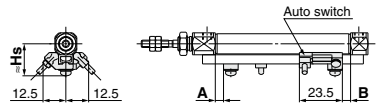

- D-A7□/A80
- D-A73C/A80C
- D-A79W

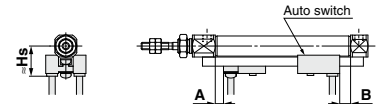

- D-A7□H/A80H

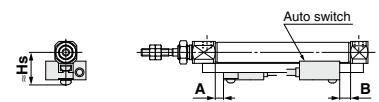

Air Cylinders

CJ2

CM2

CG1

MB

CA2

CQ2

CQS

Lube-retainer

JA

MXH

MXQ

MGP

C□Y

C□X

CK□1

C(L)□

C(L)KU

CKQ

CKZ2N

WRF

INDEX

Auto Switch Proper Mounting Position (Detection at stroke end) and Its Mounting Height

Auto Switch Proper Mounting Position (Single acting type excluded) (mm)

Auto switch model	Band mounting							
	D-M9□ D-M9□V D-M9□W D-M9□WV D-M9□A D-M9□AV		D-A9□ D-A9□V		D-H7□ D-H7C D-H7NF D-H7□W D-H7BA		D-C7□ D-C80 D-C73C D-C80C	
Bore size	A	B	A	B	A	B	A	B
6	5.5 (4.5) [12]	5.5 (4.5) [4]	1.5 (0.5) [8]	1.5 (0.5) [0]	1 (7.5)	1 (0)	2 (8.5)	2 (0.5)
10	(5) 6	(5) 6	(1) 2	(1) 2	1.5	1.5	2.5	2.5
16	(5.5) 6.5	(5.5) 6.5	(1.5) 2.5	(1.5) 2.5	2	2	3	3

* The values in () are measured from the end of the auto switch mounting bracket.

* The values in [] for bore size ø6 are for the double rod type (Series CJ2W).

(mm)

Auto switch model	Rail mounting											
	D-M9□ D-M9□V D-M9□W D-M9□WV D-M9□A D-M9□AV		D-A9□ D-A9□V		D-F7□/J79 D-F7□W/J79W D-F7□V/F7□WV D-F79F D-J79C D-F7BA D-F7BAV D-A7□H/A80H D-A73C/A80C		D-F7NT		D-A7□ D-A80		D-A79W	
Bore size	A	B	A	B	A	B	A	B	A	B	A	B
6	—	—	—	—	—	—	—	—	—	—	—	—
10	4.5	4.5	0.5	0.5	3.5	3.5	8.5	8.5	3	3	0.5	0.5
16	5	5	1	1	4	4	9	9	3.5	3.5	1	1

* Adjust the auto switch after confirming the operating condition in the actual setting.

Auto Switch Mounting Height

(mm)

Auto switch model	Band mounting				
	D-M9□ D-M9□W D-M9□A D-A9□	D-M9□V D-M9□WV D-M9□AV D-A9□V	D-H7□/H7□W D-H7NF D-H7BA D-C7□/C80	D-H7C	D-C73C D-C80C
Bore size	Hs	Hs	Hs	Hs	Hs
6	15	16	15	18	17.5
10	17	18	17	20	19.5
16	20.5	21	20.5	23.5	23

(mm)

Auto switch model	Rail mounting						
	D-M9□ D-M9□V D-M9□W D-M9□WV D-M9□A D-M9□AV D-A9□ D-A9□V	D-F7□/J79 D-F7□W/J79W D-F7BA/F79F D-F7NT D-A7□H/A80H	D-F7□V D-F7□WV D-F7BAV	D-J79C	D-A7□ D-A80	D-A73C D-A80C	D-A79W
Bore size	Hs	Hs	Hs	Hs	Hs	Hs	
6	—	—	—	—	—	—	
10	17.5	17.5	20	23	16.5	19	
16	21	20.5	23	26	19.5	22	

Auto Switch Proper Mounting Position (Detection at stroke end) and Its Mounting Height/Single Acting, Spring Return Type (S)

Auto Switch Proper Mounting Position: Spring Return Type (S)

- Standard Type (CDJ2□□□-□SZ)
- Non-rotating Rod Type (CDJ2K□□□-□SZ)
- Direct Mount Type (CDJ2R□□□-□SZ)
- Direct Mount, Non-Rotating Rod Type (CDJ2RK□□□-□SZ)

Auto switch model	Bore size	A dimensions									B	
		5 to 9 st	10 to 15 st	16 to 30 st	31 to 45 st	46 to 60 st	61 to 75 st	76 to 100 st	101 to 125 st	126 to 150 st		
Band mounting	D-M9□	6	—	12	21	25	39	—	—	—	—	5.5
	D-M9□W/M9□WV D-M9□A/M9□AV	10	—	13	20.5	32.5	44.5	—	—	—	—	6
	D-M9□V	16	—	12.5	21	33	45	51	75	93	105	6.5
		6	12	12	21	25	39	—	—	—	—	5.5
	D-A9□	10	13	13	20.5	32.5	44.5	—	—	—	—	6
		16	12.5	12.5	21	33	45	51	75	93	105	6.5
	D-A9□V	6	—	8	17	21	35	—	—	—	—	1.5
		10	—	9	16.5	28.5	40.5	—	—	—	—	2
	D-A9□V	16	—	8.5	17	29	41	47	71	89	101	2.5
		6	8	8	17	21	35	—	—	—	—	1.5
		10	9	9	16.5	28.5	40.5	—	—	—	—	2
	D-H7□/H7C D-H7□W/H7BA D-H7NF	16	8.5	8.5	17	29	41	47	71	89	101	2.5
		6	—	7.5	16.5	20.5	34.5	—	—	—	—	1
		10	—	8.5	16	28	40	—	—	—	—	1.5
	D-C7□/C80 D-C73C D-C80C	16	—	8	16.5	28.5	40.5	46.5	70.5	88.5	100.5	2
		6	—	8.5	17.5	21.5	35.5	—	—	—	—	2
		10	—	9.5	17	29	41	—	—	—	—	2.5
	D-M9□ D-M9□W/M9□WV D-M9□A/M9□AV	16	—	9	17.5	29.5	41.5	47.5	71.5	89.5	101.5	3
		10	—	11.5	19	31	43	—	—	—	—	4.5
		16	—	11	19.5	31.5	43.5	49.5	73.5	91.5	103.5	5
	D-M9□V	10	11.5	11.5	19	31	43	—	—	—	—	4.5
		16	11	11	19.5	31.5	43.5	49.5	73.5	91.5	103.5	5
	D-A9□	10	—	7.5	15	27	39	—	—	—	—	0.5
		16	—	7	15.5	27.5	39.5	45.5	69.5	87.5	99.5	1
D-A9□V	10	7.5	7.5	15	27	39	—	—	—	—	0.5	
	16	7	7	15.5	27.5	39.5	45.5	69.5	87.5	99.5	1	
D-F7□/F7□V D-J79/J79C D-A7□H/A80H D-A73C/A80C	10	10.5	10.5	18	30	42	—	—	—	—	3.5	
	16	10	10	18.5	30.5	42.5	48.5	72.5	90.5	102.5	4	
D-F7□W/J79W D-F7□WV/F79F D-F7BA/F7BAV	10	—	10.5	18	30	42	—	—	—	—	3.5	
	16	—	10	18.5	30.5	42.5	48.5	72.5	90.5	102.5	4	
D-F7NT	10	—	15.5	23	35	47	—	—	—	—	8.5	
	16	—	15	23.5	35.5	47.5	53.5	77.5	95.5	107.5	9	
D-A7□/A80	10	10	10	17.5	29.5	41.5	—	—	—	—	3	
	16	9.5	9.5	18	30	42	48	72	90	102	3.5	
D-A79W	10	—	7.5	15	27	39	—	—	—	—	0.5	
	16	—	7	15.5	27.5	39.5	45.5	69.5	87.5	99.5	1	

* In the actual setting, adjust them after confirming the auto switch performance.

Air Cylinders

CJ2

CM2

CG1

MB

CA2

CQ2
CQS

Lube-retainer

JA

MXH

MXQ

MGP

C□Y
C□X

CK□1

C(L)□

C(L)KU

CKQ

CKZ2N

WRF

Auto Switch Proper Mounting Position (Detection at stroke end) and Its Mounting Height/Single Acting, Spring Extend Type (T)

Auto Switch Proper Mounting Position: Spring Extend Type (T)

- Standard Type (CDJ2□□□-□TZ)
- Non-rotating Rod Type (CDJ2K□□□-□TZ)
- Direct Mount Type (CDJ2R□□□-□TZ)
- Direct Mount, Non-rotating Rod Type (CDJ2RK□□□-□TZ)

(mm)

Auto switch model	Bore size	A	B dimensions									
			5 to 9 st	10 to 15 st	16 to 30 st	31 to 45 st	46 to 60 st	61 to 75 st	76 to 100 st	101 to 125 st	126 to 150 st	
Band mounting	D-M9□	6	5.5	—	12	21	25	39	—	—	—	—
	D-M9□W/M9□WV D-M9□A/M9□AV	10	6	—	13	20.5	32.5	44.5	—	—	—	—
	D-M9□V	16	6.5	—	12.5	21	33	45	51	75	93	105
		6	5.5	12	12	21	25	39	—	—	—	—
	D-A9□	10	6	13	13	20.5	32.5	44.5	—	—	—	—
		16	6.5	12.5	12.5	21	33	45	51	75	93	105
	D-A9□V	6	1.5	—	8	17	21	35	—	—	—	—
		10	2	—	9	16.5	28.5	40.5	—	—	—	—
	D-A9□V	16	2.5	—	8.5	17	29	41	47	71	89	101
		6	1.5	8	8	17	21	35	—	—	—	—
	D-H7□/H7C D-H7□W/H7BA D-H7NF	10	2	—	9	16.5	28.5	40.5	—	—	—	—
		16	2.5	8.5	8.5	17	29	41	47	71	89	101
	D-C7□/C80 D-C73C D-C80C	6	1	—	7.5	16.5	20.5	34.5	—	—	—	—
		10	1.5	—	8.5	16	28	40	—	—	—	—
	D-M9□ D-M9□W/M9□WV D-M9□A/M9□AV	16	2	—	8	16.5	28.5	40.5	46.5	70.5	88.5	100.5
		6	2	—	8.5	17.5	21.5	35.5	—	—	—	—
	D-M9□ D-M9□W/M9□WV D-M9□A/M9□AV	10	2.5	—	9.5	17	29	41	—	—	—	—
		16	3	—	9	17.5	29.5	41.5	47.5	71.5	89.5	101.5
	D-M9□ D-M9□W/M9□WV D-M9□A/M9□AV	10	4.5	—	11.5	19	31	43	—	—	—	—
		16	5	—	11	19.5	31.5	43.5	49.5	73.5	91.5	103.5
	D-M9□V	10	4.5	11.5	11.5	19	31	43	—	—	—	—
		16	5	11	11	19.5	31.5	43.5	49.5	73.5	91.5	103.5
	D-A9□	10	0.5	—	7.5	15	27	39	—	—	—	—
		16	1	—	7	15.5	27.5	39.5	45.5	69.5	87.5	99.5
D-A9□V	10	0.5	7.5	7.5	15	27	39	—	—	—	—	
	16	1	7	7	15.5	27.5	39.5	45.5	69.5	87.5	99.5	
D-F7□/F7□V D-J79/J79C D-A7□H/A80H D-A73C/A80C	10	3.5	10.5	10.5	18	30	42	—	—	—	—	
	16	4	10	10	18.5	30.5	42.5	48.5	72.5	90.5	102.5	
D-F7□W/J79W D-F7□WV/F79F D-F7BA/F7BAV	10	3.5	—	10.5	18	30	42	—	—	—	—	
	16	4	—	10	18.5	30.5	42.5	48.5	72.5	90.5	102.5	
D-F7NT	10	8.5	—	15.5	23	35	47	—	—	—	—	
	16	9	—	15	23.5	35.5	47.5	53.5	77.5	95.5	107.5	
D-A7□/A80	10	3	10	10	17.5	29.5	41.5	—	—	—	—	
	16	3.5	9.5	9.5	18	30	42	48	72	90	102	
D-A79W	10	0.5	—	7.5	15	27	39	—	—	—	—	
	16	1	—	7	15.5	27.5	39.5	45.5	69.5	87.5	99.5	

* In the actual setting, adjust them after confirming the auto switch performance.

Minimum Stroke for Auto Switch Mounting

Auto switch mounting	Auto switch model	Number of auto switches (mm)				
		With 1 pc.	With 2 pcs.		With n pcs. (n: Number of auto switches)	
			Different surfaces	Same surface	Different surfaces	Same surface
Band mounting	D-M9□ D-M9□W D-M9□A D-A9□	10	15 Note 1)	45 Note 1)	$15 + 35 \frac{(n-2)}{2}$ (n = 2, 4, 6...) ^{Note 3)}	45 + 15 (n - 2) (n = 2, 3, 4, 5...)
	D-M9□V	5	15 Note 1)	35	$15 + 35 \frac{(n-2)}{2}$ (n = 2, 4, 6...) ^{Note 3)}	35 + 25 (n - 2) (n = 2, 3, 4, 5...)
	D-M9□WV D-M9□AV	10	15 Note 1)	35	$15 + 35 \frac{(n-2)}{2}$ (n = 2, 4, 6...) ^{Note 3)}	35 + 25 (n - 2) (n = 2, 3, 4, 5...)
	D-A9□V	5	10	35	$10 + 35 \frac{(n-2)}{2}$ (n = 2, 4, 6...) ^{Note 3)}	35 + 25 (n - 2) (n = 2, 3, 4, 5...)
	D-H7□/H7□W D-H7BA D-H7NF	10	15	60	$15 + 45 \frac{(n-2)}{2}$ (n = 2, 4, 6...) ^{Note 3)}	60 + 22.5 (n - 2) (n = 2, 3, 4, 5...)
	D-C7□ D-C80	10	15	50	$15 + 40 \frac{(n-2)}{2}$ (n = 2, 4, 6...) ^{Note 3)}	50 + 20 (n - 2) (n = 2, 3, 4, 5...)
	D-H7C D-C73C D-C80C	10	15	65	$15 + 50 \frac{(n-2)}{2}$ (n = 2, 4, 6...) ^{Note 3)}	50 + 27.5 (n - 2) (n = 2, 3, 4, 5...)
Rail mounting	D-M9□V	5	—	5	—	10 + 10 (n - 2) (n = 4, 6...) ^{Note 4)}
	D-A9□V	5	—	10	—	10 + 15 (n - 2) (n = 4, 6...) ^{Note 4)}
	D-M9□ D-A9□	10 (5) ^{Note 5)}	—	10	—	15 + 15 (n - 2) (n = 4, 6...) ^{Note 4)}
	D-M9□WV D-M9□AV	10	—	15	—	15 + 15 (n - 2) (n = 4, 6...) ^{Note 4)}
	D-M9□W	15 (10) ^{Note 5)}	—	15	—	20 + 15 (n - 2) (n = 4, 6...) ^{Note 4)}
	D-M9□A	15 (10) ^{Note 5)}	—	20 (15) ^{Note 5)}	—	20 + 15 (n - 2) (n = 4, 6...) ^{Note 4)}
	D-F7□ D-J79	5	—	5	—	15 + 15 (n - 2) (n = 4, 6...) ^{Note 4)}
	D-F7□V D-J79C	5	—	5	—	10 + 10 (n - 2) (n = 4, 6...) ^{Note 4)}
	D-F7□W/J79W D-F7BA/F79F/F7NT	10	—	15	—	15 + 20 (n - 2) (n = 4, 6...) ^{Note 4)}
	D-F7□WV D-F7BAV	10	—	15	—	10 + 15 (n - 2) (n = 4, 6...) ^{Note 4)}
	D-A7□/A80 D-A7□H/A80H D-A73C/A80C	5	—	10	—	15 + 10 (n - 2) (n = 4, 6...) ^{Note 4)}
	D-A7□H D-A80H	5	—	10	—	15 + 15 (n - 2) (n = 4, 6...) ^{Note 4)}
	D-A79W	10	—	15	—	10 + 15 (n - 2) (n = 4, 6...) ^{Note 4)}

Note 3) When "n" is an odd number, an even number that is one larger than this odd number is used for the calculation.
 Note 4) When "n" is an odd number, an even number that is one larger than this odd number is used for the calculation. However, the minimum even number is 4. So, 4 is used for the calculation when "n" is 1 to 3.
 Note 5) The dimension stated in () shows the minimum mountable stroke when the auto switch does not project from the end face of the cylinder body and the lead wire bending space is not hindered.

Note 1) Auto switch mounting

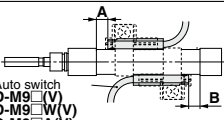
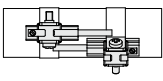
Auto switch model	With 2 auto switches	
	Different surfaces ^{Note 1)}	Same surface ^{Note 1)}
 <p>Auto switch D-M9□(V) D-M9□W(V) D-M9□A(V)</p> <p>The proper auto switch mounting position is 5.5 mm inward from the switch holder edge. The above A and B indicate values for band mounting in the table of page 455.</p>	 <p>The auto switch is mounted by slightly displacing it in a direction (cylinder tube circumferential exterior) so that the auto switch and lead wire do not interfere with each other.</p>	
D-M9□/M9□W/M9□A	Less than 20 stroke ^{Note 2)}	Less than 55 stroke ^{Note 2)}
D-A9□	—	Less than 50 stroke ^{Note 2)}

Note 2) Minimum stroke for auto switch mounting in styles other than those mentioned in Note 1.

Air Cylinders
CJ2
CM2
CG1
MB
CA2
CQ2
CQS
 Lube-retainer
JA
MXH
MXQ
MGP
CQY
CQX
CK1
CLK□
CLJKU
CKQ
CKZN
WRF

INDEX

Operating Range

Auto switch model		Bore size (mm)		
		6	10	16
Band mounting	D-M9□/M9□V D-M9□W/M9□WV D-M9□A/M9□AV	2	2.5	3
	D-A9□	4.5	6	7
	D-H7□/H7□W D-H7BA/H7NF	3	4	4
	D-H7C	5	8	9
	D-C7□/C80/C73C/C80C	6	7	7
Rail mounting	D-M9□/M9□V D-M9□W/M9□WV D-M9□A/M9□AV	—	3	3.5
	D-A9□/A9□V	—	6	6.5
	D-F7□/J79/F7□W/J79W D-F7□V/F7□WV/F79F D-J79C/F7BA/F7BAV D-F7NT	—	5	5
	D-A7□/A80/A7H/A80H D-A73C/A80C	—	8	9
	D-A79W	—	11	13

* Values which include hysteresis are for guideline purposes only, they are not a guarantee (assuming approximately ±30% dispersion) and may change substantially depending on the ambient environment.

Auto Switch Mounting Brackets/Part No.

Auto switch mounting	Auto switch model	Bore size (mm)		
		6	10	16
Band mounting	D-M9□ D-M9□V D-M9□W D-M9□WV D-A9□ D-A9□V	BJ6-006 (A set of a, b, d, f)	BJ6-010 (A set of a, b, c, d)	BJ6-016 (A set of a, b, c, d)
	D-M9□A ^{Note 2)} D-M9□AV ^{Note 2)}	BJ6-006S (A set of a, b, d, g)	BJ6-010S (A set of a, b, d, e)	BJ6-016S (A set of a, b, d, e)
Band mounting				
Band mounting	D-H7□/H7□W D-H7BA/H7NF D-C7□/C80 D-C73C/C80C	BJ2-006 (A set of band and screw)	BJ2-010 (A set of band and screw)	BJ2-016 (A set of band and screw)
Rail mounting	D-M9□ D-M9□V D-M9□W D-M9□WV D-M9□A ^{Note 4)} D-M9□AV ^{Note 4)} D-A9□ D-A9□V		BQ2-012 (S) (A set of a and b)	BQ2-012 (S) (A set of a and b)

Note 1) Since the switch bracket (made from nylon) are affected in an environment where alcohol, chloroform, methylamines, hydrochloric acid or sulfuric acid is splashed over, so it cannot be used. Please contact SMC regarding other chemicals.

Note 2) As the indicator LED is projected from the switch unit, indicator LED may be damaged if the switch bracket is fixed on the indicator LED.

Note 3) When the cylinder is shipped, the auto switch mounting bracket and the auto switch will be included.

Note 4) For D-M9□A(V), order the BQ2-012S, which uses stainless steel mounting screws.

Band Mounting Brackets Set Part No.

Set part no.	Contents
BJ2-□□□	• Auto switch mounting band (a) • Auto switch mounting screw (b)
BJ4-1	• Switch bracket (White/PBT) (e) • Switch holder (d)
BJ4-2	• Switch bracket (Black/PBT) (g) • Switch holder (d)
BJ5-1	• Switch bracket (Transparent/Nylon) (c) • Switch holder (d)
BJ5-2	• Switch bracket (Transparent blue/Nylon) (f) • Switch holder (d)

[Stainless Steel Mounting Screw]

The following stainless steel mounting screw kit is available. Use it in accordance with the operating environment. (Since the auto switch mounting bracket is not included, order it separately.)

BBA4: For D-C7/C8/H7 types

Note 5) Refer to the **WEB catalog** or the Best Pneumatics No. 2 for details on the BBA4.

When the D-H7BA type auto switch is shipped independently, the BBA4 is attached.

Other than the applicable auto switches listed in “How to Order”, the following auto switches are mountable.

Refer to the **WEB catalog** or the Best Pneumatics No.2 for the detailed specifications.

Type	Mounting	Model	Electrical entry	Features	Applicable bore size
Solid state	Band mounting	D-H7A1/H7A2/H7B	Grommet (In-line)	—	ø6 to ø16
		D-H7NW/H7PW/H7BW		Diagnostic indication (2-color indication)	
		D-F79/F7P/J79		—	
	Rail mounting	D-F79W/F7PW/J79W	Grommet (Perpendicular)	Diagnostic indication (2-color indication)	ø10, ø16
		D-F7NV/F7PV/F7BV		—	
		D-F7NWW/F7BWV		Diagnostic indication (2-color indication)	
Reed	Band mounting	D-C73/C76	Grommet (In-line)	—	ø6 to ø16
		D-C80		Without indicator light	
	Rail mounting	D-A73H/A76H	Grommet (Perpendicular)	—	ø10, ø16
		D-A80H		Without indicator light	
		D-A73		—	
		D-A80		Without indicator light	
		D-A80		Without indicator light	

* With pre-wired connector is also available for solid state auto switches. For details, refer to the **WEB catalog** or the Best Pneumatics No. 2.

* Normally closed (NC = b contact) solid state auto switches (D-F9G/F9H) are also available. For details, refer to the **WEB catalog** or the Best Pneumatics No. 2.

Air Cylinders

CJ2

CM2

CG1

MB

CA2

CQ2

CQS

Lube-retainer

JA

MXH

MXQ

MGP

C□Y

C□X

CK□1

C(L)□

C(L)□U

CKQ

CKZZN

WRF

INDEX

Prior to Use

Auto Switch Connection and Example

Sink Input Specifications

3-wire, NPN

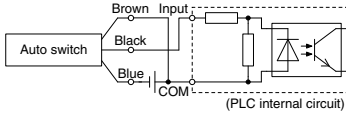

2-wire

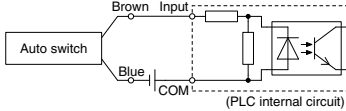

Source Input Specifications

3-wire, PNP

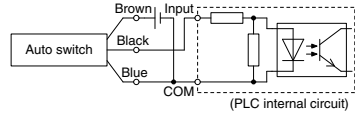

2-wire

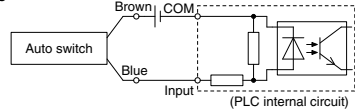

Connect according to the applicable PLC input specifications, as the connection method will vary depending on the PLC input specifications.

Example of AND (Series) and OR (Parallel) Connection

* When using solid state auto switches, ensure the application is set up so the signals for the first 50 ms are invalid.

3-wire AND connection for NPN output (Using relays)

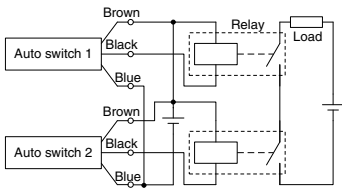

(Performed with auto switches only)

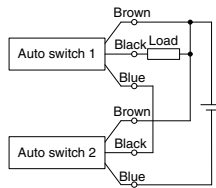

3-wire OR connection for NPN output

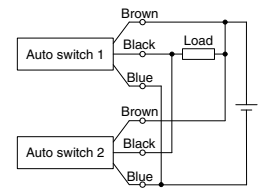

3-wire AND connection for PNP output (Using relays)

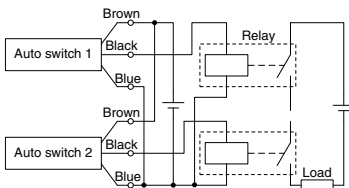

(Performed with auto switches only)

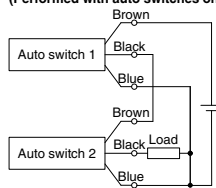

3-wire OR connection for PNP output

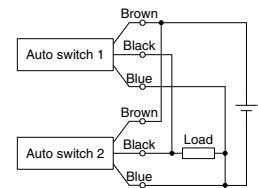

2-wire AND connection

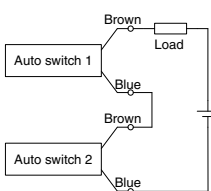

When two auto switches are connected in series, a load may malfunction because the load voltage will decline when in the ON state. The indicator lights will light up when both of the auto switches are in the ON state. Auto switches with load voltage less than 20 V cannot be used.

$$\begin{aligned} \text{Load voltage at ON} &= \text{Power supply voltage} - \\ &\quad \text{Residual voltage} \times 2 \text{ pcs.} \\ &= 24 \text{ V} - 4 \text{ V} \times 2 \text{ pcs.} \\ &= 16 \text{ V} \end{aligned}$$

Example: Power supply is 24 VDC
Internal voltage drop in auto switch is 4 V.

2-wire OR connection

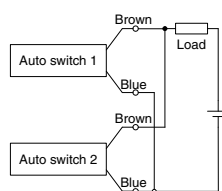

(Solid state)
When two auto switches are connected in parallel, malfunction may occur because the load voltage will increase when in the OFF state.

(Reed)
Because there is no current leakage, the load voltage will not increase when turned OFF. However, depending on the number of auto switches in the ON state, the indicator lights may sometimes grow dim or not light up, due to the dispersion and reduction of the current flowing to the auto switches.

$$\begin{aligned} \text{Load voltage at OFF} &= \text{Leakage current} \times 2 \text{ pcs.} \times \\ &\quad \text{Load impedance} \\ &= 1 \text{ mA} \times 2 \text{ pcs.} \times 3 \text{ k}\Omega \\ &= 6 \text{ V} \end{aligned}$$

Example: Load impedance is 3 k Ω .
Leakage current from auto switch is 1 mA.

Air Cylinders

CJ2

CM2

CG1

MB

CA2

CQ2

CQS

Lube-
retainer

JA

MXH

MXQ

MGP

C□Y

C□X

CK□1

C(L)K□

C(L)KU

CKQ

CKZ2N

WRF



Please contact SMC for detailed specifications, delivery and prices.

Simple Specials The following special specifications can be ordered as a simplified Made-to-Order. There is a specification sheet available on paper and CD-ROM. Please contact your SMC sales representatives if necessary.

Symbol	Specifications	CJ2 (Standard type)				CJ2K (Non-rotating rod type)		
		Double acting		Single acting		Double acting		Single acting
		Single rod	Double rod	Single rod (spring return)	Single rod (spring extend)	Single rod	Single rod (spring return)	Single rod (spring extend)
-XA0, 1, 10, 11	Change of rod end shape	●	●	●	●	●	●	●

Made to Order

Symbol	Specifications	CJ2 (Standard type)				CJ2K (Non-rotating rod type)		
		Double acting		Single acting		Double acting		Single acting
		Single rod	Double rod	Single rod (spring return)	Single rod (spring extend)	Single rod	Single rod (spring return)	Single rod (spring extend)
-XB6	Heat resistant cylinder (-10 to 150°C)	●	●					
-XB7	Cold resistant cylinder (-40 to 70°C)	●	●					
-XB9	Low speed cylinder (10 to 50 mm/s)	●						
-XB13	Low speed cylinder (5 to 50 mm/s) (ø6 only)	●						
-XC3	Special port position	●				●		
-XC8	Adjustable stroke cylinder/Adjustable extension type	●						
-XC9	Adjustable stroke cylinder/Adjustable retraction type	●						
-XC10	Dual stroke cylinder/Double rod type	●				●		
-XC11	Dual stroke cylinder/Single rod type	●						
-XC22	Fluororubber seal	●	●	●	●	●		
-XC51	With hose nipple	●	●	●	●	●	●	●
-XC85	Grease for food processing equipment	●	●	●	●	●	●	●
-X446	PTFE grease	●	●	●	●	●	●	●
-X773	Short pitch mounting (ø6 only)			●				

CJ2Z (Built-in speed controller type) Double acting		CJ2R (Direct mount type) Double acting Single acting			CJ2RK (Direct mount, Non-rotating rod type) Double acting Single acting			Symbol	Page
Single rod	Double rod	Single rod	Single rod (spring return)	Single rod (spring extend)	Single rod	Single rod (spring return)	Single rod (spring extend)		
●	●	●	●	●	●	●	●	-XA0, 1, 10, 11	Page 465

CJ2Z (Built-in speed controller type) Double acting		CJ2R (Direct mount type) Double acting Single acting			CJ2RK (Direct mount, Non-rotating rod type) Double acting Single acting			Symbol	Page
Single rod	Double rod	Single rod	Single rod (spring return)	Single rod (spring extend)	Single rod	Single rod (spring return)	Single rod (spring extend)		
			●			●		-XB6	Page 466
								-XB7	Page 466
								-XB9	Page 466
								-XB13	Page 467
								-XC3	Page 467
			●			●		-XC8	Page 467
								-XC9	Page 468
								-XC10	Page 468
								-XC11	Page 469
			●					-XC22	Page 470
●	●	●	●	●	●	●	●	-XC51	Page 470
●	●	●	●	●	●	●	●	-XC85	Page 471
●	●	●	●	●	●	●	●	-X446	Page 471
								-X773	Page 472

Air Cylinders

- CJ2**
- CM2**
- CG1**
- MB**
- CA2**
- CQ2**
- CQS**
- Lube-retainer
- JA**
- MXH**
- MXQ**
- MGP**
- C□Y**
- C□X**
- CK□1**
- C(L)□**
- C(L)□U**
- CKQ**
- CKZ2N**
- WRF**

INDEX

Series CJ2 Simple Specials

These changes are dealt with Simple Specials System.

For details, refer to the Simple Specials System in the WEB catalog.
<http://www.smcworld.com>

1 Change of Rod End Shape

Symbol

-XA0, 1, 10, 11

Applicable Series

Series		Action	Symbol for change of rod end shape	Note	
CJ2-Z	Standard type	CJ2	Double acting, Single rod	XA0, 1, 10, 11	*1
			Single acting (Spring return/extend)	XA0, 1, 10, 11	*1
		CJ2W	Double acting, Double rod	XA0, 1, 10, 11	
	Non-rotating rod type	CJ2K	Double acting, Single rod	XA0, 1, 10, 11	*1
			Single acting (Spring return/extend)	XA0, 1, 10, 11	*1
	Built-in speed controller type	CJ2Z	Double acting, Single rod	XA0, 1, 10, 11	*1
		CJ2ZW	Double acting, Double rod	XA0, 1, 10, 11	*1
	Direct mount type	CJ2RA	Double acting, Single rod	XA0, 1, 10, 11	*2
			Single acting (Spring return/extend)	XA0, 1, 10, 11	*2
	Direct mount, Non-rotating rod type	CJ2RK	Double acting, Single rod	XA0, 1, 10, 11	*2
Single acting (Spring return/extend)			XA0, 1, 10, 11	*2	

*1: Except rod end bracket and pivot bracket *2: Except rod end bracket

Precautions

- SMC will make appropriate arrangements if no dimension, tolerance, or finish instructions are given in the diagram.
- Standard dimensions marked with "*" will be as follows to the rod diameter (D). Enter any special dimension you desire.

- $D \leq 6 \rightarrow D - 1 \text{ mm}$, $6 < D \leq 25 \rightarrow D - 2 \text{ mm}$, $D > 25 \rightarrow D - 4 \text{ mm}$
- In the case of double rod type and single acting retraction type, enter the dimensions when the rod is retracted.

Symbol: A0	Symbol: A1	Symbol: A10	Symbol: A11

Series CJ2

Made to Order

Please contact SMC for detailed dimensions, specifications and lead times.



1 Heat Resistant Cylinder (-10 to 150°C)

Symbol

-XB6

Air cylinder which changed the seal material and grease, so that it could be used even at higher temperature up to 150 from -10°C.

Applicable Series

Description	Model	Action	Note
Standard type	CJ2	Double acting, Single rod	Except with air cushion and auto switch
	CJ2W	Double acting, Double rod	Except with air cushion and auto switch

- Note 1) Operate without lubrication from a pneumatic system lubricator.
 Note 2) Please contact SMC for details on the maintenance intervals for this cylinder, which differ from those of the standard cylinder.
 Note 3) In principle, it is impossible to make built-in magnet type and the one with auto switch. But, as for the one with auto switch, and the heat resistant cylinder with heat resistant auto switch, please contact SMC.
 Note 4) Piston speed is ranged from 50 to 500 mm/s.

How to Order

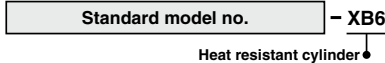

Specifications

Ambient temperature range	-10°C to 150°C
Seals material	Fluororubber
Grease	Heat resistant grease
Specifications other than above and external dimensions	Same as standard type

Warning Precautions

Be aware that smoking cigarettes etc. after your hands have come into contact with the grease used in this cylinder can create a gas that is hazardous to humans.

2 Cold Resistant Cylinder (-40 to 70°C)

Symbol

-XB7

Air cylinder which changed the seal material and grease, so that it could be used even at lower temperature down to -40°C.

Applicable Series

Description	Model	Action	Note
Standard type	CJ2	Double acting, Single rod	Except with air cushion and auto switch, rod end bracket, pivot bracket
	CJ2W	Double acting, Double rod	Except with air cushion and auto switch

- Note 1) Operate without lubrication from a pneumatic system lubricator.
 Note 2) Use dry air which is suitable for heatless air dryer, etc. not to cause the moisture to be frozen.
 Note 3) Please contact SMC for details on the maintenance intervals for this cylinder, which differ from those of the standard cylinder.
 Note 4) Mounting auto switch is impossible.
 Note 5) Piston speed is ranged from 50 to 500 mm/s.

How to Order

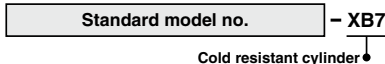

Specifications

Ambient temperature range	-40°C to 70°C
Seals material	Low nitrile rubber
Grease	Cold resistant grease
Auto switch	Not mountable
Dimensions	Same as standard type
Additional specifications	Same as standard type

Warning Precautions

Be aware that smoking cigarettes etc. after your hands have come into contact with the grease used in this cylinder can create a gas that is hazardous to humans.

3 Low Speed Cylinder (10 to 50 mm/s)

Symbol

-XB9

Even if driving at lower speeds 10 to 50 mm/s, there would be no stick-slip phenomenon and it can run smoothly.

Applicable Series

Description	Model	Action	Note
Standard type	CJ2	Double acting, Single rod	Except with air cushion

How to Order

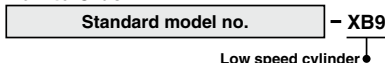

Specifications

Piston speed	10 to 50 mm/s
Dimensions	Same as standard type
Additional specifications	Same as standard type

Note) Operate without lubrication from a pneumatic system lubricator.

Warning Precautions

Be aware that smoking cigarettes etc. after your hands have come into contact with the grease used in this cylinder can create a gas that is hazardous to humans.

Air Cylinders

CJ2

CM2

CG1

MB

CA2

CQ2

CQS

Lube-retainer

JA

MXH

MXQ

MGP

Y

X

CK□1

(L)K

(L)KU

CKQ

CKZ2N

WRF

4 Low Speed Cylinder (5 to 50 mm/s)

Symbol
-XB13

Even if driving at lower speeds 5 to 50 mm/s, there would be no stick-slip phenomenon and it can run smoothly.

Applicable Series

Description	Model	Action	Note
Standard type	CJ2	Double acting, Single rod	ø6 only

Note 1) Operate without lubrication from a pneumatic system lubricator.
Note 2) For the speed adjustment, use speed controllers for controlling at lower speeds. (Series AS-FM/AS-M)

How to Order

Standard model no.	-XB13
--------------------	-------

Low speed cylinder

Specifications

Piston speed	5 to 50 mm/s
Dimensions	Same as standard type
Additional specifications	Same as standard type

Warning Precautions

Be aware that smoking cigarettes etc. after your hands have come into contact with the grease used in this cylinder can create a gas that is hazardous to humans.

5 Special Port Location

Symbol
-XC3

Compared with the standard type, a cylinder which changes the connection port location of rod/head cover.

Applicable Series

Description	Model	Action	Note
Standard type	CJ2	Double acting, Single rod	Except with rail mounting type auto switches, with air cushion
Non-rotating rod type	CJ2K	Double acting, Single rod	Except with rail mounting type auto switches

How to Order

Standard model no.	-XC3	A	B
--------------------	------	---	---

Special port location

Rod port location viewed from the rod side ● Head port location viewed from the rod side ●

* For port location, refer to the diagrams on the right and show the symbols of A, B, C and D.

Specifications: Same as standard type

Port Location

Corresponding symbol of mounting bracket (Positional relationships)	
	* Viewed from the rod side, the ports are rendered A, B, C, and D, in the clockwise direction.
	<Position relation between clevis and rod> * Viewed from the rod side, with the clevis positioned as shown in the diagram, the ports are rendered A, B, C, and D, in the clockwise direction.

6 Adjustable Stroke Cylinder/Adjustable Extension Type

Symbol
-XC8

It adjusts the extending stroke by the stroke adjustable mechanism equipped in the head side. (After the stroke is adjusted, with cushion on both sides is altered to single-sided, with cushion.)

Applicable Series

Description	Model	Action	Note
Standard type	CJ2	Double acting, Single rod	Except with air cushion, double-side bossed, double clevis, double foot, head flange.

How to Order

Standard model no.	-XC8
--------------------	------

Adjustable stroke cylinder/
Adjustable extension type

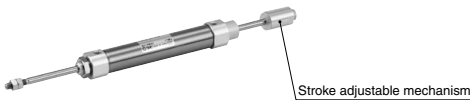

Specifications

Stroke adjustment symbol	—
Stroke adjustment range (mm)	0 to 15
Additional specifications	Same as standard type

Warning Precautions

- When the cylinder is operating, if something gets caught between the stopper bracket for adjusting the stroke and the cylinder body, it could cause bodily injury or damage the peripheral equipment. Therefore, take preventive measures as necessary, such as installing a protective cover.
- To adjust the stroke, make sure to secure the wrench flats of the stopper bracket by a wrench etc. before loosening the lock nut. If the lock nut is loosened without securing the stopper bracket, be aware that the area that joins the load to the piston rod or the area in which the piston rod is joined with the load side and the stopper bracket side could loosen first. It may cause an accident or malfunction.

Dimensions (Dimensions other than below are the same as standard type.)

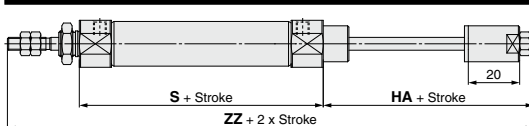

Bore size	Applicable stroke	HA	S	ZZ
10	15 to 150	37	49	114
16	15 to 200	37	50	115

* Dimensions except mentioned above are the same as standard type.

Symbol
-XC9

7 Adjustable Stroke Cylinder/Adjustable Retraction Type

The retracting stroke of the cylinder can be adjusted by the adjusting bolt.

Applicable Series

Description	Model	Action	Note
Standard type	CJ2	Double acting, Single rod	Except double-side bossed, double clevis, double foot, head flange.
Non-rotating rod type	CJ2K	Double acting, Single rod	Except double-side bossed, double clevis, double foot, head flange.
Direct mount type	CJ2R	Double acting, Single rod	
Direct mount, Non-rotating rod type	CJ2RK	Double acting, Single rod	

How to Order

Standard model no. **- XC9**

Adjustable stroke cylinder/
Adjustable retraction type



Specifications

Stroke adjustment symbol	—
Stroke adjustment range (mm)	0 to 15
Additional specifications	Same as standard type

Caution

Precautions

- When air is supplied to the cylinder, if the stroke adjusting bolt is loosened in excess of the allowable stroke adjustment amount, be aware that the stroke adjusting bolt could fly out or air could be discharged, which could injure personnel or damage the peripheral equipment.
- Adjust the stroke when the cylinder is not pressurized. If it is adjusted in the pressurized state, the seal of the adjustment section could become deformed, leading to air leakage.

Dimensions (Dimensions other than below are the same as standard type.)

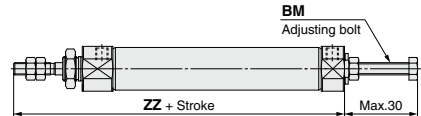

Bore size	BM	ZZ
10	M5 x 0.8	74
16	M5 x 0.8	75

* Dimensions except mentioned above are the same as standard type.

8 Dual Stroke Cylinder/Double Rod Type

Symbol
-XC10

Two cylinders are constructed as one cylinder in a back-to-back configuration allowing the cylinder stroke to be controlled in three steps.

Applicable Series

Description	Model	Action	Note
Standard type	CJ2	Double acting, Single rod	Except with air cushion, rod end bracket and pivot bracket
Non-rotating rod type	CJ2K	Double acting, Single rod	Except rod end bracket and pivot bracket

How to Order

CJ2 [Mounting style] [Bore size] - [Stroke A] + [Stroke B] Z - XC10

Dual stroke cylinder/Double rod type

Dimensions (Dimensions other than below are the same as standard type.)

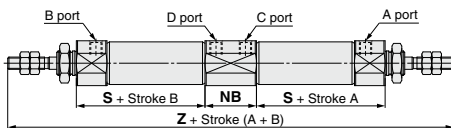

Bore size	NB	S	Z
10	21	36.5	150
16	21	37.5	152

Specifications

Maximum manufacturable stroke (mm)	300 (Maximum 150 on one side)
Additional specifications	Same as standard type



Function

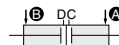

When air pressure is supplied to ports ② and ③, both strokes A and B retract.



When air pressure is supplied to ports ③ and ④, A out strokes.

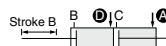

When air pressure is supplied to ports ④ and ⑤, B out strokes.

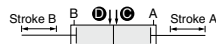

When air pressure is supplied to ports ⑤ and ⑥, both strokes A and B out strokes.

Air Cylinders

CJ2

CM2

CG1

MB

CA2

CQ2

CQS

Lube-retainer

JA

MXH

MXQ

MGP

CQY

CQX

CK01

C(L)K□

C(L)KU

CKQ

CKZ2N

WRF

9 Dual Stroke Cylinder/Single Rod Type

Symbol
-XC11

Two cylinders can be integrated by connecting them in line, and the cylinder stroke can be controlled in two stages in both directions.

Applicable Series

Description	Model	Action	Note
Standard type	CJ2	Double acting, Single rod	Except with air cushion

Specifications: Same as standard type

* Please contact SMC for each manufacturable stroke length.



How to Order

CJ2 **Mounting style** **Bore size** - **Stroke A** + **Stroke B - A** Z - **Pivot bracket** **Rod end bracket** - **XC11**
Dual stroke cylinder/Single rod type

Caution Precautions

1. Do not supply air until the cylinder is fixed.
2. If air is supplied without securing the cylinder, the cylinder could lurch, posing the risk of bodily injury or damage to the peripheral equipment.

Dimensions (Dimensions other than below are the same as standard type.)

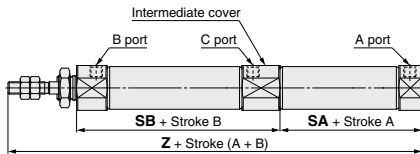

(mm)			
Bore size	SA	SB	Z
10	31.5	53	112.5
16	33	53	114

* Dimensions except mentioned above are the same as standard type.

Note 1) When mounting an auto switch at the extended piston rod A side, the following auto switches interfere with the intermediate cover. In this case, please mount on the stroke B side. Please be aware that the auto switch defects and temporarily turns ON/OFF when passing the intermediate position of the B stroke.

Solid state auto switch: D-H7□, D-H7C, D-H7□W, D-H7NF, D-H7BA

Reed auto switch: D-C7□, D-C80, D-C73C, D-C80C, D-A80, D-A9□, D-A9□V, D-A79W, D-A73

Note 2) The maximum manufacturable stroke of this cylinder is 150 mm for both A and B.

Functional description of dual stroke cylinder

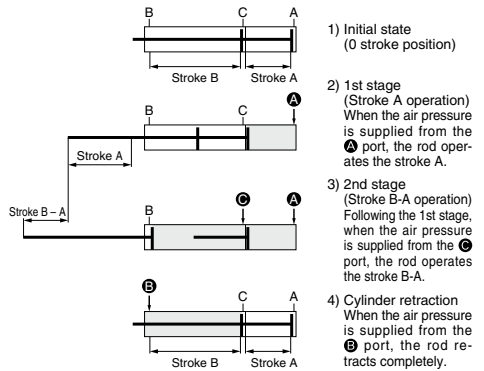

Stroke A or Stroke B operation can be made individually.

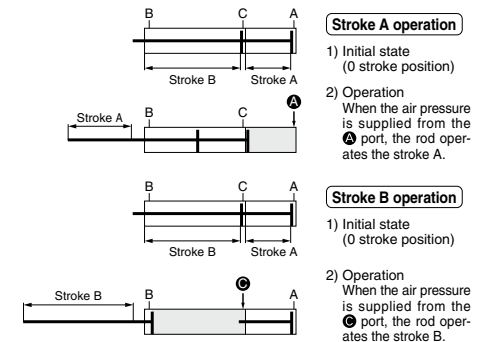

Double output is possible.

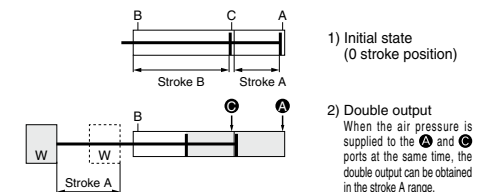

10 Fluororubber Seal

Symbol
-XC22

Applicable Series

Description	Model	Action	Note
Standard type	CJ2	Double acting, Single rod Single acting (Spring return/extend)	Except with air cushion
	CJ2W	Double acting, Double rod	Except with air cushion
Non-rotating rod type	CJ2K	Double acting, Single rod	
Direct mount type	CJ2R	Double acting, Single rod	

How to Order

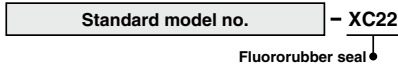

Specifications

Seal material	Fluororubber
Ambient temperature range	With auto switch ^{Note 1)} : -10°C to 60°C Without auto switch : -10°C to 70°C (No freezing)
Specifications other than above and external dimensions	Same as standard type

Note 1) Please contact SMC, as the type of chemical and the operating temperature may not allow the use of this product.

Note 2) Cylinders with auto switches can also be produced; however, auto switch related parts (auto switch units, mounting brackets, built-in magnets) are the same as standard products. Before using these, please contact SMC regarding their suitability for the operating environment.

11 With Hose Nipple

Symbol
-XC51

The one with hose nipple attached in order to save time for assembly at the time of shipment.

Applicable Series

Description	Model	Action	Note
Standard type	CJ2	Double acting, Single rod Single acting (Spring return/extend)	
	CJ2W	Double acting, Double rod	
Non-rotating rod type	CJ2K	Double acting, Single rod Single acting (Spring return/extend)	
	CJ2Z	Double acting, Single rod	
Built-in speed controller type	CJ2Z	Double acting, Single rod	
	CJ2ZW	Double acting, Double rod	
Direct mount type	CJ2R	Double acting, Single rod Single acting (Spring return/extend)	
	CJ2RK	Double acting, Single rod Single acting (Spring return/extend)	

How to Order

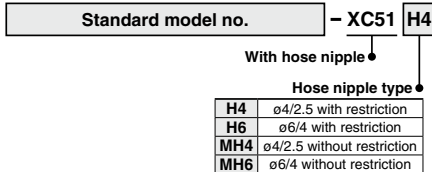

Specifications: Same as standard type

Applicable Hose Nipple Type

Symbol	Applicable bore size (mm)	Function	Hose nipple part no.
H4	ø4/2.5	With a fixed orifice (ø0.8)	CJ-5H-4
H6	ø6/4		CJ-5H-6
MH4	ø4/2.5	Without fixed orifice	M-5H-4
MH6	ø6/4		M-5H-6

Dimensions (Dimensions other than below are the same as standard type.)

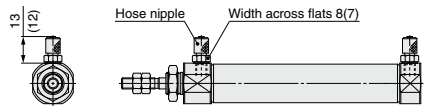

* The above figure shows the ø6/4 hose nipple mounting dimensions. The dimensions in () show those for the ø4/2.5 hose nipple.

Air Cylinders

CJ2

CM2

CG1

MB

CA2

CQ2

CQS

Lube-retainer

JA

MXH

MXQ

MGP

CY

CX

CK1

CL

CL

CL

CL

CKQ

CKZ

CKZ

WRF

INDEX

12 Grease for Food Processing Equipment

Symbol
-XC85

Food grade grease (certified by NSF-H1) is used as lubricant.

Applicable Series

Description	Model	Action	Note
Standard type	CJ2	Double acting, Single rod	
		Single acting (Spring return/extend)	
Non-rotating rod type	CJ2W	Double acting, Double rod	
		Double acting, Single rod	
Built-in speed controller type	CJ2Z	Double acting, Single rod	
		Double acting, Double rod	
Direct mount type	CJ2R	Double acting, Single rod	
		Single acting (Spring return/extend)	
Direct mount, Non-rotating rod type	CJ2RK	Double acting, Single rod	
		Single acting (Spring return/extend)	

How to Order

Standard model no. **- XC85**

Grease for food processing equipment

Warning Precautions

Be aware that smoking cigarettes etc. after your hands have come into contact with the grease used in this cylinder can create a gas that is hazardous to humans.

Not installable zone

Food zone.....An environment where the raw materials and materials of food products, semi-finished food products and food products that make direct or indirect contact in a normal processing process.

Splash zone.....An area where a portion of food products accidentally splash and stick under the intended operating conditions. An environment where food products that enter this area do not return to the food product contact portion again, and are not used as food products.

Installable zone

Non-food zone...Other environments including the food splash zone, except for the food contact portions.

Specifications

Ambient temperature range	With auto switch : -10°C to 60°C (No freezing) Without auto switch : -10°C to 70°C
Seals material	Nitrile rubber
Grease	Grease for food
Auto switch	Mountable
Dimensions	Same as standard type
Specifications other than above	Same as standard type

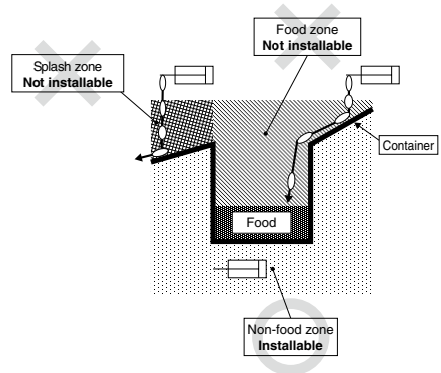

Note 1) Avoid using this product in the food zone.
(Refer to the figure above.)

Note 2) When the product is used in an area of liquid splash, or a water resistant function is required for the product, please consult with SMC.

Note 3) Operate without lubrication from a pneumatic system lubricator.

Note 4) Use the following grease pack for the maintenance work.

GR-H-010 (Grease: 10 g)

Note 5) Please contact SMC for details on the maintenance intervals for this cylinder, which differ from those of the standard cylinder.

13 PTFE Grease

Symbol
-X446

Applicable Series

Description	Model	Action	Note
Standard type	CJ2	Double acting, Single rod	
		Single acting (Spring return/extend)	
Non-rotating rod type	CJ2W	Double acting, Double rod	
		Double acting, Single rod	
Built-in speed controller type	CJ2Z	Double acting, Single rod	
		Double acting, Double rod	
Direct mount type	CJ2R	Double acting, Single rod	
		Single acting (Spring return/extend)	
Direct mount, Non-rotating rod type	CJ2RK	Double acting, Single rod	
		Single acting (Spring return/extend)	

How to Order

Standard model no. **- X446**

PTFE grease

Specifications: Same as standard type

Dimensions: Same as standard type

* When grease is necessary for maintenance, grease pack is available, please order it separately.

GR-F-005 (Grease: 5 g)

Warning Precautions

Be aware that smoking cigarettes etc. after your hands have come into contact with the grease used in this cylinder can create a gas that is hazardous to humans.

Symbol
-X773

14 Short Pitch Mounting/Single Acting, Spring Return

Mounting pitch is shortened when cylinders are used in parallel.

- Changes rod cover and head cover dimensions to $\phi 7$.
- Shortens the full length with a head cover integrated with a barb fitting.

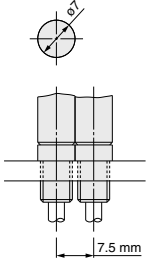

Note) Directly mounted with cylinder mounting screws

Application example

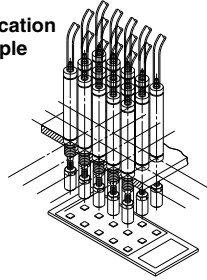

Verification of push button actuation for mobile phones, etc.

Applicable Series

Description	Model	Action	Note
Standard type	CJ2	Single acting (Spring return)	

How to Order

CJ2B6 - **Stroke** SU4 - **X773**

- Short pitch mounting/
Single acting, spring return



Specifications

Bore size	6
Action	Single acting, Spring return
Operating pressure range	0.2 to 0.7 MPa
Port size	With $\phi 4$ barb fitting (For soft tube)
Connecting port location	Head cover/Axial direction
Stroke	5 to 60
Auto switch	None

Dimensions

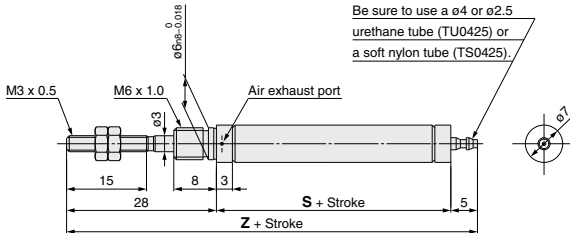

	(mm)			
Stroke	5 to 15	16 to 30	31 to 45	46 to 60
S	30.5	39.5	43.5	57.5
Z	63.5	72.5	76.5	90.5

Note

1. When mounting a cylinder, make sure that the air exhaust port on the rod cover is not blocked.
2. When mounting a cylinder, apply thread locking adhesive on the threaded part and hold the external diameter of the rod cover with a needle-nose pliers or regular pliers.

Air Cylinders

CJ2

CM2

CG1

MB

CA2

CQ2

CQS

Lube-
retainer

JA

MXH

MXQ

MGP

CY

CX

CK1

CK

CKU

CKQ

CKZN

WRF

INDEX

Specific Product Precautions



Be sure to read this before handling. Refer to page 1574 for Safety Instructions. For Actuator and Auto Switch Precautions, refer to “Handling Precautions for SMC Products” and the Operation Manual on SMC website, <http://www.smcworld.com>

Mounting

⚠ Warning

1. Use within the specified cylinder speed and kinetic energy ranges.

Otherwise, cylinder and seal damage may occur.

2. Do not apply excessive lateral load to the piston rod.

Easy checking method

Minimum operating pressure after the cylinder is mounted to the equipment (MPa) = Minimum operating pressure of cylinder (MPa) + {Load weight (kg) x Friction coefficient of guide/Sectional area of cylinder (mm²)}

If smooth operation is confirmed within the above value, the load on the cylinder is the resistance of the thrust only and it can be judged as having no lateral load.

⚠ Caution

1. During installation, secure the rod cover and tighten by applying an appropriate tightening force to the retaining nut or to the rod cover body.

If the head cover is secured or the head cover is tightened, the cover could rotate, leading to the deviation.

2. Tighten the retaining screws to an appropriate tightening torque within the range given below.

ø10: 5.9 to 6.4 N·m, ø16: 10.8 to 11.8 N·m

3. To remove and install the retaining ring for the knuckle pin or the clevis pin, use an appropriate pair of pliers (tool for installing a type C retaining ring). In particular, use a pair of ultra-mini pliers for removing and installing the retaining ring on the ø10 cylinder.

4. In the case of auto switch rail mounting type, do not remove the rail that is mounted. Because retaining screws extend into the cylinder, this could lead to an air leak.

5. Please contact SMC when the stroke exceeds 100 mm for the axial foot mounting style.

<Precautions on the single acting cylinder>

- 1) Do not operate it in such a way that a load would be applied during the retraction of the piston rod of the spring return style, or during the extension of the piston rod of the spring extend style. The spring that is built into the cylinder provides only enough force to retract the piston rod. Thus, if a load is applied, the piston rod will not be able to retract to the end of the stroke.
- 2) A breather hole is provided in the cover surface. Make sure not to block this hole during installation, as this could lead to a malfunction.

<Precautions on the non-rotating cylinder>

- 1) Tighten the retaining screws to an appropriate tightening torque within the range given below.
ø10: 10.8 to 11.8 N·m, ø16: 20 to 21 N·m
- 2) Do not operate it in such a way that rotational torque would be applied to the piston rod. If rotational torque is applied, the non-rotating guide will become deformed, thus affecting the non-rotating accuracy.

Allowable rotational torque (N·m)	ø10	ø16
	0.02	0.04

- 3) To screw a bracket onto the threaded portion at the tip of the piston rod, make sure to retract the piston rod entirely, and place a wrench over the flat portion of the rod that protrudes. To tighten, take precautions to prevent the tightening torque from being applied to the non-rotating guide.

