

Compact Cylinder with Lock Double Acting, Single Rod Series **CLQ**

ø20, ø25, ø32, ø40, ø50, ø63, ø80, ø100

How to Order

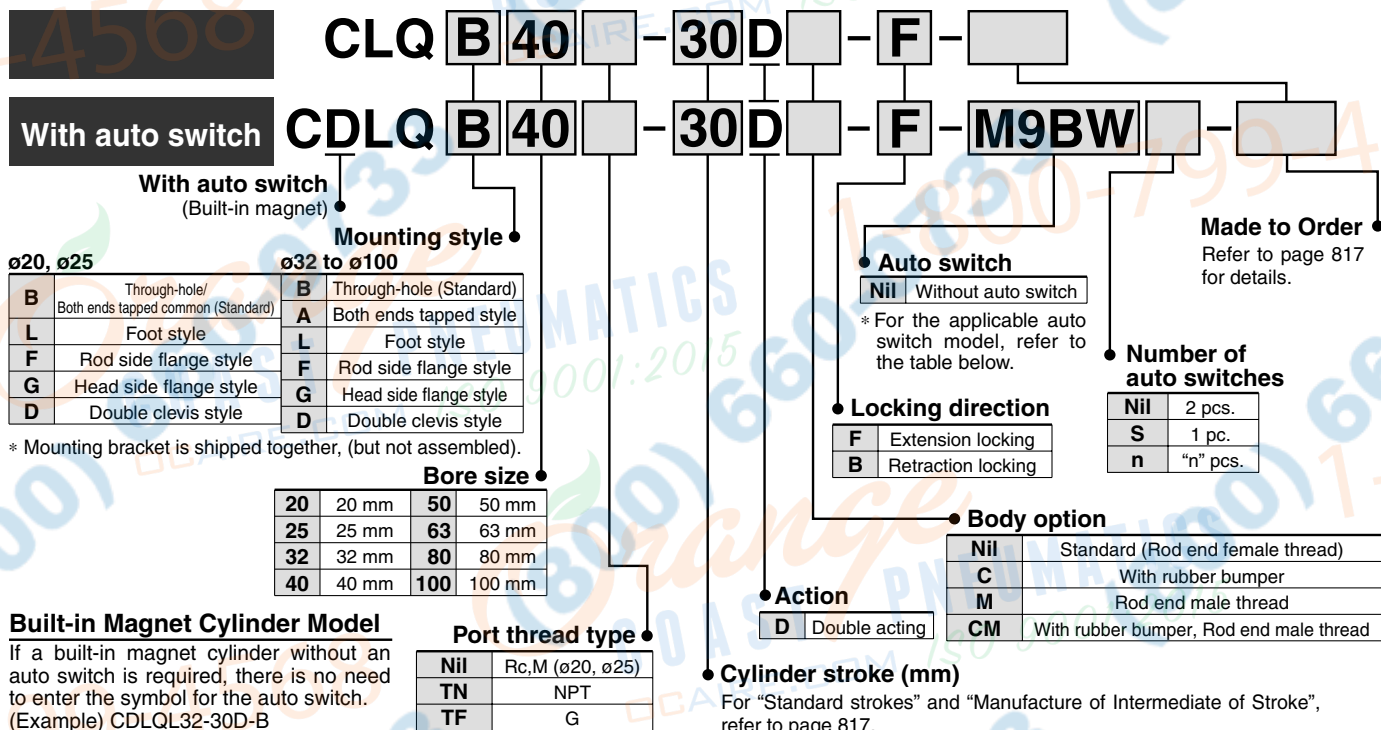

Built-in Magnet Cylinder Model

If a built-in magnet cylinder without an auto switch is required, there is no need to enter the symbol for the auto switch. (Example) CDLQL32-30D-B

Applicable Auto Switch/Refer to pages 1719 to 1827 for detailed specifications of auto switches.

Type	Special function	Electrical entry	Indicator light	Wiring (Output)	Load voltage		Auto switch model		Lead wire length (m)					Pre-wired connector	Applicable load		
					DC	AC	Perpendicular		In-line		0.5 (Nil)	1 (M)	3 (L)			5 (Z)	None (N)
							ø20, ø25	ø32 to ø100	ø20, ø25	ø32 to ø100							
Solid state switch		Grommet	No	3-wire (NPN)	5 V, 12 V		M9NV	M9N	●	●	●	○	—	○	IC circuit		
				3-wire (PNP)			M9PV	M9P	●	●	●	○	—	○			
		Connector	No	2-wire	12V		M9BV	M9B	●	●	●	○	—	○	—		
				—	J79C	—	●	—	●	●	—	—					
	Diagnostic indication (2-color indication)	Grommet	Yes	3-wire (NPN)	5 V, 12 V	24 V	M9NWW	M9NW	●	●	●	○	—	○	IC circuit		
				3-wire (PNP)			M9PWV	M9PW	●	●	●	○	—	○			
		Connector	Yes	2-wire	12 V		M9BWW	M9BW	●	●	●	○	—	○	—		
				3-wire (NPN)	5 V, 12 V		M9NAV	M9NA	○	○	●	○	—	○			
	Water resistant (2-color indication)	Grommet	Yes	3-wire (PNP)	12 V		M9PAV	M9PA	○	○	●	○	—	○	IC circuit		
				2-wire	12 V		M9BAV	M9BA	○	○	●	○	—	○			
With diagnostic output (2-color indication)	Grommet	Yes	4-wire	5 V, 12 V		—	F79F	●	—	●	○	—	○	IC circuit			
			2-wire (Non-polar)	—		—	P4DW	—	—	●	●	—	○				
Reed switch		Grommet	Yes	3-wire (NPN equivalent)	5 V	—	A96V	A96	●	—	●	—	—	—	IC circuit		
				—	200V	—	A72	A72H	●	—	●	—	—				
				12 V	100V	—	A93V	A93	●	—	●	—	—				
		Connector	Yes/None	2-wire	5 V, 12 V	100 V or less	—	A90V	A90	●	—	●	—	—	—	IC circuit	
					12 V	—	—	A73C	—	●	—	●	●	—			
					5 V, 12 V	24 V or less	—	A80C	—	●	—	●	●	—			
Diagnostic indication (2-color indication)	Grommet	Yes/None	2-wire	—	—	—	A79W	—	—	—	—	—	—	—			
				—	—	—	—	—	—	—	—	—	—				

* Lead wire length symbols: 0.5 m Nil (Example) M9NV
1 m M (Example) M9NWM
3 m L (Example) M9NWL
5 m Z (Example) M9NWZ
None N (Example) J79CN

* Solid state auto switches marked with "○" are produced upon receipt of order.
* D-P4DWL is compatible with ø40 to ø100.
* D-P4DW is assembled at the time of shipment.

* Since there are other applicable auto switches than listed, refer to page 837 for details.
* For details about auto switches with pre-wired connector, refer to pages 1784 and 1785.
* When D-A9□(V)/M9□(V)/M9□W(V)/M9□A(V)L types with ø32 to ø50 are mounted on a side other than the port side, order auto switch mounting brackets separately. Refer to page 836 for details.
* When mounting brackets (foot/head side flange/double clevis style) are used, then in some cases auto switches cannot be retrofitted.

Compact Cylinder with Lock Double Acting, Single Rod **Series CLQ**

Cylinder Specifications

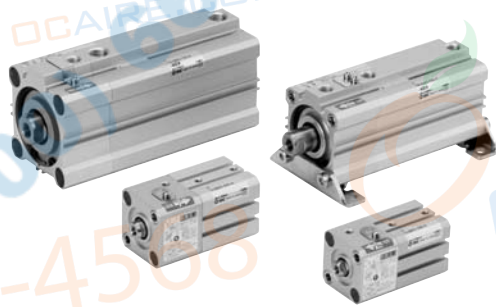

JIS Symbol

Extension locking

Retraction locking

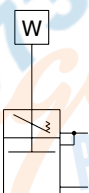
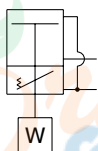

Made to Order Specifications
(For details, refer to pages 1836 and 1926.)

Symbol	Specifications
—XA□	Change of rod end shape
—XC35	With coil scraper (ø40 to ø100 only)

Bore size (mm)	20	25	32	40	50	63	80	100
Action	Double acting, Single rod							
Fluid	Air							
Proof pressure	1.5 MPa							
Maximum operating pressure	1.0 MPa							
Minimum operating pressure	0.2 MPa ^{Note 1)}							
Ambient and fluid temperature	Without auto switch: -10 to 70°C (No freezing) With auto switch: -10 to 60°C (No freezing)							
Lubrication	Non-lube							
Piston speed	50 to 500 mm/s							
Stroke length tolerance	$+1.0$ mm ^{Note 2)}							
Cushion	None, rubber bumper							
Port size (Rc, NPT, G)	M5 x 0.8	1/8		1/4		3/8		

Note 1) The minimum operating pressure of the cylinder is 0.1 MPa when the cylinder and lock are connected to separate ports.

Note 2) Stroke length tolerance does not include the amount of bumper change.

Lock Specifications

Bore size (mm)	20	25	32	40	50	63	80	100
Locking action	Spring locking (Exhaust locking)							
Unlocking pressure	0.2 MPa or more							
Lock starting pressure	0.05 MPa or less							
Locking direction	One direction (Either extension locking or retraction locking)							
Unlocking port size	Rc	M5 x 0.8		1/8		1/4		
	NPT	—		—		—		
	G	—		M5 x 0.8		1/8		1/4
Holding force (N) (Maximum static load)	157	245	402	629	982	1559	2513	3927
	Equivalent to 0.5 MPa							

Note) Be sure to select cylinders referring page 812.

Standard Stroke

Bore size (mm)	Standard stroke (mm)
20, 25	5, 10, 15, 20, 25, 30, 35, 40, 45, 50
32, 40, 50, 63, 80, 100	10, 15, 20, 25, 30, 35, 40, 45, 50, 75, 100

Manufacture of Intermediate Stroke

Description	Spacer is installed in the standard stroke body.	
Part no.	Refer to "How to Order" for the standard model no. on page 816.	
Method	Dealing with the stroke by the 1 mm interval is available by installing spacer with standard stroke cylinder.	
Stroke range	Bore size (mm)	Stroke range (mm)
	20, 25	1 to 50
	32, 40, 50, 63, 80, 100	1 to 100
Example	Part no.: CLQB40-47D-B 3 mm spacer is installed in standard cylinder CLQB40-50D-B. B dimension is 79.5 mm.	

Note) ø40 to ø100 bumper spacers with intermediate strokes can be manufactured in 5 mm increments from 55 to 95 mm.

Refer to pages 834 to 837 for cylinders with auto switches.

- Minimum auto switch mounting stroke
- Proper auto switch mounting position (detection at stroke end) and mounting height
- Operating range
- Switch mounting bracket: Part no.

CLJ2

CLM2

CLG1

CL1

MLGC

CNG

MNB

CNA

CNS

CLS

CLQ

RLQ

MLU

MLGP

ML1C

D-□

-X□

Individual
-X□