

Before Use

Digital Pressure Switch

ZSE20(F)/ISE20



Thank you for purchasing an SMC ZSE20(F)/ISE20 Series Digital Pressure Switch. Please read this manual carefully before operating the product and make sure you understand its capabilities and limitations. Please keep this manual handy for future reference.

To obtain the operation manual about this product and control unit, please refer to the SMC website (URL <http://www.smcworld.com>) or contact SMC directly.

Safety Instructions

These safety instructions are intended to prevent hazardous situations and/or equipment damage. These instructions indicate the level of potential hazard with the labels of "Caution", "Warning" or "Danger". They are all important notes for safety and must be followed in addition to International standards (ISO/IEC) and other safety regulations.

- Caution:** CAUTION indicates a hazard with a low level of risk which, if not avoided, could result in minor or moderate injury.
- Warning:** WARNING indicates a hazard with a medium level of risk which, if not avoided, could result in death or serious injury.
- Danger:** DANGER indicates a hazard with a high level of risk which, if not avoided, will result in death or serious injury.

Operator

- The operation manual is intended for those who have knowledge of machinery using pneumatic equipment, and have sufficient knowledge of assembly, operation and maintenance of such equipment. Only those persons are allowed to perform assembly, operation and maintenance.
- Read and understand the operation manual carefully before assembling, operating or providing maintenance to the product.

Safety Instructions

Warning

- Do not disassemble, modify (including changing the printed circuit board) or repair.** An injury or failure can result.
- Do not operate the product outside of the specifications.** Do not use for flammable or harmful fluids. Fire, malfunction, or damage to the product can result. Verify the specifications before use.
- Do not operate in an atmosphere containing flammable or explosive gases.** Fire or an explosion can result. This product is not designed to be explosion proof.
- Do not use the product in a place where static electricity is a problem.** Otherwise it can cause failure or malfunction of the system.
- If using the product in an interlocking circuit:**
 - Provide a double interlocking system, for example a mechanical system
 - Check the product regularly for proper operation
 - Otherwise malfunction can result, causing an accident.
- The following instructions must be followed during maintenance:**
 - Turn off the power supply
 - Stop the air supply, exhaust the residual pressure and verify that the air is released before performing maintenance work
 - Otherwise an injury can result.

Caution

- Do not touch the terminals and connectors while the power is on.** Otherwise electric shock, malfunction or damage to the product can result.
- After maintenance is complete, perform appropriate functional inspections and leak tests.** Stop operation if the equipment does not function properly or there is a leakage of fluid. When leakage occurs from parts other than the piping, the product might be faulty. Disconnect the power supply and stop the fluid supply. Do not apply fluid under leaking conditions. Safety cannot be assured in the case of unexpected malfunction.

Summary of Product parts

Names of individual parts

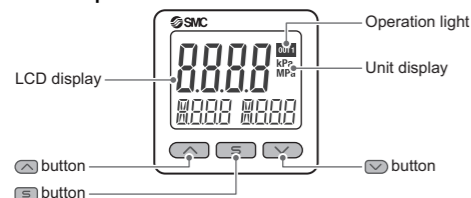

Mounting and Installation

Installation

- Mounting with bracket**
 - Mount the bracket to the body with mounting screws (Self tapping screws: Nominal size 3 x 8L (2 pcs)), then set the body to the specified position.
 - *: Tighten the bracket mounting screws to a torque of 0.5±0.05 Nm. Self tapping screws are used, and should not be re-used several times.

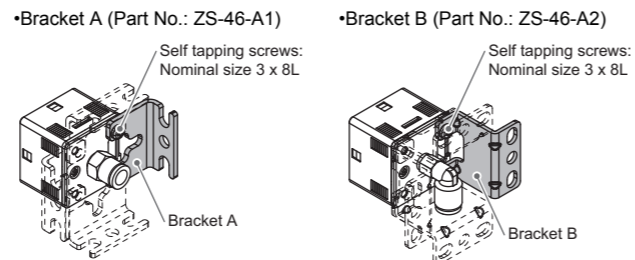

Mounting with panel mount adapter

- Mount part (a) to the front of the body and fix it. Then insert the body with (a) into the panel until (a) comes into contact with the panel front surface. Next, mount part (b) to the body from the rear and insert it until (b) comes into contact with the panel for fixing.
- Panel mount adapter (Part No.: ZS-46-B)
- Panel mount adapter + Front protective cover (Part No.: ZS-46-D)

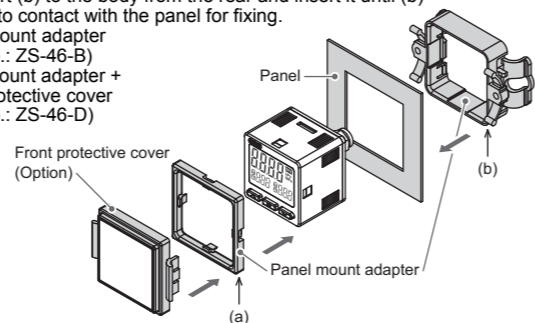

*: The panel mount adapter can be rotated through 90 degrees for mounting.

Refer to the product catalogue or SMC website (URL <http://www.smcworld.com>) for more information about panel cut-out and mounting hole dimensions.

Piping

- Tightening the connection thread**
 - For connecting to the body (piping specification: -M5) After hand tightening, apply a spanner of the correct size to the spanner flats of the piping body, and tighten with a 1/6 to 1/4 rotation. As a reference, the tightening torque is 1 to 1.5 Nm. (When replacing the piping adapter ZS-39-N*, tighten it using the same method.)
 - Piping specification: -01, -N01 After hand tightening, hold the hexagonal spanner flats of the pressure port with a spanner, and tighten with 2 to 3 rotations. As a reference, the tightening torque is 3 to 5 Nm. When tightening, do not hold the Z/ISE20 body with a spanner.

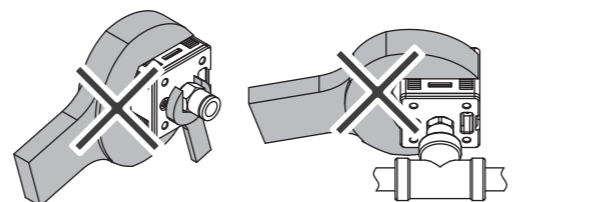

Wiring

- Wiring connections**
 - Connections should be made with the power supply turned off.
 - Use a separate route for the product wiring and any power or high voltage wiring. Otherwise, malfunction may result due to noise.
 - If a commercially available switching power supply is used, be sure to ground the frame ground (FG) terminal. If the switching power supply is connected for use, switching noise will be superimposed and it will not be able to meet the product specifications. In that case, insert a noise filter such as a line noise filter/ferrite between the switching power supplies or change the switching power supply to the series power supply.

How to use connector

- Connector attachment/detachment**
 - When connecting the connector, insert it straight onto the pins, holding the lever and connector body, and lock the connector by pushing the lever hook into the concave groove on the housing.
 - To detach the connector, remove the hook from the groove by pressing the lever downward, and pull the connector straight out.

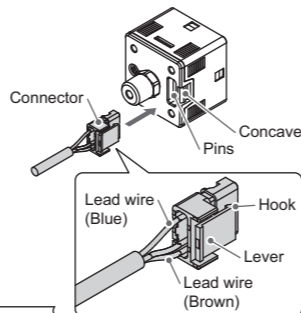

Connector pin numbers

- Pin No.
- DC(+) Brown 5
- OUT1 Black 4
- NC 3
- NC 2
- DC(-) Blue 1

Outline of Settings [Measurement mode]

Power is supplied.

The product code is displayed for approximately 3 sec. after supplying power. *: Within approximately 0.2 second after power-on, the switch starts.

[Measurement mode]

Detects the pressure after power is supplied, and indicates the display and switch operating status. This is the basic mode; other modes should be selected for set-point changes and other function settings.

Measurement mode screen

Current pressure value (Main display)
Item (Sub display (left))
Set value or peak/bottom value (Sub display (right))

Sub display

In measurement mode, the display of the sub display can be temporarily changed by pressing the \leftarrow or \rightarrow buttons.

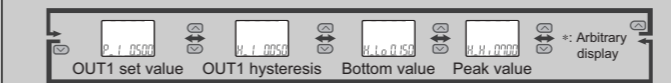

*: One arbitrary display mode can be added to the sub display by setting the [F10] sub display. If the sub display is switched during the arbitrary display setting, the display will be returned to the arbitrary display 30 seconds later. (The default setting does not include arbitrary display.)

- Press the \leftarrow button once.
- Press the \rightarrow button between 1 and 3 sec.
- Press the \rightarrow button between 3 and 5 sec.

- Set either of set value or hysteresis.** (3 step setting mode)
- Select the set value, hysteresis and delay time.** (Simple setting mode)
- Change the function settings.** (Function selection mode)
- Other Settings**
 - *Zero-clear function
 - *Key-lock function

*: The outputs will continue to operate during setting.
*: If a button operation is not performed for 3 seconds during the setting, the display will flash. (This is to prevent the setting from remaining incomplete if, for instance, an operator were to leave during setting.)
*: 3 step setting mode, simple setting mode and function selection mode settings are reflected each other.

Pressure Setting

Default settings

When the pressure exceeds the set value, the switch will be turned on. When the pressure falls below the set value by the amount of hysteresis or more, the switch will be turned off. The default setting is to turn on the pressure switch when the pressure reaches the centre of the atmospheric pressure and upper limit of the rated pressure range. If this condition, shown to the right, is acceptable, then keep these settings.

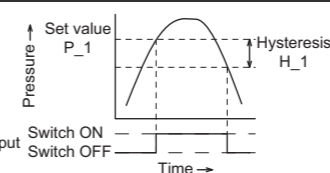

3 Step Setting Mode

[3 step setting mode (hysteresis mode)] In the 3 step setting mode, the set value (P_1 or n_1) and hysteresis (H_1) can be changed. Set the items on the sub display (set value or hysteresis) with \leftarrow or \rightarrow button. When changing the set value, follow the operation below. The hysteresis setting can be changed in the same way.

- Press the \leftarrow button once when the item to be changed is displayed on the sub display. The set value on the sub display (right) will start flashing.
- Press the \leftarrow or \rightarrow button to change the set value. The set value can be increased with \leftarrow button and can be reduced with \rightarrow button. When \leftarrow and \rightarrow buttons are pressed and held simultaneously for 1 second or longer, the set value is displayed as [- -], and the set value will be the same as the current pressure value automatically (snap shot function). Afterwards, it is possible to adjust the value by pressing \leftarrow or \rightarrow button.
- Press the \rightarrow button to complete the setting.

The Pressure switch turns on within a set pressure range (from P1L to P1H) during window comparator mode.

Set P1L, the lower limit of the switch operation, and P1H, the upper limit of the switch operation and WH1 (hysteresis) following the instructions given above. (When reversed output is selected, the sub display (left) shows [n1L] and [n1H].)

*: Setting of the normal/reverse output switching and hysteresis/window comparator mode switching are performed with the function selection mode [F 1] OUT1 setting.

Simple Setting Mode

- Press and hold the \rightarrow button between 1 and 3 seconds in measurement mode. [SET] is displayed on the main display. When the button is released while in the [SET] display, the current pressure value is displayed on the main display, [P_1] or [n_1] is displayed on the sub display (left), and the set value is displayed on the sub display (right) (Flashing).
- Change the set value with \leftarrow or \rightarrow button, and press the \rightarrow button to set the value. Then, the setting moves to hysteresis setting. (The snap shot function can be used.)
- Change the set value with \leftarrow or \rightarrow button, and press the \rightarrow button to set the value. Then, the setting moves to the delay time of the switch output. (The snap shot function can be used.)
- Press the \leftarrow or \rightarrow button, the delay time of the switch output can be selected. Delay time setting can prevent the output from chattering.
- Press the \rightarrow button for 2 seconds or longer to complete the OUT1 setting. *: If the button is pressed for less than 2 seconds, the setting will be returned to P_1.

In the window comparator mode, set P1L, the lower limit of the switch operation, and P1H, the upper limit of the switch operation, WH1 (hysteresis) and dt1 (delay time) following the instructions given above. (When reversed output is selected, the sub display (left) shows [n1L] and [n1H].)

Function Selection Mode

Function selection mode

In measurement mode, press the \rightarrow button between 3 and 5 seconds, to display [F 0]. Select to display the function to be changed [F 0]. Press and hold the button for 2 seconds or longer in function selection mode to return to measurement mode.

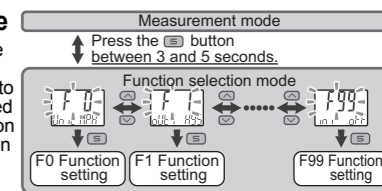

*: Some products do not have all the functions. If no function is available or selected due to configuration of other functions, [- -] is displayed on the sub display (right).

Default setting

The default setting is as follows. If no problem is caused by this setting, keep these settings.

[F 1] Setting of OUT1

Item	Default setting
Output mode	Hysteresis mode
Reversed output	Normal output
Pressure Setting	ISE20 : 0.500 MPa ZSE20 : -50.5 kPa ZSE20F: 50.0 kPa
Hysteresis	ISE20 : 0.050 MPa ZSE20 : 5.1 kPa ZSE20F: 5.0 kPa
Delay time	1.5 ms or less
Display colour	Output ON: Green/Output OFF: Red

Other parameter settings

Item	Default setting	Item	Default setting
[F 2]	No configurable items	[F81] Security code	OFF
[F 3] Digital filter setting	0 ms	[F82] Input of line name	AAAA
[F 4] Auto-preset function	Not used	[F90] Setting of all functions	OFF
[F 5]	No configurable items	[F96]	No configurable items
[F 6] Fine adjustment of display value	0%	[F97]	No configurable items
[F10] Sub display setting	std (Standard)	[F98] Output check	N/A (normal output)
[F11] Display resolution setting	1000-split	[F99] Reset to default settings	OFF
[F80] Power saving mode	OFF		

If you use the product by changing the setting, refer to the SMC website (URL <http://www.smcworld.com>) for more detailed information, or contact SMC.

Other Settings

Peak/bottom value indication

The max. (min.) pressure when the power is supplied is detected and updated. The value can be displayed on the sub display by pressing \leftarrow or \rightarrow button in measurement mode.

Snap shot function

The current pressure value can be stored to the switch output ON/OFF set point. When the set value and hysteresis are set, press the \leftarrow and \rightarrow buttons for 1 second or longer simultaneously. Then, the set value of the sub display (right) shows [- -], and the values corresponding to the current pressure values are automatically displayed.

Zero-clear function

In measurement mode, when the \leftarrow and \rightarrow buttons are pressed for 1 second or longer simultaneously, the main display shows [- -], and the reset to zero. The display returns to measurement mode automatically.

Key-lock function

To set each of these functions, refer to the SMC website (URL <http://www.smcworld.com>) for more detailed information, or contact SMC.

Maintenance

How to reset the product after a power cut or forcible de-energizing

The setting of the product will be retained as it was before a power cut or de-energizing. The output condition is also basically recovered to that before a power cut or de-energizing, but may change depending on the operating environment. Therefore, check the safety of the whole installation before operating the product. If the installation is using accurate control, wait until the product has warmed up (approximately 10 to 15 minutes).

Troubleshooting

Error indication function

This function is to display error location and content when a problem or error has occurred.

Error	Error displayed	Description	Measures
Over current error	Er 1	The switch output load current is 80 mA or more.	Turn the power off and remove the cause of the over current. Then supply the power again.
Residual pressure error	Er 3	During zero clear operation, pressure greater than ±7% F.S. (±3.6% F.S. for compound pressure) is present. Note that the mode is returned to measurement mode automatically 1 second later. The zero clear range varies by ±1% F.S. due to variation between individual products.	Release the applied pressure to atmospheric pressure, and retry the zero clear operation.
Pressurizing error	HHH LLL	Pressure exceeding the upper limit of the set pressure range is applied. Pressure exceeding the lower limit of the set pressure range is applied.	Reset applied pressure to a level within the set pressure range.
System error	Er 0 Er 4 Er 6 Er 7 Er 8 Er 9	Displayed if an internal data error has occurred.	Turn the power off and on again. If the failure cannot be solved, contact SMC.

If the error cannot be reset after the above measures are taken, or errors other than above are displayed, please contact SMC.

Refer to the SMC website (URL <http://www.smcworld.com>) for more information about troubleshooting.

Specifications/Outline with Dimensions (in mm)

Refer to the product catalogue or SMC website (URL <http://www.smcworld.com>) for more information about the product specifications and outline dimensions.

SMC Corporation URL <http://www.smcworld.com>

Akihara UDX 15F, 4-14-1, Sotokanda, Chiyoda-ku, Tokyo 101-0021, JAPAN
Phone: +81 3-5207-8249 Fax: +81 3-5298-5362

Note: Specifications are subject to change without prior notice and any obligation on the part of the manufacturer.
© 2015 SMC Corporation All Rights Reserved PS: *-OMS0008-A