

Separate Controller

Ionizer / Slim Bar Type

New



Powerfully eliminates static electricity from highly charged workpieces

- Pulse AC type, High density emitter arrangement (6 times the number of emitters*1)
- Ideal for removing static electricity from films, resins, etc.

*1 Compared to the existing model

New IZT44/45

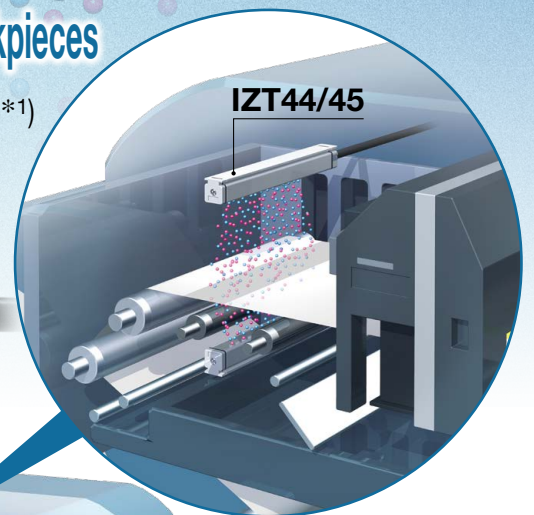

Can be mounted in a narrow space

- Height 23 mm x Width 20 mm

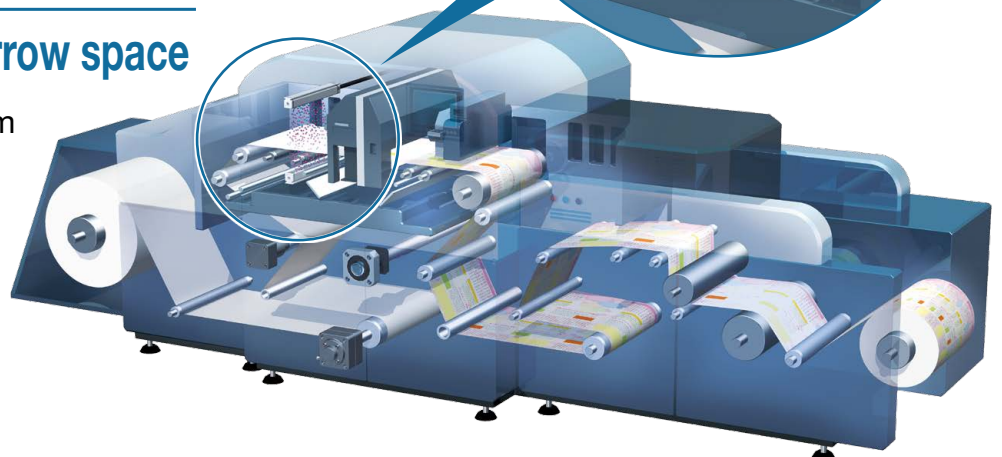

IZT44/45 Series



CAT.ES100-168A

Powerful static elimination Pulse AC type, High density emitter arrangement (6 times the number of emitters*1)

*1 Compared to the existing model

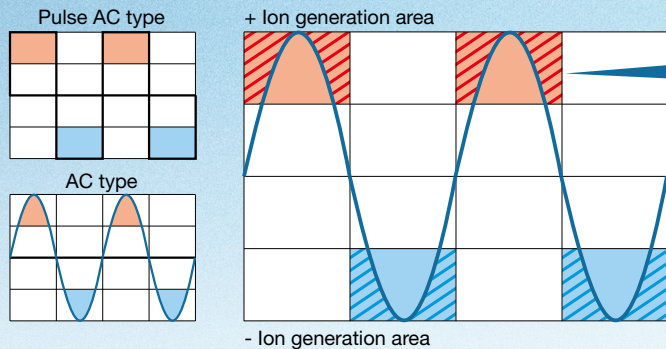

High density emitter arrangement

	Pitch [mm]	Number of emitters
New IZT44/45	10	6
IZT40/41	60	1

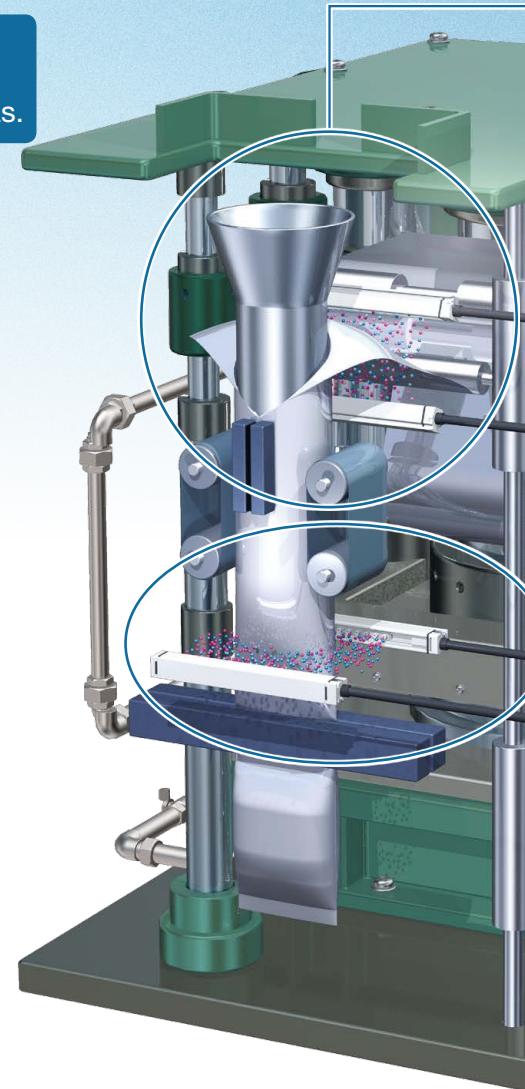
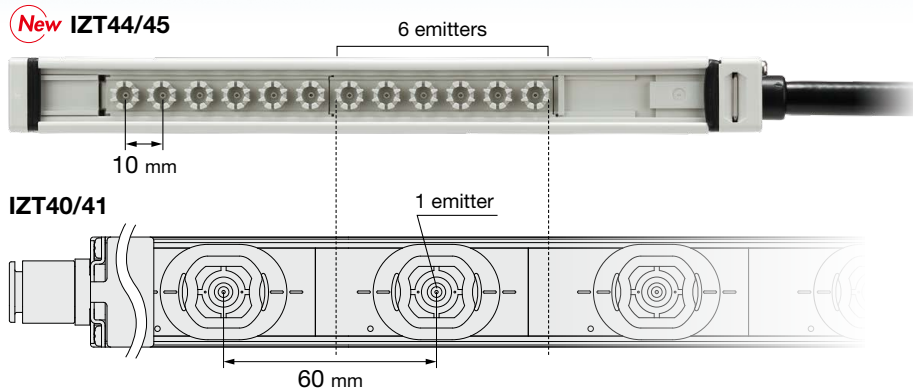

High speed static elimination

Ion generation frequency: 30 Hz, Without air

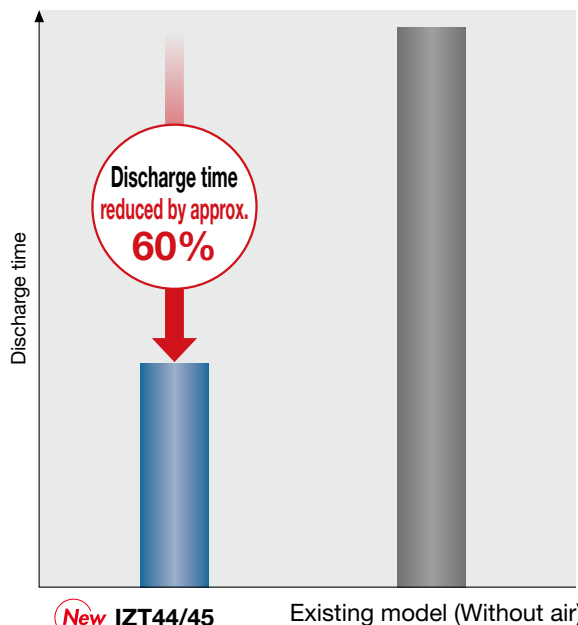

Powerful static elimination is possible without air supply.

Prevents heat sealer temperature deterioration

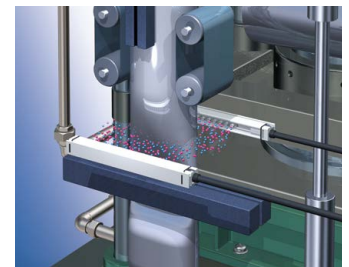

Prevents workpiece from being blown away

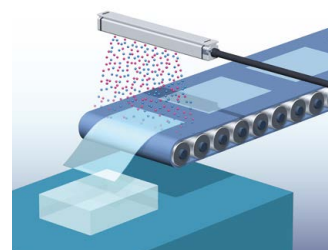

Prevents dust from blowing up

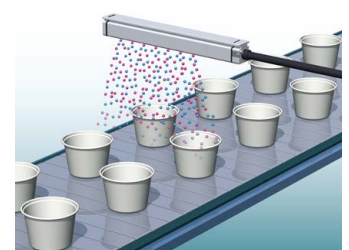

Compact design allows close installation in narrow spaces.

Installation at the film transfer section

Installation near the seal section

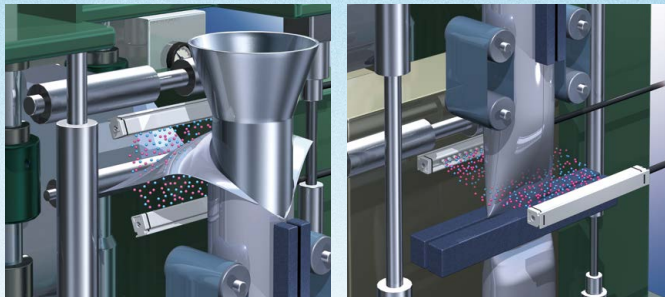

Height: Comparison with the existing model

Existing model IZT40/41

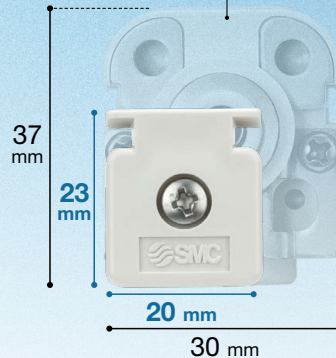

2-way directional static elimination using branch cables

2 ionizer bars can be connected to one high voltage power supply.

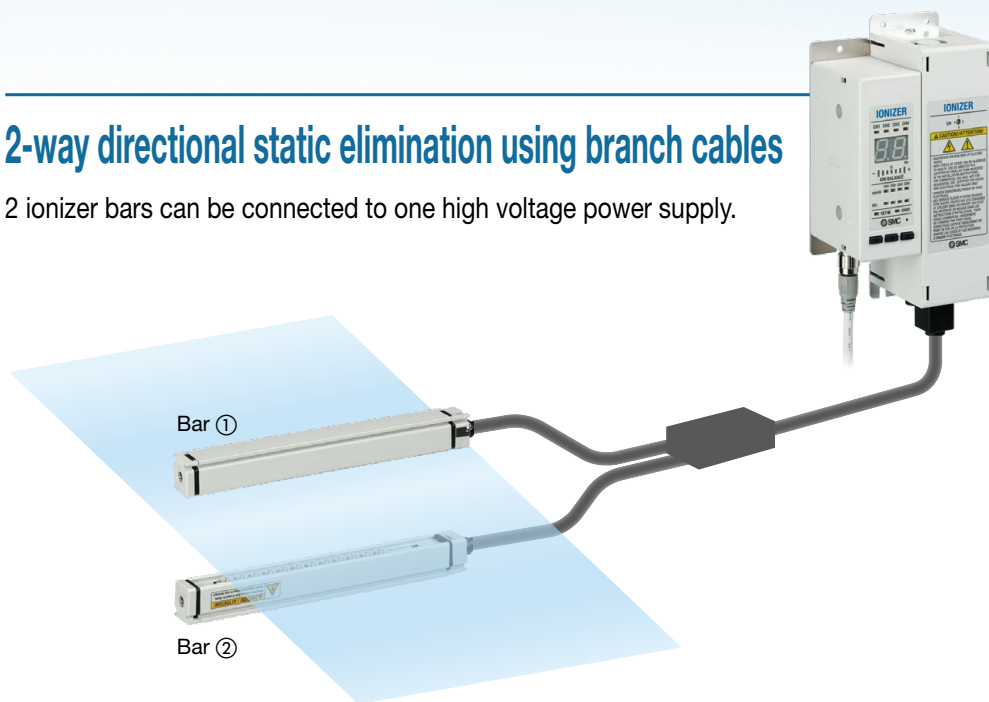

Improved maintainability

• Clean all the emitters with a dedicated cleaning kit.

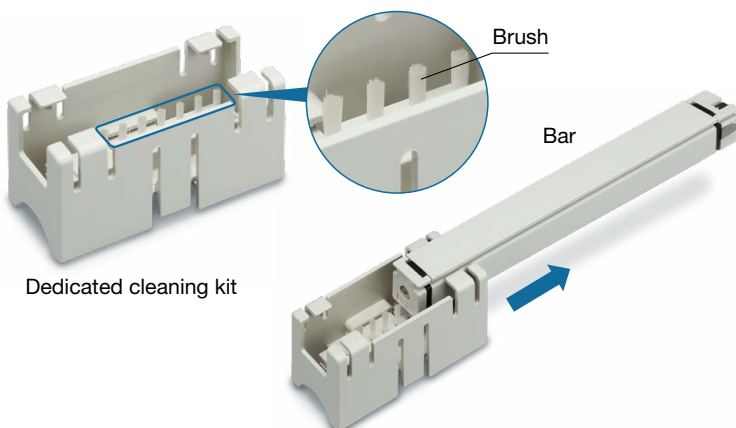

• The bar can be easily replaced. **p. 4**

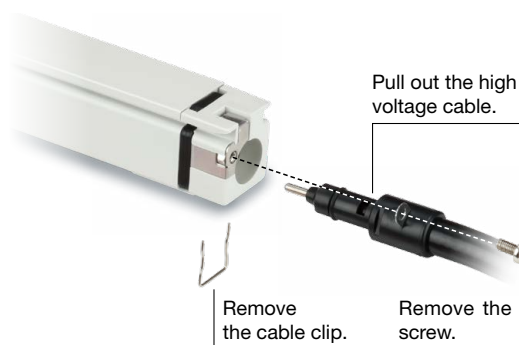

2 types of controllers are available.

Integrated High voltage power supply IZT44 Series

Simple operation

- Ready to use by simply turning on the power supply.
- Space-saving installation
- Error detection indication and output signal

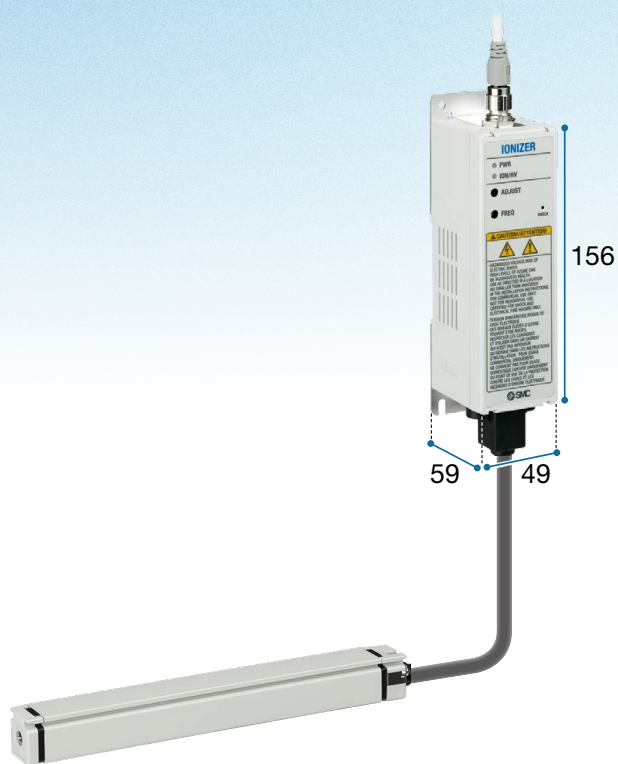

Separate High voltage power supply IZT45 Series

Supports various sensing function.

- Flexible layout by the separation of the controller and the high voltage power supply module
- 4 high voltage power supply modules can be connected
- Error detection indication and output signal

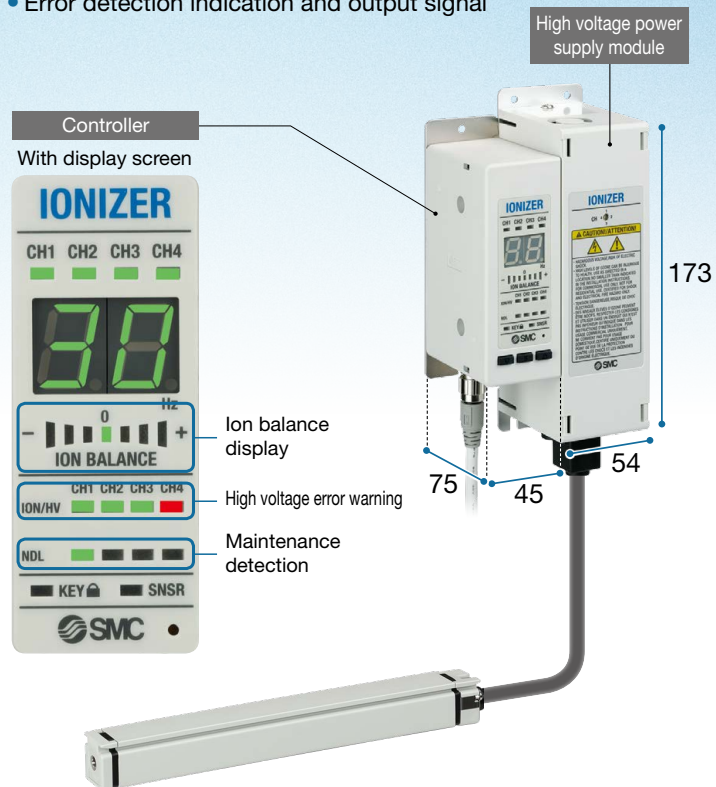

Up to 4 high voltage power supply modules can be connected to one controller.

IZT 45

Centralized control

- Error check
- Dirty emitter check

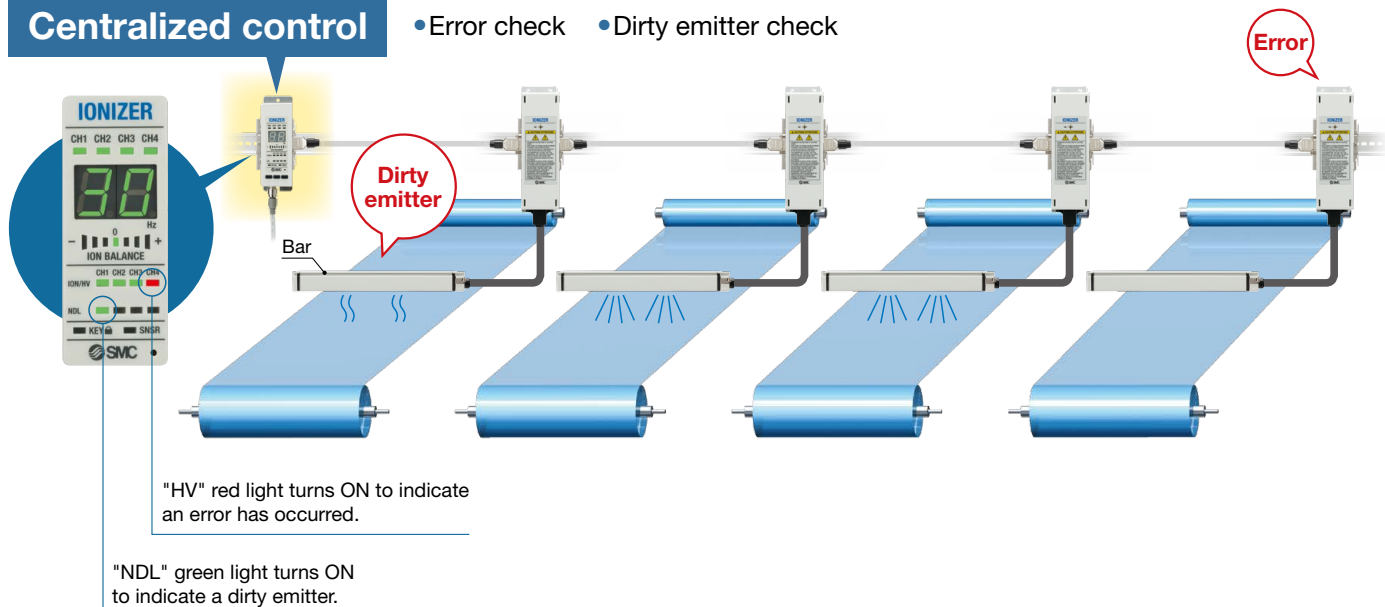

Flexible layout possible with various module connection methods

IZT 45

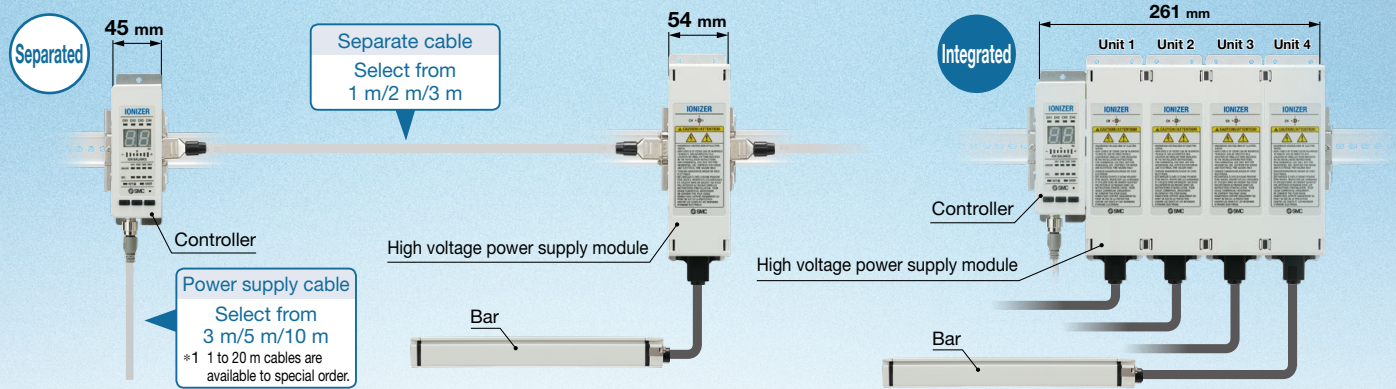

• Controller to Bar maximum installation distance: 15 m

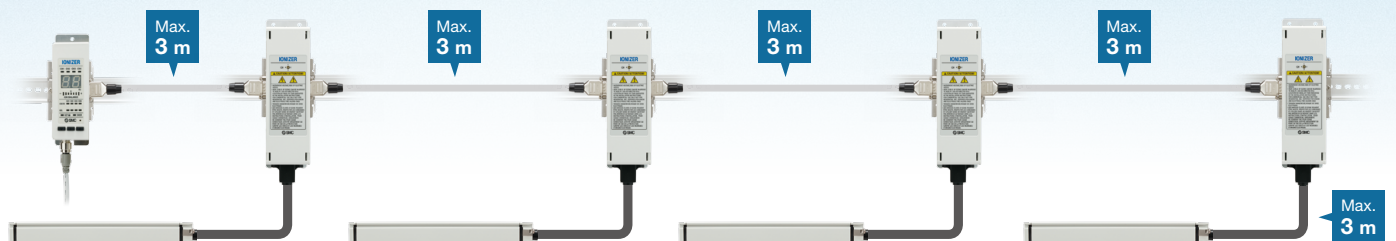

Can be installed through gaps between equipment

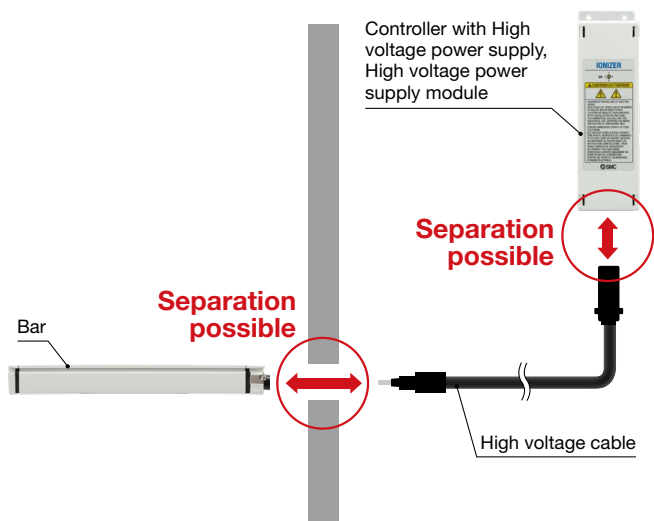

Improved installation, replacement, and maintenance in narrow spaces

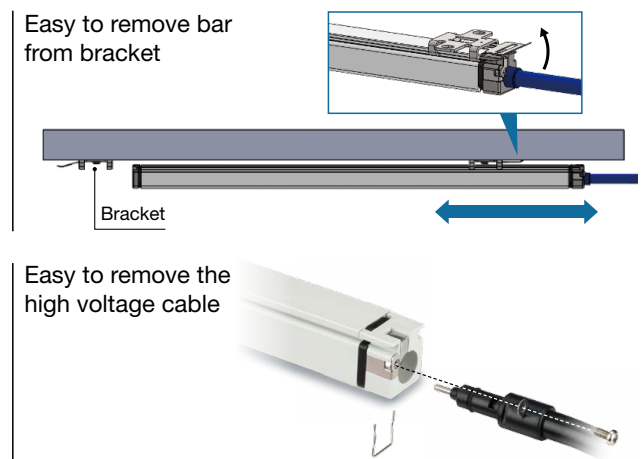

Related Products

Electrostatic Sensor/IZD10 Series

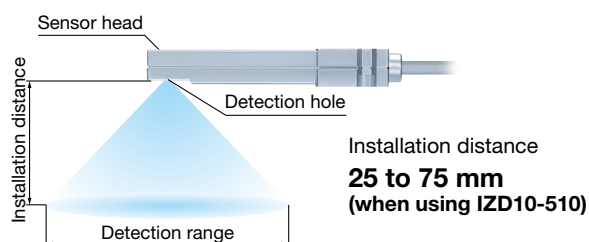

Installation distance and detection range

Installation distance [mm]	25	30	40	50	60	70	75
Detection range [mm]	100	120	150	180	205	225	235

Electrostatic Sensor Monitor/IZE11 Series

2-color display (Red/Green)

[Analog output]
The measured potential is displayed as a waveform.

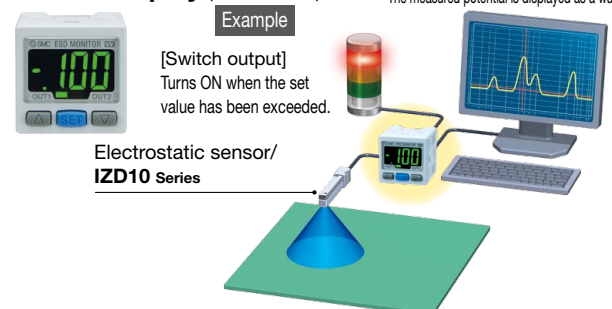











Separate Controller Ionizer / Slim Bar Type IZT44/45 Series

<Functions>

	IZT44	IZT45
Applied voltage method	Pulse AC, DC (either positive or negative)	Pulse AC, DC (either positive or negative)
Auto balance	—	●
Input/Output	● (Output only)	●
Ion balance display	—	●
High voltage error detection	●	●
Maintenance detection	—	●
Ion generation stop signal	—	●
Output check*1	●	●
NPN/PNP switch output	● (Wiring)	● (Controller operation)

*1 The function which provides an output signal arbitrarily in normal operation (For wiring confirmation)

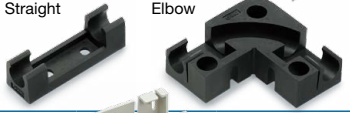
<Accessories, Optional Parts>

Bar bracket p. 12		●	●
DIN rail mounting bracket for Controller and High voltage power supply module p. 12	IZT44 For Controller with High voltage power supply 	●	—
	IZT45 For Controller For High voltage power supply module 	—	●
Power supply cable p. 12	For IZT44 	●	—
	For IZT45 	—	●
AC adapter p. 12	For IZT44 	●	—
	For IZT45	—	●
Separate cable p. 12		—	●
High voltage cable assembly p. 12		●	●
Branch cable assembly p. 12		●	●
High voltage cable holder p. 12	Straight Elbow 	●	●
Cleaning kit p. 12		●	●

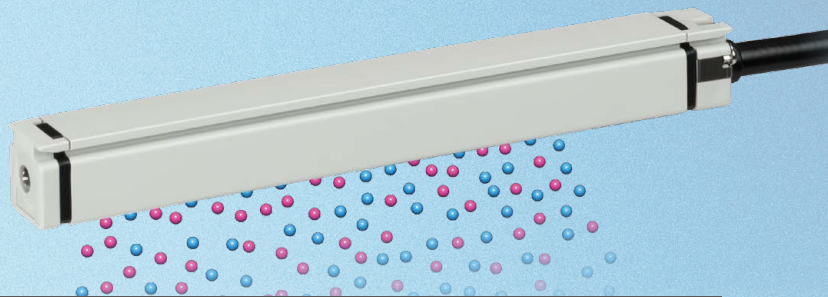

Application Examples

For the film conveyer

- Prevents dust adhesion
- Prevents film winding defects

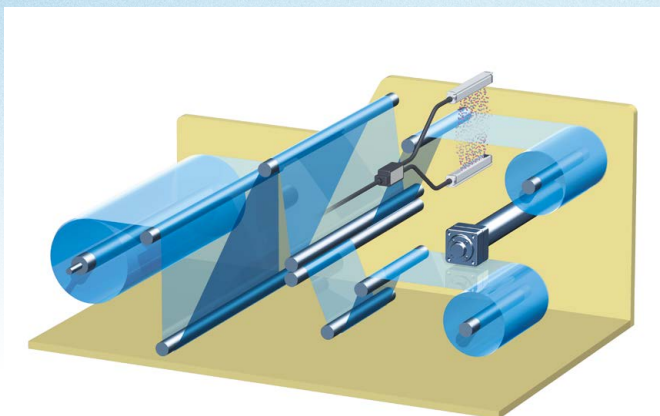

For the film cutting

- Prevents bag sticking and scattering
- Prevents operator discomfort

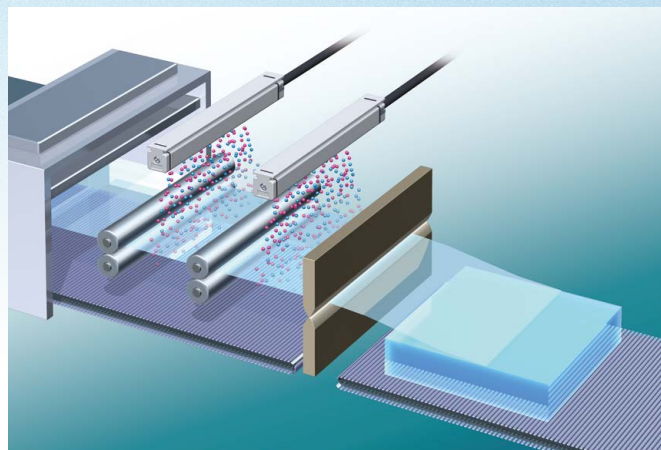

For the PTP / Blister packaging machine

- Prevents tablets from popping out

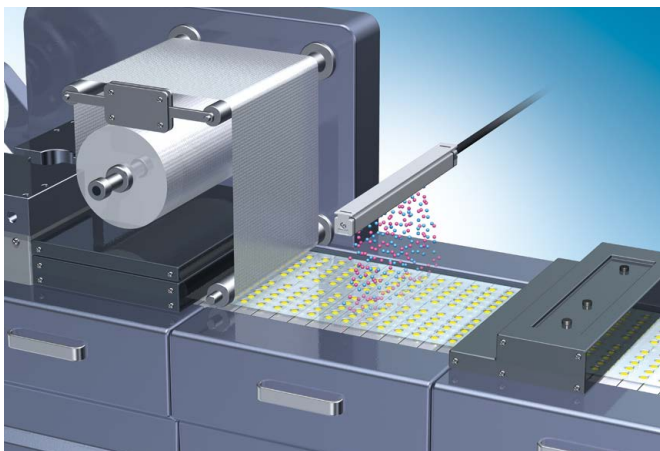

For the static neutralization of cups

- Prevents dust adhesion

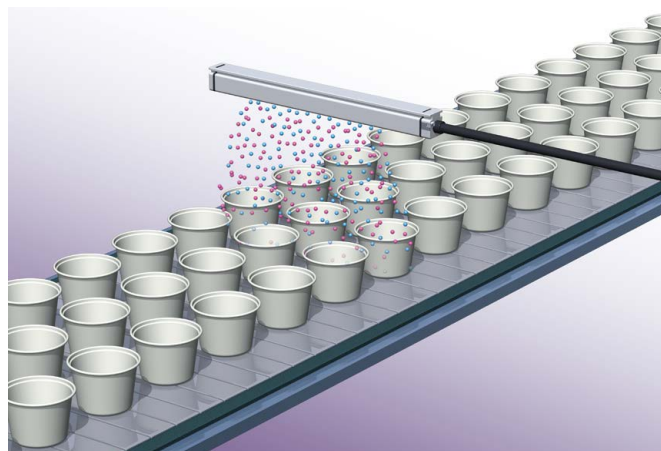

For the label pasting machine

- Prevents dust adhesion
- Prevents incorrect label pasting position

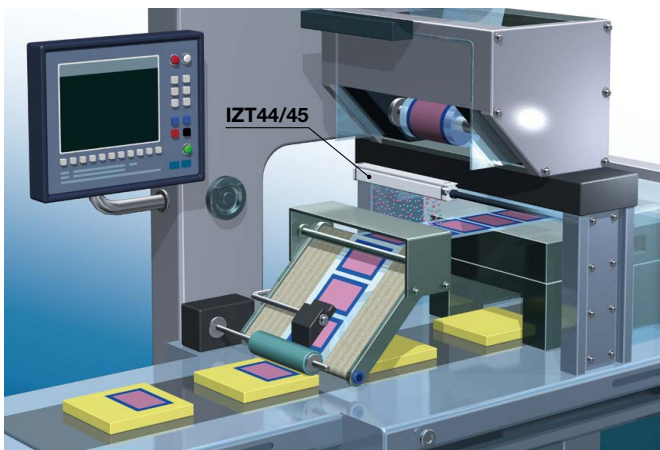

For the rotary printing press

- Prevents poor winding of printed materials

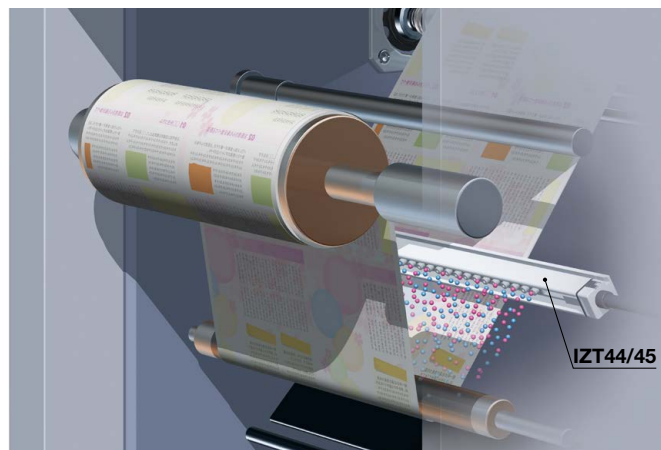

CONTENTS

Separate Controller Ionizer / Slim Bar Type IZT44/45 Series

IZT44 Series



IZT45 Series



Separate Controller

Ionizer / Slim Bar Type IZT44/45 Series

Technical Data	p. 8
How to Order	
Bar + Controller with High voltage power supply	p. 9
Bar + High voltage power supply module + Controller	p. 9
For Individual Parts	p. 10
(Bar/Controller with High voltage power supply/Controller/High voltage power supply module)	
Specifications	p. 11
Accessories (for Individual Parts)	p. 12
Accessories Sold Separately	p. 12
Maintenance Parts	p. 12
Wiring Circuit	p. 13
Dimensions	p. 14
Compatibility with the Existing Products	p. 19

IZT44/45 Series/Precautions

Be sure to read this before handling the products. For the safety instructions, refer to the “Handling Precautions for SMC Products” and the “Operation Manual” found on the SMC website.

IZT44/45 Series

Technical Data

* Static neutralization characteristics are based on data using a charged plate (Dimensions: 150 mm x 150 mm, Capacitance: 20 pF) as defined in the U.S. ANSI standards (ANSI/ESD STM3.1-2015). Use this data only as a guideline for model selection because the values vary depending on the material and/or size of the subject.

Static Neutralization Characteristics

① Installation Distance and Discharge Time (Discharge Time from 1000 V to 100 V)

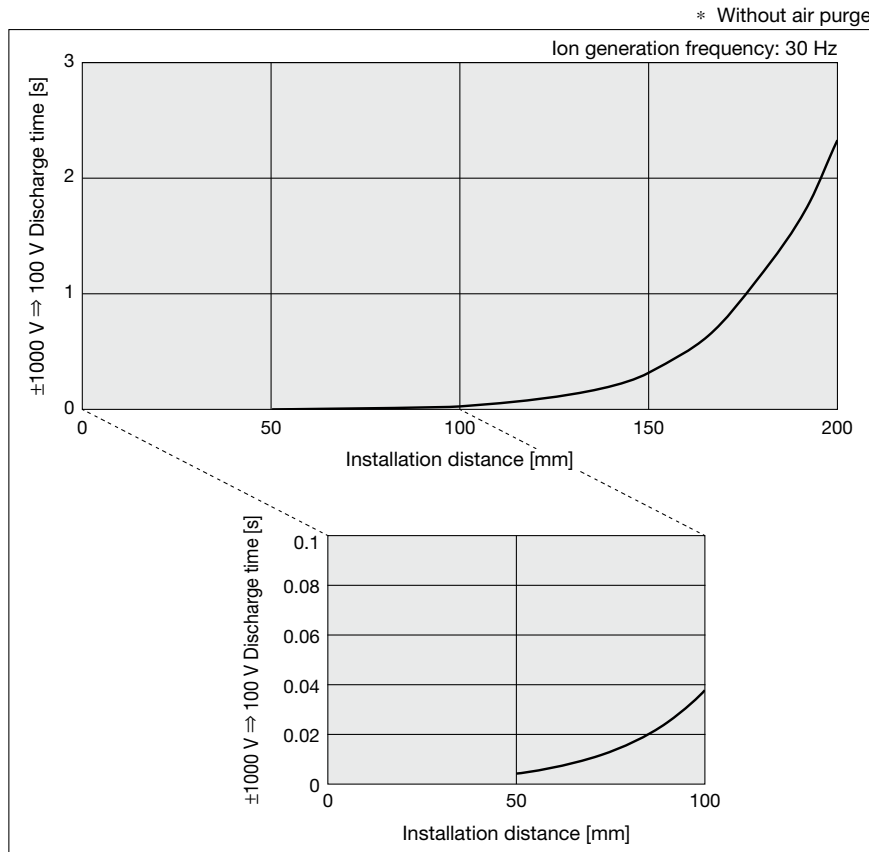

② Change in Electrostatic Charge during Static Neutralization

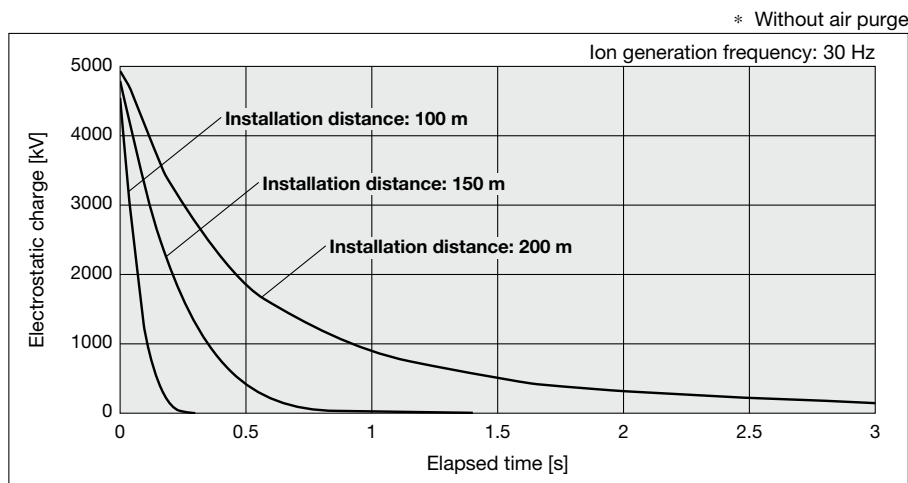

Separate Controller



Ionizer / Slim Bar Type

IZT44/45 Series

How to Order

Bar + Controller with High voltage power supply

IZT44 - 20 - 1 - 3 V

Bar + High voltage power supply module + Controller

IZT45 - 20 - 1 - 3 W

① ② ③ ④

① Bar length

Symbol	Bar length [mm]	Symbol	Bar length [mm]
20	200	56	560
26	260	62	620
32	320	68	680
38	380	74	740
44	440	92	920
50	500	128	1280

* The number of bar brackets included will vary depending on the bar length (see the table below).

Number of included bar brackets

Bar length [mm]	End bracket	Intermediate bracket
200 to 620	2	None
680 to 1280		1

③ Power supply cable length

Symbol	Cable length [m]
3	3
5	5
10	10
N	None

* The power supply cables included with IZT44 and IZT45 are different.
 * When using an AC adapter, select "N" and then select the AC adapter from the items sold separately.

② High voltage cable length

Symbol	Cable length [m]
1	1
2	2
3	3

* The number of included high voltage cable holders differs depending on the high voltage cable length. (Refer to the table below.)

Number of included high voltage cable holders

Symbol	Straight	Elbow
1	1	1
2	2	1
3	3	1

④ DIN rail mounting bracket

For IZT44 Controller with High voltage power supply	
Symbol	For Controller
Nil	None
V	Included

For IZT45 Controller, For High voltage power supply module

Symbol	For Controller	For High voltage power supply module
Nil	None	None
U	Included	Included
W	Included	None
Y	None	Included

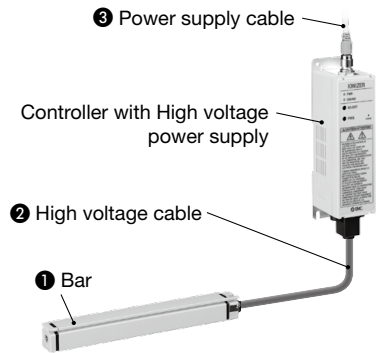

IZT44

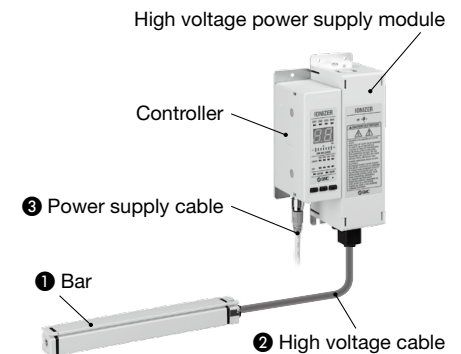

IZT45

For Individual Parts

How to Order

Individual Parts Combinations

	Bar / IZTB44	High voltage power supply module / IZTP41-L	Controller / IZTC	
			44 (with High voltage power supply)	45
IZT44	●		●	
IZT45	●	●		●

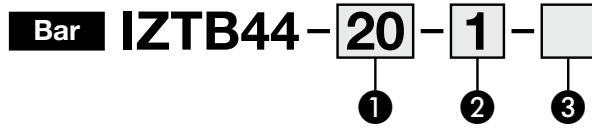

① Bar length

Symbol	Bar length [mm]	Symbol	Bar length [mm]
20	200	56	560
26	260	62	620
32	320	68	680
38	380	74	740
44	440	92	920
50	500	128	1280

② High voltage cable length

Symbol	Cable length [m]
1	1
2	2
3	3
N	None

* The number of included high voltage cable holders differs depending on the high voltage cable length. (Refer to the table below.)

Number of included high voltage cable holders

Symbol	Straight	Elbow
1	1	1
2	2	1
3	3	1

③ Bar bracket

Symbol	For Bar
Nil	None
B	Included

* The number of bar brackets included will vary depending on the bar length (see the table below).

*** Number of included brackets**

Bar length	End bracket	Intermediate bracket
200 to 620		None
680 to 1280	2	1

Controller with High voltage power supply

Controller

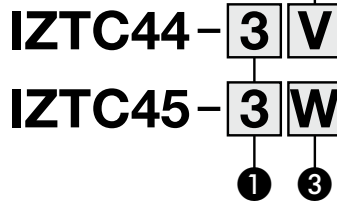

IZTC44



IZTC45

① Power supply cable length

Symbol	Cable length [m]
3	3
5	5
10	10
N	None

* The power supply cables included with IZTC44 and IZTC45 are different.

② DIN rail mounting bracket for IZT44 Controller

Symbol	For Controller
Nil	None
V	Included

③ DIN rail mounting bracket for IZT45 Controller

Symbol	For Controller
Nil	None
W	Included

High voltage power supply module

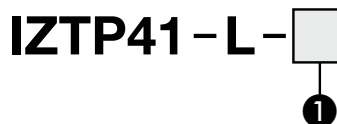

① DIN rail mounting bracket for High voltage power supply module

Symbol	For High voltage power supply module
Nil	None
Y	Included



IZTP41-L

IZT44/45 Series

Specifications

Ionizer model		IZT44	IZT45
Ion generation method		Corona discharge type	
Method of applying voltage		AC, DC*1	
Applied voltage		±7000 V	
Current consumption		0.5 A or less	0.6 A or less (+0.5 A or less per ionizer when connected)
Power supply voltage		24 VDC ±10%	
Switch input	NPN specification *2	—	Voltage range: 5 VDC or less Current consumption: 5 mA or less
	PNP specification *2	—	Voltage range: 19 VDC to power supply voltage Current consumption: 5 mA or less
Switch output (Open collector)	NPN specification *2	Max. load current: 100 mA Residual voltage: 1 V or less (Load current at 100 mA) Max. applied voltage: 26.4 VDC	Max. load current: 100 mA Residual voltage: 1 V or less (Load current at 100 mA) Max. applied voltage: 26.4 VDC
	PNP specification *2	Max. load current: 100 mA Residual voltage: 1 V or less (Load current at 100 mA)	Max. load current: 100 mA Residual voltage: 1 V or less (Load current at 100 mA)
Function		High voltage abnormality detection (Ion generation stops when an abnormality is detected.), Output check	Auto balance, Maintenance detection, High voltage abnormality detection (Ion generation stops when an abnormality is detected.), Ion generation stop, and Output check
Effective static neutralization distance		50 to 200 mm	
Ambient temperature	Controller, High voltage power supply module	0 to 40°C	
	Bar	0 to 50°C	
Ambient humidity		35 to 80%RH (No condensation)	
Material	Controller	Cover: ABS, Aluminum	Cover: ABS, Aluminum Switch: Silicone rubber
	High voltage power supply module		Cover: ABS, Aluminum
	Bar	Cover: ABS, PBT, Emitter: Tungsten High voltage cable: Silicone rubber, PVC	
IP enclosure	Controller	IP20	IP20
	High voltage power supply module		IP20
	Bar	IP40	
Standards		CE (EMC directive, RoHS directive), UKCA	

*1 Apply cathode or anode to DC.

*2 For the IZT44, NPN or PNP can be selected by wiring. For the IZT45, NPN or PNP can be selected by controller operation.

Weight

[g]

	Controller	High voltage power supply module
IZT44	440	
IZT45	220	690

[g]

Bar length [mm]		200	260	320	380	440	500	560	620	680	740	920	1280
IZT44 IZT45 (Common for bars)	High voltage cable (1 m)	250	275	305	330	360	385	415	440	470	495	575	740
	High voltage cable (2 m)	365	395	420	450	475	500	530	555	585	610	690	855
	High voltage cable (3 m)	480	510	535	565	590	620	645	670	700	725	810	970

AC Adapter (Sold Separately)

Model	IZT44-CG1, IZT44-CG2, IZT45-CG1, IZT45-CG2
Input voltage *1	100 to 240 VAC, 50/60 Hz
Output current	1.9 A
Ambient temperature	0 to 40°C
Ambient humidity	35 to 65%RH (No condensation)
Weight	365 g (IZT4□-CG1), 200 g (IZT4□-CG2)
Standards/Directive	CE/UKCA, UL, CSA

*1 The included AC cable is for use in Japan only (Rated voltage 125 V, Plug JIS8303, Inlet IEC60320-C13).

Accessories (for Individual Parts)

Bar bracket

IZT44 - B E

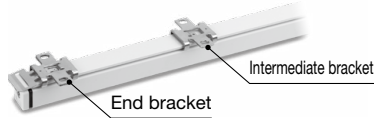

• **Bar bracket**

Symbol	Type
E	End bracket
M	Intermediate bracket

DIN rail mounting bracket for IZT44 Controller with High voltage power supply

IZT44 - B1



DIN rail mounting bracket for IZT45 Controller and High voltage power supply module

IZT40 - B 1

• **DIN rail mounting bracket**

Symbol	Type
1	For Controller
2	For High voltage power supply module



IZT40-B1



IZT40-B2

Power supply cable

IZT44 - CP 3



Power supply cable for IZT44

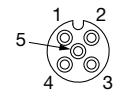

Socket connector pin assignment A-coded (Normal key)

IZT45 - CP 3



Power supply cable for IZT45

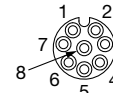

Socket connector pin assignment A-coded (Normal key)

• **Power supply cable length**

Symbol	Cable length [m]
3	3
5	5
10	10

High voltage cable holder

IZT40 - E 1

• **High voltage cable holder**

Symbol	Type
1	Straight
2	Elbow

Straight



IZT40-E1

Elbow



IZT40-E2

Accessories Sold Separately

Branch cable

IZT44 - A001



* Use in combination with the IZTB44-□-N-□.

High voltage cable assembly

IZT43 - A002 - 1



• **High voltage cable length**

Symbol	Cable length [m]
1	1
2	2
3	3

AC adapter

IZT44 - CG 1

IZT45 - CG 1



AC adapter

• **AC cord selection**

Symbol	Type
1	With AC cable
2	Without AC cable

* The included AC cable is for use in Japan only (Rated voltage 125 V, Plug JIS C 8303, Inlet IEC 60320-C6)

* The external input/output function cannot be used when an AC adapter is being used.

Separate cable (For IZT45)

IZT40 - CF 1



• **Separate cable length**

Symbol	Cable length [m]
1	1
2	2
3	3

Maintenance Parts

Cleaning kit

IZT44 - M3



IZT44/45 Series

Wiring Circuit/IZT44, IZT45

IZT44

NPN output

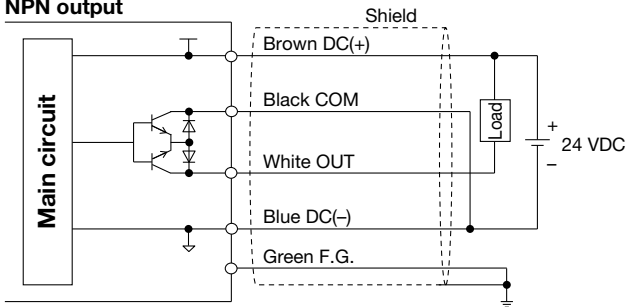

PNP output

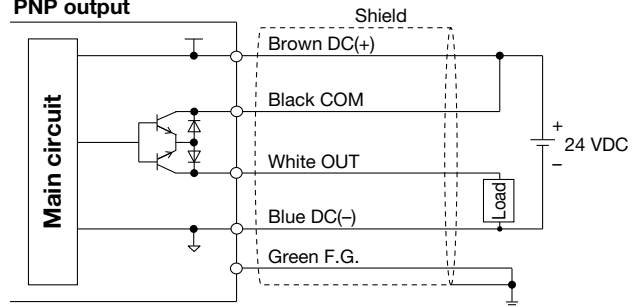

IZT45

NPN setting

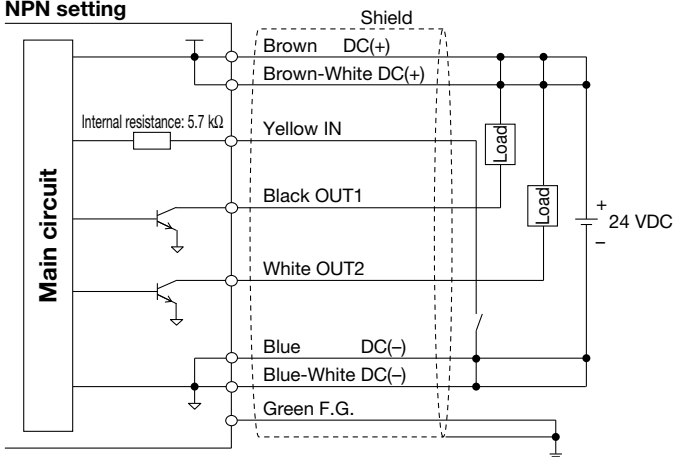

NPN setting

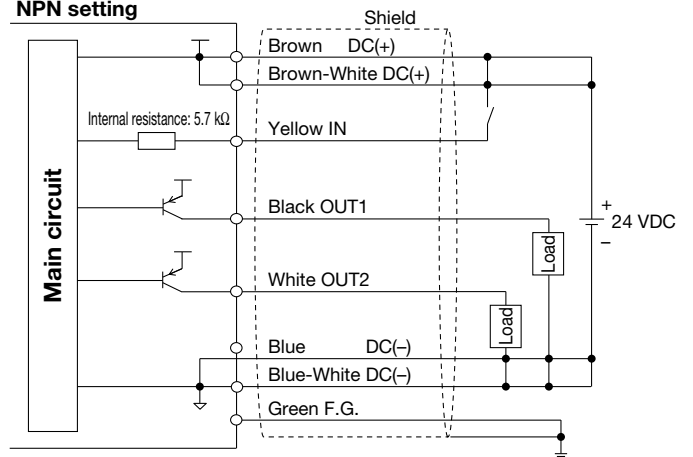

Dimensions

Ionizer / IZT44, IZT45

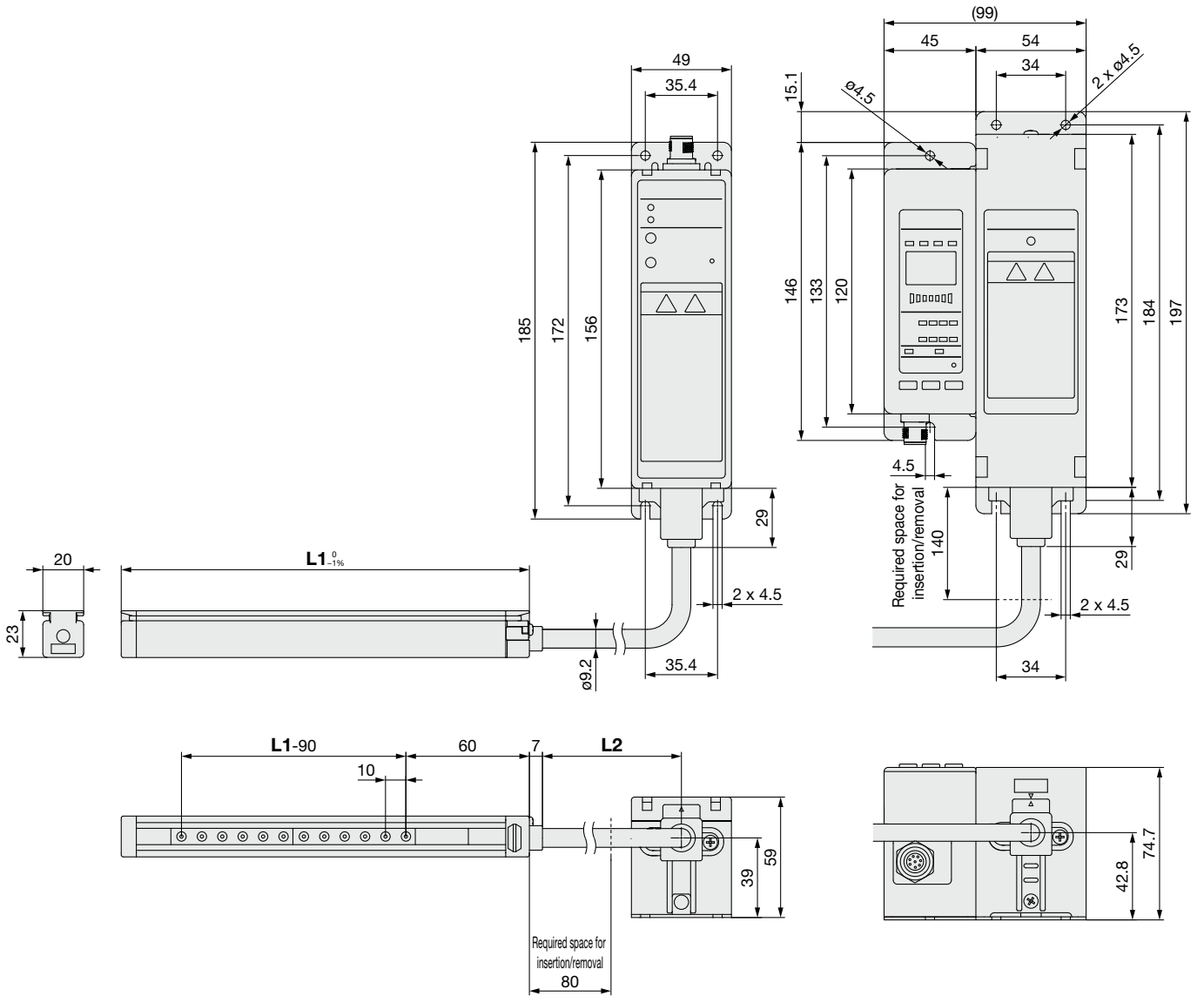
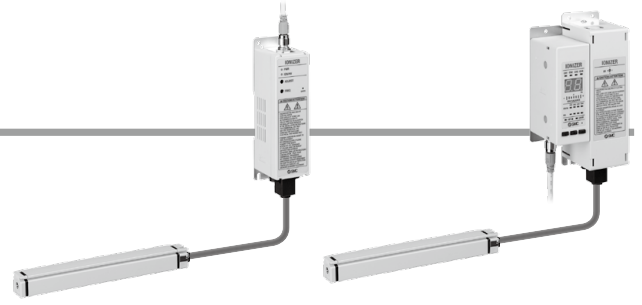

Bar Length L1

Model	L1 ⁰ _{-1%} [mm]
IZT□-20	200
IZT□-26	260
IZT□-32	320
IZT□-38	380
IZT□-44	440
IZT□-50	500
IZT□-56	560
IZT□-62	620
IZT□-68	680
IZT□-74	740
IZT□-92	920
IZT□-128	1280

High Voltage Cable Length L2

Model	L2 [mm]
IZT□-□-1	1
IZT□-□-2	2
IZT□-□-3	3

IZT44 Ion Generation Frequency

Switch no.	Frequency [Hz]
0	1
1	3
2	5
3	8
4	10
5	15
6	20
7	30
8	DC +
9	DC -

IZT45 Ion Generation Frequency

Frequency display	Frequency [Hz]
1	1
3	3
5	5
8	8
10	10
15	15
20	20
30	30
d P	DC+
d n	DC-

IZT44/45 Series

Dimensions

End bracket / IZT44-BE

Intermediate bracket / IZT44-BM

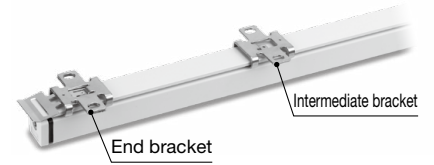
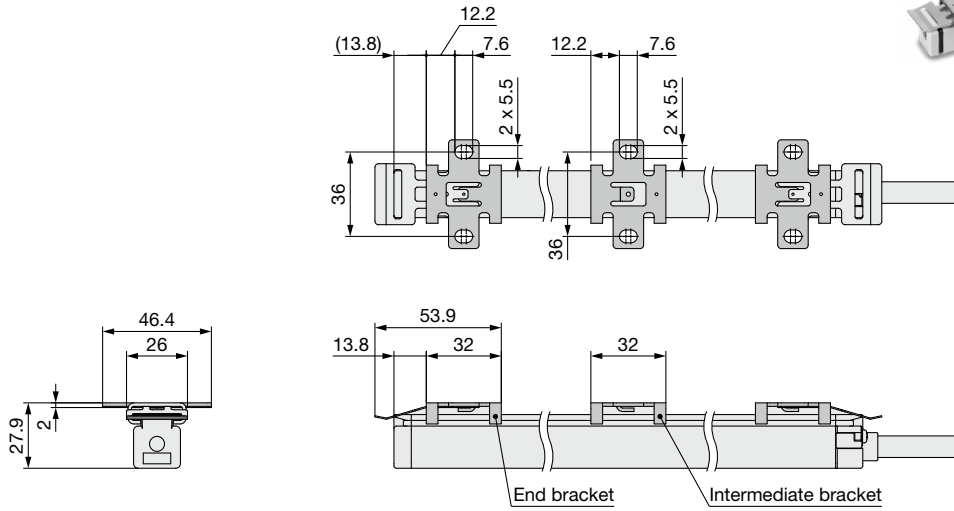

DIN rail mounting bracket for IZTC44 / IZT44-B1

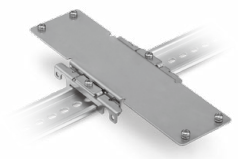
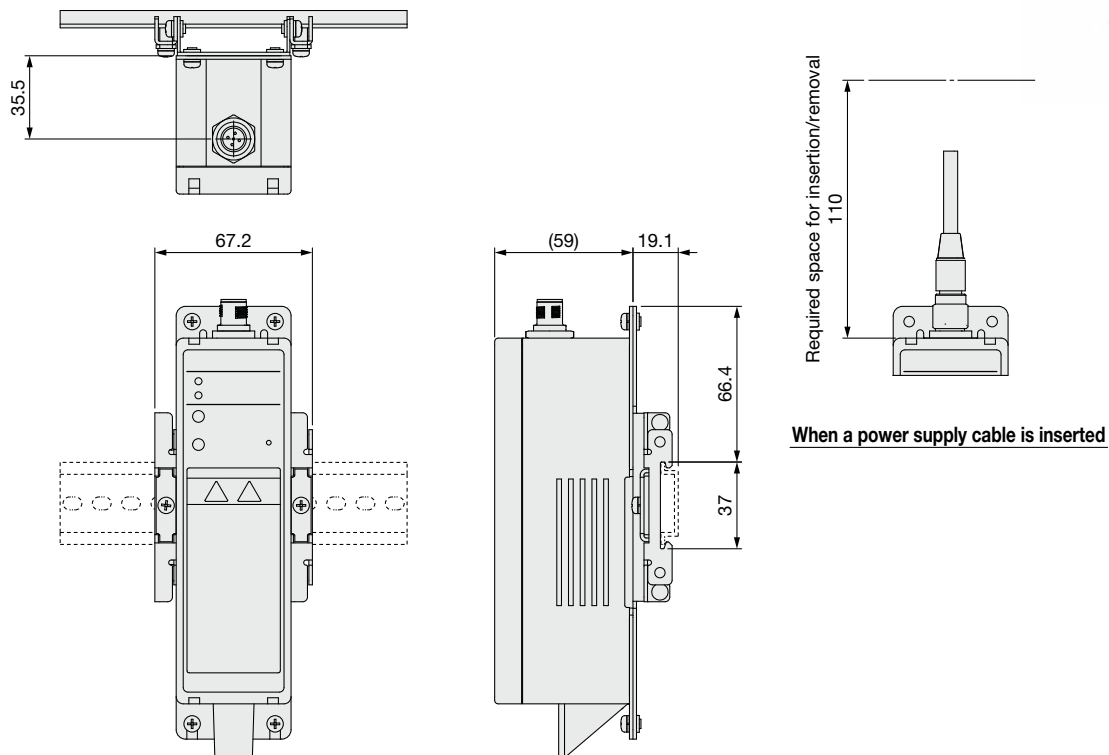

Dimensions

DIN rail mounting bracket for IZTC45 / IZT40-B1

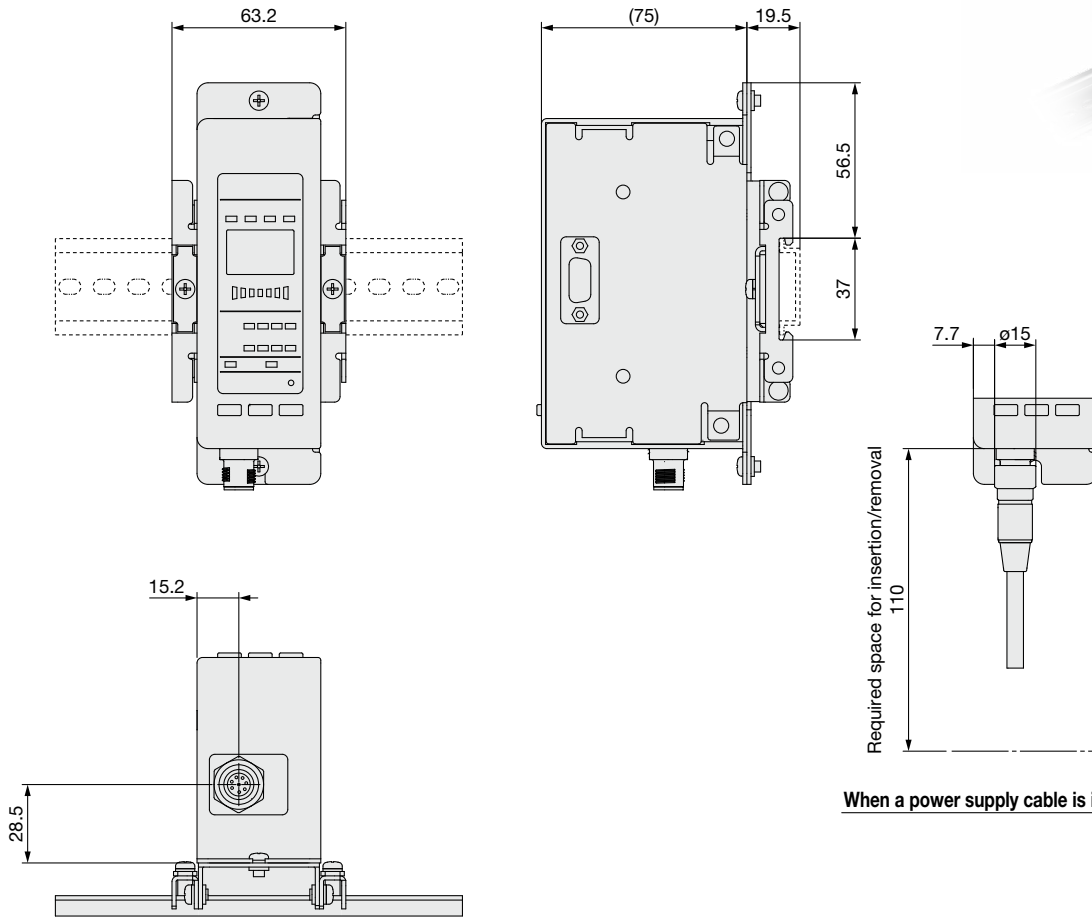

DIN rail mounting bracket for IZTP4□(-L) (IZT40-B2)

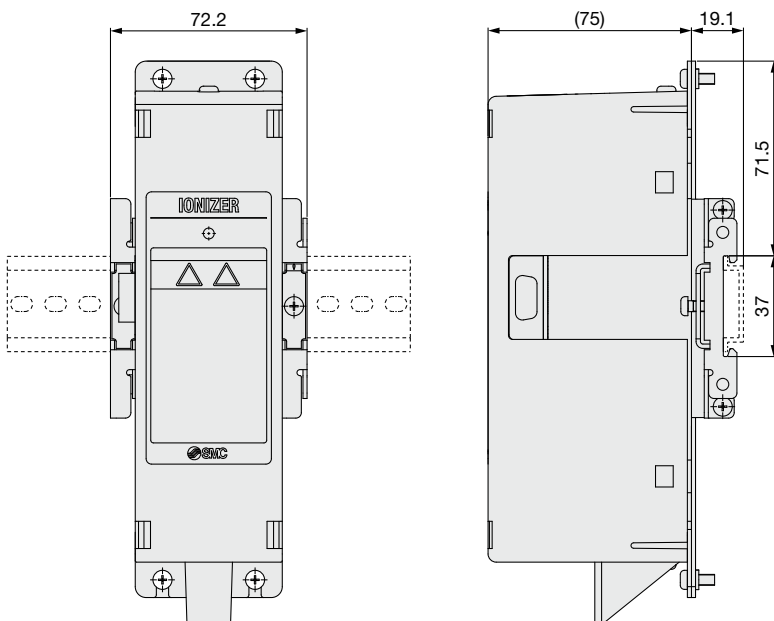

IZT44/45 Series

Dimensions

Power supply cable / IZT44-CP□

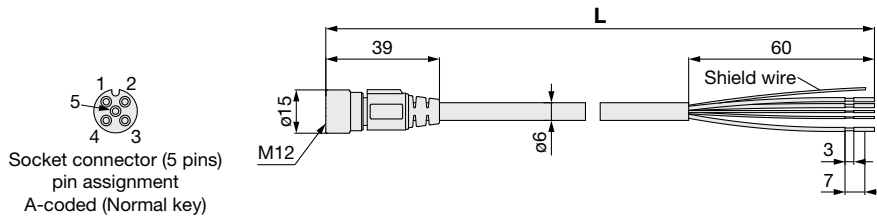

Power supply cable length L

Model	L [mm]
IZT44-CP3	3000
IZT44-CP5	5000
IZT44-CP10	10000

Power supply cable / IZT45-CP□

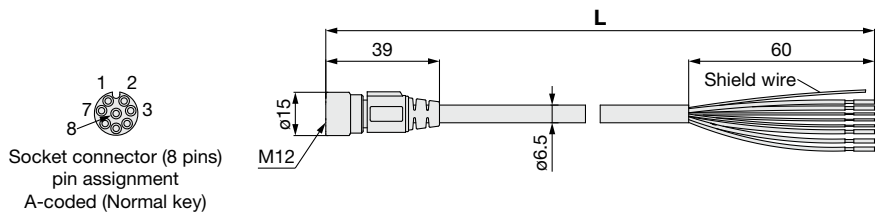

Power supply cable length L

Model	L [mm]
IZT45-CP3	3000
IZT45-CP5	5000
IZT45-CP10	10000

Branch cable / IZT44-A001

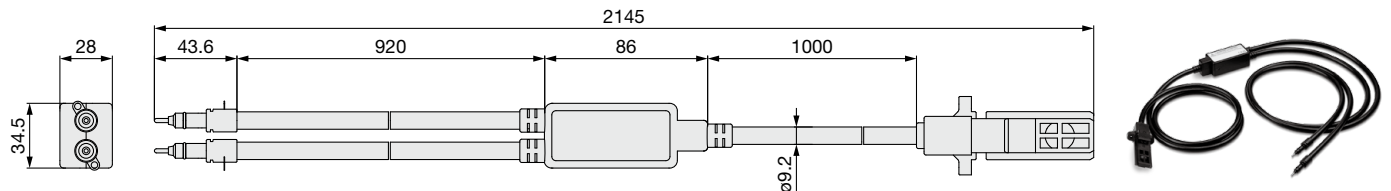

Separate cable / IZT40-CF□

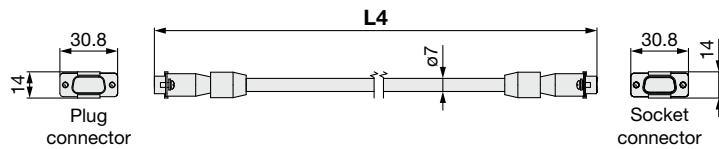

Cable Length L4

Model	L4 [mm]
IZT40-CF1	1000
IZT40-CF2	2000
IZT40-CF3	3000

When a separate cable is used

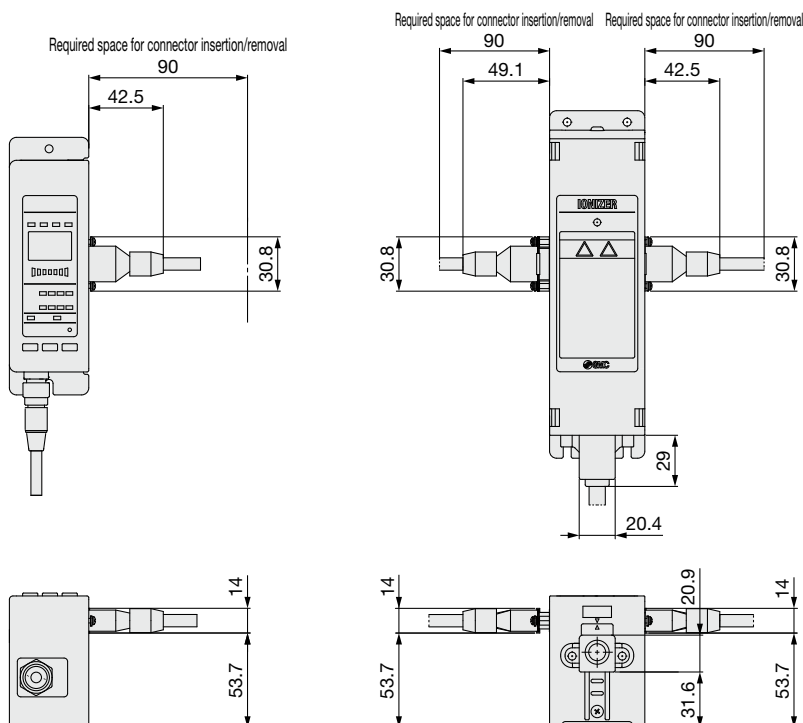

Dimensions

AC adapter: IZT44-CG₁, IZT45-CG₂

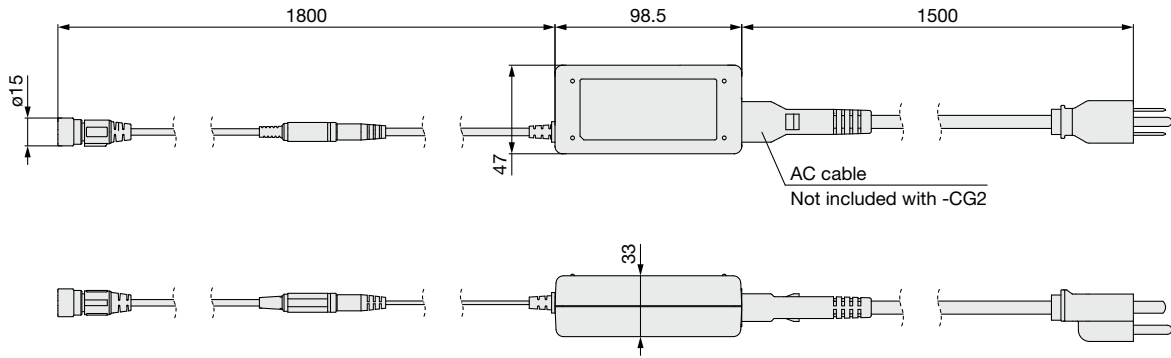

High voltage cable holder

Straight IZT40-E1

Cross-sectional view A-A

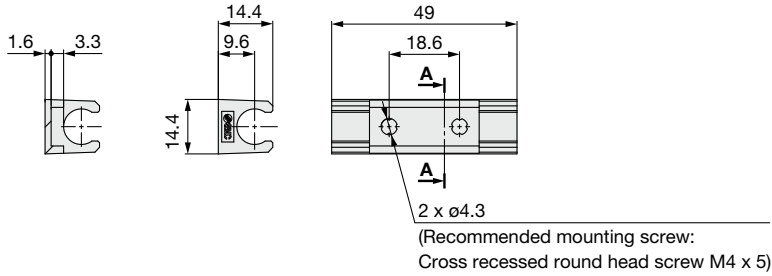

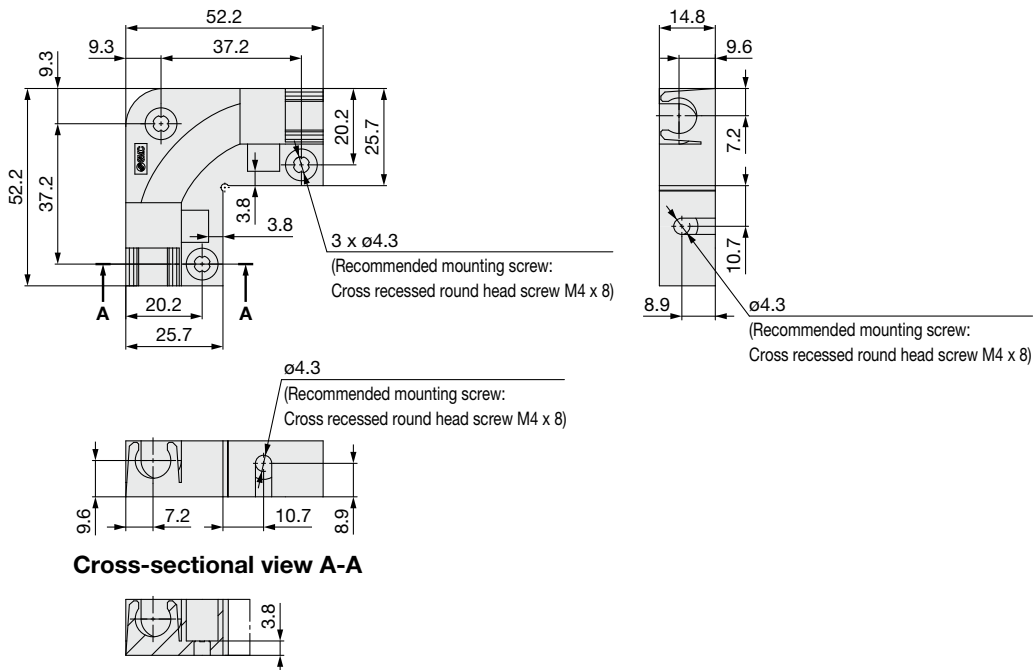

Elbow IZT40-E2





Compatibility with the Existing Products





Combinations available

Ion generation unit	Controller	Controller					High voltage power supply module				
		IZTC40	IZTC41	IZTC41-L	IZTC44	IZTC45	IZTP40	IZTP41	IZTP43	IZTP41-L	IZTP43-L
Slim bar 	IZTB44	○					○				
	IZTB44		○					○			
	IZTB44			○						○	
	IZTB44				○						○
	IZTB44					○					○
Bar (with air purge) 	IZTB40	○					○				
	IZTB40		○					○			
	IZTB40			○						○	
	IZTB40				○						○
	IZTB40					○					○
Nozzle 	IZTN43		○						○		
	IZTN43			○							○
	IZTN43					○					○



Combination example 1 When using the slim bar IZTB44 with IO-Link

Bar	Controller	High voltage power supply module
IZTB44 	IZTC41-L 	IZTP41-L 

Combination example 2 When using the bar IZTB40 (with air purge) with M12 power supply cable

Bar	Controller with High voltage power supply	Bar	Controller	High voltage power supply module
IZTB40 	IZTC44 	IZTB40 	IZTC45 	IZTP41-L 

Combination example 3 When using the nozzle IZTN43 with M12 power supply cable

Nozzle	Controller	High voltage power supply module
IZTN43 	IZTC45 	IZTP43-L 

Safety Instructions

These safety instructions are intended to prevent hazardous situations and/or equipment damage. These instructions indicate the level of potential hazard with the labels of “**Caution**,” “**Warning**” or “**Danger**.” They are all important notes for safety and must be followed in addition to International Standards (ISO/IEC)*1), and other safety regulations.

 **Danger :** **Danger** indicates a hazard with a high level of risk which, if not avoided, will result in death or serious injury.

 **Warning:** **Warning** indicates a hazard with a medium level of risk which, if not avoided, could result in death or serious injury.

 **Caution:** **Caution** indicates a hazard with a low level of risk which, if not avoided, could result in minor or moderate injury.

*1) ISO 4414: Pneumatic fluid power - General rules and safety requirements for systems and their components
ISO 4413: Hydraulic fluid power - General rules and safety requirements for systems and their components
IEC 60204-1: Safety of machinery - Electrical equipment of machines - Part 1: General requirements
ISO 10218-1: Robots and robotic devices - Safety requirements for industrial robots - Part 1: Robots etc.

Warning

1. The compatibility of the product is the responsibility of the person who designs the equipment or decides its specifications.

Since the product specified here is used under various operating conditions, its compatibility with specific equipment must be decided by the person who designs the equipment or decides its specifications based on necessary analysis and test results. The expected performance and safety assurance of the equipment will be the responsibility of the person who has determined its compatibility with the product. This person should also continuously review all specifications of the product referring to its latest catalog information, with a view to giving due consideration to any possibility of equipment failure when configuring the equipment.

2. Only personnel with appropriate training should operate machinery and equipment.

The product specified here may become unsafe if handled incorrectly. The assembly, operation and maintenance of machines or equipment including our products must be performed by an operator who is appropriately trained and experienced.

3. Do not service or attempt to remove product and machinery/equipment until safety is confirmed.

1. The inspection and maintenance of machinery/equipment should only be performed after measures to prevent falling or runaway of the driven objects have been confirmed.
2. When the product is to be removed, confirm that the safety measures as mentioned above are implemented and the power from any appropriate source is cut, and read and understand the specific product precautions of all relevant products carefully.
3. Before machinery/equipment is restarted, take measures to prevent unexpected operation and malfunction.

4. Our products cannot be used beyond their specifications. Our products are not developed, designed, and manufactured to be used under the following conditions or environments. Use under such conditions or environments is not covered.

1. Conditions and environments outside of the given specifications, or use outdoors or in a place exposed to direct sunlight.
2. Use for nuclear power, railways, aviation, space equipment, ships, vehicles, military application, equipment affecting human life, body, and property, fuel equipment, entertainment equipment, emergency shut-off circuits, press clutches, brake circuits, safety equipment, etc., and use for applications that do not conform to standard specifications such as catalogs and operation manuals.
3. Use for interlock circuits, except for use with double interlock such as installing a mechanical protection function in case of failure. Please periodically inspect the product to confirm that the product is operating properly.

Caution

We develop, design, and manufacture our products to be used for automatic control equipment, and provide them for peaceful use in manufacturing industries.

Use in non-manufacturing industries is not covered.

Products we manufacture and sell cannot be used for the purpose of transactions or certification specified in the Measurement Act.

The new Measurement Act prohibits use of any unit other than SI units in Japan.

Limited warranty and Disclaimer/ Compliance Requirements

The product used is subject to the following “Limited warranty and Disclaimer” and “Compliance Requirements”.

Read and accept them before using the product.

Limited warranty and Disclaimer

1. The warranty period of the product is 1 year in service or 1.5 years after the product is delivered, whichever is first.*2)
Also, the product may have specified durability, running distance or replacement parts. Please consult your nearest sales branch.
2. For any failure or damage reported within the warranty period which is clearly our responsibility, a replacement product or necessary parts will be provided. This limited warranty applies only to our product independently, and not to any other damage incurred due to the failure of the product.
3. Prior to using SMC products, please read and understand the warranty terms and disclaimers noted in the specified catalog for the particular products.

*2) **Vacuum pads are excluded from this 1 year warranty.**

A vacuum pad is a consumable part, so it is warranted for a year after it is delivered.

Also, even within the warranty period, the wear of a product due to the use of the vacuum pad or failure due to the deterioration of rubber material are not covered by the limited warranty.

Compliance Requirements

1. The use of SMC products with production equipment for the manufacture of weapons of mass destruction (WMD) or any other weapon is strictly prohibited.
2. The exports of SMC products or technology from one country to another are governed by the relevant security laws and regulations of the countries involved in the transaction. Prior to the shipment of a SMC product to another country, assure that all local rules governing that export are known and followed.

Safety Instructions

Be sure to read the “Handling Precautions for SMC Products” (M-E03-3) and “Operation Manual” before use.

SMC Corporation