

Plug-in Bottom Ported Manifold with Stainless Steel Plate

Bottom seal/stainless steel plate prevents the flooding of valves

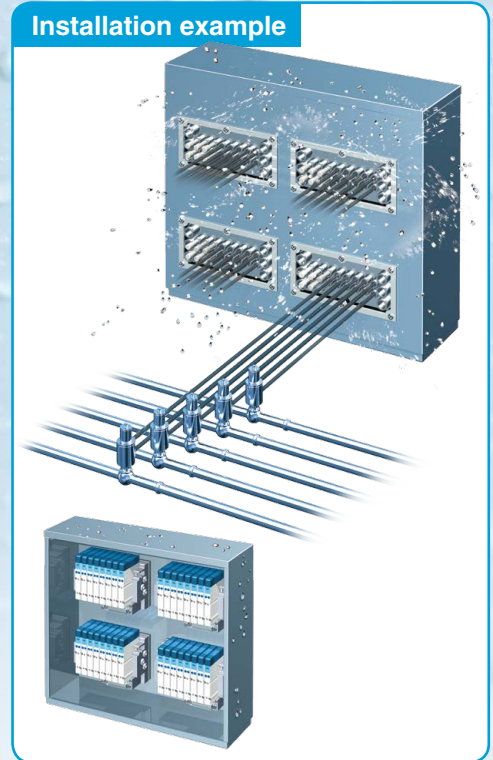

Trim plate (Option) p. 10

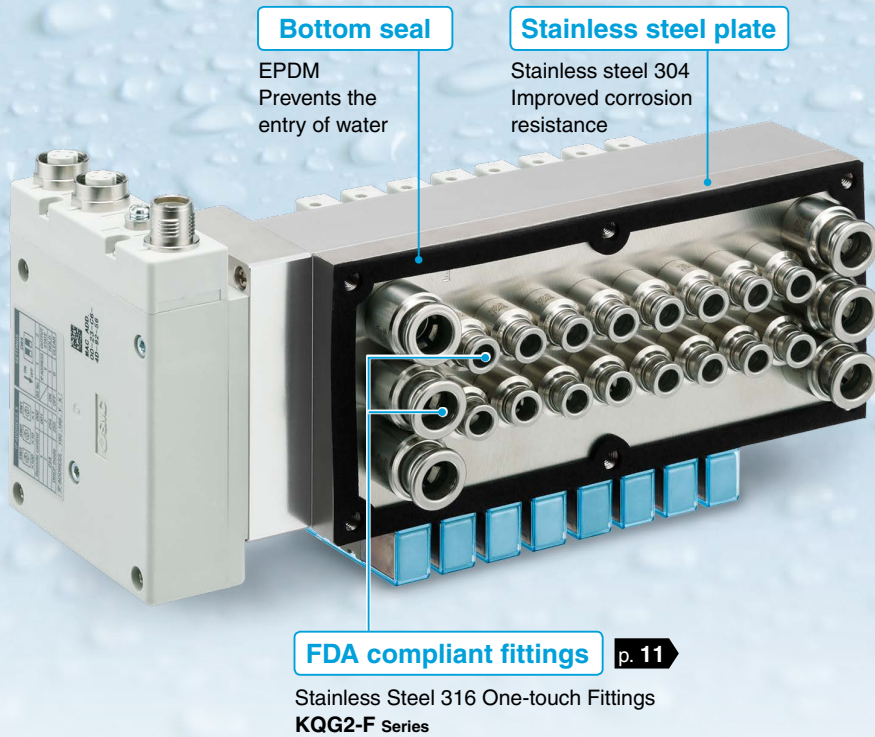
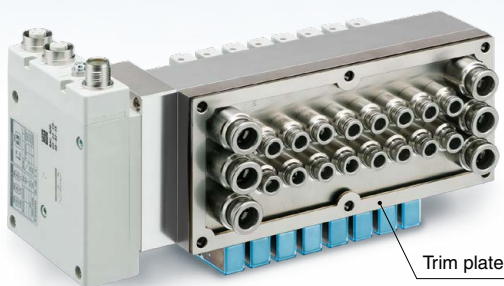

Wiring

D-sub connector/Flat ribbon cable/Terminal block box/Lead wire/
Serial unit (EX600, EX245, EX250, EX260)

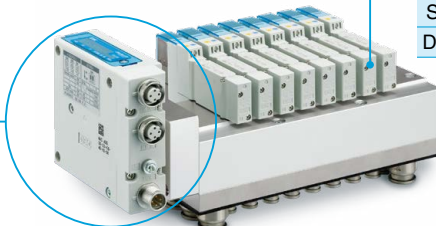
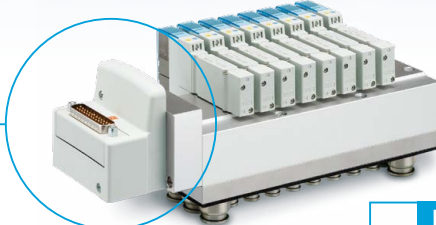

Manifold	
Single wiring	20, 24 stations
Double wiring	8, 12, 16 stations

JSY3000-S Series

Compatible with **EtherNet/IP** and **IO-Link** (EX260)

JSY3000-S Series Type 51

Plug-in Bottom Ported Manifold with Stainless Steel Plate

Manifold Specifications

Model	D-sub connector	Flat ribbon cable			Terminal block box	
	F type	P type	PG type (20 pins)	TC type (Spring type)	T type (Screw clamping type)	
Number of pins/outputs	25 pins	26 pins	20 pins	32 outputs	20 outputs	
Manifold type	Plug-in metal base, Bottom ported					
SUP/EXH port type	Common SUP/EXH					
Valve stations*1	Double wiring	8, 12 stations	8, 12 stations	8 stations	8, 12, 16 stations	8 stations
	Single wiring	8, 12, 16, 20, 24 stations	8, 12, 16, 20, 24 stations	8, 12, 16 stations	8, 12, 16, 20, 24 stations	8, 12, 16, 20 stations
Port size	4(A), 2(B) port	1/8" (R, G, NPT)				
	1(P), 3(EB), 5(EA) port	1/4" (R, G, NPT)				
Enclosure (Bottom ported installation surface only)*2	IP67					

*1 The wiring can only be all double wiring or all single wiring. The number of manifold stations is limited by the number of outputs of the SI units and connector assemblies connected. For the single wiring specification, only single valves can be mounted. Double, 3-position, or 4 position valves cannot be used with the single wiring specification.

*2 The enclosure IP rating is for when the product's bottom surface is mounted on a cabinet or panel. Equipped with valves, the electric wiring side is IP40.

Manifold Flow Rate Characteristics

Model	Port size		Valve flow rate characteristics*3			
	1, 5, 3 (P, EA, EB)	4, 2 (A, B)	1 → 4/2 (P → A/B)		4/2 → 5/3 (A/B → E)	
			C [dm ³ /(s·bar)]	b	C [dm ³ /(s·bar)]	b
JJ5SY3-S51	G1/4"	G1/8"	2.31	0.43	2.13	0.31

*3 The values are for an individually operated 2-position type manifold base with 8 stations.

* Calculation of effective area S and sonic conductance C: $S = 5.0 \times C$

Response Time/Valve Weight

Series	Seal type	Model	Type of actuation	Response time [ms] (At 0.5 MPa)*4		Weight [g]
				With light/surge voltage suppressor		
				Z type	U type	
JSY3000	Rubber seal	JSY3100	2-position single	27	18	54.0
		JSY3200	2-position double	13	12	63.0
		JSY3(3/4/5)00	3-position	27	24	67.0
		JSY3(A/B/C)00	4-position dual 3-port valve	23	23	63.0

*4 Based on the dynamic performance test, JIS B 8419-2010 (Coil temperature: 20°C, at rated voltage)

Manifold Weight

Model	Description	Number of stations				
		8	12	16	20	24
JJ5SY3-S51S0-□□-01	Manifold base	1814	2359	2904	3444	4018
JJ5SY3-S51S0-□□-C6	Manifold base (With fitting)	2317	2955	3593	4226	4893
JSY31M-191P-1A-□□	Trim plate	38.0	48.1	58.3	68.4	75.5

* The "□□" indicates the number of stations.

* To obtain the weight with valves attached, add the valve weights given above for the appropriate number of stations.

* Add the weight of option "P" (trim plate) separately.

* The weights of connector assemblies and SI units are not included. Add the weights on the next page. For I/O units, refer to the JSY series **Web Catalog** and add the weights separately.



Valve and manifold specifications not listed are the same as those of the standard product. More information can be viewed here.

Lead wire			Serial wiring					None
L type			S6□ (EX600)	SA□ (EX245)	S□ (EX250)	S□ (EX260)		S0
34 cores	17 cores	9 cores	32 outputs	32 outputs	32 outputs	32 outputs	16 outputs	32 outputs
Plug-in metal base, Bottom ported								
Common SUP/EXH								
8, 12, 16 stations	8 stations	—	8, 12, 16 stations	8, 12, 16 stations	8, 12, 16 stations	8, 12, 16 stations	8 stations	8, 12, 16 stations
8, 12, 16, 20, 24 stations	8, 12, 16 stations	8 stations	8, 12, 16, 20, 24 stations	8, 12, 16, 20, 24 stations	8, 12, 16, 20, 24 stations	8, 12, 16, 20, 24 stations	8, 12, 16 stations	8, 12, 16, 20, 24 stations
1/8" (R, G, NPT)								
1/4" (R, G, NPT)								
IP67								

Connector Assembly and SI Unit Weight

Unit: g

Description	Model	Part no.	Weight
D-sub connector	F	VVQC1000-F25-1	80
Flat ribbon cable	P	VVQC1000-P26-1	70
	PG	VVQC1000-P20-1	70
Terminal block box	TC	SY30M-130-1A	227
	T	VVQC1000-T0-1	439
Lead wire	L (34 cores, 0.6 m)	SY30M-14-4A-1-1	176
	L (34 cores, 1.5 m)	SY30M-14-4A-1-2	276
	L (34 cores, 3 m)	SY30M-14-4A-1-3	579
	L (17 cores, 0.6 m)	SY30M-14-4A-2-1	133
	L (17 cores, 1.5 m)	SY30M-14-4A-2-2	192
	L (17 cores, 3 m)	SY30M-14-4A-2-3	327
	L (9 cores, 0.6 m)	SY30M-14-4A-3-1	121
	L (9 cores, 1.5 m)	SY30M-14-4A-3-2	164
Serial unit	S6□	EX600-S□-□*1	300
	SA□	EX245-SPN1/2A	465
		EX245-SPN3A	540
		EX245-FPS1/2	1100
		EX245-FPS3	1200
	S□	EX250-S□-□*1	250
	S□	EX260-S□-□*1	200

*1 For details, refer to the **Web Catalog** of the plug-in JSY series.

Plug-in Bottom Ported Manifold with Stainless Steel Plate

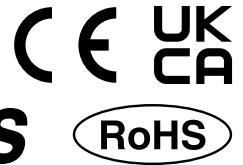

Type 51
Bottom Ported

JSY3000-S Series

D-sub connector/Flat ribbon cable/Terminal block box/Lead wire

Refer to page 5 for How to Order Manifolds for serial wiring.

How to Order Manifolds

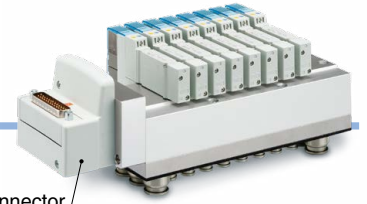

D-sub connector

- Connector entry direction adjustable D-sub connector
- Connector entry direction adjustable flat ribbon cable
- (Spring type) Terminal block box

Lead wire

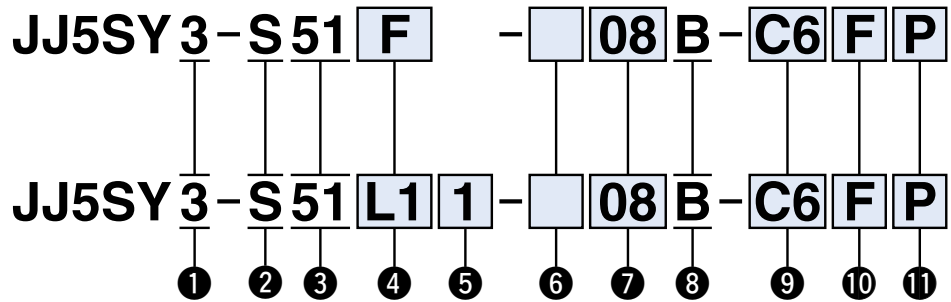

1 Series

3	JSY3000
---	---------

2 Manifold with stainless steel plate

3 Plug-in metal base, Bottom ported

4 Wiring/Connection

Symbol	Type
F	Connector entry direction adjustable D-sub connector (25 pins)
P	Connector entry direction adjustable flat ribbon cable (26 pins)
PG	Connector entry direction adjustable flat ribbon cable (20 pins)
TC	Spring type terminal block box (32 outputs)
T	Terminal block box (20 outputs)
L1	Lead wire (34 cores)
L2	Lead wire (17 cores)
L3	Lead wire (9 cores)

* Refer to the manifold specifications on pages 1 and 2 for details on wiring.

5 Lead wire length When lead wire "L1," "L2," or "L3" is selected

1	0.6 m
2	1.5 m
3	3 m

6 Wiring type

Symbol	Note
Nil	All double wiring*1
S	All single wiring*2, *3

- *1 2-position single, 2-position double, 3-position, and 4-position valves can be used on all manifold stations.
- *2 Only single valves can be used. Other valves cannot be used.
- *3 Only the single wiring specification can be selected if 20 or 24 stations is required. (Add an "S" to the part number when ordering.)

7 Valve stations

Symbol	Stations	Note
08	8 stations	All double wiring*4
12	12 stations	
16	16 stations	
20	20 stations	All single wiring
24	24 stations	

*4 Depending on the wiring (type) and connection methods, it may be changed to the single wiring specification.

8 1(P), 5(EA)/3(EB) port entry

B	Both sides
---	------------

9 4(A)/2(B) port size One-touch fitting*5 p. 11

Symbol	4(A)/2(B) port	1(P)/3(EB), 5(EA) port
C6	ø6	ø10
C8	ø8	
N7	ø1/4"	ø3/8"

Thread piping

Symbol	4(A)/2(B) port	1(P)/3(EB), 5(EA) port
01	1/8	1/4

*5 Fittings are shipped together with the product. In addition, the thread of the enclosed fitting is a G thread. For details, refer to page 11.

10 Thread type (Fill in only for thread piping.)

Nil	Rc
F	G
N	NPT

11 Option p. 10

Nil	None
P	Trim plate

How to Order Manifold Assembly

Example (JJ5SY3-S51F-08B-01)

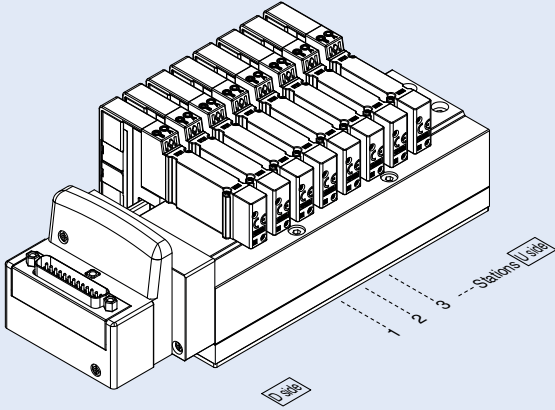

JJ5SY3-S51F-08B-01 ... 1 set (8-station manifold base part no.)
 * JSY3200-5U 4 sets (2-position double part no.)
 * JSY3A00-5U 4 sets (4-position dual 3-port (N.C./N.C.) part no.)
 → The asterisk denotes the symbol for the assembly.
 Prefix it to the part numbers of the valve, etc.

- For the valve arrangement, the valve closest to the D side is considered the 1st station.
- Under the manifold part number, state the valves to be mounted in order starting with the 1st station as shown in the figure. If the arrangement becomes too complicated, specify the details on a manifold specification sheet.

Refer to pages 3, 5, and 6 for How to Order Manifolds.

How to Order Valves

JSY 3 **1** 0 0 **5** **Z**

1
2
3
4
5
6
7
8

1 Series

3	JSY3000
----------	---------

2 Type of actuation

1	2-position single
2	2-position double
3	3-position closed center
4	3-position exhaust center
5	3-position pressure center
A	Dual 3-port (N.C./N.C.)
B	Dual 3-port (N.O./N.O.)
C	Dual 3-port (N.C./N.O.)

3 Base mounted

4 Pilot valve exhaust method

0	Pilot valve individual exhaust
----------	--------------------------------

5 Coil type

Nil	None
T	With power-saving circuit (Made to order) p. 12

6 Rated voltage

5	24 VDC
----------	--------

* For the type with a power-saving circuit, only "Z" or "NZ" can be selected for 7 Light/surge voltage suppressor and common specification.

7 Light/surge voltage suppressor and common specification

Symbol	With light	Surge voltage suppressor	Common specification
U	●	●	Non-polar
Z	●	●	Positive common
NZ	●	●	Negative common

* When the non-polar common specification type is selected, take measures to prevent surge voltage.

8 Manual override

Nil	Non-locking push type
D	Push-turn locking slotted type
E	Push-turn locking lever type

Plug-in Bottom Ported Manifold with Stainless Steel Plate

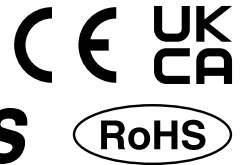

Type 51
Bottom Ported

JSY3000-S Series

Serial wiring

Refer to page 3 for How to Order Manifolds for the D-sub connector, flat ribbon cable, terminal block box, and lead wire.

How to Order Manifolds

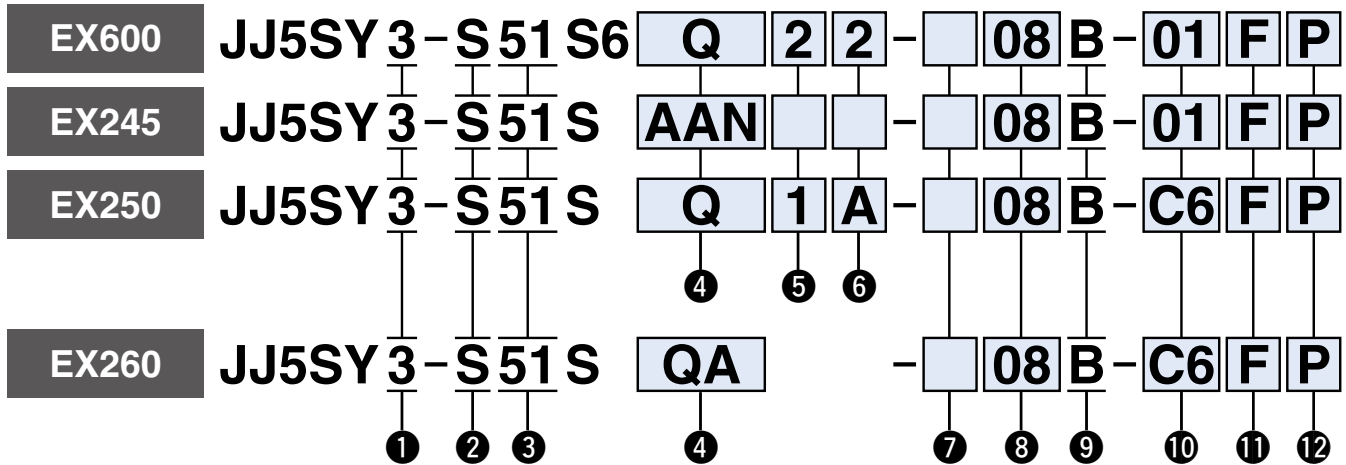

1 Series

3	JSY3000
---	---------

2 Manifold with stainless steel plate

3 Plug-in metal base, Bottom ported

For EX600

4 SI unit

0	Without SI unit
Q	DeviceNet® (Version A)
N	PROFIBUS DP (Version A)
V	CC-Link
EA	EtherNet/IP™ (2 ports)
F	PROFINET
FA	PROFINET (IO-Link unit)
WE	EtherNet/IP™ compatible wireless base*1
WF	PROFINET compatible wireless base*1
WS	Wireless remote*1

- *1 The wireless system is suitable for use only in a country where it is in accordance with the Radio Act and regulations of that country.
- * I/O unit cannot be mounted without SI unit.
- * Valve plate which connects manifold and SI unit is included, but it is not mounted to a valve without SI unit. For mounting, refer to the EX600 series in the **Web Catalog**.

5 SI unit output polarity, End plate type (Part no.)

SI unit output polarity	M12 power supply connector B-coded (EX600-ED2)	7/8 inch power supply connector (EX600-ED3)	M12 power supply connector IN/OUT, A-coded	
			Pin arrangement 1 (EX600-ED4)	Pin arrangement 2 (EX600-ED5)
Without SI unit	Nil			
SI unit Positive common	2	3	6	8
SI unit Negative common	4	5	7	9

- * Ensure a match with the common specification of the valve to be used.
- * When not selecting an SI unit, the symbol will be "nil."

6 I/O unit stations

Nil	None
1	1 station
:	:
9	9 stations

- * When not selecting an SI unit, the symbol will be "nil."
- * SI unit is not included in I/O unit stations.
- * When I/O unit is selected, it is shipped separately, and assembled by users. Refer to the attached operation manual for mounting.

For EX245

4 SI unit

Symbol (Output polarity)	Protocol	Communication connector	Communication connector specifications
Negative common (PNP)			
0		Without SI unit	
AAN	PROFINET	Push/Pull (SCRJ): 2 pcs.	Push/Pull (24 V): 2 pcs.
ABN		Push/Pull (RJ45): 2 pcs.	Push/Pull (24 V): 2 pcs.
ACN		M12: 2 pcs.	7/8 inch: 2 pcs.

- * The valve output polarity for the SI unit is negative common (PNP).

5 With or without I/O modules

Nil	Without I/O module
Y	With I/O module

- * When not selecting an SI unit, the symbol will be "nil."

6 Number of I/O modules

Nil	Without I/O module
1	1 station
:	:
8	8 stations

- * When not selecting an SI unit, the symbol will be "nil."

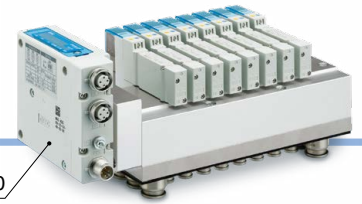

EX260

For EX250

4 SI unit

0	Without SI unit		
Q	DeviceNet® (Negative common)		
N	PROFIBUS DP (Negative common)		
TA	AS-Interface (Negative common)	2 power supply systems	8 in/8 out
TB			4 in/4 out
TC		1 power supply system	8 in/8 out
TD			4 in/4 out
Y	CANopen (Negative common)		
ZE	EtherNet/IP™ (Negative common)		

- * Ensure a match with the common specification of the valve to be used.
- * Input block cannot be mounted without SI unit.
- * The supply current from the SI unit of AS-Interface applicable 1 power supply system specification to the input block and valve is limited.

5 Input block stations

Nil	None
1	1 station
⋮	⋮
8	8 stations

- * When not selecting an SI unit, the symbol will be "nil." The maximum number of stations is limited for the AS-Interface applicable SI unit.

6 Input block type

	PNP sensor input	NPN sensor input
Without input block	Nil	
M12, 2 inputs	A	D
M12, 4 inputs	B	E
M8, 4 inputs	C	F

- * When not selecting an SI unit, the symbol will be "nil."

For EX260

4 SI unit (Output polarity, Protocol, Number of outputs, Communication connector)

Symbol (Output polarity)		Protocol	Number of outputs	Communication connector	Symbol (Output polarity)		Protocol	Number of outputs	Communication connector
Positive common (NPN)	Negative common (PNP)				Positive common (NPN)	Negative common (PNP)			
0 *1		Without SI unit			DA	DAN	EtherCAT	32	M12
QA	QAN	DeviceNet®	32	M12	DB	DBN		16	
QB	QBN		PROFIBUS DP		16	D-sub*3	FA	FAN	32
NA	NAN	32		M12	FB		FBN	16	
NB	NBN	16			M12		EA	EAN	32
NC	NCN	32		M12			EB	EBN	16
ND	NDN	16	M12		—*2	GAN	Ethernet	32	M12
VA	VAN	32		M12	—*2	GBN		POWERLINK	
VB	VBN	16	M12		—*2	KAN	IO-Link	32*4	M12

- *1 Without SI unit, the output polarity is decided by the SI unit used. Ensure a match with the common specification of the valves to be used.
- *2 Positive common (NPN) type is not available.
- *3 IP40 for the D-sub applicable communication connector specification.
- *4 Only the 32 outputs type is available.
- * DIN rail cannot be mounted without SI unit.

7 Wiring type

Symbol	Note
Nil	All double wiring*1
S	All single wiring*2, *3

- *1 2-position single, 2-position double, 3-position, and 4-position valves can be used on all manifold stations.
- *2 Only single valves can be used. Other valves cannot be used.
- *3 Only the single wiring specification can be selected if 20 or 24 stations is required. (Add an "S" to the part number when ordering.)

8 Valve stations

Symbol	Stations	Note
08	8 stations	All double wiring*1
12	12 stations	
16	16 stations	
20	20 stations	All single wiring
24	24 stations	

- *1 Depending on the wiring (type) and connection methods, it may be changed to the single wiring specification.

9 1(P), 5(EA)/3(EB) port entry

B	Both sides
----------	------------

10 4(A)/2(B) port size

Symbol	4(A)/2(B) port	1(P)/3(EB), 5(EA) port
C6	ø6	ø10
C8	ø8	
N7	ø1/4"	ø3/8"

Thread piping

Symbol	4(A)/2(B) port	1(P)/3(EB), 5(EA) port
01	1/8	1/4

- *1 Fittings are shipped together with the product. In addition, the thread of the enclosed fitting is a G thread. For details, refer to page 11.

Trademark

EtherNet/IP® is a registered trademark of ODVA, Inc.

11 Thread type (Fill in only for thread piping.)

Nil	Rc
F	G
N	NPT

12 Option p. 10

Nil	None
P	Trim plate

JSY3000-S Series

Dimensions

JJ5SY3-S51□□- Stations B-01□

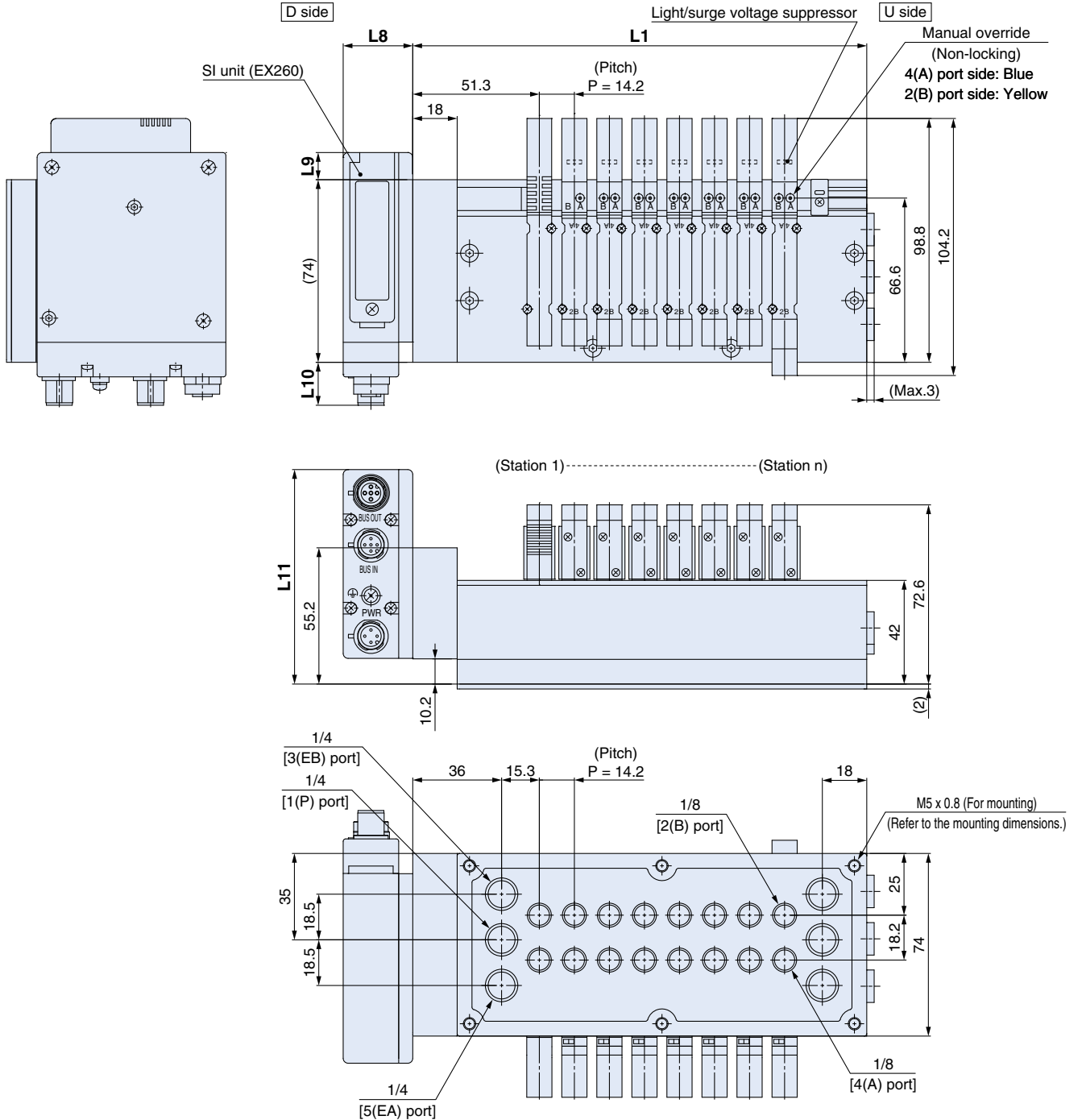

* These figures show the JJ5SY3-51SFAN-08B-01.

L: Dimensions (Manifold model: JJ5SY1-S51S0-□□-01)

	D-sub	Flat ribbon	Terminal block		Lead wire	Serial			
	F	P	TC	T	L	EX600	EX245	EX250	EX260
L8	36.5	36.5	67.5	88.8	36.5	81.0	112.6	102.0	28.2
L9	1.0	1.0	28.4	35.9	-1.4	23.4	23.4	4.0	11.0
L10	-8.2	-8.2	0.2	15.1	11.8	8.6	34.8	10.2	17.4
L11	70.2	70.2	81.2	87.9	66.8	66.8	102.2	70.2	86.9

□□: Number of stations

Dimensions

JJ5SY3-S51□□-Stations B-01□

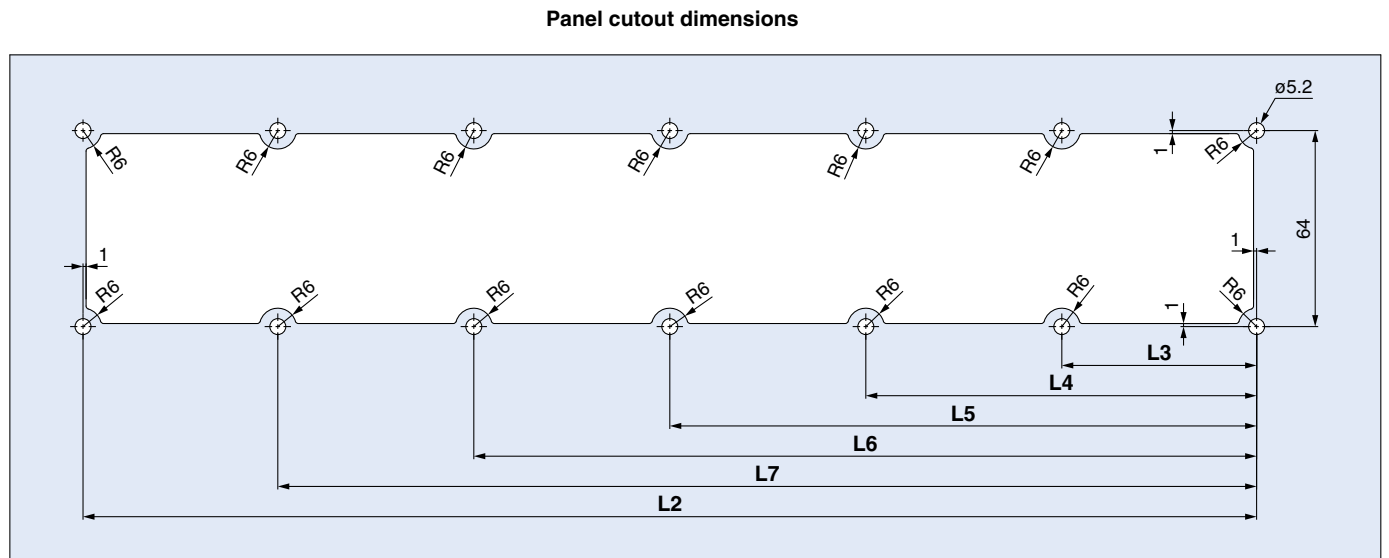
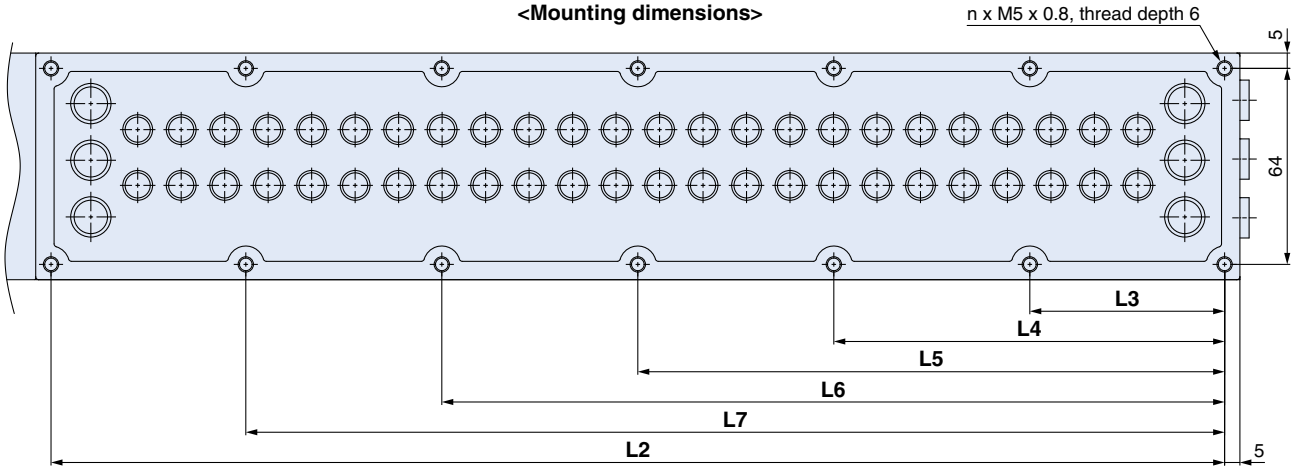

L: Dimensions (Manifold model: JJ5SY1-S51S0-□□-01)

Stations	8	12	16	20	24
L1	184.0	240.8	297.6	354.4	411.2
L2	156.0	212.8	269.6	326.4	383.2
L3	78.0	71.0	67.4	65.7	63.6
L4	—	141.8	134.8	130.7	127.6
L5	—	—	202.2	195.7	191.6
L6	—	—	—	260.7	255.6
L7	—	—	—	—	319.6

□□: Number of stations

JSY3000-S Series Manifold Exploded View

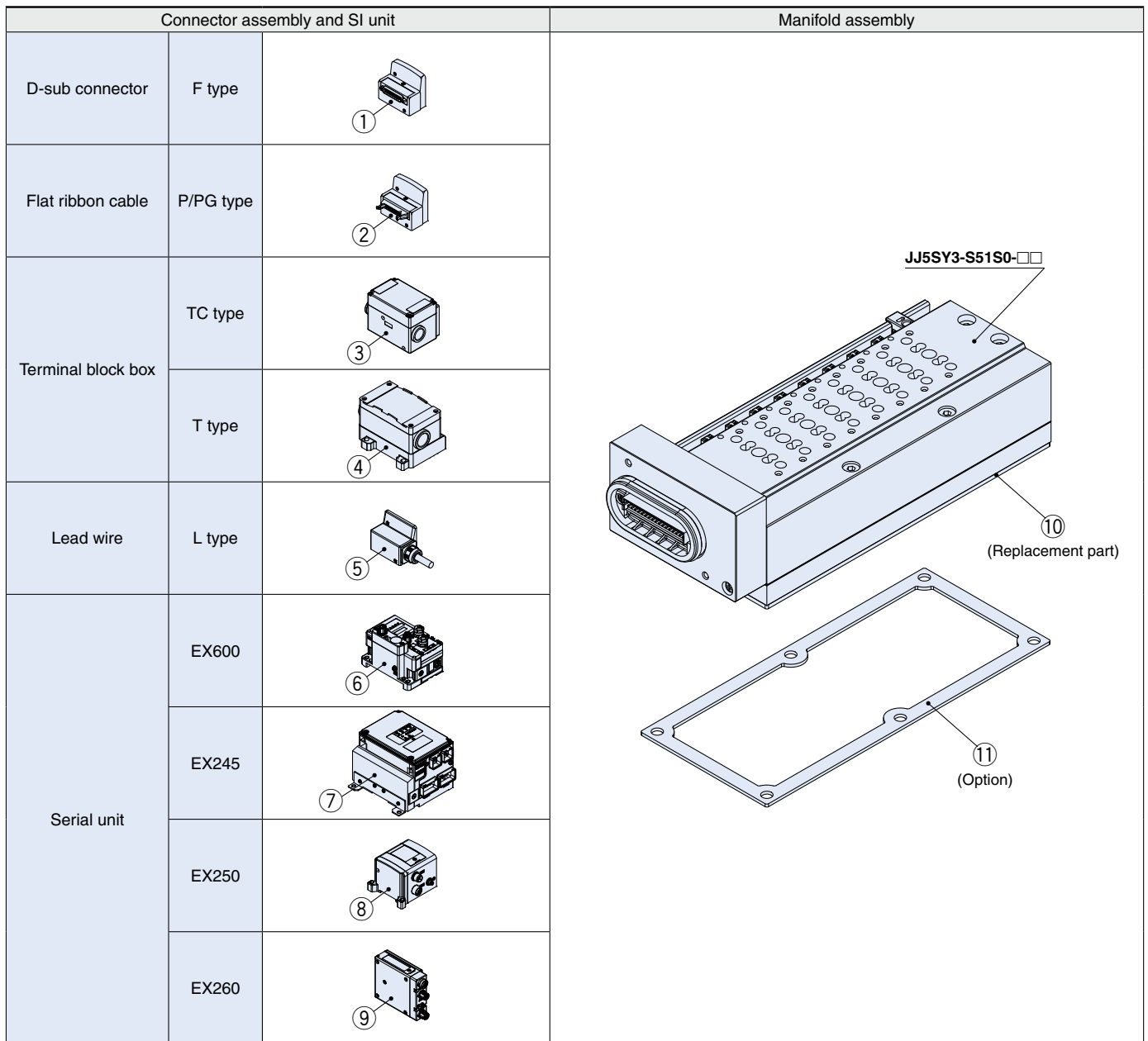

Assembly and Part Nos.

No.	Description	Part no.	Note
1	D-sub connector	VVQC1000-F25-1	25 pins
2	Flat ribbon cable	VVQC1000-P26-1	26 pins
		VVQC1000-P20-1	20 pins
3	Terminal block box	SY30M-130-1A	32 outputs, Spring type
4		VVQC1000-T0-1	20 outputs, Screw clamping type
5	Lead wire	SY30M-14-4A-1-1	34 cores, 0.6 m
		SY30M-14-4A-1-2	34 cores, 1.5 m
		SY30M-14-4A-1-3	34 cores, 3 m
		SY30M-14-4A-2-1	17 cores, 0.6 m
		SY30M-14-4A-2-2	17 cores, 1.5 m
		SY30M-14-4A-2-3	17 cores, 3 m
		SY30M-14-4A-3-1	9 cores, 0.6 m
		SY30M-14-4A-3-2	9 cores, 1.5 m
		SY30M-14-4A-3-3	9 cores, 3 m

No.	Description	Part no.	Note
6		EX600-S□-□*1	
		EX245-SPN1/2A	
7	Serial unit	EX245-SPN3A	
		EX245-FPS1/2	
		EX245-FPS3	
8		EX250-S□-□*1	
9		EX260-S□-□*1	
10	Bottom seal	JSY31M-90P-1A-□	□: Number of stations
11	Trim plate	JSY31M-191P-1A-□	□: Number of stations

*1 For details, refer to the **Web Catalog** of the plug-in JSY series.

JSY3000-S Series Options

Option/Replacement Part Nos.

Trim Plate

- A decorative panel to make the appearance look clean when used with a roughly cut cabinet
- If the wall of the cabinet is thin and the gasket seals are not uniform, it can be attached to stabilize the gasket seating force.

JSY31M-191P-1A-8

Thread piping

Symbol	Stations
8	8
12	12
16	16
20	20
24	24

Material:
Stainless steel 304

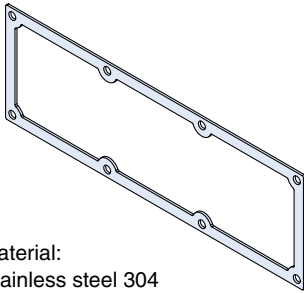

Mounting example

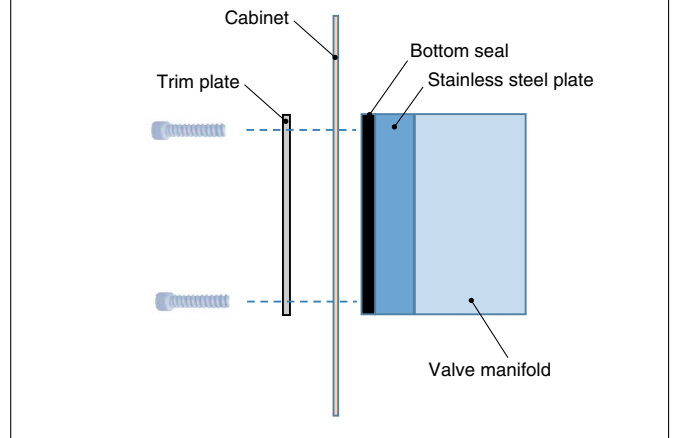

Bottom Seal

JSY31M-90P-1A-8

Thread piping

Symbol	Stations
8	8
12	12
16	16
20	20
24	24

Material: EPDM

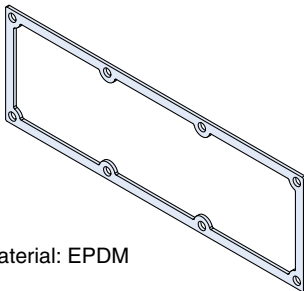

Blanking Plate

[With 2 mounting screws]

Used when valve additions are expected or for maintenance

JSY 3 1M-26P-2A

Series

3	JSY3000
---	---------

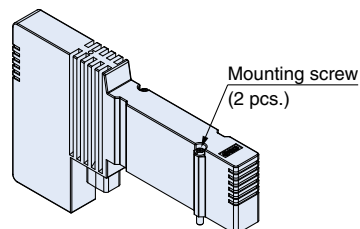

JSY31M-26P-2A

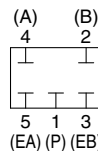

Circuit diagram

Caution

Tightening torque for mounting screws
M2: 0.16 N·m (JSY3000)

JSY3000-S Series

Option/Replacement Part Nos.

Individual SUP Spacer

[With a connector gasket, a base gasket, and two mounting screws]
When the same manifold is to be used for different pressures, an individual SUP spacer assembly can be used to act as a supply port for different pressures.

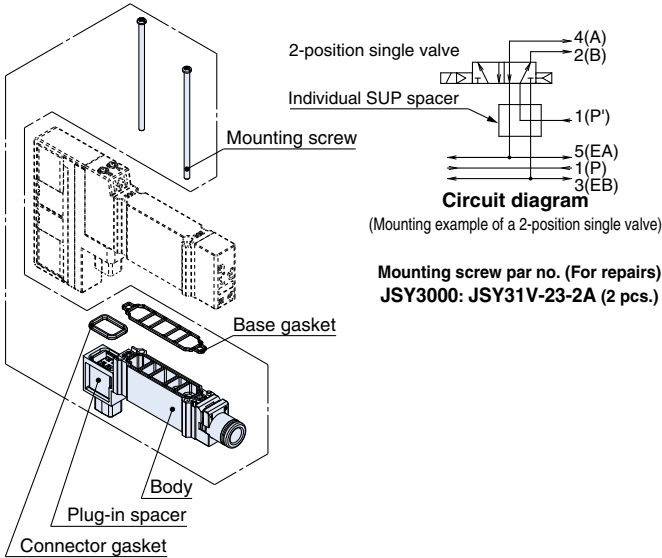

Individual EXH spacer

[With a connector gasket, a base gasket, and two mounting screws]
When valve exhaust affects other stations due to the circuit configuration, this spacer can be used for individual valve exhaust.

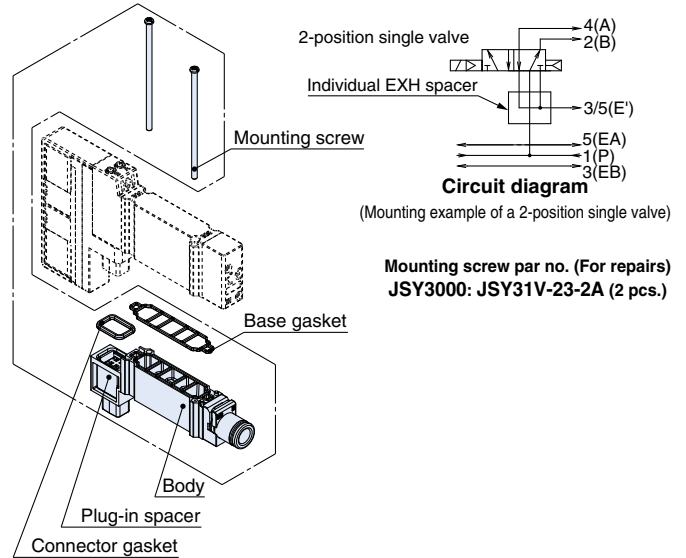

JSY 3 1M-38 P-1A-C6

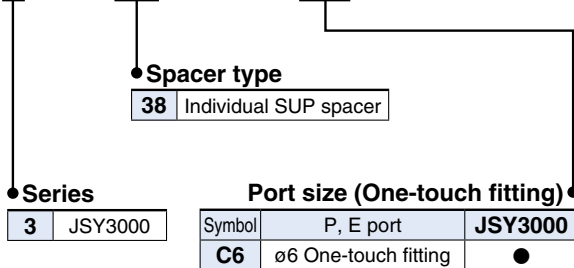

Caution

Tightening torque for mounting screw
M2: 0.16 N·m (JSY3000)

JSY 3 1M-39 P-1A-C6

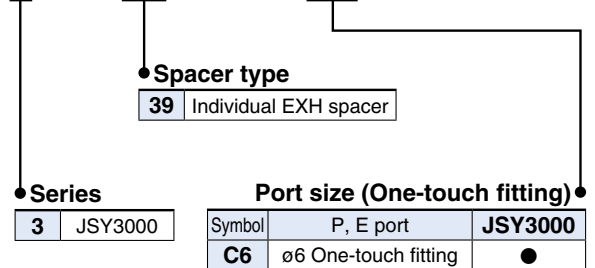

Caution

Tightening torque for mounting screw
M2: 0.16 N·m (JSY3000)

FDA Compliant Fittings/Stainless Steel 316 One-touch Fittings

Symbol	Fitting part no.	
	4(A), 2(B) port	1(P), 3(EB), 5(EA) port
C6	KQG2S06-G01-F	KQG2S10-G02-F
C8	KQG2S08-G01-F	
N7	KQG2S07-G01-F-X73	KQG2S11-G02-F-X73

Tighten fittings with sealant using the proper tightening torques in the table below.

Connection thread size	Proper tightening torque [N·m]
G01(G1/8)	3 to 5
G02(G1/4)	8 to 12

Insufficient tightening may cause seal failure or loosen the threads.

For reuse

(1) Normally, fittings with a sealant can be reused up to 6 to 10 times.

(2) The seal ring cannot be replaced.

For other precautions, refer to the specific product precautions in the **Web Catalog** of the KQG2-F series.



JSY3000-S Series

Made to Order

Please contact SMC for detailed dimensions, specifications, and delivery times.



1 Coil type: With power-saving circuit (Continuous duty type)

Power consumption: 0.1 W

How to Order Valves

Refer to page 4 for How to Order.

JSY3 00 T - 5

• Coil type

With power-saving circuit (Continuous duty type)

Caution

Be sure to select the power-saving circuit type if the valve is to be continuously energized for long periods of time. Be careful of the energizing time when the power-saving circuit is selected.

* Refer to the "With power-saving circuit" section in the "Specific Product Precautions" of the plug-in type JSY series **Web Catalog** for details.

**Plug-in Bottom Ported Manifold
with Stainless Steel Plate**

 **Safety Instructions** Be sure to read the "Handling Precautions for SMC Products" (M-E03-3) and "Operation Manual" before use.

SMC Corporation

