

Valve Mounted Cylinder/Non-rotating Rod Type: Double Acting

Series CV3K

Non-lube Type: $\phi 40$, $\phi 50$, $\phi 63$

Construction

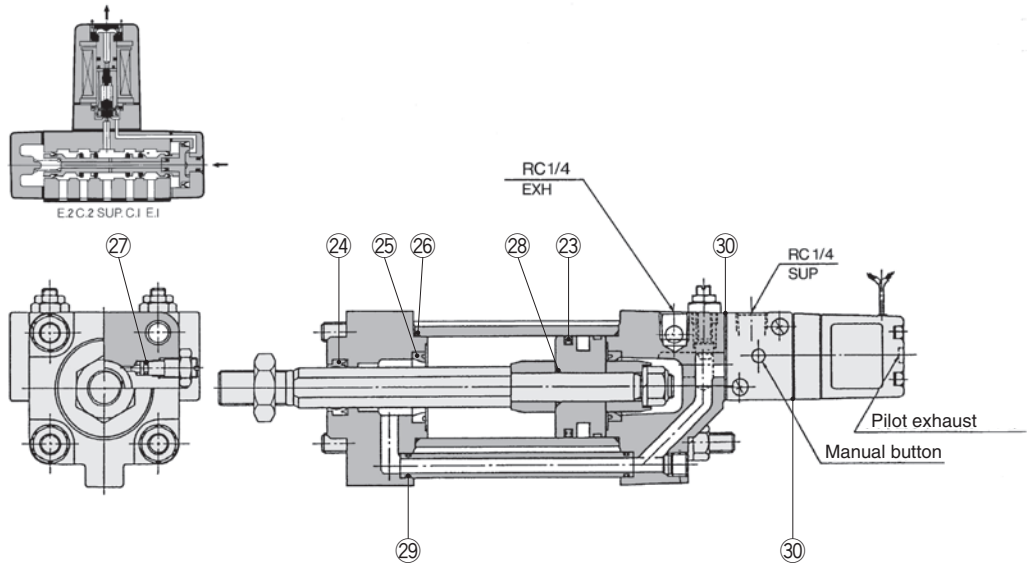

* The numbers are the same as the "Construction" of the Best Pneumatics No.3 Series CV3K.

Seal Kit List

No.	Description	Material	Note
23	Piston seal	NBR	25 and 28 are non-replaceable parts, so they are not included in the seal kit.
24	Rod seal		
25	Cushion seal		
26	Cylinder tube gasket		
27	Cushion valve seal		
28	Piston gasket		
29	Pipe gasket		
30	Head cover gasket		

Replacement Parts: Seal Kit

Bore size (mm)	Kit no.	Contents
40	CV3K40-PS	Set of left nos. 23, 24, 26, 27, 29, 30
50	CV3K50-PS	
63	CV3K63-PS	

* Seal kit includes 23, 24, 26, 27, 29, 30. Order the seal kit, based on each bore size.

* Seal kit includes a grease pack ($\phi 40$, $\phi 50$: 10 g, $\phi 63$ or more: 20 g). Order with the following part number when only the grease pack is needed.

Grease pack part no.: GR-S-010 (10 g), GR-S-020 (20 g)

Disassembly/Replacement

1. Please consult with SMC when the rod seal is to be replaced.

When the rod seal is to be replaced, make sure that the seal's width across flats matches that of the non-rotating guide.

A rod seal may allow air leakage depending on the position where it is installed. Therefore, please consult with SMC when a rod seal is to be replaced.

2. Do not replace the non-rotating guide.

Since the non-rotating guide is press fitted, the entire cover assembly needs to be replaced instead of a single part.