

# Series CHAW

ø40, ø50, ø63, ø80  
ø100, ø125, ø160

## Construction

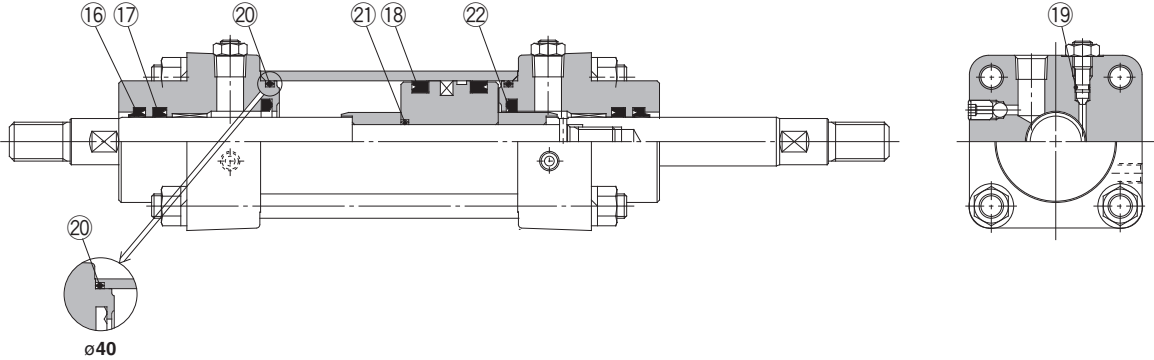

\* The numbers are the same as the "Construction" of the Best Pneumatics No.8 Series CHAW.

### Seal Kit List

No.	Description	Material	Note
16	Wiper ring	NBR	<b>21 is a non-replaceable part, so it is not included in the seal kit.</b>
17	Rod seal	NBR	
18	Piston seal	NBR	
19	Needle valve seal	NBR	
20	Cylinder tube gasket	NBR	
21	Piston gasket	NBR	
22	Cushion seal	—	

### Replacement Parts: Seal Kit

Bore size (mm)	Seal kit no.	Content
40	CHAW40-PS	Set of left nos. 16, 17, 18, 19, 20, 22
50	CHAW50-PS	
63	CHAW63-PS	
80	CHAW80-PS	
100	CHAW100-PS	
125	CHAW125-PS	
160	CHAW160-PS	

\* Seal kit consists of items of 16 through 20 and 22 and can be ordered by using the seal kit number for each bore size.

### Tie-rod Nut Tightening Torque

Bore size (mm)	Tightening torque(N·m)
40	10.8 ± 1.1
50	24.5 ± 2.4
63	24.5 ± 2.4
80	38.2 ± 3.8
100	38.2 ± 3.8
125	68.6 ± 6.8
160	107.8 ± 10.7

\* Gradually tighten the tie-rod nuts equally from opposing corners so that the tightening torques become the same as those listed above.