

Actuators

Replacement Procedure

CJP2	Pin Cylinder	P.278
CM2	Air Cylinder	P.280
CVM	Valve Mounted Cylinder	P.280
CG1	Air Cylinder	P.281
CG3	Air Cylinder Short Type	P.281
CG5-S	Stainless Steel Cylinder	P.281
MB	Air Cylinder	P.284
MB1	Square Tube Type Air Cylinder	P.284
CA2	Air Cylinder	P.284
CS1	Air Cylinder	P.287
CS2	Air Cylinder	P.287
CUJ	Mini Free Mount Cylinder	P.289
CQS	Compact Cylinder	P.290
CQ2	Compact Cylinder	P.290
RQ	Compact Cylinder with Air Cushion	P.290
CXT	Platform Cylinder	P.290
CVQ	Compact Cylinder With Solenoid Valve	P.290
HYQ	Hygienic Design Cylinder	P.297
HYC	Hygienic Design Cylinder	P.297
HYG	Hygienic Design Cylinder	P.301
MY1B	Mechanically Jointed Rodless Cylinder/Basic Type	P.304
MY1M	Mechanically Jointed Rodless Cylinder/Slide Bearing Guide Type	P.306
MY1C	Mechanically Jointed Rodless Cylinder/Cam Follower Guide Type	P.306
MY1□W	Mechanically Jointed Rodless Cylinder with Protective Cover	P.306
MY1H	Mechanically Jointed Rodless Cylinder/Linear Guide Type	P.310
MY2C	Mechanically Jointed Rodless Cylinder/Cam Follower Guide Type	P.311
MY2H/HT	Mechanically Jointed Rodless Cylinder/Linear Guide Type	P.311
MY3A	Mechanically Jointed Rodless Cylinders/Basic short type	P.312
MY3B	Mechanically Jointed Rodless Cylinders/Basic standard type	P.312
MY3M	Mechanically Jointed Rodless Cylinders/Slide bearing guide type	P.312
CY3B	Magnetically Coupled Rodless Cylinder/Basic Type	P.315
CY3R	Magnetically Coupled Rodless Cylinder/Direct Mount Type	P.316
REAR	Sine Rodless Cylinder	P.316
REBR	Sine Rodless Cylinder	P.316
CY1S	Magnetically Coupled Rodless Cylinder Slider Type/Slide Bearing	P.317
CY1L	Magnetically Coupled Rodless Cylinder Slider Type/Ball Bushing Bearing	P.318
MXS	Air Slide Table	P.319
MXQ	Air Slide Table	P.319
MXQR	Air Slide Table/Reversible Type	P.319
MXF	Low Profile Slide Table	P.324
MXW	Air Slide Table	P.325
MXP	Air Slide Table	P.326
MXY	Air Slide Table/Long Stroke Type	P.329
MGP	Compact Guide Cylinder	P.333

MGPW	Compact Guide Cylinder/Wide Type	P.333
MGQ	Compact Guide Cylinder	P.333
MGF	Guide Table	P.337
CXSJ/CXS/CXSW	Dual Rod Cylinder	P.339
CLG1	Fine Lock Cylinder	P.340
CL1	Lock-up Cylinder	P.343
CNG	Cylinder with Lock	P.348
MNB	Cylinder with Lock	P.351
CNA2	Cylinder with Lock	P.351
CNS	Cylinder with Lock	P.356
CLS	Cylinder with Lock	P.358
REAS	Sine Rodless Cylinder	P.361
REC	Sine Cylinder	P.362
RHC	High Power Cylinder	P.364
RZQ	3 Position Cylinder	P.367
MK	Rotary Clamp Cylinder/Standard	P.371
MK2T	Rotary Clamp Cylinder/Double Guide Type	P.371
CKQG/CKQP	Pin Clamp Cylinder	P.374
RSQ	Stopper Cylinder	P.385
RSG	Stopper Cylinder	P.385
RSH	Heavy Duty Stopper Cylinder	P.387
RS2H	Heavy Duty Stopper Cylinder	P.387
MIW/MIS	Escapements	P.390
CH□KD	JIS Standard Compact Hydraulic Cylinder	P.392
CH□KG	JIS Standard Compact Hydraulic Cylinder	P.393
CHN	Small Bore Hydraulic Cylinder	P.394
CHSD/CHSG	ISO Standard Hydraulic Cylinder	P.395
CH2□	JIS Standard Hydraulic Cylinder	P.396

Actuators

Modular F.R.L.
Pressure Control Equipment

Air Preparation
Equipment

Industrial Filters

Replacement
Procedure

Actuators

Modular F.R.L.
Pressure Control Equipment

Industrial Filters

Series CJP2 Replacement Procedure of Seal 1

Caution

Ask SMC for replacing a seal if a tube inside diameter is 4 mm.

Tubes with a 4 mm I.D cannot be disassembled. If they need to be disassembled in order to replace the packing or for other purposes, please contact an SMC representative for the repair.

1. Disassembly of the Cylinder

1-1. Cleaning

Prior to disassembly, wipe off any dirt from the outside of the actuator.

This will prevent the intrusion of dust and foreign materials during disassembly.

Take particular care on the surface of the piston rod.

1-2. Removal of retaining ring

Remove the retaining ring with proper pliers.

1-3. Removal of head cover

Remove the head cover from the body by pushing the piston rod to the head side.

1-4. Disassembly

Pull out the piston rod.

Take care not to scratch or mark the internal face of the body.

2. Removal of the Seal

2-1. Rod seal

Insert a watchmakers screw driver etc. from front the body and prise the seal out.

Take care not to scratch or score the seal groove in the body.

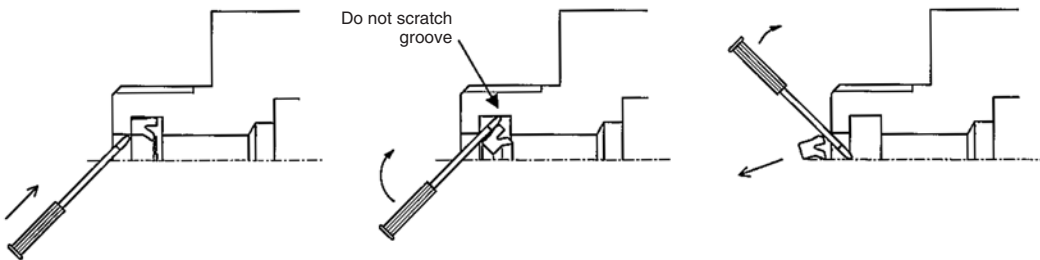

2-2. Piston seal

Push the tube gasket partially to make it come off and pull it out manually.

2-3. Gasket (See right)

Push the gasket partially to make it come off and pull it out manually.

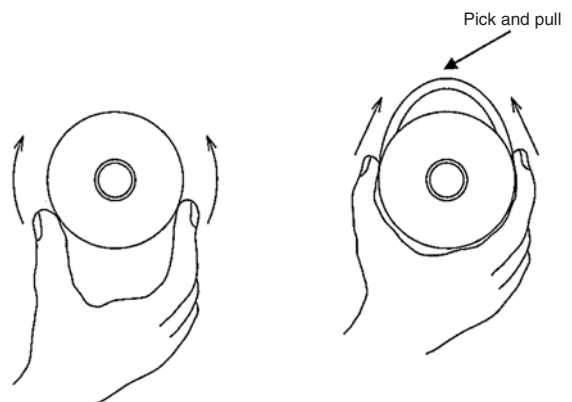

Series CJP2 Replacement Procedure of Seal 2

3. Application of Grease

3-1. Rod seal and Piston seal

Apply the grease evenly all around the new seal.

3-2. Gasket

Spread a thin film of grease over the tube gasket.

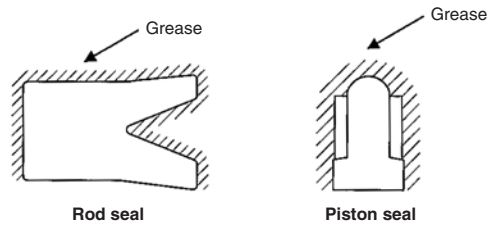

4. Mounting of Seal

4-1. Rod seal

Mount the rod seal with attention to direction.

Then, apply the grease on the rod seal and body bushing.

4-2. Piston seal

When mounting the seal, ensure there are no twists in the seal.

Also add the grease inside the groove.

4-3. Gasket

Pay attention not to make the gasket come off.

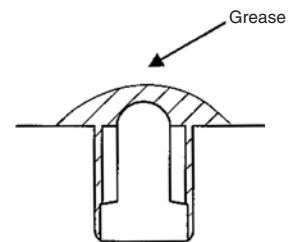
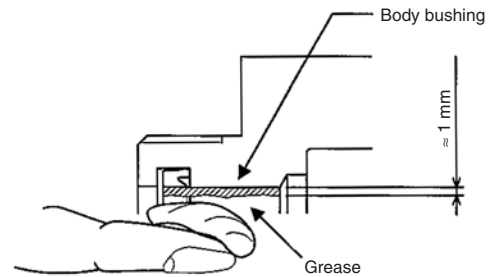

5. Application of Grease

5-1. Each component of the cylinder

Spread grease entirely over the parts shown.

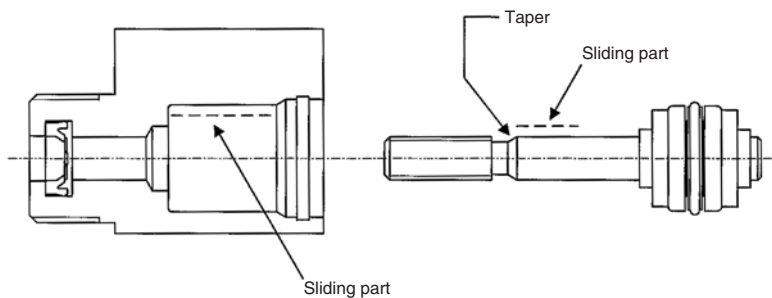

6. Reassembly of the Cylinder

6-1. Insertion of piston rod assembly

Please insert piston rod assembly in the body.

6-2. Insertion of head cover assembly

Please insert head cover assembly in the body.

6-3. Mounting of the retaining ring

Mount the retaining ring with proper pliers.

6-4. Check the assembly condition.

Confirm that there is no air leakage from the seal and that the cylinder can operate smoothly at a minimum operating pressure.

Actuators

Modular F.R.L.
Pressure Control Equipment

Air Preparation
Equipment

Industrial Filters

Replacement
Procedure

Actuators

Modular F.R.L.
Pressure Control Equipment

Industrial Filters

Caution

The cylinder of CM2/CVM series can not disassemble because the cover and the tube are connected by rolling caulking method.

1. How to Replace the Rod Seal

Replacement of the rod seal can be done even at the state of cylinder installed. As for replacement work, proceed as follows.

1-1. Demounting

When removing retaining ring by using a C-shaped retaining ring fitting tool for hole (snap ring pliers) and pulling out the piston rod at the state of rod cover port stopped up by finger, seal retainer and rod seal can be demounted.

1-2. Greasing

Use lithium soap base grease equivalent to JIS class 2.

Fulling lubricate by grease on inner-and-outer peripheries of new rod seals for replacement. Moreover, fill grease into groove and slot portions.

1-3. Mounting

Mounting the rod seal with paying attention as to direction. Slowly push the rod seal with slight rotation when letting the thread part of piston rod tip and width across flat part pass through and surely install to the rod cover housing.

Then, mount in the order of seal retainer and retaining ring.

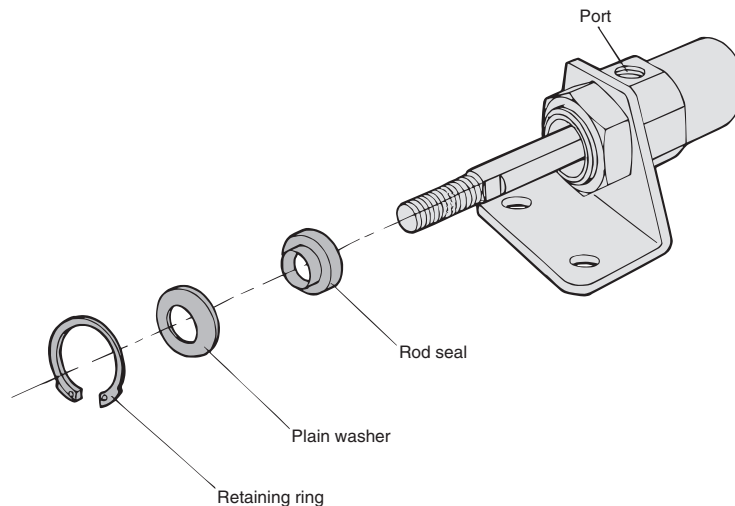

1. How to Replace the Seals

1-1. It is possible to replace the rod seal, piston seal, cylinder tube gasket for $\phi 20$ to $\phi 40$.

Series CBG1

For $\phi 20$ to $\phi 40$, it is possible to replace rod seal, piston seal, cylinder tube gasket and lock piston seal.

1-2. Contact SMC sales if it is necessary to replace seal for $\phi 50$ to $\phi 100$.

Series CBG1

For $\phi 50$ to $\phi 100$, it is possible to replace lock piston seal. For other seals, contact SMC.

1-3. Contact SMC sales if it is necessary to replace parts other than those mentioned above.

Warning

Only people who have sufficient knowledge and experience are allowed to replace seals.

The person who disassembles and reassembles the cylinder is responsible for the safety of the product.

Caution

When replacing seals, take care not to hurt your hand or finger on the corners of parts.

2. Disassembly/Reassembly

Caution

Disassemble and assemble the cylinder in a clean area. Perform on a clean cloth.

For disassembling, hold the flats of the tube cover gently in a vice and hold the flats of the rod cover with a spanner or monkey wrench to loosen and remove the rod cover. When reassembling, tighten 0 to 2 degrees more than the original position before disassembling.

Bore size of $\phi 50$ or more cannot be disassembled because they are tightened to a high torque.

Contact your SMC Sales representative if you need to disassemble these products.

For single-acting type, please be noted that the cover might pop up due to the internal spring.

Series CG5-S

The cover and cylinder tube are tighten with Loctite 542 as seal in order to prevent from leakage. Remove old loctite completely and put new loctite when reassemble cylinder.

3. Removal of the Seal

3-1. Rod seal

Insert a watchmakers screw driver from the front of the cover to pull out the seal as shown in Fig. 1.

Caution

Take care not to damage the seal groove of the cover at this time.

Series CG5-S

Whole rod cover assembly need to be changed when rod scraper of water resistant type is worn.

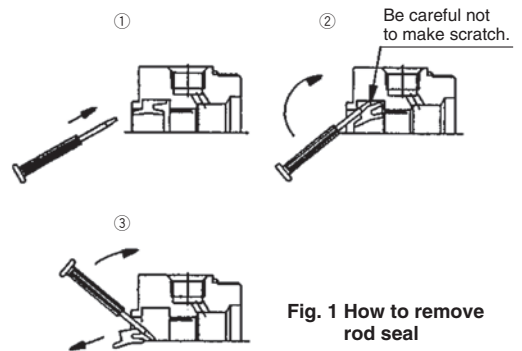

Fig. 1 How to remove rod seal

Series CG5-S

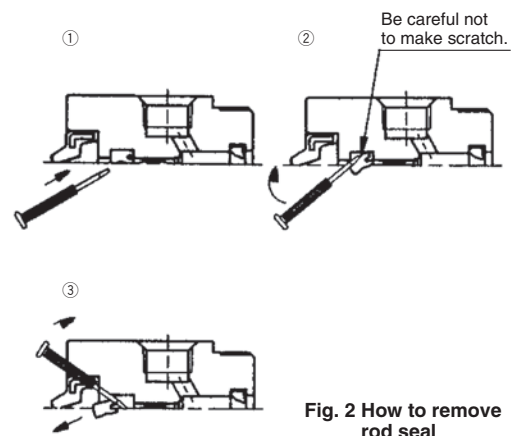

Fig. 2 How to remove rod seal

3-2. Piston seal

Wipe off grease around piston seal first to make removal easier.

Hold piston seal with one hand and push it into groove so that piston seal can be lifted off and pulled out without using a watchmakers screw driver. (Fig. 3)

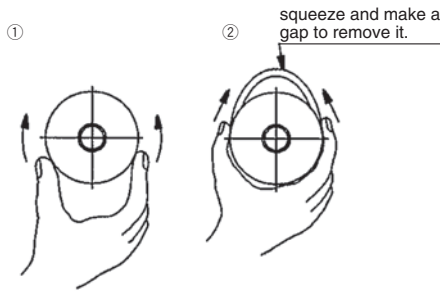

Fig. 3 How to remove piston seal

3-3. Tube gasket

Remove the tube gasket with the watchmakers screw driver or the like.

3-4. Valve seal, valve retaining gasket (Air cushion style only)

After disassembling by referring to Figure 4, pull out them by using a watchmakers screw driver.

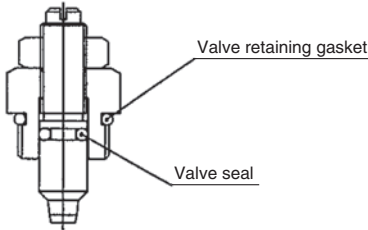

Fig. 4 Positions of valve seal and valve retaining gasket

3-5. Lock piston seal (End lock section)

Series CBG1

- a. Insert the manual bolt through the rubber cap of the end lock unit (This is not necessary for -*L lock style).
- b. Unscrew two hexagon socket head cap screws and pull out the end lock unit.
- c. For $\phi 20$ to $\phi 63$, remove the lock piston seal.
- d. For $\phi 80$ and $\phi 100$, remove the seal retainer and lock piston seal.

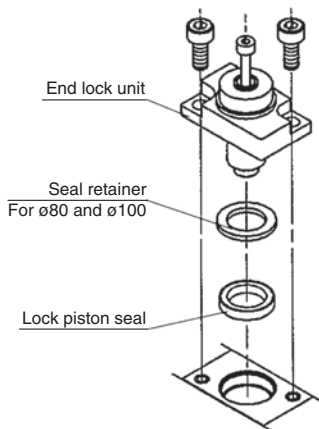

Fig. 5 How to remove lock piston seal

4. Application of Grease

⚠ Caution

Use lithium soap base grease equivalent to JIS class 2.

4-1. Rod seal, lock piston seal

Lightly apply grease to the circumference of a new seal to make mounting easier and have better contact with the cover. Fill in the groove with grease since this is necessary for operation.

4-2. Piston seal

Lightly and evenly apply grease to the inner and outer circumferences for easier mounting on the piston.

4-3. Tube gasket

Lightly apply grease. This prevents its drop when assembling the cylinder.

4-4. Valve seal and valve retaining gasket (Air cushion style only)

Lightly apply grease. This prevents their drop when assembling the valve.

4-5. Cylinder component parts

Apply grease to each component parts of the cylinder in Figure 6. Appendix table shows the grease amount required for a cylinder with stroke 100. For your reference, amount taken with a forefinger is about 3 (g).

$$L \approx 100 \text{ mm, or stroke} \times \frac{1}{2}$$

Series CG1

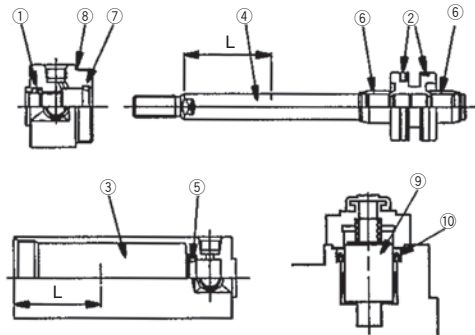
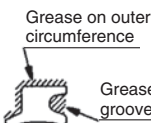
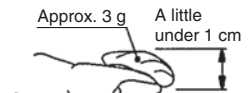

Fig. 6 Grease application points

Series CBG1/ End lock section



① Rod seal



Grease amount

Grease application amount (g)

Stroke	Bore size				Application points
	ø20	ø25	ø32	ø40	
100 st	2	3	3	3 to 4	①②③④⑤ ⑥⑦⑧⑨⑩
Extra 50 st	0.5	0.5	0.5	1	③④

* Rubber bumper style does not have ⑤, ⑥, and ⑦.
* ⑨ and ⑩ are the end lock parts of Series CBG1.

Series CG3

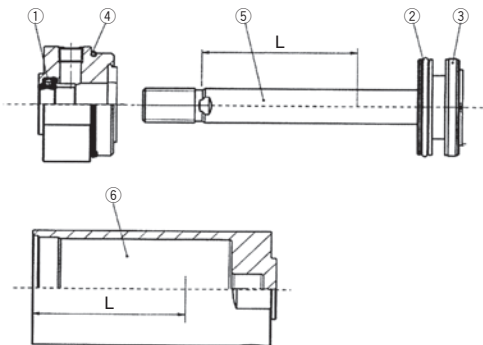

Fig. 7 Grease application points

Grease application amount (g)

Stroke	Bore size				Position for grease
	ø20	ø25	ø32	ø40	
At 100 st	2	3	3	3 to 4	①②③ ④⑤⑥
50 st increased	0.5	0.5	0.5	1	⑤⑥

5. Mounting of Seal

5-1. Rod seal

Be careful with the direction of seal while mounting. Apply grease to the seal and the inner circumference of the bush as Figure 8. For small bore sizes, use a watchmakers screw driver to apply grease.

5-2. Piston seal

After mounting the seal, rub grease into the seal groove and the outer circumference of the seal as Figure 9.

5-3. Tube gasket

Install the tube gasket to the cover.

5-4. Valve seal, valve retaining gasket (Air cushion style only)

By referring to Figure 4, install them to the specified position.

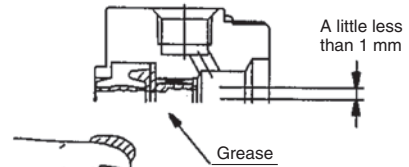

Fig. 8 Rod seal

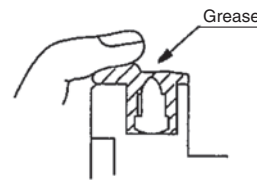

Fig. 9 Piston seal

Series CG5-S

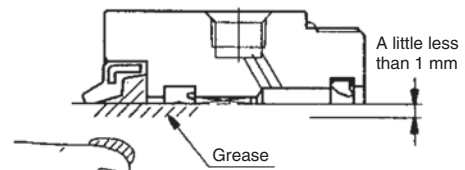

Fig. 10 Rod seal

⚠ Caution

Make sure that there is nothing wrong with operation and air leakage when assembly is completed.

1. Disassembly of the Cylinder

The cylinder needs to be disassembled and assembled in a clean place.

Series MB/MB1

For work tools, refer to the Table 1.

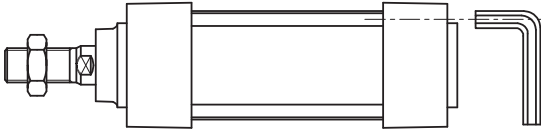

Table 1 Work tools

Bore size	Width across flats of a hexagon wrench	
	When removing the support bracket	When removing the tie-rod nut
32, 40	4	6
50, 63	5	8
80, 100	6	10
125	8	12

Series CA2

For work tools, refer to the Table 2.

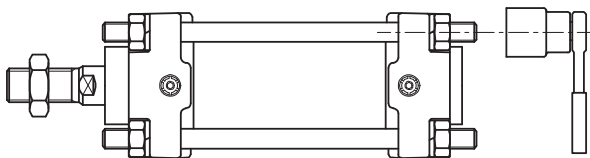

Table 2 Work tools

Bore size	Applicable socket
40, 50	13 (M8)
63	17 (M10)
80, 100	19 (M12)

2. Removal of the Seal

2-1. Rod seal, cushion seal

Insert a watchmakers screw driver to pull out the seals.

Take care not to damage the seal groove of the cover. (Fig. 1)

2-2. Piston seal

Remove it as in Fig. 2.

2-3. Tube gasket

Remove it in the same way as Fig. 2.

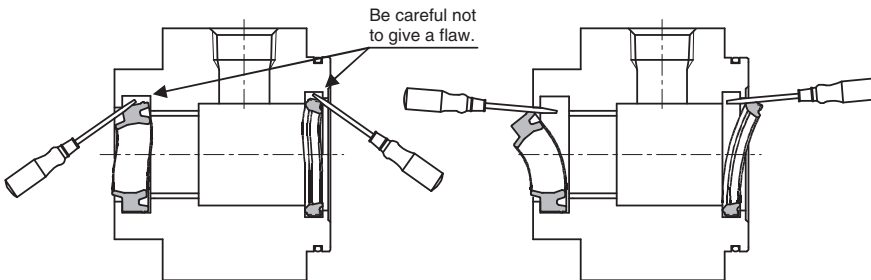

Fig. 1 Removal of rod seal and cushion seal

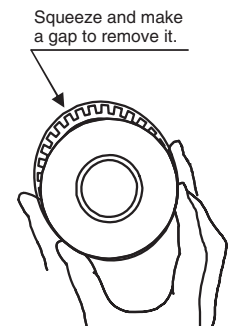

Fig. 2 Removal of piston seal

3. Application of Grease to Seal

- 3-1. Apply grease slightly to the outer circumference of each seal.
- 3-2. Fill in the groove of the rod seal with grease.

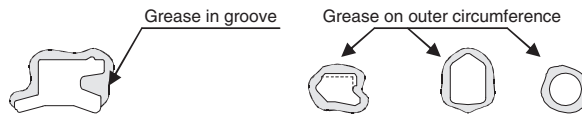

Fig. 3 Grease to the seals

4. Mounting of Seal

- 4-1. Rod seal, cushion seal
Mount the seal in the correct direction by bending the seal with fingers as Fig. 4.
- 4-2. Piston seal
Mount the seal while stretching it as in Fig. 5.

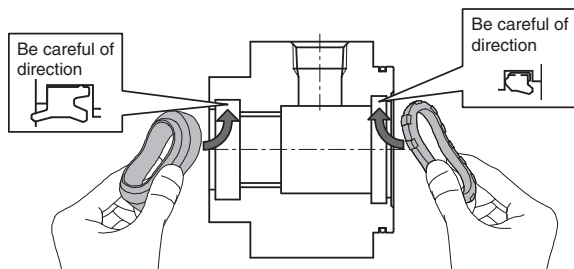

Fig. 4 Mounting of rod seal, cushion seal

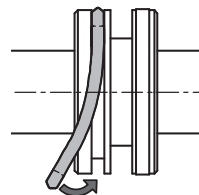

Fig. 5 Mounting of piston seal

5. Application of Grease

- 5-1. Rod seal, cushion seal
Apply grease to the seal and the inner circumference of the bush. (Fig. 6)
- 5-2. Piston seal
Rub grease into the seal groove and the outer circumference of the seal. (Fig. 7)
- 5-3. Cylinder component parts
Apply grease to each component parts of the cylinder in Figure 9. Appendix table shows the grease amount required for a cylinder with stroke 100. For your reference, amount taken with a forefinger is about 3 g. (Fig. 8)

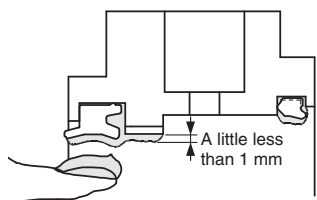

Fig. 6 Rod seal
Cushion seal

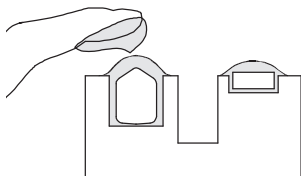

Fig. 7 Piston seal

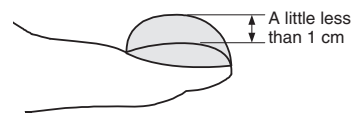

Fig. 8 Grease amount

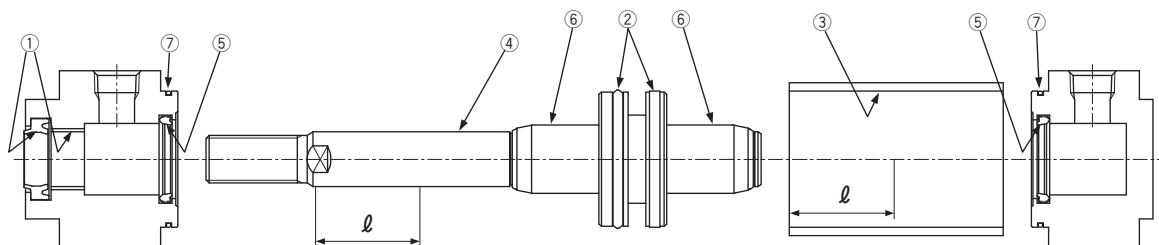

Fig. 9 Grease application points

$$l = \frac{\text{STROKE}}{2} \text{ or } 100 \text{ mm and more}$$

Actuators

Modular F.R.L.
Pressure Control Equipment

Air Preparation
Equipment

Industrial Filters

Replacement
Procedure

Actuators

Modular F.R.L.
Pressure Control Equipment

Industrial Filters

Series MB/MB1/CA2 Replacement Procedure of Seal 3

Table 3 Grease application amount (g)

Stroke	Bore size							Application points
	32	40	50	63	80	100	125	
100 st	3 to 4	3 to 4	3 to 5	4 to 5	6 to 8	8 to 10	15 to 17	①②③④⑤⑥⑦
Extra 50 st	1	1	1	1.5	1.5	2	3	③④

6. Reassembly of the Cylinder

- 6-1. Make sure no particles are present. Do not scratch the seals.
- 6-2. To assemble the tie rod to the cylinder, tighten the tie rod to the shorter screw side by hand.
- 6-3. Set the tie rod nuts from the cover on the opposite side. Tighten the tie rod nut so that the tensile force is even.
Refer to the appropriate tightening torque of table 4 and 5.
Brackets refer to the same table.

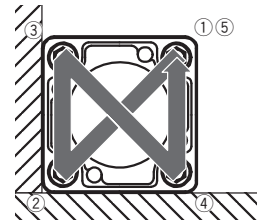

Fig. 10 Tie rod tightening order

Series MB/MB1

Table 4 Appropriate tightening torque

Bore size	Appropriate tightening torque (N·m)
32, 40	5.1
50, 63	11.0
80, 100	25.0
125	30.0

Series CA2

Table 5 Appropriate tightening torque

Bore size	Appropriate tightening torque (N·m)
40, 50	10.8
63	24.5
80, 100	38.2

1. Disassembly

- 1-1. Disassembly should be done in a wide space containing little dust.
- 1-2. After removing the cylinder, be sure to protect the end of piping port and rubber hose on the machine side with clean waste to prevent dust from entering.
- 1-3. Disassemble the unit with care to prevent damage to the sliding portion.
- 1-4. Check the double chamfered portion at the rod end for burrs to prevent damage to the seal and the bushing when removing the cover (push plate) from the piston rod. If burrs are found, remove them with a "file".
- 1-5. Loose either of nuts for tie rod with "ratchet handle for socket wrench", "T-type slide handle for socket wrench" or "spinner handle for socket wrench", etc. and remove it from the tie rod. Please refer to the table for "socket for socket wrench".

Series CS1		
Bore size (mm)	Nut	Applicable socket
125, 140	Class1, M14 x 1.5	JISB4636 Dodecagon 22
160	Class1, M16 x 1.5	JISB4636 Dodecagon 24
180	Class1, M18 x 1.5	JISB4636 Dodecagon 27
200	Class1, M20 x 1.5	JISB4636 Dodecagon 30
250	Class1, M24 x 1.5	JISB4636 Dodecagon 36
300	Class1, M30 x 1.5	JISB4636 Dodecagon 46

Series CS2		
Bore size (mm)	Nut	Applicable socket
125, 140	Class2, M14 x 1.5	JISB4636 Dodecagon 22
160	Class2, M16 x 1.5	JISB4636 Dodecagon 24

- 1-6. Remove 4 tie rods from cover.
- 1-7. Remove the push plate (rod cover) from the piston rod with care to prevent damage to the seal and bushing.
- 1-8. Pull the piston rod and pull out the piston from the cylinder tube.
- 1-9. Remove the cylinder tube from the head cover.
- 1-10. Disassembly of the rod cover (For the head cover, it should also be in accordance with this procedure.)

- | Series CS1 | | | | | | | | | | | | | |
|--|---|------------------------|-------------------------------|------------------------|---------------|-----------------|---|----------|-----------------|---|----------|------------------|----|
| <ol style="list-style-type: none"> a. Remove the cylinder tube gasket. When excessive deformation or cut is found with the gasket, replace it. b. Remove the cushion cover from the cover by using "flat blade screwdriver".
(Tool; Screwdriver Nominal size 8 x 150 Normal type, Normal class) c. Remove the cushion valve seal from the cushion valve by using "waste". | <ol style="list-style-type: none"> d. Loosen the hexagon socket head cap screw for push plate by using "hexagon wrench" and remove the push plate. Applicable "Hexagon wrenches" are shown in the table below. <table border="1"> <thead> <tr> <th>Bore size (mm)</th> <th>Hexagon socket head cap screw</th> <th>Nominal size of wrench</th> </tr> </thead> <tbody> <tr> <td>125, 140, 160</td> <td>M8 x 1.25 x 25L</td> <td>6</td> </tr> <tr> <td>180, 200</td> <td>M10 x 1.5 x 30L</td> <td>8</td> </tr> <tr> <td>250, 300</td> <td>M12 x 1.75 x 35L</td> <td>10</td> </tr> </tbody> </table> <ol style="list-style-type: none"> e. Remove the wiper ring. If it cannot be removed by hand, use a small "flat blade screwdriver" and remove it with care to prevent damage to it. f. Remove the rod seal by using a small "flat blade screwdriver" with care to prevent damage to it. g. Remove the push plate gasket. h. Since the cushion seal is pressed fit, air will leak from the portion where the cushion seal is pressed fit due to damage or change in pressing force. Therefore when the cushion seal should be replaced, the rod cover assembly and the head cover assembly should be replaced. (For those that are to be assembled with the Class 2 pressure vessel, the rod and head covers cannot be replaced. Please consult SMC as required.) i. Since the bushing is pressed fit into push plate, it is difficult to remove structurally and even if it is removed, stock for press fit lowers when it is pressed fit again. Therefore when it is replaced, replace the push plate assembly. | Bore size (mm) | Hexagon socket head cap screw | Nominal size of wrench | 125, 140, 160 | M8 x 1.25 x 25L | 6 | 180, 200 | M10 x 1.5 x 30L | 8 | 250, 300 | M12 x 1.75 x 35L | 10 |
| Bore size (mm) | Hexagon socket head cap screw | Nominal size of wrench | | | | | | | | | | | |
| 125, 140, 160 | M8 x 1.25 x 25L | 6 | | | | | | | | | | | |
| 180, 200 | M10 x 1.5 x 30L | 8 | | | | | | | | | | | |
| 250, 300 | M12 x 1.75 x 35L | 10 | | | | | | | | | | | |

- | Series CS2 | |
|--|--|
| <ol style="list-style-type: none"> a. Remove the cylinder tube gasket. When excessive deformation or cut is found with the gasket, replace it. b. Pick out the rod seal with a small flat blade screwdriver carefully not to damage seal and rod cover. c. Remove the cushion seal from the cover by using a small flat blade screwdriver carefully not to damage seal and rod cover. d. The bushing is pressed fit to the rod cover and difficult to remove. Even if it can be removed, the allowance for press-fit is reduced, which requires the replacement as a rod cover assembly. | |

Series CS1/CS2 Replacement Procedure of Seal 2

2. Replacement Procedure of Seal

2-1. Removal of the seal

Please refer to “1. Disassembly” for dismantling of wiper ring, rod seal, valve seal, tube gasket and push plate gasket.

Since piston seal has a deep groove for sealing, use your hand (not a watchmakers screw driver) and push from one side of seal and pull it out when it lifts off.

2-2. Application of grease

- a. Seal: Apply thin coat of grease.
- b. Cylinder component

Apply grease to the individual components as the figure below. The table shows the grease amount required for a cylinder with stroke 100.

Series CS1

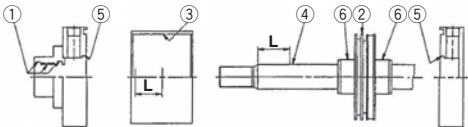

Grease application amount (g)

Bore size (mm)	125	140	160	180	200	250	300	Portion to apply
100st	15 to 17	20 to 22	24 to 26	27 to 29	30 to 32	33 to 35	36 to 38	① to ⑥
50st extra	3	3	3	4	4	5	5	③④

For grease, use lithium soap group grease JIS #2.

Series CS2

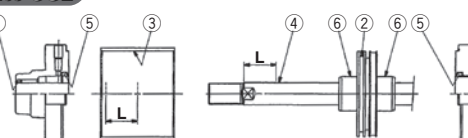

$$L = \frac{\text{STROKE}}{2} \text{ or } 100 \text{ mm and more}$$

Grease application amount (g)

Bore size (mm)	125	140	160	Portion to apply
100st	15 to 17	20 to 22	24 to 26	① to ⑥
50st up	3	3	3	③④

For grease, use lithium soap group grease JIS #2

2-3. Mounting of seal

Series CS1

- a. Wiper ring/Rod seal
Mount in correct direction.
- b. Seals other than wiper ring
After mounting seals, apply grease on inside diameter surfaces of bushing (rubbing grease into surface).

Series CS2

- a. Cushion seal/Rod seal
Mount in correct direction. N
- b. Seals other than rod seal and cushion seal (Mounting directionless seals)
After mounting seals, apply grease on inside diameter surfaces of bushing (rubbing grease into surface).

3. Assembly

- 3-1. Before assembling cylinder, be sure to clean each part to remove dust.
- 3-2. Before assembling, apply rod, bushing, tube and seal with enough grease.
- 3-3. For rusty part, remove the rust completely.
- 3-4. Assembly should be done in a clean place with care to prevent foreign matters from entering.
- 3-5. Mount seal with care to prevent damage to it.
- 3-6. Insert piston into tube or rod into bushing with care to prevent damage to each seal.
- 3-7. Tighten tie rod and bolt with appropriate torque shown in the table below.

Series CS1

Tightening torque (N·m)

Bore size (mm)	125	140	160	180	200	250	300
Tie rod	Steel tube	49	75.5	103	147.1	254	451.1
	Aluminum tube	39.2	62.8	92.7	132.4	-	-
Push plate bolt	11		22		38		

Series CS2

Tightening torque (N·m)

Bore size (mm)	125	140	160
Tightening torque	39.2	62.8	

Series CUJ Replacement Procedure of Seal 1

1. How to Disassemble

1-1. Disassembly

a. $\phi 4$ to $\phi 10$

Lightly hold the cylinder tube in a vice. Use a spanner on the width across flats of the rod cover and turn it counterclockwise to detach the rod cover.

b. $\phi 12$ to $\phi 20$

Remove the retaining ring with suitable pliers (tools for basic internal retaining ring).

Moreover, please note that the retaining ring comes off from pliers when detaching it, it flies, and the human body and peripherals might be disadvantaged.

1-2. Removal of existing seal

For piston seal and tube gasket (O-ring), pick their edges and pull them out of groove.

For rod seal, use a fine watchmakers screw driver to remove it from the seal groove. At that time, be careful not to scratch the inside of the groove and bearing.

2. How to Assemble

2-1. Mounting of seal

a. Tube gasket (O-ring)

Spread the surface of tube gasket with special grease included in a packing set and mount the gasket in the specified groove. (For double acting cylinders only.)

b. Piston seal

Fill a concavity at the side of piston seal with the special grease. Then, mount the seal in the specified groove without a twist.

c. Rod seal

Spread the entire rod seal and fill U-shape groove with the special grease. Then, mount the

rod seal in the specified groove. Make sure to mount it in the right direction. (For double acting cylinders only.)

2-2. Application of grease to cylinder tube

It is recommended that grease should be applied to cylinder tube in case of seal replacement.

Wipe existing grease with clean waste. Be careful not to scratch the inside of cylinder tube and leave out any fiber of the waste as well. Air leakage may occur otherwise.

2-3. Assembly

a. $\phi 4$ to $\phi 10$

After attaching piston rod assembly to rod cover assembly, set them into cylinder tube.

Tighten the rod cover with the torque specified below.

Tightening torque

$\phi 4$	$\phi 6$	$\phi 8$	$\phi 10$
0.97 N·m ± 10%	3.08 N·m ± 10%	5.02 N·m ± 10%	5.63 N·m ± 10%

b. $\phi 12$ to $\phi 20$

After connecting the piston rod assembly to rod cover assembly, set them into cylinder tube, and install the retaining ring with proper pliers (tool for installing a basic internal retaining ring).

Pay attention that the ring will slip off from the pliers, and cause injury or damage to peripheral equipment. Additionally, ensure the retaining ring is mounted properly into the retaining ring groove.

3. Inspection

Inspect cylinders with replaced seal for proper operation and air leakage so as to confirm there is no defect before use.

Actuators

Modular F.R.L.
Pressure Control Equipment

Air Preparation
Equipment

Industrial Filters

Replacement
Procedure

Actuators

Modular F.R.L.
Pressure Control Equipment

Industrial Filters

Disassembly/Reassembly

Disassemble and assemble the cylinder in a clean area. Perform on a clean cloth.

For disassembling, hold the flats of the tube cover gently in a vice and hold the flats of the rod cover with a spanner or monkey wrench to loosen and remove the rod cover. When reassembling, tighten 2 degrees more than the original position before disassembling.

Caution

1. For installation and removal, use an appropriate pair of pliers (tool for installing a C retaining ring).

Even if a proper plier (tool for installing a C retaining ring) is used, it is likely to inflict damage to a human body or peripheral equipment, as a retaining ring may be flown out of the tip of a plier (tool for installing a C retaining ring). Be much careful with the popping of a retaining ring. Besides, be certain that a retaining ring is placed firmly into the groove of rod cover before supplying air at the time of installation.

2. Only people who have sufficient knowledge and experience are allowed to replace seals.

The person who disassembles and reassembles the cylinder is responsible for the safety of the product.

3. When replacing seals, take care not to hurt your hand or finger on the corners of parts.

Series CBQ2

When more grease is needed due to the maintenance of the cylinder, etc., please order grease pack, which is available separately.

Lock holder mounting bolt is included for $\phi 20$ to $\phi 63$. Be sure to exchange it when disassembling and re-assembling the cylinder, or it may cause of the air leakage.

1. Disassembly of the Cylinder

See the structural drawing and structural parts for disassembly.

1-1. Cleaning of external surface

Remove dusts and foreign matters from external surfaces to prevent them from entering the cylinder during disassembly. In particular, the surface of the piston rod and the collar should be cleaned carefully.

1-2. Removal of retaining ring

Use appropriate pliers (tool for basic internal retaining ring) for removing the retaining ring. Pay attention that the ring will slip off from the end of the pliers, and cause injury or damage to peripheral equipment.

Series CQ2K

Removal of the rod cover holding bolt and collar holding retaining ring.

a. Bore size $\phi 12$ to $\phi 32$

Remove the hexagon socket head cap screw holding the rod cover with a hexagon wrench.

b. Bore size $\phi 40$ to $\phi 63$

Remove the retaining ring with pliers (tool for basic internal retaining ring), and remove the hexagon set screw on the side of the cylinder tube with a hexagon wrench (2mm width across flats). Be careful not to let the ring slip from the end of the pliers as it may cause injury or damage to surrounding equipment.

1-3. Disassembly

Pull out the rod cover and collar through the bolt or nut mounted on the piston rod end, and take the collar out from the piston rod. At that time, take care not to damage the internal surface of the cylinder tube and the bushing of the collar.

Series CBQ2

a. Removal of the end lock: Fig. 1.

Locking piston seal

Insert the manual bolt and screw it in over the rubber cap of the end lock unit to the internal lock piston. (It is not necessary for \rightarrow L. lock type)

Remove 2 hexagon socket head cap screws and pull off the end lock unit.

As for $\phi 20$ to $\phi 63$, remove locking piston seal.

As for $\phi 80$ and $\phi 100$, remove packing retainer and lock piston seal.

Then remove lock holder mounting bolt and remove the lock unit and gasket.

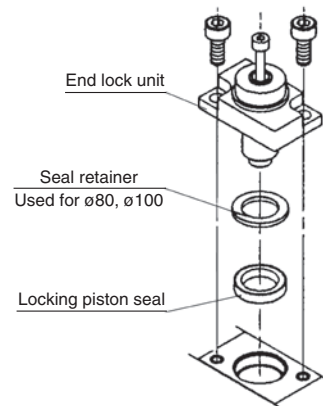

Fig. 1 How to remove end lock

2. Removal of the Seal

2-1. Rod seal

Tool: Watchmakers screw driver, etc.
 Insert a watchmakers screw driver from the front side of the cover as shown in Fig. 2.
 Take care not to damage the seal groove of the cover at this time.

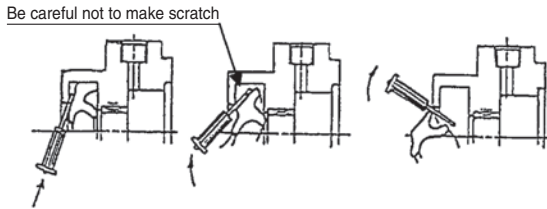

Fig. 2 Removal of Rod packing

Series CQ2

Insert the watchmakers screw driver from the back of the rod cover and collar to pull out the rod seal. Do not damage the seal groove on the collar at this time.

2-2. Piston seal

Wipe off grease around piston seal first to make removal easier.
 Hold piston seal with one hand and push it into groove so that piston seal can be lifted off and pulled out without using a watchmakers screw driver. (Fig. 3)

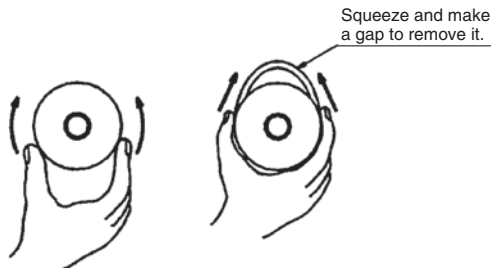

Fig. 3 Piston seal

2-3. Tube gasket

Remove the tube gasket with the watchmakers screw driver or the like.

3. Application of Grease

3-1. Rod seal

Apply grease around the replacement seal. Fill grease in the groove. (Fig. 4)



Fig. 4 Rod seal

3-2. Piston seal

Apply grease thinly and evenly to the external and internal peripheries of the piston seal to ensure easy fitting to the piston.



Fig. 5 Piston seal

3-3. Tube gasket

Thinly apply grease to the tube gasket. Grease will help prevention of dropping off during fitting the cylinder.

3-4. Cylinder parts

Apply grease to all points of cylinder parts as shown in Figure 6. Grease in quantities show in Table 1 are required for each of 100 mm stroke cylinders in accordance with their diameters.
 The quantity of grease taken up by the forefinger as shown in Figure 8 is approximately 3 g.

$$L \approx 100 \text{ mm or Stroke} \times \frac{1}{2}$$

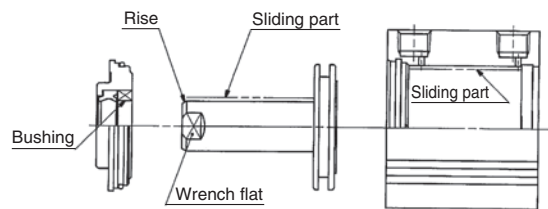

Fig. 6 Grease application points

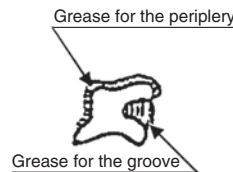

Fig. 7



Fig. 8 Grease amount

Table 1 Grease application amount

Stroke	Bore size (mm)	20	25	32	40	50	63	80	100
	100 stroke		2	3	3	3 to 4	3 to 5	4 to 5	6 to 8
Additional 50 stroke		0.5	0.5	0.5	1	1	1.5	1.5	2

(g)

b. Apply grease to the sliding part of each part.

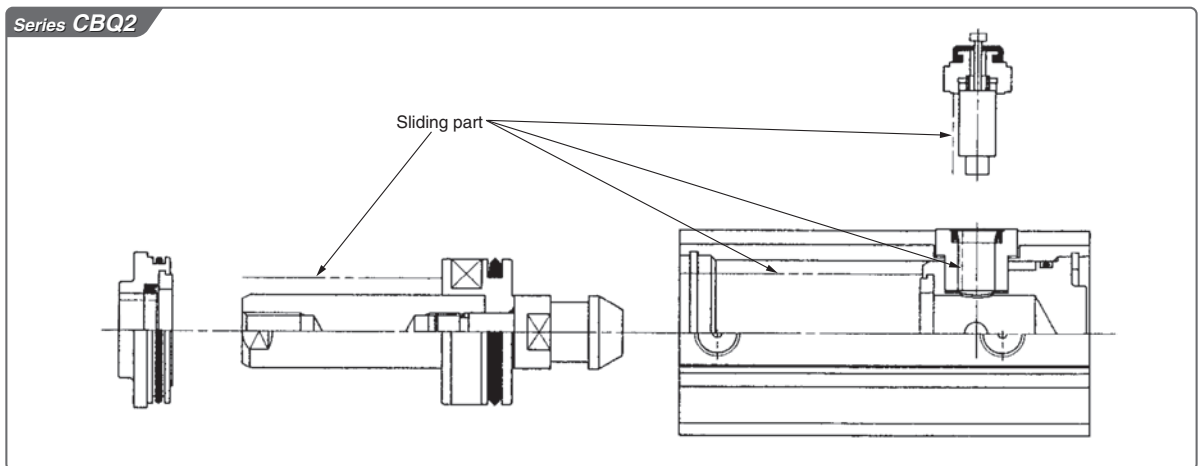
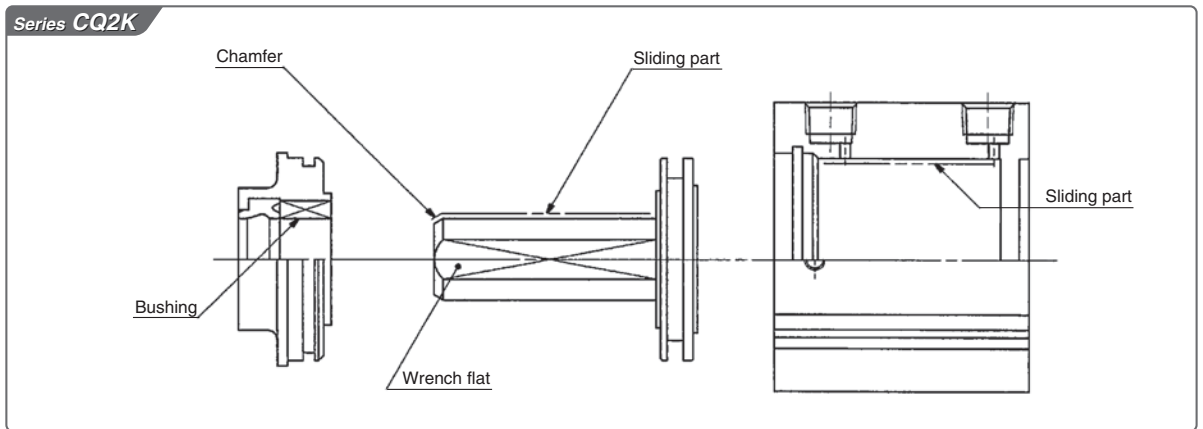
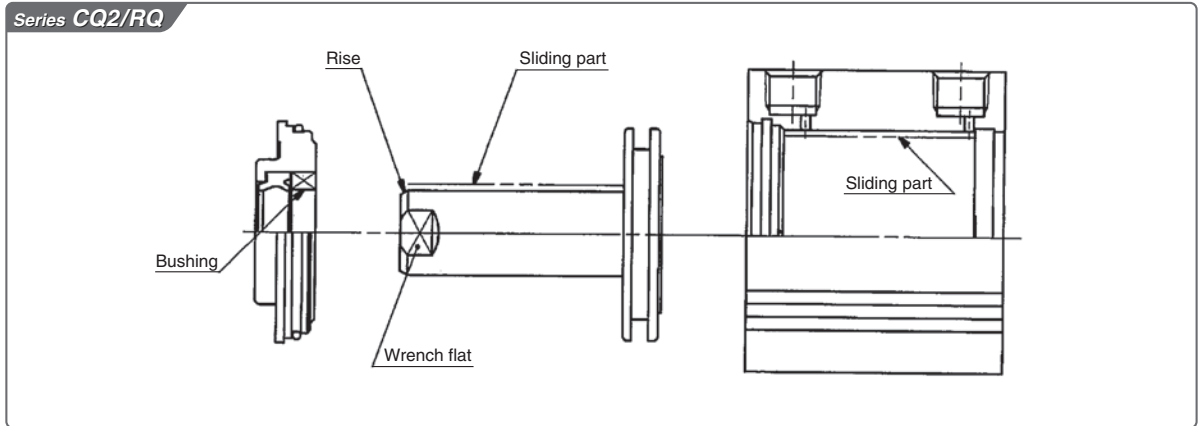

4. Mounting of Seal

4-1. Rod seal

Mount the seal in the correct direction.
 After mounting, apply grease to the seal and bushing evenly.
 For small diameter cylinders, apply grease using the watchmakers screw driver.

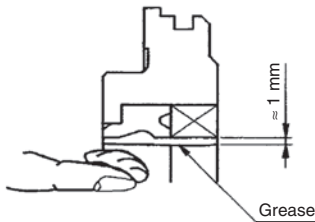

Series CQ2K

To mount the rod seal in the correct direction, the whole internal sliding surface of the guide and rod seal should be visible when looking at the rod cover assembly from the piston side.

After mounting, apply grease to the seal and bushing evenly.

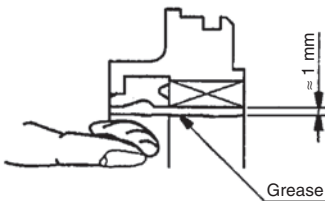

4-2. Piston seal

Mount without twisting. After mounting, apply grease to the external circumference of the seal, and the gap to the mounting groove.



4-3. Tube gasket

Mount the tube gasket on the cover.

5. Reassembly of the Cylinder

- 5-1. Insertion of rod cover and collar to piston rod
Apply grease to the piston rod end or 30° angled raise and wrench flat, and insert the collar gently with care not to damage the rod seal.
- 5-2. Insertion of piston, rod cover and collar to cylinder tube.
Apply grease to appropriate parts of the cylinder tube, and insert the piston and collar gently without any damage to them by the retaining ring groove.

5-3. Mounting of retaining ring

Use appropriate pliers (tool for installing a basic internal retaining ring). Pay attention that the ring will slip off from the pliers, and cause injury or damage to peripheral equipment. Additionally, ensure the retaining ring is mounted properly into the retaining ring groove.

Series CQ2K

- a. Mounting of the rod cover holding bolt and collar retaining ring
- 1) Bore size $\phi 12$ to $\phi 32$
Tighten the hexagon socket head cap screw holding the rod cover with a hexagon wrench to the recommended tightening torque. (Refer to Table for the recommended tightening torque.)
 - 2) Bore size $\phi 40$ to $\phi 63$
Position the collar so that the 4mm hole position on the external circumference aligns with the M4 tap of

the cylinder tube, and tighten the hexagon set screw to the recommended tightening torque. (Refer to Table for the recommended tightening torque.) Use appropriate pliers (tool for installing a basic internal retaining ring). Pay attention that the ring will slip off from the pliers, and cause injury or damage to peripheral equipment. Additionally, ensure the retaining ring is mounted properly into the retaining ring groove.

Bore size (mm)		Rod cover holding hexagon socket head cap screw	Collar holding hexagon set screw	Recommended tightening torque (N·m)
12	Without auto switch	M3 x 0.5 x *L	–	0.59 to 1.06
	With auto switch	M2.5 x 0.45 x 6L	–	0.33 to 0.61
16	Without auto switch	M3 x 0.5 x *L	–	0.59 to 1.06
	With auto switch	M2.5 x 0.45 x 6L	–	0.33 to 0.61
20	Without auto switch	M5 x 0.8 x *L	–	2.84 to 5.10
	With auto switch	M3 x 0.5 x 10L	–	0.59 to 1.06
25	Without auto switch	M5 x 0.8 x *L	–	2.84 to 5.10
	With auto switch	M4 x 0.7 x 10L	–	1.37 to 2.45
32		M5 x 0.8 x *L	–	2.84 to 5.10
40		–	M4 x 0.7 x 4L Truncated cone point	0.20 to 0.39
50		–	M4 x 0.7 x 6L Truncated cone point	0.20 to 0.39
63		–	M4 x 0.7 x 6L Truncated cone point	0.20 to 0.39

* *L: Length of the hexagon socket head cap screw depends on the stroke.

Series CBQ2

a. Mounting of end lock

Apply grease to the lock piston surface and internal lock holder. Insert the gasket and lock holder, then fix with new hexagon socket head cap screw which is attached to the seal kit.

Insert end lock unit and fix with new hexagon socket head cap screw which is attached to the seal kit. (Figure 9, 10, 11, 12)

Tightening torque of bolts for the cap, lock holder

Hexagon socket head cap screw	Applicable bore size	Tightening torque
M3	ø20 to ø63	0.71 to 0.86
M5	ø80 and ø100	2.65 to 3.24

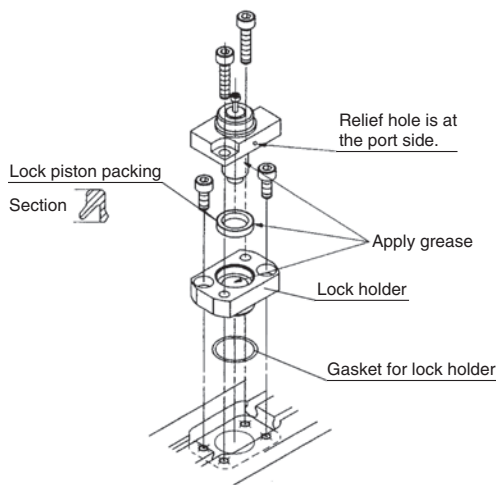

Fig. 9 Reassembling of end lock part (ø20, ø25)

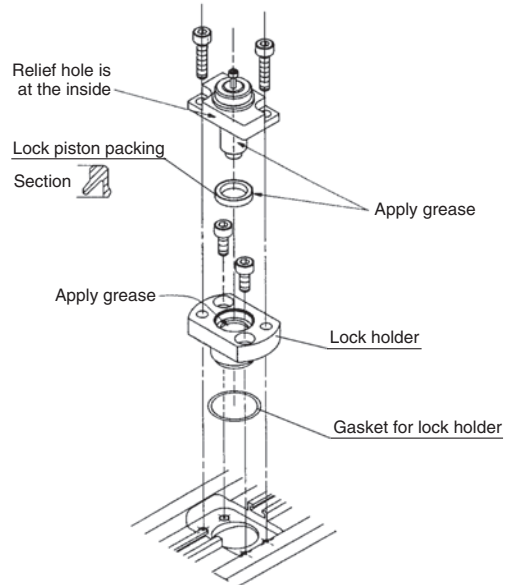

Fig. 10 Reassembling of end lock part (ø32, ø40)

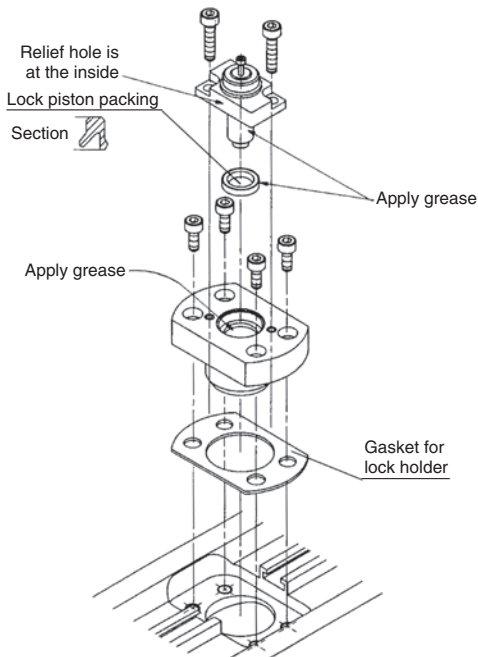

Fig. 11 Reassembling of end lock part (ø50, ø63)

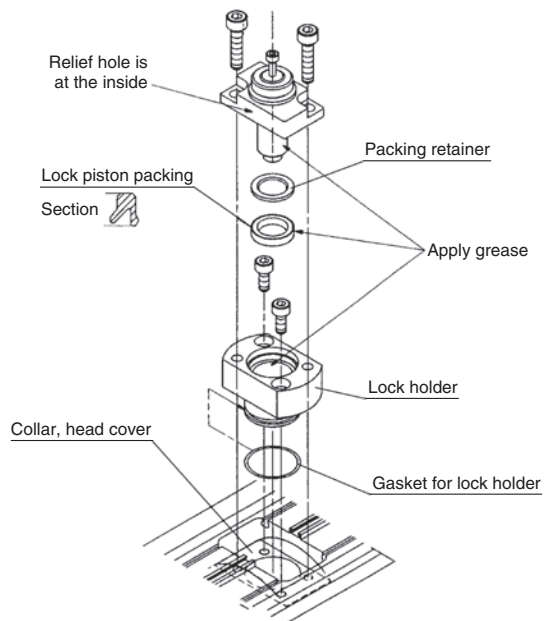

Fig. 12 Reassembling of end lock part (ø80, ø100)

5-4. Check of assembly

Check there is no air leakage at the seal and the minimum operating pressure can realize smooth operation.

Series CXT

Replacement of Driving Cylinder

1. Driving cylinder of this device is normal compact cylinder, so it is possible to replace it. The following is types of cylinder.

Applicable type	Driving cylinder type
CXT□12	CDQSB12-**DC
CXT□16	CDQSB16-**DC
CXT□20	CDQSB20-**DC
CXT□25	CDQSB25-**DC
CXT□32	CDQ2A32-**DC
CXT□40	CDQ2A40-**DC

Driving cylinder type ** indicates stroke.

2. Replacement procedure

Please comply with the following procedure as referring constructions on page 145.

a. Disconnect connection between piston rod²⁴ and adaptor¹⁰ with spanner.

b. Remove 4 bolts fixing plate² to driving cylinder.

Note)

c. Replace driving cylinder to another and fix it with 4 bolts. Please make sure that piston rod²⁴ doesn't touch inside of plate A² hole.

d. Screw adaptor¹⁰ in piston rod²⁴ and tight it with spanner.

Note) In case of cylinder with short stroke, hexagon wrench sometimes doesn't applies between plate A² and slide block¹ due to its narrow space. In that case, replace driving cylinder by removing plate A itself with loosening 2 tightening bolts between plate A and guide axis⁴.

3. In case of replacing only packing etc. of cylinder, replace it after removing cylinder on 2). Please refer to "Appendix. Replacement procedure of cylinder packing"

1. Disassembly of the Cylinder

1-1. Cleaning

Prior to disassembly, wipe off any dirt from the outside of the actuator. This will prevent the intrusion of dust and foreign materials during disassembly.

Take particular care on the surface of the piston rod.

1-2. Removal of switch rail [if the switch is mounted]

Loosen the hexagon bolt and remove the switch rail and switch rail pedestal.

1-3. Removal of rod cover

Series HYQ

Loosen the hexagon socket head cap screw and remove the rod cover.

Series HYC

Loosen the tie rod nut and remove the rod cover.

1-4. Disassembly

Pull out the piston rod by holding a bolt or nut mounted on the piston rod end. Take care not to scratch or mark the internal face of the cylinder tube.

1-5. Removal of the head cover

Series HYQ

Loosen the hexagon socket head cap screw and remove the head cover.

Series HYC

Loosen the tie rod nut and remove the head cover.

2. Removal of the Seal

2-1. Rod seal [Fig. 7]

Insert a watchmakers screw driver etc. from behind the rod cover and prise the seal out. Take care not to scratch or score the seal groove in the rod cover.

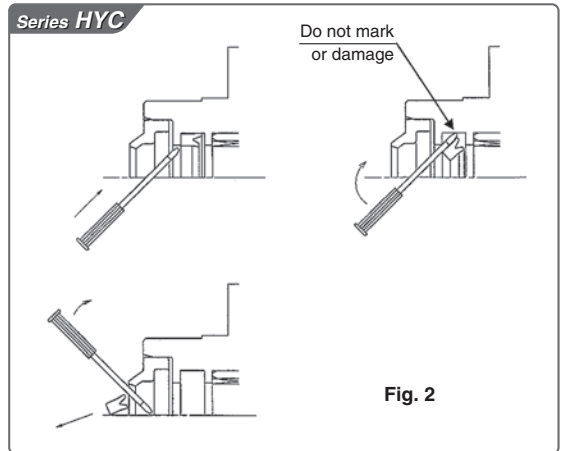
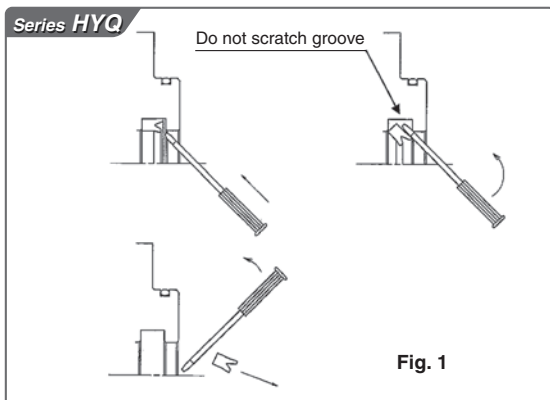

2-2. Cushion seal

Series HYC

Insert a watchmakers screw driver etc. from the front of the rod cover and take out. Take care not to mark or damage the seal groove of the rod cover. Likewise, insert the watchmakers screw driver etc. from the front of the head cover and take out. Do not mark or damage the seal groove of the head cover. (Fig. 3)

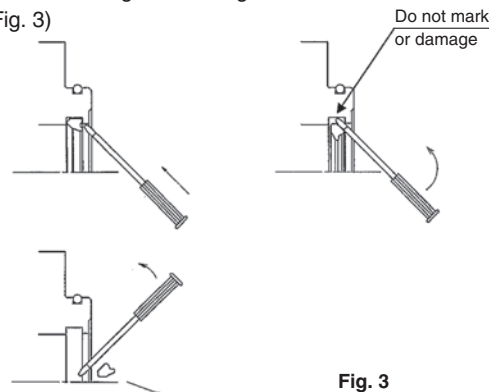

2-3. Piston seal

Since the piston packing is inserted deeply, push it partially to make it come off and pull it out manually. Do not use watchmakers screw driver. (Fig. 4)

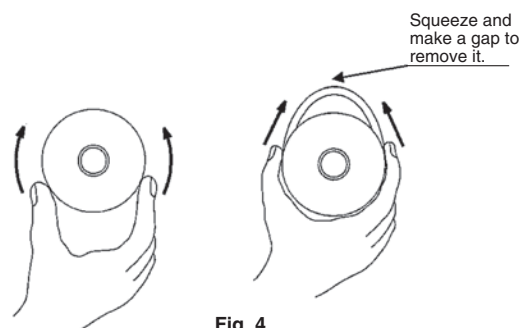

Series *HYQ/HYC* Replacement Procedure of Seal 2

2-4. Tube gasket

Push the tube gasket partially to make it come off and pull it out manually. (Fig. 4)

2-5. Needle scraper

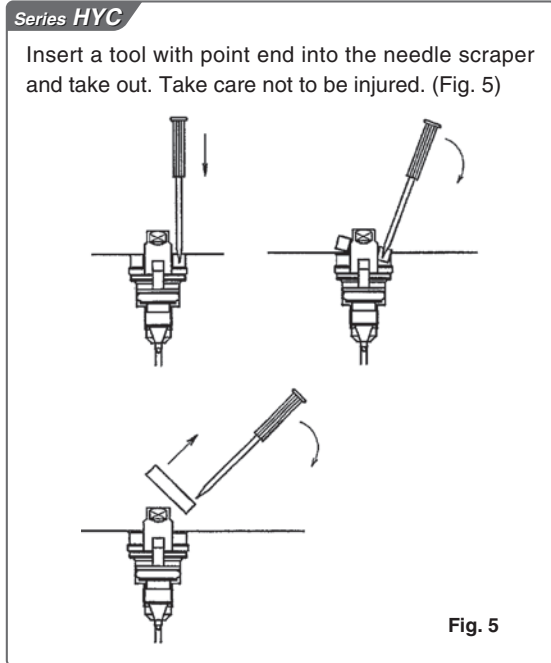

3. Application of Grease

3-1. Rod seal and piston seal [Fig. 6, Fig. 7]

Apply the grease all around new packing evenly. Also add the grease inside the groove.

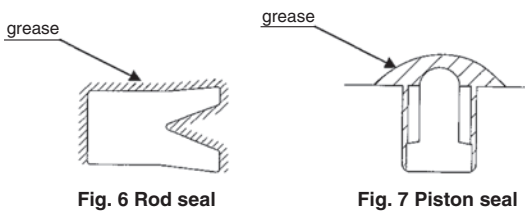

3-2. Cushion seal [Fig. 8]

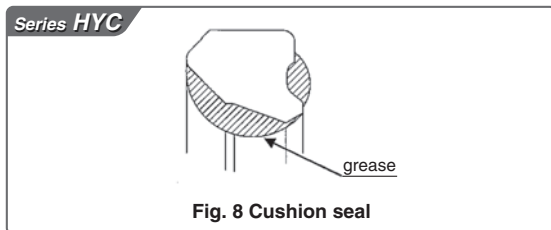

3-3. Tube gasket

Spread a thin film of grease, over the gasket.

3-4. Rod scraper

Fill the rod scraper groove with grease. (Fig. 9)



Fig. 9

3-5. Each component of the cylinder

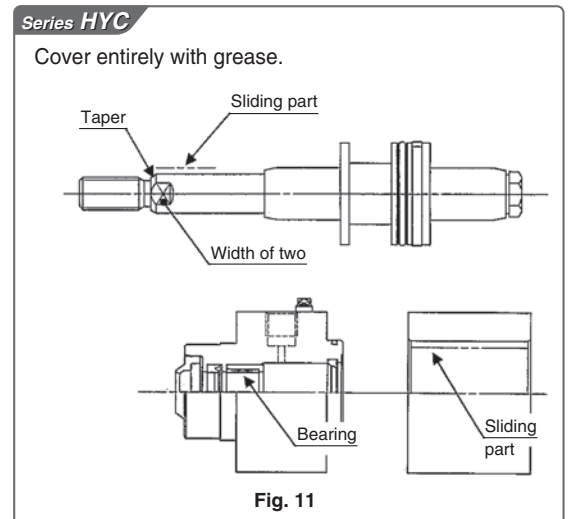
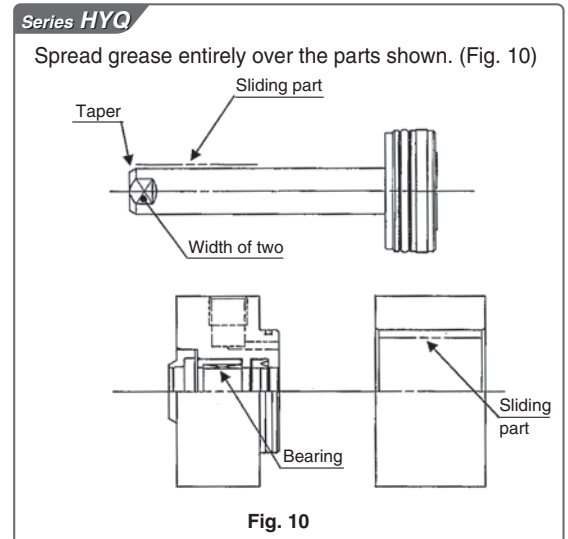

4. Mounting of Seal

4-1. Rod seal

Mount the seal with attention to direction.
Then, apply the grease on the seal and bearing evenly.

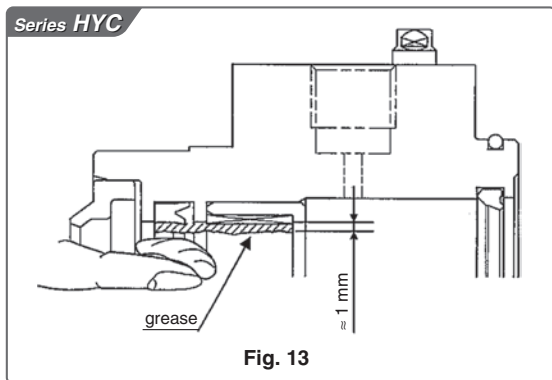
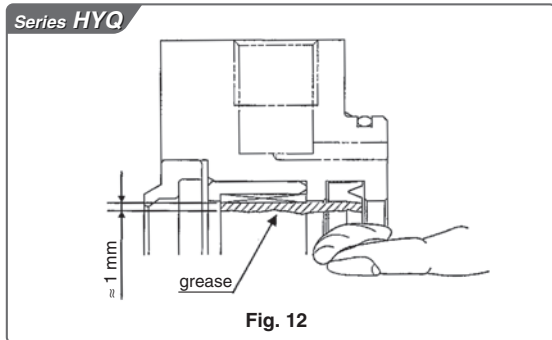

4-2. Piston seal

Make sure not to twist the seal, when mounting.

4-3. Cushion seal

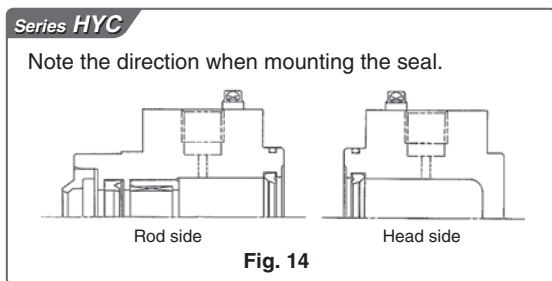

4-4. Tube gasket

Pay attention not to make the gasket come off.

4-5. Needle scraper

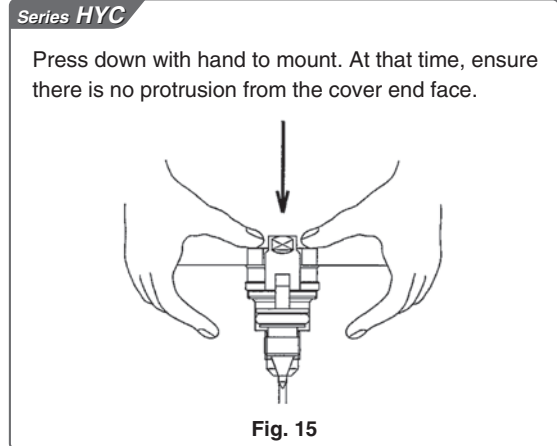

5. Reassembly of the Cylinder

5-1. Tighten the head cover.

Series HYQ

Wipe off the old adhesive from the threaded part of the hexagon socket head cap screw and apply a new layer of adhesive (Loctite 242 (blue)).
Tighten the cylinder tube and head cover with hexagon socket head cap screw.

Table 1

Applicable bore size	Tightening torque (N·m)
ø20	2.1 to 3.9
ø25	3.6 to 6.8
ø32	2.1 to 3.9
ø40	3.6 to 6.8
ø50	8.8 to 16.2
ø63	8.8 to 16.2

Series HYC

Wipe off the adhesive from the threaded part of the tie rod bolt and apply adhesive (Loctite 242 (blue)) newly.
Tighten the cylinder tube and head cover with tie rod bolt.

Table 2

Applicable bore size	Tightening torque (N·m)
ø32	8.8 to 16.2
ø40	17.2 to 31.8
ø50	17.2 to 31.8
ø63	17.2 to 31.8

5-2. Inset the rod assembly into the cylinder tube.

Apply the grease to the part receiving the cylinder tube and insert the rod assembly carefully and slowly make sure the piston packing and gasket are not damaged.

Actuators

Modular F.R.L.
Pressure Control Equipment

Air Preparation
Equipment

Industrial Filters

Replacement
Procedure

Actuators

Modular F.R.L.
Pressure Control Equipment

Industrial Filters

Series *HYQ/HYC* Replacement Procedure of Seal 4

5-3. Tighten the rod cover.

Series *HYQ*

Wipe off the old adhesive from the threaded part of the hexagon socket head cap screw, and apply a new layer of adhesive (Loctite 242 (blue)).

Tighten the cylinder tube and rod cover with hexagon socket head cap screw. (Tightening torque: refer to table 1)

Series *HYC*

Wipe off the adhesive from the threaded part of the tie rod bolt and apply adhesive (Loctite 242 (blue)) newly.

Tighten the cylinder tube and rod cover with tie rod bolt. (Tightening torque: refer to table 2)

5-4. Mount the switch rail (if the switch is mounted).

Applicable bore size	Tightening torque (N·m)
ø20 to ø63	1.1 to 1.9

5-5. Check the assembly condition.

Confirm there is no air leakage from the packing and the cylinder can operate smoothly at minimum operating pressure.

⚠ Caution

Ask SMC for replacing a seal if a tube inside diameter has 40 mm or more.

The cylinder with internal diameter of 40 mm or more has extremely large tightening torque at the rod cover.

Therefore, if the cylinder needs to be disassembled for replacing a seal, ask SMC for the work. SMC can supply a seal kit. However, if the cylinder results in failure or damage after it is disassembled by the other party than SMC, we can't compensate such failure.

1. Disassembly of the Cylinder

1-1. Cleaning

Prior to disassembly, wipe off any dirt from the outside of the actuator.

This will prevent intrusion of dust and foreign materials during disassembly.

Take particular care on the surface of the piston rod and guide rod.

1-2. Removal of the assembly

Fix the chamfer on the piston rod, which is retracted, with a spanner, and remove a fixing bolt from a plate by turning the piston rod.

1-3. Removal of the rod cover assembly

Remove the rod cover assembly by rotating the chamfer on the rod cover.

1-4. Disassembly

Pull out the piston rod by holding a nut mounted on the Tightening bolt end. Take care not to scratch or mark the internal face of the body tube.

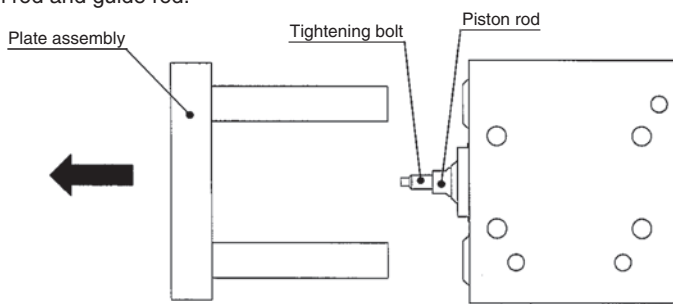

2. Removal of the Seal

2-1. Rod seal

Insert a precision driver etc. from behind the rod cover and prise the seal out. Take care not to scratch or score the seal groove in the rod cover.

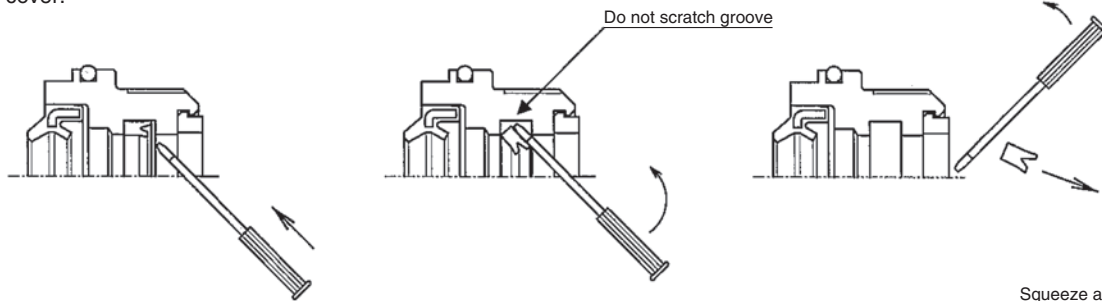

2-2. O-ring (rod side) [Fig. 1]

Push the tube gasket partially to make it come off and pull it out manually.

2-3. Piston seal [Fig. 1]

Since the piston seal is inserted deeply, push it partially to make it come off and pull it out manually. Do not use precision driver.

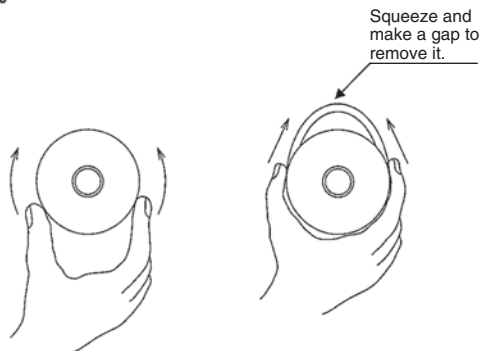

Fig. 1

Actuators

Modular F.R.L.
Pressure Control Equipment

Air Preparation
Equipment

Industrial Filters

Replacement
Procedure

Actuators

Modular F.R.L.
Pressure Control Equipment

Industrial Filters

Series *HYG* Replacement Procedure of Seal ②

3. Application of Grease

3-1. Rod seal and piston seal

Apply the grease all around new seal evenly. Also add the grease inside the groove.

3-2. O-ring (rod side)

Spread a thin film of grease, over the gasket.

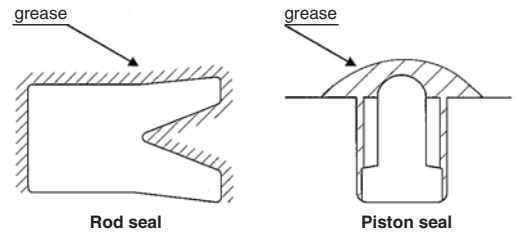

3-3. Scraper

Fill the scraper (part of piston rod and guide rod) groove with grease.

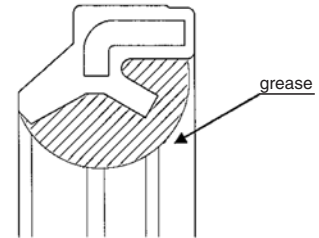

3-4. Each component of the cylinder

Spread grease entirely over the parts shown.

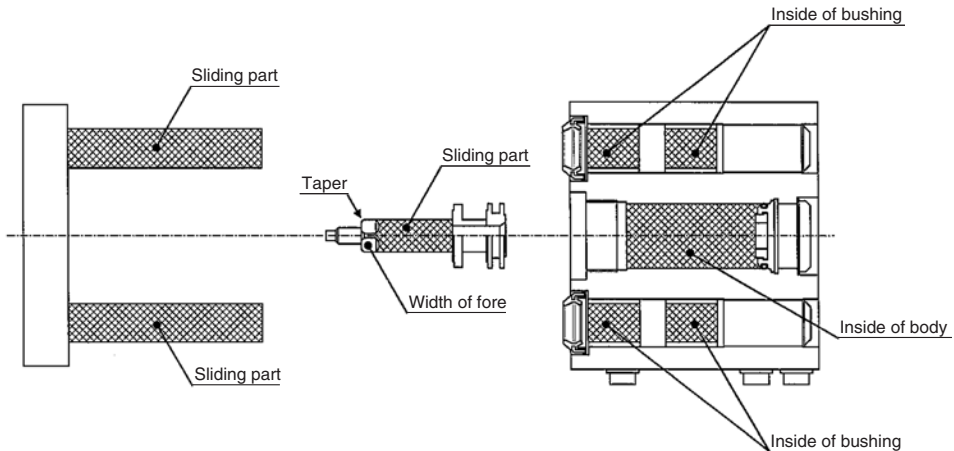

4. Mounting of Seal

4-1. Rod seal

Mount the seal with attention to direction.
Then, apply the grease on the seal evenly.

4-2. Piston seal

When mounting the seal, ensure there are no twists in the seal.

4-3. O-ring (rod side)

Pay attention not to make the gasket come off.

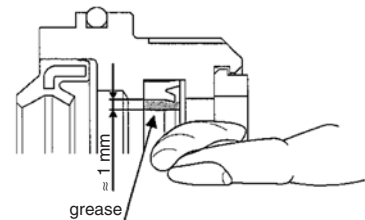

5. Reassembly of the Cylinder

- 5-1. Insert the piston rod assembly into the body.
 Insert the piston rod assembly carefully and slowly, so as not to damage the piston seal.
- 5-2. Tighten the rod cover.
 Tighten the rod cover and the body. (Tightening torque: refer to table 1)
 O-ring must be fit in a groove correctly, and must not be torn out.
- 5-3. Tighten the plate assembly
 Apply adhesive on a thread hole on a plate. (Kind of adhesive: Loctite 262 [red])
 Insert a guide rod of a plate assembly into the body.
 Fixing the chamfer on the piston rod with a spanner, tighten the tightening bolt and the plate assembly by rotating the piston rod.
 (Tightening torque: refer to table 2)
- 5-4. Check the assembly condition.
 Confirm there is no air leakage from the seal and the cylinder can operate smoothly at minimum operating pressure.

Table 1

Bore size (mm)	Tightening torque (N·m)
20	140
25	260
32	500

Table 2

Bore size (mm)	Tightening torque (N·m)
20	2.1 to 3.9
25	3.7 to 6.7
32	8.8 to 16.2

Actuators

Modular F.R.L.
Pressure Control Equipment

Air Preparation
Equipment

Industrial Filters

Replacement
Procedure

Actuators

Modular F.R.L.
Pressure Control Equipment

Industrial Filters

1. Disassembly

- Loosen two set screws at one side. That is, four set screws (within dotted line) both sides totally for three rotations.
- Remove end cover by removing two hexagon socket button head screws for fixing on end cover (at both sides of slider).
- Remove the opposite end cover as same way.
- Remove top cover.
- Pull out dust seal band at this condition.

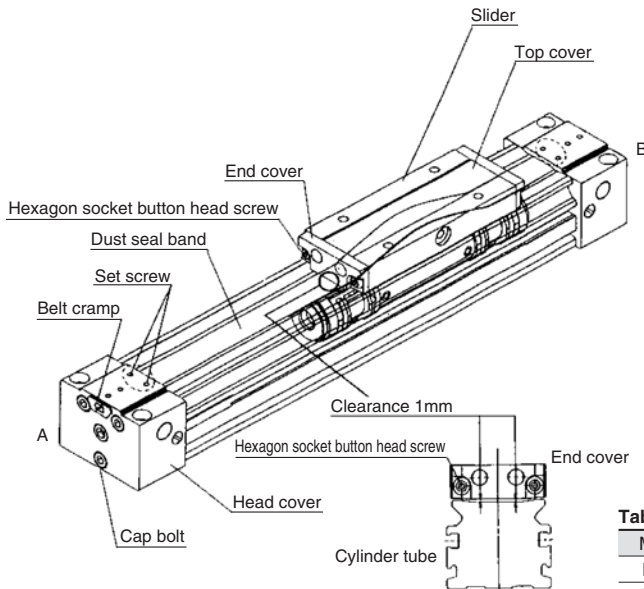
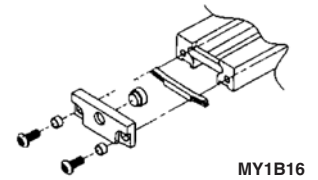

Fig. 1

2. Assembly

- Masking tape (black) of dust seal band for replacement should be removed and applied the grease wholly as Fig. 4^(Note 1) after supplementary process of Fig. 5. (Length of dust seal band is defined as regulated. But check the length again before mounting for shipping.)
- Put dust seal band for replacement in slider.
- Fix end cover assembly so that clearance between end cover assembly and cylinder tube is about 1 mm. In that case, proper tightening torque of hexagon socket button bolt is regulated by values shown in table. 2. Fix the opposite end cover as same way. (Fig. 2) In case of fixing end cover, ensure that spacer, stopper and parallel key are installed.
- Insert both dust seal band into head cover up to line (10 mm). At the same time, put dust seal band in the groove of cylinder tube while stretching dust seal band. Also, as the stainless plate of dust seal band is thin. 0.15 t, be careful not to bend or break in insertion.



MY1B16

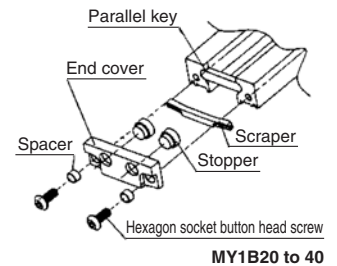

MY1B20 to 40

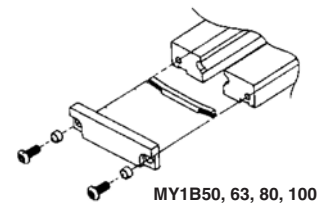

MY1B50, 63, 80, 100

Fig. 2

Table 1. Dust seal band standard list

Model number	Standard length	Model number	Standard length
MY10-16B-st	st + 110 ⁻⁰ / ₀	MY40-16B-st	st + 272 ⁺⁰ / ₀
MY16-16B-st	st + 160 ⁻⁰ / ₀	MY50-16B-st	st + 328 ⁺⁰ / ₀
MY20-16B-st	st + 200 ⁻⁰ / ₀	MY63-16B-st	st + 382 ⁺⁰ / ₀
MY25-16B-st	st + 182 ⁺⁰ / ₀	MY80-16B-st	st + 544 ⁺⁰ / ₀
MY32-16B-st	st + 228 ⁺⁰ / ₀	MY100-16B-st	st + 634 ⁺⁰ / ₀

Note) 2 type of dust seal bands are available and the part no. depends on treatment of setscrew.

- Black zinc chromate → MY**-16B-st
- Nickel plating → MY**-16BW-st

Table 2. Tightening torque of hexagon socket button head screw

Diameter	Bolt size	Tightening torque (N·m)
10		
16, 20	M3 x 0.5	0.3
25, 32, 40	M4 x 0.7	0.7
50, 63, 80, 100	M5 x 0.8	1.5

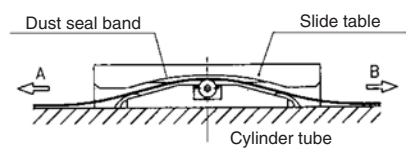

Fig. 3

Series MY1B Replacement Procedure of Dust Seal Band 2

*In case of $\phi 10$, $\phi 80$ and $\phi 100$, Dust seal band is magnetic hold type.

Set the dust seal band on the Cylinder tube with equivalent clearance W_1 and W_2 . (Fig. 5) Another work is same way as above 4.

- e. Tighten only two set screws at A side after installation. In that case, adjust so that dust seal band located near screws does not lift due to excessive tightening. Proper tightening torque is 0.1 N·m {1 kgf·cm}.
- f. Reciprocate slider three or four times up to both stroke ends to remove sagging of dust seal band.
- g. Be sure to return slider up to B side stroke end and tighten at B side as same way after ensuring that dust seal band is inserted into head cover for approx. 10 mm.
- h. Install top cover.
- i. Reciprocate slider for a few times manually again.
If dust seal band does not lift, installation will complete.

Note 1) In case of $\phi 10$, $\phi 80$ and $\phi 100$, dust seal band is made of stainless steel only without masking tape.

Note 2) Apply grease uniformly as Fig. 4. Use lithium soap grease with consistency No. 1 or No. 2.

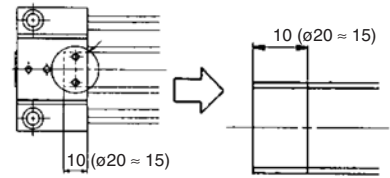

Fig. 4

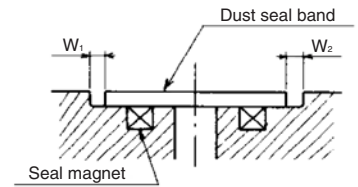

Fig. 5

Actuators

Modular F.R.L.
Pressure Control Equipment

Air Preparation
Equipment

Industrial Filters

Replacement
Procedure

Actuators

Modular F.R.L.
Pressure Control Equipment

Industrial Filters

How to Maintenance

Monthly application of grease to the slide bearing and the dust seal band may lengthen the life.

Grease pack is recommended. (Grease pack number: GR-S-010)

1. Refer to Replacement Procedure of MY1M/C Dust Seal Band.

2. How to install the cylinder with the cover
Refer to Installation Procedure for MY1□W.
3. How to install the side seal of the cylinder with cover.
Refer to Mounting Procedure for MY1□WK side seal.

1. Replacement Procedure of Dust Seal Band

Series MY1M/C

1. Disassembly

- a. Loosen the two set screws at one side, that is, four set screws at both sides.
- b. Remove the end cover by removing two (four) hexagon socket button head screws for fixing which are on the end cover.
- c. Remove the opposite end cover as same way.
- d. Pull out the dust seal band in this condition.

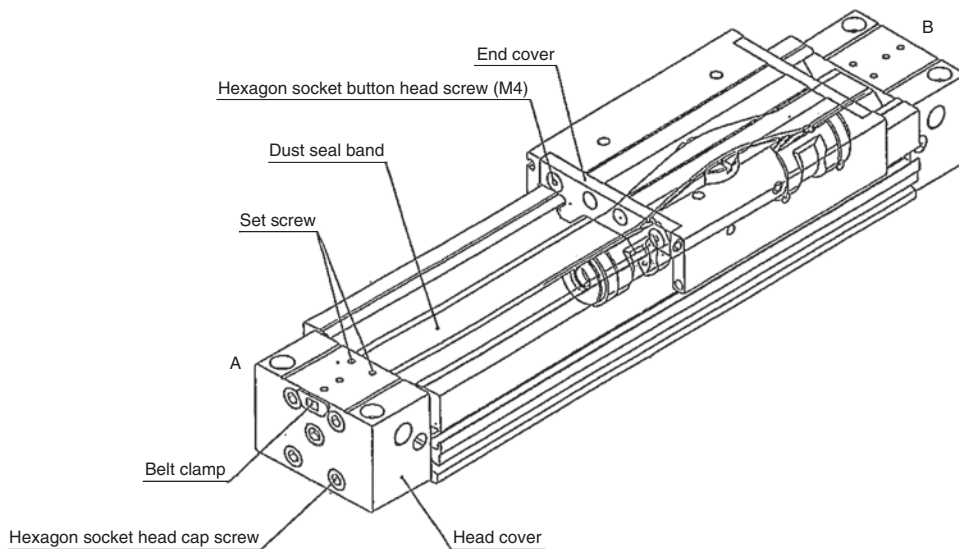

Table. 1 Dust seal band standard list

Model number	Standard length
MY16-16B-st	st + 160 $\begin{smallmatrix} +2 \\ 0 \end{smallmatrix}$
MY20-16B-st	st + 200 $\begin{smallmatrix} +2 \\ 0 \end{smallmatrix}$
MY25-16B-st	st + 182 $\begin{smallmatrix} +2 \\ 0 \end{smallmatrix}$
MY32-16B-st	st + 228 $\begin{smallmatrix} +2 \\ 0 \end{smallmatrix}$
MY40-16B-st	st + 272 $\begin{smallmatrix} +2 \\ 0 \end{smallmatrix}$
MY50-16B-st	st + 328 $\begin{smallmatrix} +2 \\ 0 \end{smallmatrix}$
MY63-16B-st	st + 382 $\begin{smallmatrix} +2 \\ 0 \end{smallmatrix}$

Note) 2 type of dust seal bands are available and the part no. depends on treatment of setscrew.
 Black zinc chromate → MY□□-16B-st
 Nickel plating → MY□□-16BW-st

2. Assembly

- a. The dust seal band for replacement should be added the process of drawing 2 and greased wholly as shown in figure 1.
- b. The dust seal band for replacement is pierced the slide table.
- c. The end cover is fixed so that the clearance between the end cover assembly bottom part and the cylinder tube upper surface is about 1 mm.
The adequate tightening torque at this time is 0.7 N·m (7 kgf·cm).
The opposite end cover is fixed as same way.
- d. The dust seal bands of both sides are inserted in the head cover to the position drawn with a pen (about 10 mm). Then, at the same time, insert the dust seal band in the groove of cylinder tube by pulling it to both sides. (figure 4)
- e. If the dust seal band is installed properly without coming to the surface, tighten two set screws at A side.
Adequate tightening torque is 0.1 N·m (1 kgf·cm).
- f. Reciprocate the slide table three or four times to both stroke ends in order to remove the sag of the dust seal band.
- g. Be sure to return the slide table to B side stroke end and tighten the set screw at B side after ensuring that the dust seal band is inserted in the head cover of about 10 mm.
- h. Reciprocate the slide table again manually a few times and ensure that the dust seal band does not come to the surface.

Note 1) Grease uniformly as the drawing 1. Use consistency No. 1 or No. 2 of the lithium soap grease (such as Mitsubishi Diamond grease multi purpose No. 2).

Table. 2 Tightening torque of button bolt

Diameter	Bolt size	Tightening torque (N·m)
16, 20	M3 x 0.5	0.3
25, 32, 40	M4 x 0.7	0.7
50, 65	M5 x 0.8	1.5



Grease application amount (Shaded portion) ≈ 0.3mm

Fig. 1

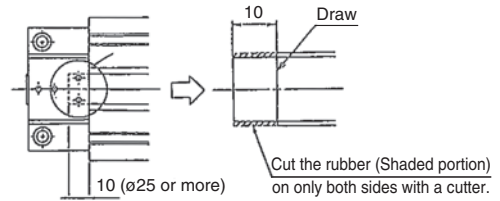

Fig. 2

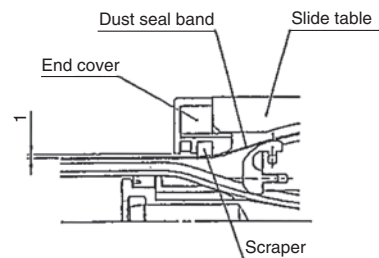

Fig. 3

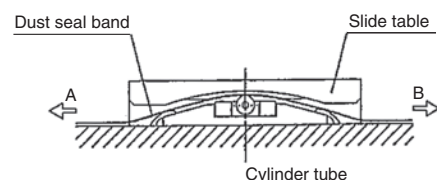
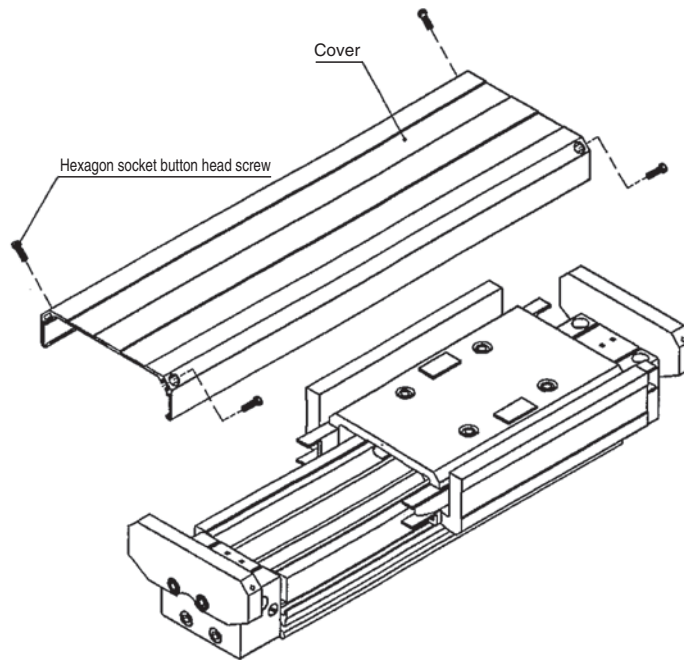

Fig. 4

2. Installation

Series MY1□W

1. Removal of the cover
 - a. Remove the hexagon socket button head screw to remove the cover.



2. Installation, adjustment
 - a. Install the body.
 - b. When the body is equipped only with a cover, the installation is completed when the cover is mounted after the installation and adjustment.

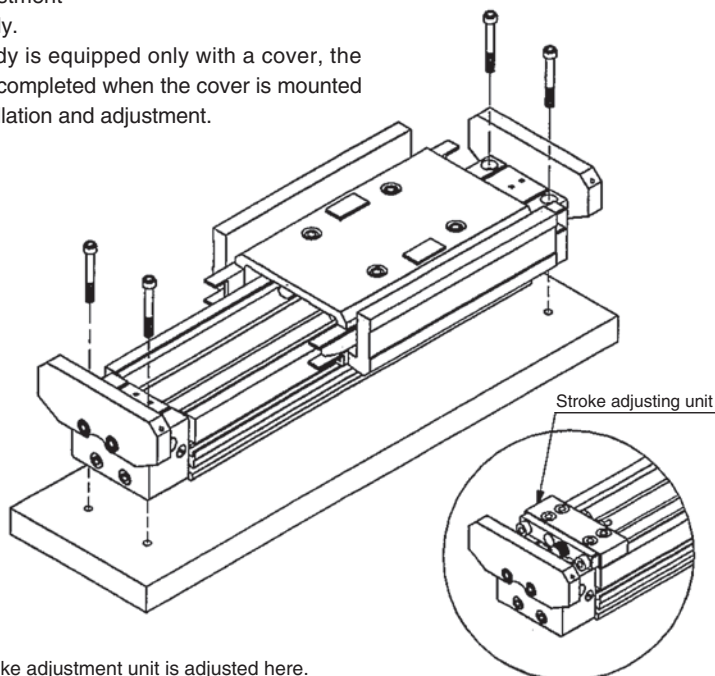

Note) Optional stroke adjustment unit is adjusted here.

3. Installation Procedure of the Side Seal

Series MY1□WK

1. End cover removal procedure

- a. Remove two hexagon socket head cap screws and two hexagon socket button head screws.
- b. Remove the end plate on one end.

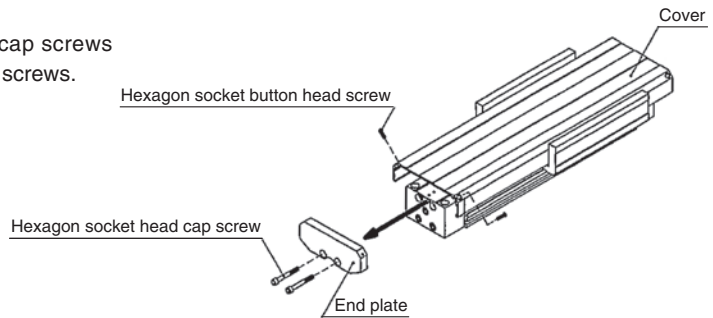

2. Installation of the side seal

- a. Insert the side seal assembly from the end surface.
 Note) The stainless part of the side seal assembly is very sharp. It should be handled with care.

Note) Move the slide table to the end in the retracted direction.

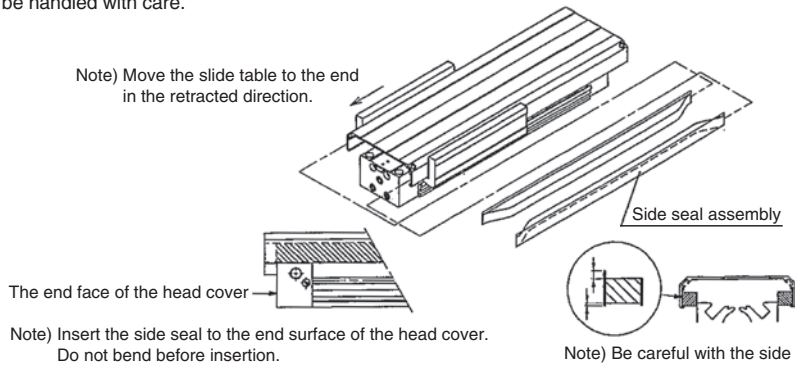

Note) Insert the side seal to the end surface of the head cover. Do not bend before insertion.

Note) Be careful with the side seal assembly direction.

3. Assembly of the cover

- a. Mount the end plate and fix it.

Hexagon socket button head screw

Tightening torque cover (N·m)
(Hexagon socket button head screw)

Torque value	Screw size	Bore size
0.6	M3	All bore common

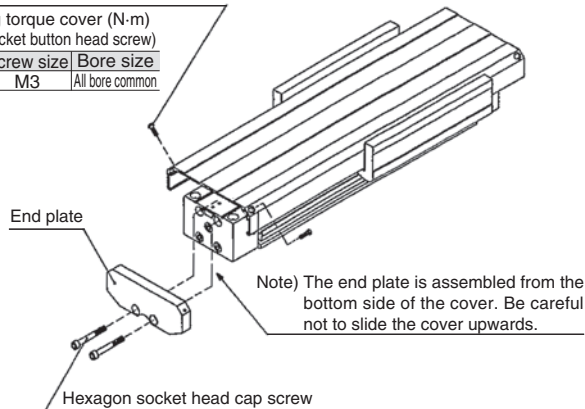

Note) The end plate is assembled from the bottom side of the cover. Be careful not to slide the cover upwards.

Tightening torque cover (N·m)
(Hexagon socket head cap screw)

Bore size	Screw size	Torque value
ø16	M3	0.6
ø20	M4	1.4
ø25	M5	2.8
ø32	M6	4.8
ø40	M6	4.8

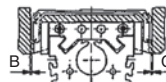

Note) The clearance of B and C part has to be checked at the full stroke. If there is contact, the clearance should be adjusted by loosening the hexagon head cap screw and retightening it.

1. Disassembly

- Loosen the two (three) set screws at one side, that is, four (six) set screws at both sides.
- Remove the end cover by removing two bolt with hex. hole fixing which are on the end cover.
- Remove the opposite end cover as same way.
- Pull out the dust seal band in this condition.

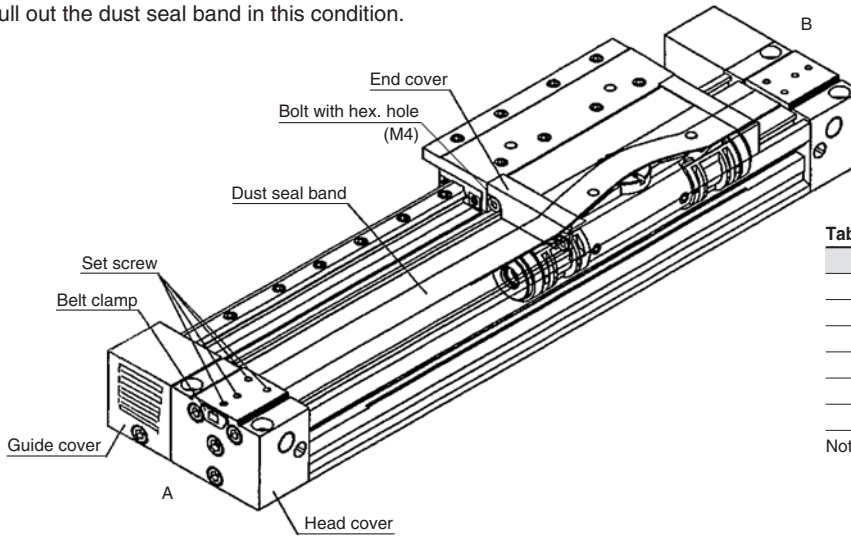

Table 1 Dust seal band standard list

Part number	Standard length
MY10-16B-st	st + 110 ⁺² ₀
MY16-16B-st	st + 160 ⁺² ₀
MY20-16B-st	st + 200 ⁺² ₀
MY25-16B-st	st + 182 ⁺² ₀
MY32-16B-st	st + 228 ⁺² ₀
MY40-16B-st	st + 272 ⁺² ₀

Note) 2 types of dust seal bands are available and the part no. depends on treatment of set screw. (Over $\phi 16$)
 Black zinc chromate → MY**-16B-st
 Nickel plating → MY**-16BW-st

2. Assembly

- The dust seal band for replacement should be greased wholly as shown in figure 1.
- The dust seal band for replacement is pierced the slide table.
- The end cover is fixed so that the clearance between the end cover assembly bottom part and the cylinder tube upper surface is about 1 mm. (fig. 2)
 The adequate tightening torque at this time is 0.7 N·m (7 kgf·cm).
 The opposite end cover is fixed as same way.
- The dust seal bands of both sides inserted in the head cover to the position drawn with a pen (fig. 3). Then, at the same time, insert the dust seal band in the groove of cylinder tube by pulling it to both sides. (fig. 4)
- If the dust seal band is installed properly without coming to the surface, tighten two set screw at A side. Adequate tightening torque is 0.1 N·m (1 kgf·m).
- Reciprocate the slide table three or fore times to both stroke ends in order to remove the sag of the dust seal band.
 Be sure to return the slide table to B side stroke end and tighten the set screw at B side after ensuring that the dust seal band is inserted in the head cover of about 10 mm.

- Note 1) Grease uniformly as the fig. 1. Use consistency No. 1 or No. 2 of the lithium soap grease (such as Mitsubishi Diamond grease multi purpose No. 2).
- Note 2) After inserting the dust seal band, pull it by the hands to A and B directions to make it a little tightened, and insert it to the cylinder tube ditch. (fig. 4)
- Note 3) Adequate tightening torque of the set screw is 0.1 N·m (1 kgf·cm).
- Note 4) Ensure that the magic drawing of additional work to the dust seal band (figure 2) is hidden inside the head cover assembly.

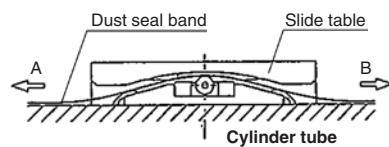
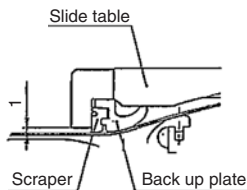
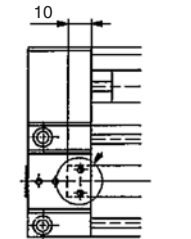
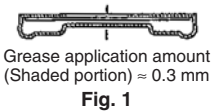

1. Disassembly

- Remove the 4 cap bolts for fixing the cylinder and remove the cylinder from the guide.
- Loosen the 2 set screws on one side (3 screws for $\phi 16$) of the head cover, total 4 screws on both sides (6 screws for $\phi 16$). (Note 1)
- Remove the 2 cap bolts for fixing the end cover to remove the end cover.
- Remove the end cover on the other side in the same way.
- Pull out the dust seal band in this state.

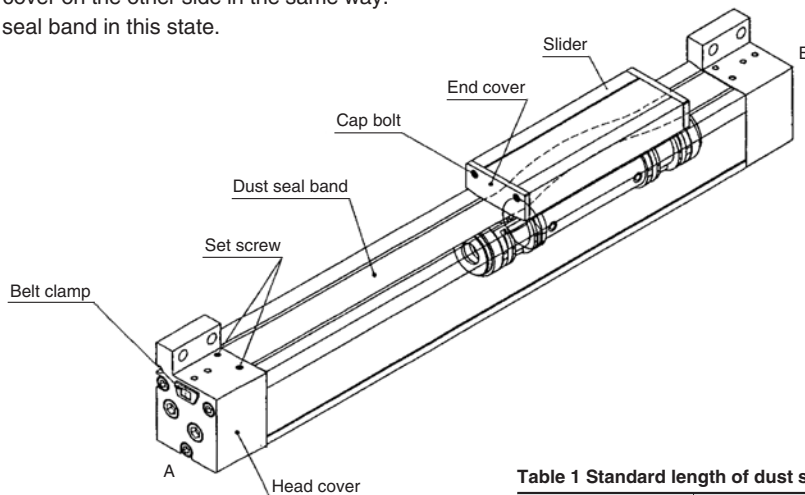
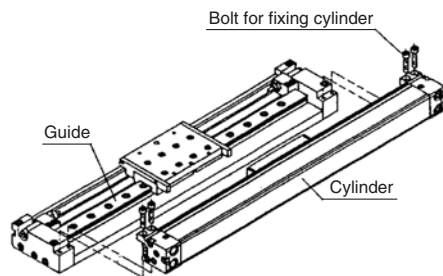

2. Assembly

- Cut the dust seal band for replacement into the dimension shown in Table 1 and bend both ends at about 10° (Figure 2) with L dimension in Table 2 from the position in Figure 1.
- Mount it on the cylinder facing the bent side downward. (Note 2)
- Adjust the end cover to obtain about 1mm clearance between the bottom face of the end cover and the top face of the cylinder tube and fix with care so that the scraper will not drop or twist. (Figure 3)
- Fix the end cover on the other side in the same way.
- Adjust the dust seal band to obtain L dimensions in Table 2 (L dimension: the length of the dust seal band projected from the cylinder tube), and fix the set screws on side A. (Note 3)
- Stretch the dust seal band toward side B and fix it with the set screws on side B.
- Move the slider in full stroke for 2 ~ 3 times to check the dust seal band for fit.
- Apply grease to the sliding part of dust seal band (upper face of the cylinder tube) and mount the cylinder on the guide. (Note 4)

Note 1) For $\phi 16$, remove a belt clamp.

Note 2) Dust seal band is made of thin material. Don't bend it at portions other than those designated.

Note 3) Tightening torque for set screw is 0.1 N·m (1 kgf·cm).

Note 4) For grease, use lithium soap base grease No. 1 or No. 2 (ex. MULTI-PURPOSE No. 2 of MITSUBISHI DIAMOND GREASE)

Table 1 Standard length of dust seal band

Bore size	Standard length
$\phi 16$	Stroke + 160%
$\phi 25$	Stroke + 176%
$\phi 40$	Stroke + 270%

Table 2 L dimension of dust seal band

Bore size	L dimension (mm)
$\phi 16$	20
$\phi 25$	8
$\phi 40$	10

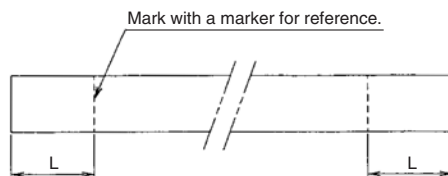

Fig. 1



Fig. 2

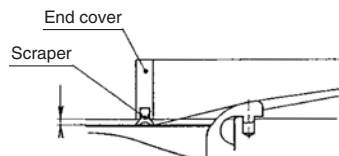

Fig. 3

1. Inspection/Maintenance

Regular grease applying (once a month) to the bearing sliding surface and the dust seal band is recommended for more improvement of life.

Refer to 'Guide for replacement of MY3* dust seal band' to replace the dust seal band.

2. Disassembly/Assembly

Series MY3A/B

Replacement Procedure of Seal Belt

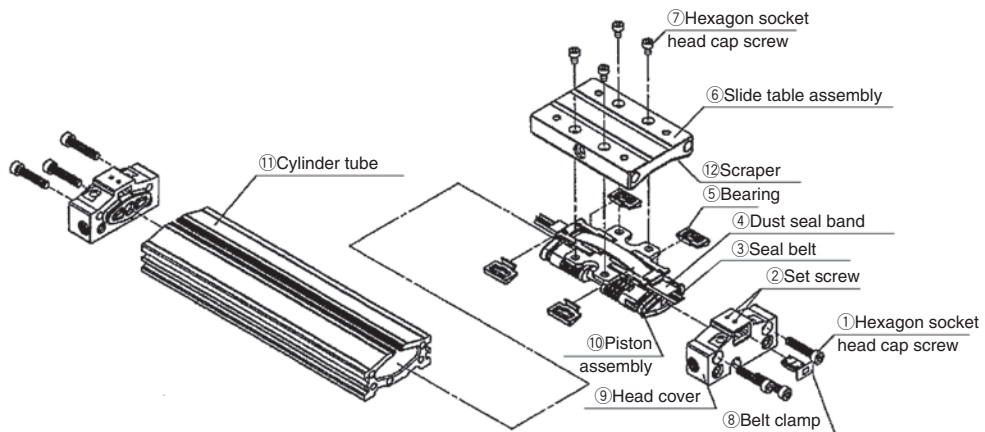

Fig. 1

1. Disassembly

- a. Loosen two setscrews ② on the top head cover ⑨.
- b. Remove belt clamp ⑧.
- c. Remove four retaining hexagon socket head cap screws ⑦ on the top of slide table assembly ⑥.
- d. Remove slide table assembly ⑥. (At this time, please watch that the bearings ⑤ and the scraper ⑫ might fall. (Note 2))
- e. In this condition, Pull out dust seal band ④.
- f. Remove four bearings ⑤ in the right and left from piston assembly ⑩.
- g. Remove three head cover ⑨ retaining hexagon socket head cap screws ①.
- h. Pull out head cover ⑨ from cylinder tube ⑪.
- i. Pull out the other head cover ⑨ from cylinder tube ⑪ in the same method.
- j. Pull out piston assembly ⑩ from cylinder tube ⑪.
- k. Pull out seal belt ③ from cylinder tube ⑪.

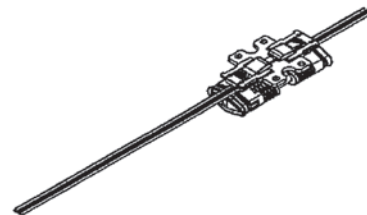

Fig. 2

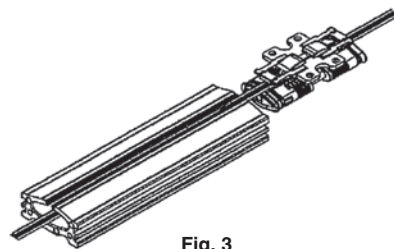

Fig. 3

2. Assembly

- a. Avoid flaws on seal belt, as it may cause air leakage (Pay special attention to the edges indicated by arrows in Figure 4).
- b. Check that the total length of seal belt is of a recommended length and apply grease to the whole surface (Refer to Table 1).
- c. Put seal belt through piston assembly and assemble it to cylinder tube as shown in Figures 2 and 3.
- d. Keep the same extra length of seal belt on both left and right ends of cylinder tube and slowly reciprocate piston assembly once to fit seal belt into cylinder tube. Then reciprocate piston assembly a couple of times more and wipe the extra grease collected forward of the piston off. (When grease remains on the contact side of the piston and the head cover, it may cause the lurching by sticking).
- e. Insert the right and left head cover in the cylinder tube, and tighten head cover retaining hexagon socket head cap screws.
- f. Put dust seal band in piston assembly. (Note 1)
- g. Insert bearing into piston assembly. (Note 1)
- h. Assembly slide table assembly to piston assembly with retaining hexagon socket head cap screws. (Note 1)
- i. Cut off the extra seal belt over the head cover ends with cutter and assembly belt clamp.
- j. Tighten two setscrews each on the top of both head covers. (Note 1)
- k. This is the end of replacement work.
If air leakage is considerable after replacement, consult SMC.



Fig. 4

Table 1. Seal belt part no.

	Bore size	Part No.	Recommended length
MY3A	ø16	MY3A16-16A-st	st + 206
	ø20	MY3A20-16A-st	st + 225
	ø25	MY3A25-16A-st	st + 246
	ø32	MY3A32-16A-st	st + 289
	ø40	MY3A40-16A-st	st + 336
	ø50	MY3A50-16A-st	st + 370
MY3B	ø63	MY3A63-16A-st	st + 416
	ø16	MY3B16-16A-st	st + 218
	ø20	MY3B20-16A-st	st + 245
	ø25	MY3B25-16A-st	st + 274
	ø32	MY3B32-16A-st	st + 321
	ø40	MY3B40-16A-st	st + 372
	ø50	MY3B50-16A-st	st + 406
	ø53	MY3B63-16A-st	st + 452

(Note 1) Refer to "Dust Seal Band Replacement Procedure" for dust seal band assembling (installation of the bearing and the slide table assembly).

(Note 2) When parts fall check no adhesion of the foreign objects and assembly it.

Replacement Procedure of Dust Seal Band

1. Disassembly

- a. Loosen two set screws at one side, that is, four set screws both sides totally for three rotations.
- b. Remove Slide table by removing two hexagon socket button bolts for fixing on Slide table.
Pay attention not to let the bearing and scraper come off when the slid table is removed.
- c. Pull out Dust seal band at this condition.

2. Assembly

- a. Cut the replacement dust seal band to the dimensions shown in Table 1.
*Length of dust seal band is defined as regulated, but check the length again before mounting for shipping.
- b. Pass the replacement dust seal band through the opening (at 2 places) of the belt separator, and mount on the cylinder body.
- c. Set the bearing in place.
- d. Mount the scraper into the groove on the slide table.

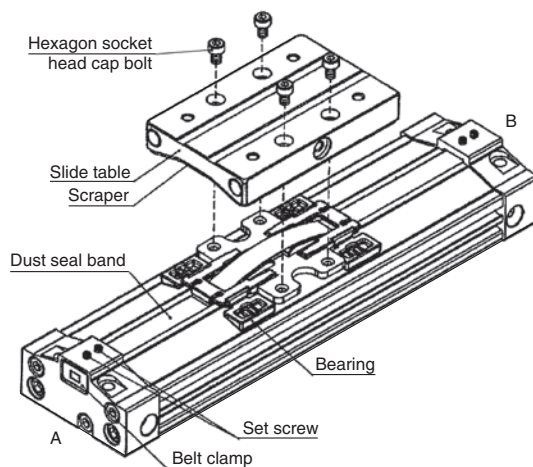

Table 1. Standard length dust seal band

Bore size	MY		MY	
	Part No.	Recommended length	Part No.	Recommended length
ø16	MY3A16-16B-st	st + 106 ⁺⁰ ₋₂	MY3B16-16B-st	st + 118 ⁺⁰ ₋₂
ø20	MY3A20-16B-st	st + 125 ⁺⁰ ₋₂	MY3B20-16B-st	st + 145 ⁺⁰ ₋₂
ø25	MY3A25-16B-st	st + 146 ⁺⁰ ₋₂	MY3B25-16B-st	st + 174 ⁺⁰ ₋₂
ø32	MY3A32-16B-st	st + 189 ⁺⁰ ₋₂	MY3B32-16B-st	st + 221 ⁺⁰ ₋₂
ø40	MY3A40-16B-st	st + 236 ⁺⁰ ₋₂	MY3B40-16B-st	st + 272 ⁺⁰ ₋₂
ø50	MY3A50-16B-st	st + 270 ⁺⁰ ₋₂	MY3B50-16B-st	st + 305 ⁺⁰ ₋₂
ø63	MY3A63-16B-st	st + 316 ⁺⁰ ₋₂	MY3B63-16B-st	st + 352 ⁺⁰ ₋₂

- e. Set the slide table in place referring to the fixing bolt position, and fix it by 4 hexagon socket head bolts.
- f. Align the end surfaces and insert them to the head cover so that the protruded amount of the dust seal band from the cylinder tube will be L dimension shown in Table 2, and fix the set screw closer to the A side holding the belt clamp.
- g. Pull the dust seal band to the B side until it has no protruded part, and fix the set screw close to the B side holding the belt clamp.
- h. Tighten the set screw closer to the cylinder tube on the top of the head cover until all of the lifted part of the dust seal band near the cylinder tube ends at both of A and B sides are eliminated.
In that case, adjust so that Dust seal band located near screws does not lift due to excessive tightening. Proper tightening torque is 0.1 N·m {1 kgf·cm}.
- i. Cycle the slide table at full stroke 2 to 3 times, and check there is no lifted part all over the dust seal band.
- j. Apply grease to the whole sliding part (top of the cylinder tube) of the dust seal band.

Note 1) Handle the dust seal band with care because it is thin and easily bent.

Note 2) Apply grease uniformly as Fig. 4. Use lithium soap grease with consistency No. 1 or No. 2.

Table 2. Dust seal band L dimension (MY3A/B)

Bore size	L dimension (mm)
ø16	11.5
ø20	14
ø25	18
ø32	20.5
ø40	25
ø50	25
ø63	29

1. Disassembly and Maintenance

Pay attention in the following points when the cylinder is disassembled for replacement of piston packing, soft wiper and wearing.

1-1. If the cylinder body or piston is removed from cylinder tube, displace the positions of external slider and piston forcedly to eliminate holding force and take out them individually.

If they are removed together with holding force left, they become unable to separate from each other by internal and external magnet force.

1-2. The used magnet has strong suction force and should be handled with care when external slider and piston slider are removed from cylinder tube.

1-3. Never disassembly the parts which compose the magnet (external slider and piston slider).

The disassembly of them may deprive holding force from the magnet and cause operating failure.

1-4. Take off the watch for handling of external slider and piston slider.

1-5. Handle external slider and piston slider with care to protect the magnet from drop on the floor and collision to the metal.

1-6. And apply the grease periodically on external face of cylinder tube.

Actuators

Modular F.R.L.
Pressure Control Equipment

Air Preparation
Equipment

Industrial Filters

Replacement
Procedure

Actuators

Modular F.R.L.
Pressure Control Equipment

Industrial Filters

1. Disassembly and Maintenance

1-1. If the cylinder needs to be disassembled for replacement of piston packing, soft wiper and wearing, specific tool is required. The specific tool can be ordered by part no. shown on Table.

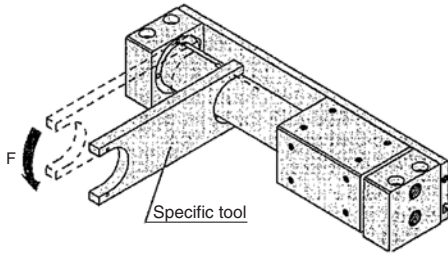

Part no. of specific tool

Part no.	Applicable cylinder tube I.D. (mm)
CYRZ-V	6, 10, 15, 20
CYRZ-W	25, 32, 40
CYRZ-X	50
CYRZ-Y	63

1-2. As for sine rodless cylinders, the cushion ring and seal are assembled to provide the optimum cushioning effect. Therefore, they should be returned to the factory for maintenance. If you disassemble them by necessity, please note the following points.

- a. If the cylinder body or piston is removed from cylinder tube, displace the positions of external slider and piston forcibly to eliminate holding force and take out them individually. If they are removed together with holding force left, they become unable to separate from each other by internal and external magnet force.
- b. Loosen hexagon socket head female on side of end cover by hexagon wrench, take off attachment ring from the end cover with specific tool and then remove the end cover from cylinder tube. After that, remove Circular stop ring mounted on the external face of the cylinder tube by snap ring pliers. The used magnet has strong suction force and should be handled with care when external slider and piston slider are removed from cylinder tube.
- c. Never disassembly the parts which compose the magnet (external slider and piston slider). The disassembly of them may deprive holding force from the magnet and cause operating failure.
- d. When handle magnet assembly, watch on your arm should be put off not to get influence from strong magnetic field.
- e. Handle external slider and piston slider with care to protect the magnet from drop on the floor and collision to the metal.
- f. And apply the grease periodically on external face of cylinder tube. The grease can be ordered by the following part no.
- g. Since the cushion ring is precisely attached to the head cover, be careful not to take it off nor deform/dent it.

1. Maintenance

When this device is disassembled to replace piston packing, wear ring and etc., care should be taken for following points.

- 1-1. To remove the external slider or the piston slider from the cylinder tube, holding force must be released by shifting positions of the external slider and the piston slider forcibly. Removing those without doing so, respective magnets call each other directly and may become impossible to separate.
- 1-2. Upon completing above works to separate respective travel parts, by loosening hexagon head cap screw (at plate A side,) remove cylinder tube and plate A from guide rod A and B. (While replacing works (of packing, so on), other parts should not be disassembled, disassembling other parts may cause to air leakage.)
- 1-3. Magnet assembly (piston slider and external slider) must not be disassembled. Disassembling this may cause to decrease of holding force and other defects.
- 1-4. Piston slider and external slider have a direction (L type and $\phi 6$, $\phi 10$)
The diagram could be referred to. Let external slider (slide lock) and piston slider contact and insert into cylinder tube to form positions shown in the diagram. When posture becomes as (b), turn only piston reverse to insert.
- 1-5. When handle magnet assembly, watch on your arm should be put off not to get influence from strong magnetic field.
- 1-6. Thorough care should be taken for the magnet not to drop on the floor or knock against metal.

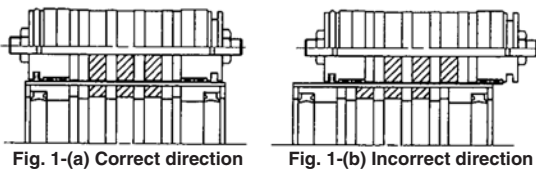

Fig. 1 Direction of the slider

2. Other Precautions

- 2-1. Parts made of iron are used in slider so care should be taken no water drops coming on the cylinder tube.
- 2-2. Grease should be periodically applied to bearing part of slide block.
- 2-3. When it is reassembled, thorough air-flashing to pipings are required not to allow dirt or cutting chips stay in side.
- 2-4. Care should be taken not to make flaw or gouge on external surface of cylinder tube and guide rod. Leaving those flaw or gouge may promote damage of scraper, wear ring and bush and thus cause to malfunction.
- 2-5. Change holding force of magnet (for an example, CY1S25L → CY1S25H) is carried out in our plant. To ask for this, please contact with our sales office.
- 2-6. Expected use under present of water (warmed water), coolant and so on, is advised to consult with us.

1. Maintenance

When this device is disassembled to replace piston packing, wearing and etc., care should be taken for following points.

- 1-1. To remove the external slider or the piston slider from the cylinder tube, holding force must be released by shifting positions of the external slider and the piston slider forcibly.
Removing those without doing so, respective magnets call each other directly and may become impossible to separate.
- 1-2. Upon completing above works to separate respective travel parts, by loosening hexagon head cap screw (at plate A side,) remove cylinder tube and plate A from guide rod A and B. (While replacing works (of packing, so on), other parts should not be disassembled, disassembling other parts may cause air leakage.)
- 1-3. Magnet assembly (piston slider and external slider) must not be disassembled. Disassembling this may cause to decrease of holding force and other defects.
- 1-4. Piston slider and external slider have a direction (L type and $\phi 6$, $\phi 10$). Refer to the fig. 1. Let external slider (slide lock) and piston contact and insert into cylinder tube to form positions shown in the fig. 1. When posture become as (b), turn only piston reverse to insert.



Fig. 1-(a) Correct direction



Fig. 1-(b) Incorrect direction

Fig. 1 Direction of the slider

- 1-5. When handle magnet assembly, watch on your arm should be put off (particularly analog one) not to get influence from strong magnetic field.
- 1-6. Through care should be taken for the magnet not to drop on the floor or knock against metal.

2. Other Precautions

- 2-1. Parts made of iron are used in slider so care should be taken no water drops coming on the cylinder tube.
- 2-2. Grease should be periodically applied to bearing part of slide block.
- 2-3. When it is installed, through air-flashing to pipings are required not to allow contaminations or chips stay inside.
- 2-4. Care should be taken not to make flaw or gouge on external surface of cylinder tube and guide rod. Leaving those flaw or gouge may promote damage of scraper, wear ring and bush and thus cause to malfunction.
- 2-5. Change holding force of magnet (for example, CY1L25L \rightarrow CY1L25H) is carried out in our plant. To ask for this, please contact with our sales office.
- 2-6. Expected use under present of water (warmed water), coolant and so on, is advised to consult with us.

⚠ Caution

1. The cross roller part which is the guide system of the Air slide table, should not be taken apart because the pre-load has been already adjusted at the mounting stage.
2. Replenishment of grease during piston packing replacement.
Apply special grease to the piston packing section and the sliding section.
(Grease No.: GR-L)

1. Replacement Procedure of Piston Seal

- 1-1. Remove hexagon socket head cap screws which connect end plate and table.
- 1-2. Remove end plate.

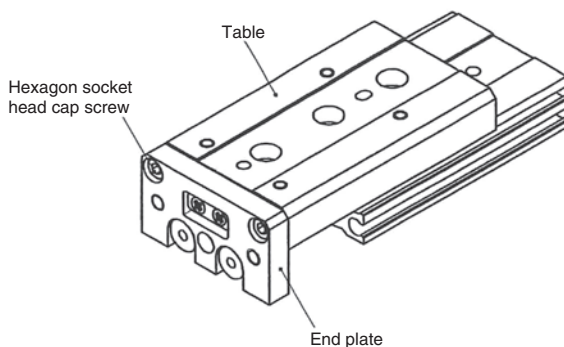

Series MXQ

Cautions after removing the end plate

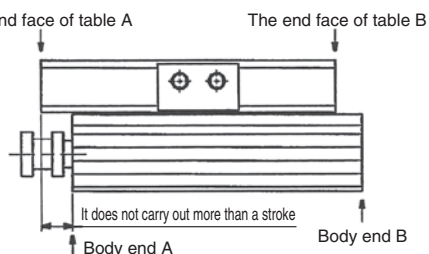

Make sure that table end A does not exceed the body end A at the full stroke after removing the end plate. Make sure that table end B does not exceed the body end B at the full stroke after removing the end plate. (The steel balls in the guide will fall out.)

- 1-3. Remove the C shaped retaining ring.
(Using a retaining ring tool)
- 1-4. Pull out piston assembly.

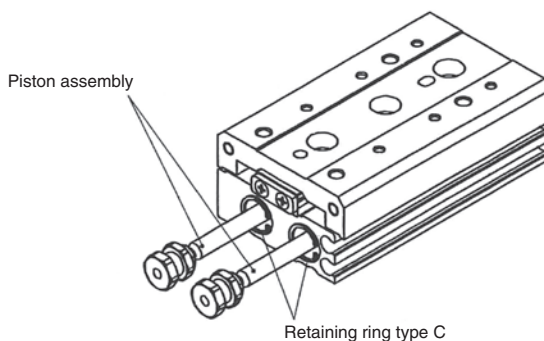

Actuators

Modular F.R.L.
Pressure Control Equipment

Air Preparation
Equipment

Industrial Filters

Replacement
Procedure

Actuators

Modular F.R.L.
Pressure Control Equipment

Industrial Filters

Series **MXS/MXQ/MXQR** Replacement Procedure of Seal 2

- 1-5. Apply grease to the piston seal and replace it.
- 1-6. Remove the C shaped retaining ring on the head cap side. (Use a tool for the C shaped retaining ring.)
- 1-7. Remove the head cap, apply grease and replace the O-ring.

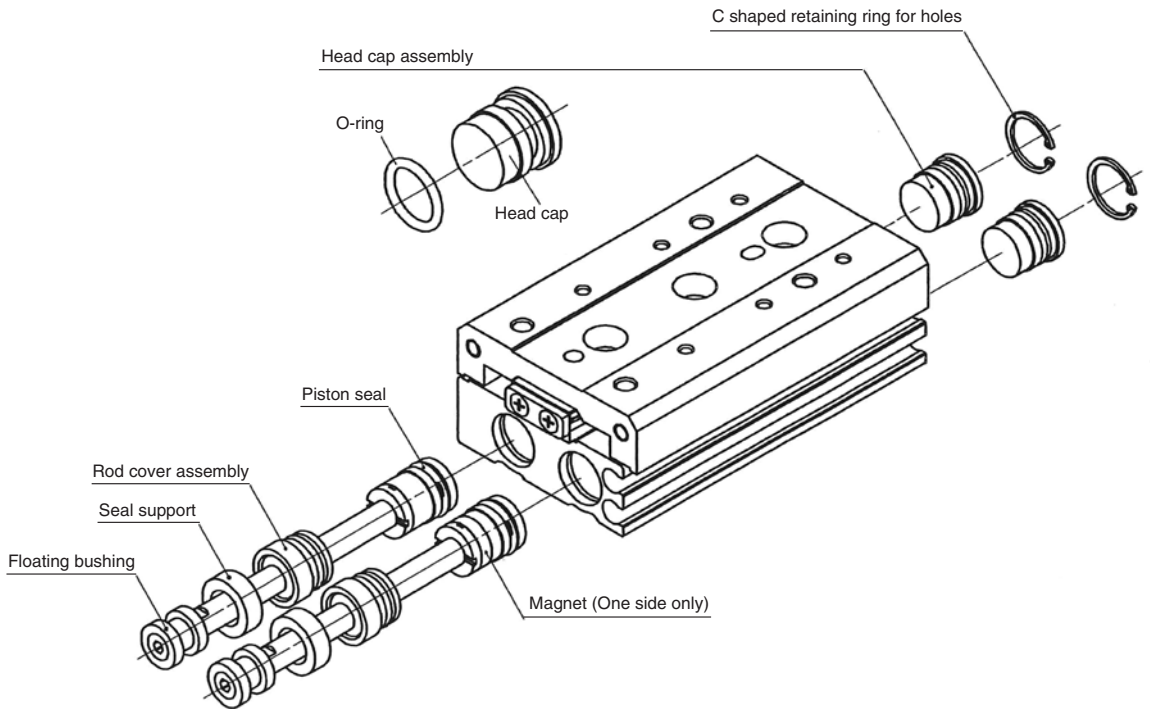

1-8. Remove the floating bushing.

ø6 and ø8 do not have width across flats. Lock onto the shaded part with Round nose chain pliers with side cutters. (It is not possible to lock onto areas other than the shaded part.)

In the case of ø12 to ø25, fix the width across flats of the rod with a wrench.

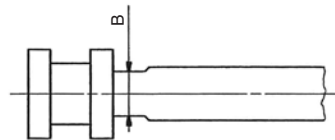
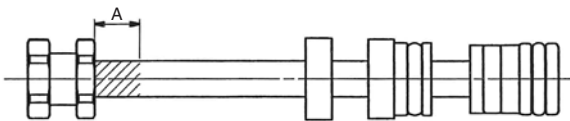

	MXS6	MXS8
Dimension A	3.2 mm or less	3.6 mm or less

	MXS12	MXS16	MXS20	MXS25
Dimension B	5 mm	6 mm	8 mm	10 mm

	MXQ6	MXQ8
Dimension A	3.2 mm or less	3.6 mm or less

	MXQ12	MXQ16	MXQ20	MXQ25
Dimension B	5 mm	6 mm	8 mm	10 mm

Series MXS/MXQ/MXQR Replacement Procedure of Seal 3

- 1-9. Remove the seal support.
- 1-10. Remove the rod cover assembly.
- 1-11. Apply grease to the O-ring and replace it.
- 1-12. Apply grease to the rod seal and replace.

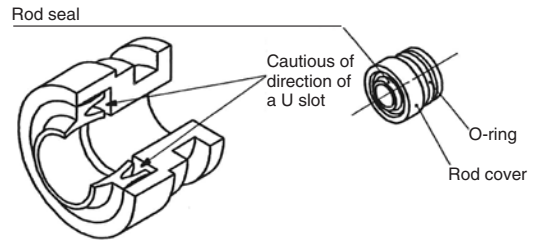

- 1-13. Mount the rod cover assembly and seal support to the piston rod assembly and insert it into the body.
- 1-14. Fix the seal support with the C shaped retaining ring. (Use a tool for retaining ring.)
- 1-15. Insert the head cap assembly into the body and fix it with the C shaped retaining ring. (Use a tool for retaining ring.)

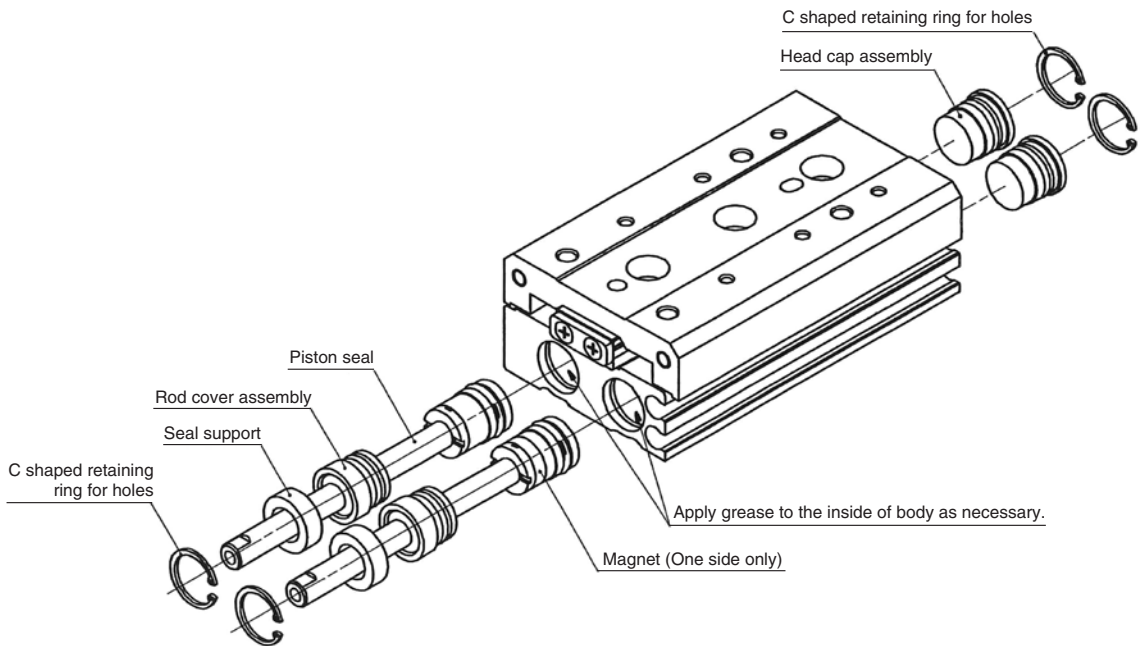

Actuators

Modular F.R.L.
Pressure Control Equipment

Air Preparation
Equipment

Industrial Filters

Replacement
Procedure

Actuators

Modular F.R.L.
Pressure Control Equipment

Industrial Filters

Series **MXS/MXQ/MXQR** Replacement Procedure of Seal 4

1-16. Mount the floating bushing onto the piston rod assembly.

ø6, ø8

Lock onto the shaded part.
Part other than shaded part cannot be caught.

Model	Dimension A
MXS6	3.2 mm or less
MXS8	3.6 mm or less

Model	Dimension A
MXQ6	3.2 mm or less
MXQ8	3.6 mm or less

Floating bushing

Model	Tightening torque (N·m)
MXS6	0.21
MXS8	0.41

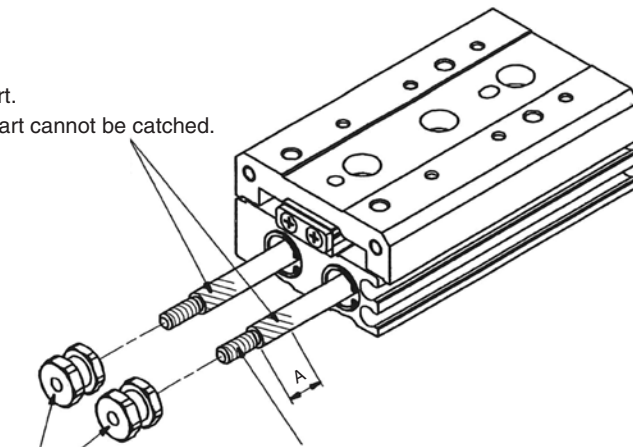

Apply Henkel Japan Loctite No.262 or an equivalent adhesive.
If adhesive is squeezed out from part A after assembly, wipe it off.

Model	Tightening torque (N·m)
MXQ6	0.21
MXQ8	0.41

ø12 to ø25

Hexagon socket countersunk head screw

Model	Hexagon socket head cap screw Fe Ni	Tightening torque (N·m)
MXS12	M3 x 14	1.0
MXS16	M4 x 18	2.4
MXS20	M5 x 20	4.3
MXS25	M6 x 25	6.9

Model	Hexagon socket head cap screw Fe Ni	Tightening torque (N·m)
MXQ12	M3 x 14	1.0
MXQ16	M4 x 18	2.4
MXQ20	M5 x 20	4.3
MXQ25	M6 x 25	6.9

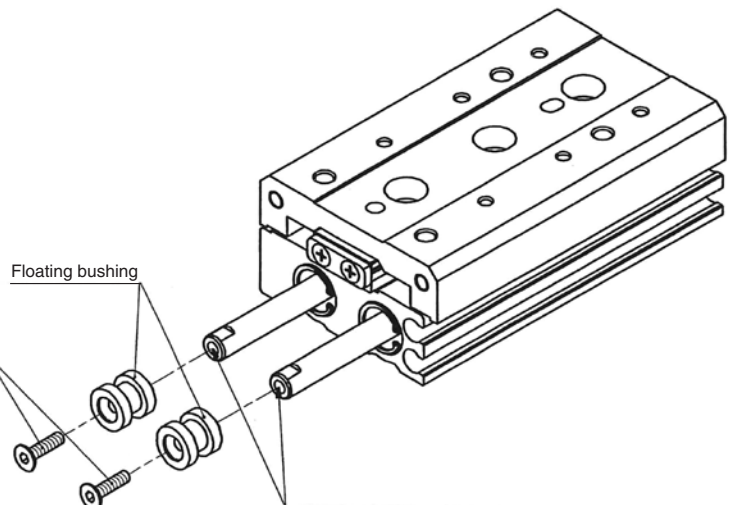

Apply Henkel Japan Loctite No.262 or an equivalent adhesive.

Series **MXS/MXQ/MXQR** Replacement Procedure of Seal 5

1-17. Mount the end plate.

1-18. Tighten the end plate mounting bolt with the specified torque.

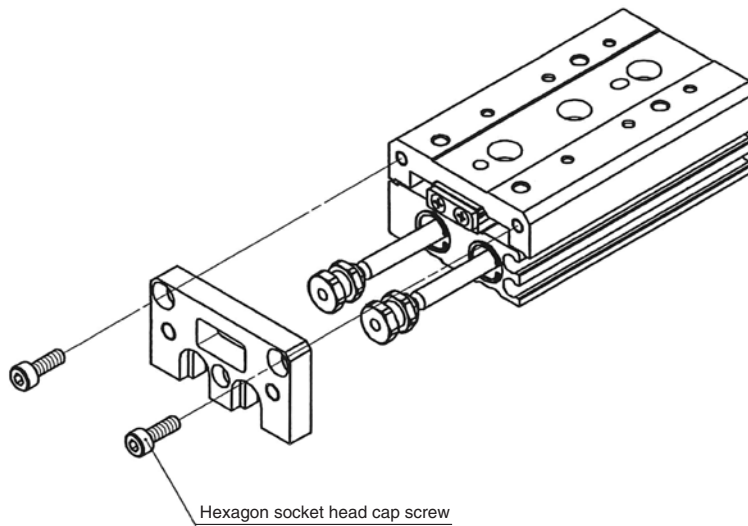

Apply Henkel Japan Loctite No.262 or an equivalent adhesive.

Model	Hexagon socket head cap screw Fe Ni	Tightening torque (N·m)
MXS6	M2.5 x 6	0.5
MXS8	M3 x 6	0.9
MXS12	M4 x 10	2.1
MXS16	M5 x 12	4.3
MXS20	M5 x 14	
MXS25	M6 x 18	6.9

Model	Hexagon socket head cap screw Fe Ni	Tightening torque (N·m)
MXQ6	M2.5 x 6	0.5
MXQ8	M3 x 6	0.9
MXQ12	M4 x 8	2.1
MXQ16	M5 x 10	4.3
MXQ20	M5 x 16	
MXQ25	M6 x 16	6.9

A level difference is set to t

No level difference with a table

Model	Level difference t mm	Model	Level difference t mm
MXS6	0.5	MXQ6	0.3
MXS8			
MXS12			
MXS16	0.3	MXQ12	0.5
MXS20	0.5	MXQ20	
MXS25		MXQ25	

Actuators

Modular F.R.L.
Pressure Control Equipment

Air Preparation
Equipment

Industrial Filters

Replacement
Procedure

Actuators

Modular F.R.L.
Pressure Control Equipment

Industrial Filters

Series *MXF* Replacement Procedure of Seal 1

⚠ Caution

The cross roller section which is the guide system of the air slide table should not be disassembled because the pre-load has been already adjusted at mounting.

1. Replacement Procedure of Piston Seal

1-1. Loosen the hexagon socket head cap screws which connect the end plate to the table.

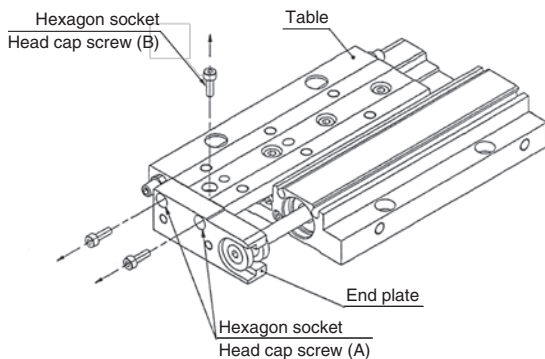

End plate attachment (A)

Model	Hexagon socket head cap screw	Tightening torque (N·m)
MXF8	M2 x 10	0.25
MXF12	M2.5 x 10	0.47
MXF16	M3 x 10	0.88
MXF20	M4 x 14	2.06

Loctite No. 242 of Henkel Japan Ltd. or its equivalent is applied.

End plate attachment (B)

Model	Hexagon socket head cap screw	Tightening torque (N·m)
MXF8	M2 x 8	0.25
MXF12	M2.5 x 8	0.47
MXF16	M3 x 10	0.88
MXF20	M4 x 14	2.06

Loctite No. 242 of Henkel Japan Ltd. or its equivalent is applied.

1-2. Move the end plate as indicated by the arrow to remove.

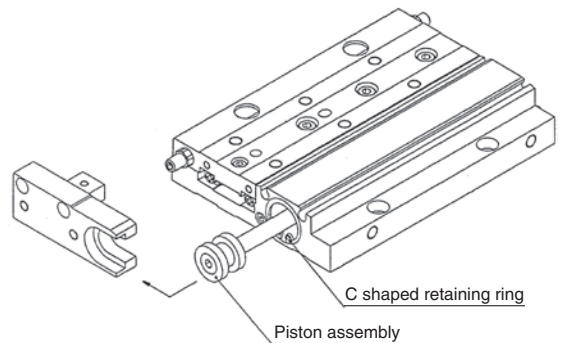

1-3. Take off the C shaped retaining ring with a tool for retaining ring.

1-4. Pull out the piston assembly.

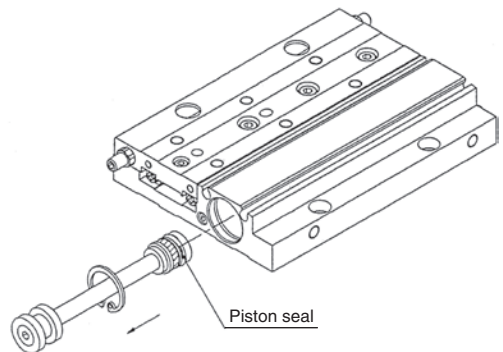

1-5. Change the piston seal.

1-6. Apply grease to the piston and the rod.

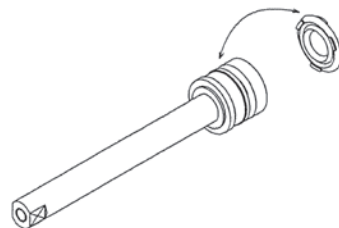

1-7. Put the piston rod, and assemble in the reverse order.

Series **MXW** Replacement Procedure of Seal 1

Caution

The linear guide section which is the guide system of the air slide table should not be disassembled because the pre-load has been already adjusted at mounting.

1. Replacement Procedure of Piston Seal

- 1-1. Remove end plate mounting bolts.
- 1-2. Remove C shaped retaining rings for end caps and head caps at first, and remove the both caps.
- 1-3. Hold the rod with a spanner, and remove the floating bushing mounting bolt.
- 1-4. Remove the end plate.

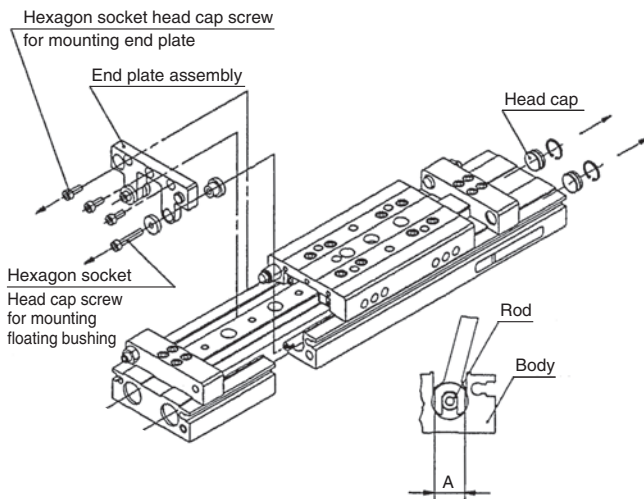

Note) The floating bushing should be mounted/dismounted carefully with a spanner whose width is A to avoid flaws inside the body.

- 1-5. Push out the piston rod with a driver less than ϕB .

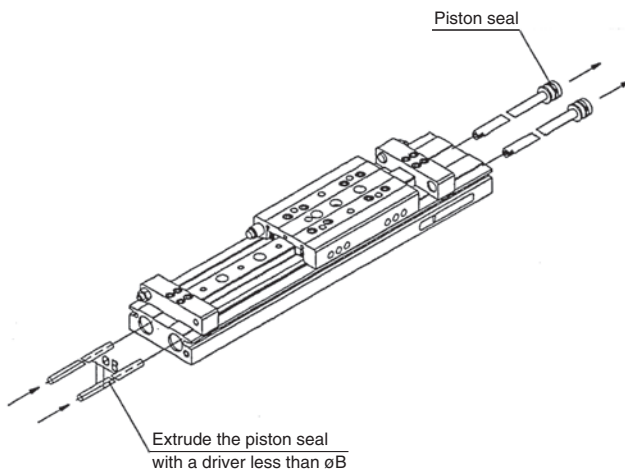

	MXW8	MXW12	MXW16	MXW20	MXW25
ϕB	3	5	7	9	11

End plate attachment

Model	Hexagon socket head cap screw	Tightening torque (N·m)
MXW8	M3 x 8	0.6
MXW12	M3 x 8	0.6
MXW16	M4 x 12	2.4
MXW20	M5 x 12	2.8
MXW25	M6 x 16	8.6

Loctite No. 242 of Henkel Japan Ltd. or its equivalent is applied.

Floating bushing attachment

Model	Hexagon socket head cap screw	Tightening torque (N·m)
MXW8	M3 x 8	0.6
MXW12	M3 x 14	1.0
MXW16	M4 x 20	2.4
MXW20	M5 x 20	5.1
MXW25	M6 x 30	8.6

Loctite No. 262 of Henkel Japan Ltd. or its equivalent is applied.

	MXW8	MXW12	MXW16	MXW20	MXW25
Dimension A	8	8.5	14.5	18	23.5
Width across flat	3.5	5	6	8	10

- 1-6. Change the piston seal.
- 1-7. Apply grease to the piston and the rod.
- 1-8. Put the piston rod, and assemble in the reverse order.

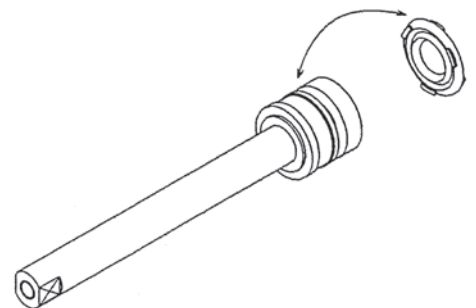

Series *MXP* Replacement Procedure of Seal 1

1. Replacement Procedure of Piston Seal

MXPJ6

- 1-1. Remove the C shaped retaining ring. (Using a retaining ring tool)
- 1-2. Remove the end cap.
- 1-3. Remove the piston.

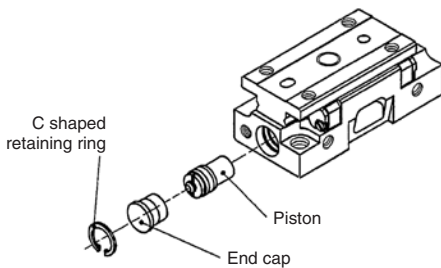

- 1-4. Apply grease to piston for replacement.



- 1-5. Apply grease to O-ring for replacement.



- 1-6. Apply grease to the piston surface.

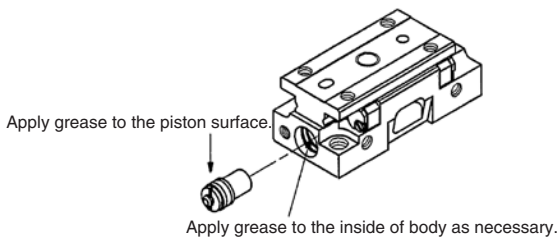

- 1-7. Insert piston and assemble parts in the reverse order of removal.

MXP6

- 1-1. Remove bolts for end plate mount.
- 1-2. Remove end plate.
- 1-3. Remove O-ring on the end plate.

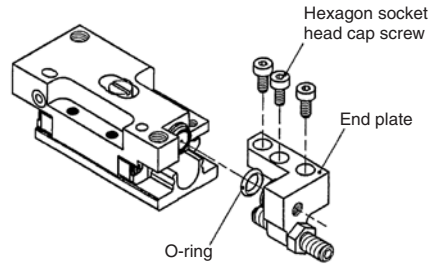

- 1-4. Remove the C shaped retaining ring. (Using a snap ring tool)
- 1-5. Remove end cap.
- 1-6. Remove piston.

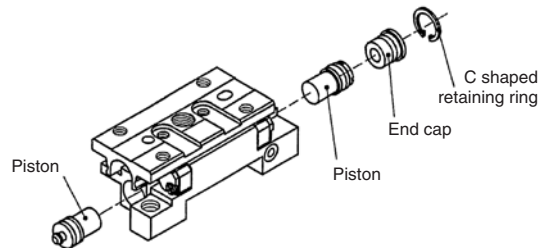

- 1-7. Apply grease to piston for replacement.

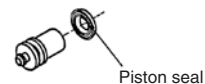

- 1-8. Apply grease to O-ring for replacement.

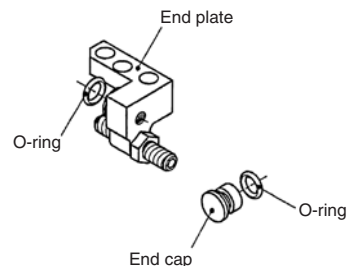

Series MXP Replacement Procedure of Seal 2

1-9. Apply grease to the piston surface.

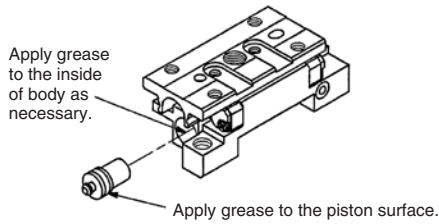

1-10. Insert the piston, and assembly in the reverse order.

Note) Tighten the end plate mounting bolt with the specified torque.

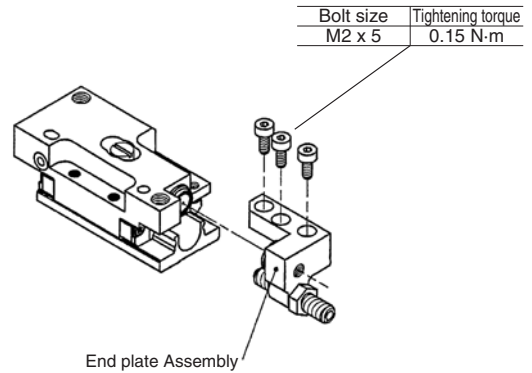

No gap is present at the mating surface between the body assemblies.

MXP8, 10, 12, 16

1. Remove bolts for end plate mount.
2. Remove end plate.
3. Remove the tube and O-ring.
4. Apply grease to the O-ring and replace it.
5. Remove the joint shaft. Remove the piston assembly from the body.
6. Apply grease to the piston seal and replace it.

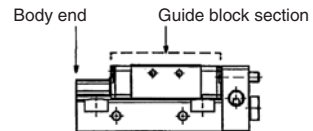

Make sure that the guide block will not exceed the body end surface after removing the joint shaft. (The steel balls in the guide will fall out.)

Type	Width across flates
MXP8	
MXP10	2.5 mm
MXP12	
MXP16	3 mm

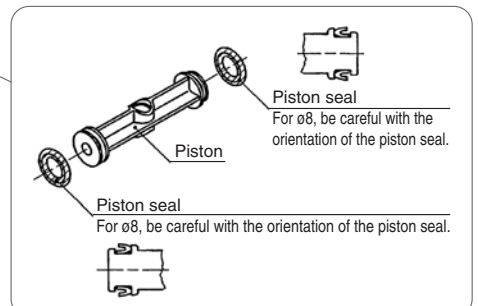
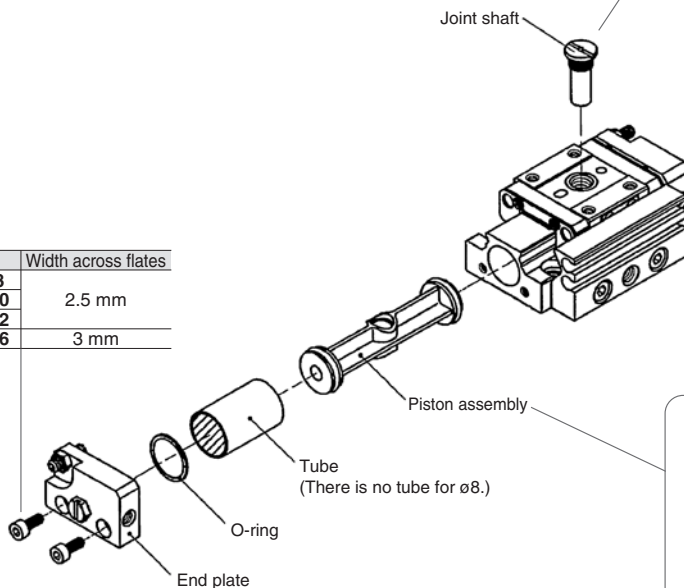

Series MXP Replacement Procedure of Seal 3

7. Insert the piston assembly to the body, and tighten the body with the joint shaft.
8. Apply grease to the shaded part of the tube inner surface if necessary. (See the drawing of previous page)
9. Mount the tube and O-ring.
10. Mount end plate.
11. Fasten bolts for end plate mount with specified torque.

Note 1) Assemble end plate so that A, B dimensions will be values on table below.

(mm)		
Type	A	B
MXP8	0.2	0.2
MXP10		
MXP12	0.5	0.3
MXP16		

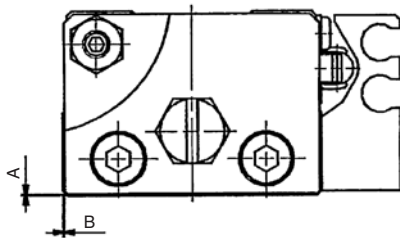

Type	Tightening torque joint shaft
MXP8	0.4 N·m
MXP10	0.7 N·m
MXP12	1.8 N·m
MXP16	3.6 N·m

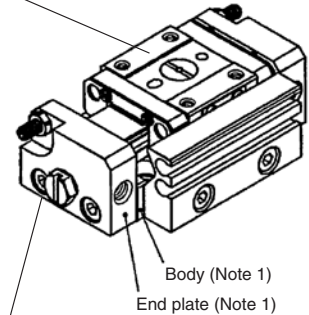

Type	Bolt torque
MXP8	0.45 N·m
MXP10	0.6 N·m
MXP12	
MXP16	1.4 N·m

12. Remove the end plate mounting bolt on the opposite side.
13. Remove the end plate on the opposite side.
14. Remove the tube and O-ring.
15. Apply grease to the O-ring and replace it.
16. Apply grease to the shaded part of the tube inner surface if necessary.
17. Mount the tube and O-ring.
18. Mount the end plate on the opposite side. (*2)
19. Tighten the end plate mounting bolt on the opposite side with the specified torque.

Note 2) Assemble end plate so that A, B dimensions will be values on table below. (As well as *1)

(mm)		
Type	A	B
MXP8	0.2	0.2
MXP10		
MXP12	0.5	0.3
MXP16		

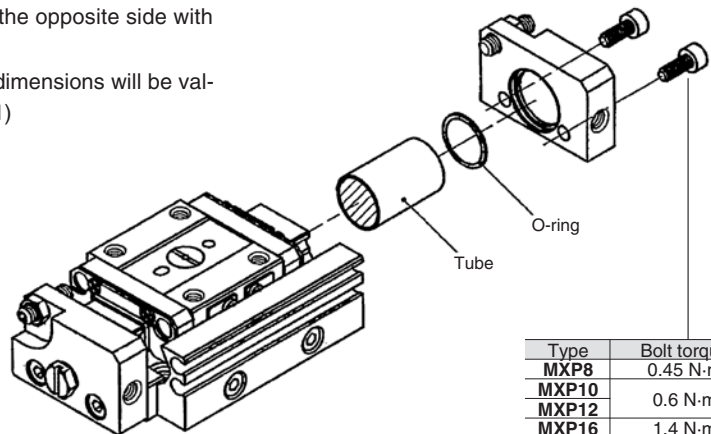
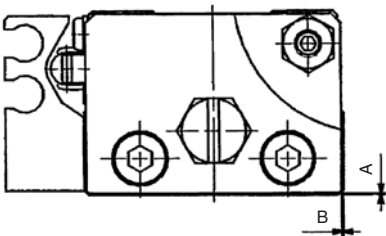

Type	Bolt torque
MXP8	0.45 N·m
MXP10	0.6 N·m
MXP12	
MXP16	1.4 N·m

Series *MX* Replacement Procedure of Seal ①

1. Disassembly Procedure (Seal and Wearing)

1-1. a. Remove guide block fixing studs.

Note) Take care so that guide block would not come off even partially to prevent steel ball of guide block from coming out and becoming unavailable.

- b. Loosen switch rail fixing studs and disconnect switch rail.
- c. Loosen end plate fixing hexagon socket head cap screws and disconnect end plate.
- d. Disconnect cylinder assembly.

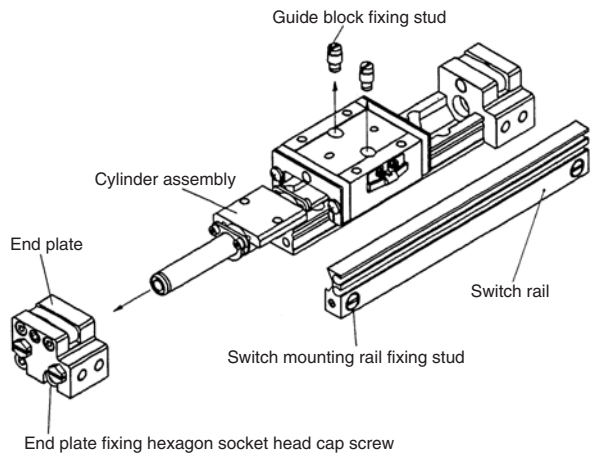

1-2. a. Take off end cap from tube of cylinder assembly.

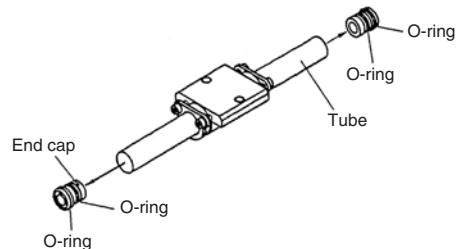

1-3. a. Insert round bar jig into tube and hold piston slider.

Note) Do not damage internal face of tube at this time.

- b. Move external slider forcedly to make holding force unable to act.
- c. Take off piston slider from tube.
- d. Take off external slider from tube.

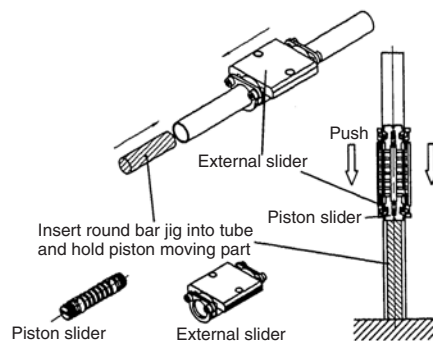

1-4. a. Loosen hexagon socket head bolts on both end faces of body and disconnect spacer.

Note) Take care so that magnet B and yoke B would not come out.

- b. Take off wearing B and cylinder scraper from spacer and replace each with new one.

Note) Mind mounting direction of cylinder scraper.

- c. Tighten hexagon socket head cap screws on right end face with referential mark on body turned front until spacer is made close to body tightly.
- d. Tighten hexagon socket head cap screws on left end face with referential mark on body turned front until spacer is mounted on body with clearance.

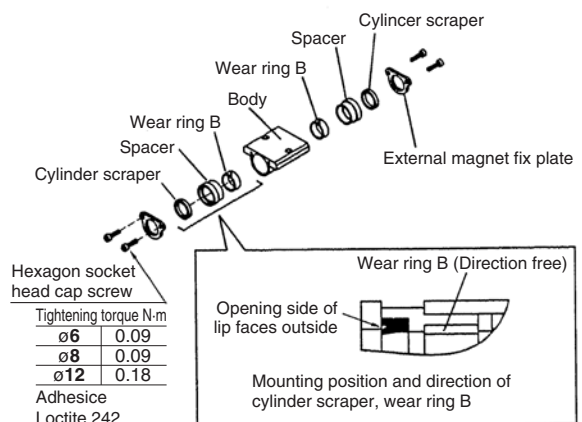

Series *MX* Replacement Procedure of Seal 2

Note) Tighten each two hexagon socket head cap screws by turn gradually until specified torque is reached to make force given to them even.

Note) Before tightening, apply specified adhesive (Loctite 242 or equivalent) on hexagon socket head cap screws.

- 1-5. a. Holding one piston by flat blade screw driver, loose the other piston by flat blade screw driver.
- b. Take off yoke A and magnet A from shaft. Magnet A should be kept with stick inserted.
- Note) Mounting direction of magnet A is specified. So, keep them in the manner like above not to be unable to recognize correct mounting direction.
- c. Take off wearing A and piston seal and replace each with new one.
- Note) Mind mounting direction of piston seal in MX6 and MX8.
- Note) Apply specified grease (Grease pack: GR-S-* or equivalent) on wearing A and piston seal.
- Note) Confirm piston seal is mounted without twist.
- Note) Piston seal is mounted only on one side in MX12.
- d. Insert yoke A and magnet A into shaft the reverse procedure.
- e. Tighten piston to shaft by torque specified on right figure.
- Note) Apply specified adhesive (Loctite 262 or equivalent) on the end of shaft.

Caution on mounting external slider

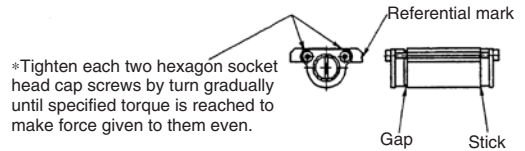

Tighten the bolt with comes right when referential mark is turned front. (Gap is created between left spacer and body.)

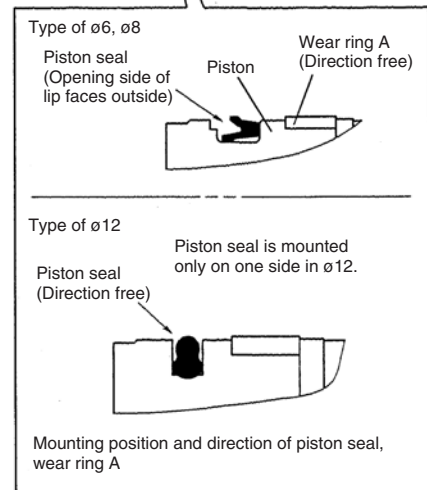
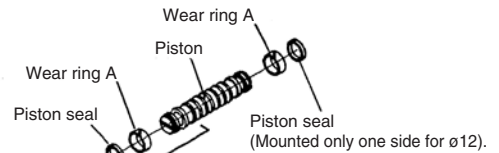

Tightening torque N·m	
ø6	0.09
ø8	0.09
ø12	0.18

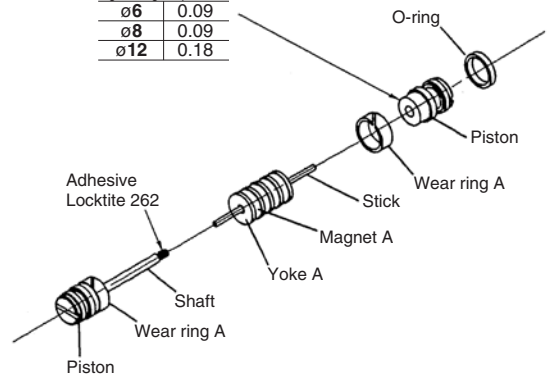

How to remove Yoke A and Magnet A

Series MXY Replacement Procedure of Seal 3

- 1-6. a. Apply grease all around piston slider.
- b. Apply grease all around internal face of external slider.
- c. Insert piston moving part and external slider into tube.
- d. Move external moving part to a little over stroke end manually to engage it with piston slider (i. e. to locate magnet coupling on adequate position.)
- e. Apply grease evenly on internal and external face of tube.

Note) Do not close external slider to the end of tube to apply the grease because all of grease is brought to there during operation.

Note) Use specified one (Grease pack: GR-S* or equivalent) for grease.

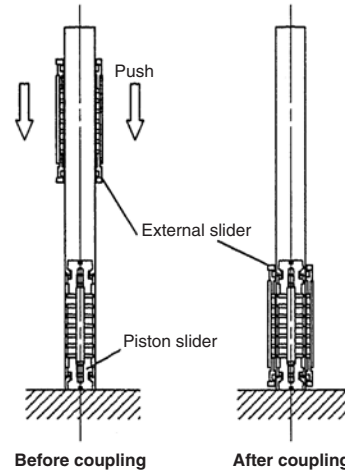

Caution on applying grease on tube

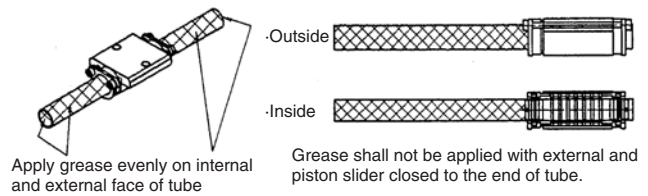

- 1-7. Put end cap in tube.

Note) Ensure O-ring doesn't come off.

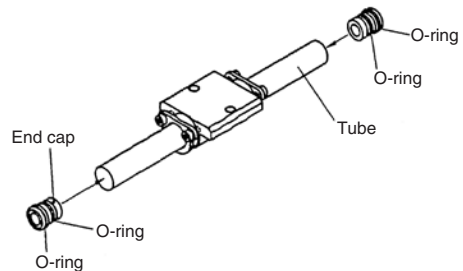

Actuators

Modular F.R.L.
Pressure Control Equipment

Air Preparation
Equipment

Industrial Filters

Replacement
Procedure

Actuators

Modular F.R.L.
Pressure Control Equipment

Industrial Filters

Series MXY Replacement Procedure of Seal 4

1-8. a. Tighten end plate on left side to rail temporarily with referential mark on guide block turned to front (with port bore turned to front as well).

Note) Apply specified adhesive (Loctite 242 or equivalent) on end plate holding hexagon socket head cap screws.

b. Pass cylinder assembly between rail and guide block with referential mark on cylinder assembly turned to front and then tighten end plate on right side temporarily like one on left side.

c. Tighten guide block holding stud by torque specified on right figure to hold guide block to external slider.

Note) Apply specified grease (Grease pack: GR-S-* or equivalent) on the side of guide block fixing stud except for threaded part.

d. Tighten end plate fixing hexagon socket head cap screw by torque specified on right figure.

e. Tighten switch rail holding stud by torque specified on right figure to hold switch rail to end plate.

Note) Keep step among end plate, switch rail and rail within the value shown on right figure.

Note) Ensure switch rail doesn't contact magnet by moving guide block all over its movable part.

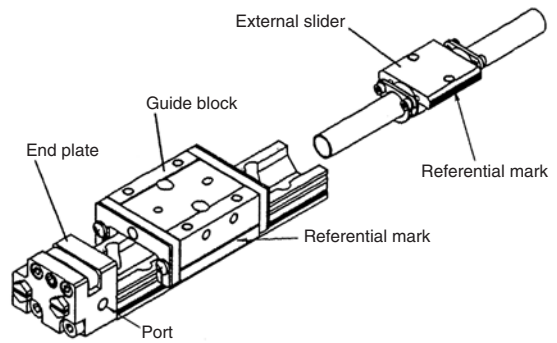

Guide block fixing stud

Tightening torque N-m	
φ6	0.32
φ8	0.76
φ12	2.6

Adhesive
Loctite 242

End plate fixing hexagon socket head bolt

Tightening torque N-m	
φ6	0.63
φ8	1.5
φ12	3

Adhesive
Loctite 242

Switch rail fixing stud
Tightening torque
0.7 N-m

Step between end plate and rail shall comply with table.

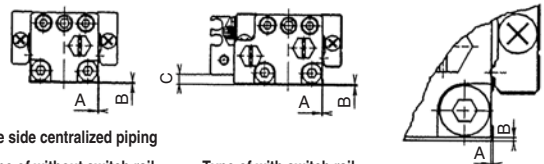

One side centralized piping

Type of without switch rail

Type of with switch rail

Detail of dimension A and B

Model	A	B	C
MXV6	0.3	0.3	0.5
MXV8	0.3	0.5	3.5
MXV12	0.3	0.5	8.5

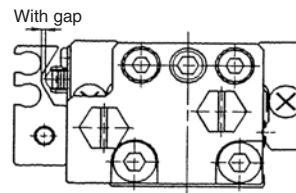

⚠ Caution

Cylinder needs to be disassembled/assembled at clean environment. Use a clean cloth.
Before disassembly, eliminate the dirt on the outer surface so that foreign material does not enter the cylinder or the guide.

1. Disassembly

1-1. Tools

Retaining ring plier for hole, hexagon wrench, spanner, socket wrench (or air impact wrench).

1-2. Fix the piston rod so that it is not scratched. Remove the guide rod assembly by loosening the plate mounting bolt with a hexagon wrench or socket wrench.

Or, loosen the plate set bolt with the air impact wrench to remove the guide rod assembly.

Continue the work without removing the guide rod from the plate.

1-3. Remove the two retaining rings (rod and head side) with the retaining ring pliers, and pull out the collar, head cover and piston rod assembly.

For air cushion type and end lock type, it is necessary to remove the collar and parts below.

Air cushion type (ø80, ø100)

- Set screw at the bottom of the cylinder.

End lock type

- End lock unit (See below)

Bore size (mm)	Retaining ring size	Width across flat (mm)	Plate mount bolt tightening torque (kgf·cm)
12	RTW-13	5	14
16	RTW-18	6	34
20	RTW-22	8	52
25	RTW-26	10	88
32	RTW-34	14	220
40	RTW-42	14	220
50	RTW-52	17	440
63	RTW-65	17	440
80	RTW-82	22	1,240
100	RTW-102	27	2,000

Removal of End Lock (With End Lock)

1. Tools

Retaining ring plier for hole, hexagon wrench, spanner, socket wrench (or air impact wrench), watchmakers screw driver.

2. Insert the manual bolt from the top of the end lock unit rubber cap, and screw the bolt into the lock piston, (Not necessary for -*L, lock tyoe)

3. Remove two hexagon socket head cap screws to pull out the end lock unit.

4. For ø20 to ø63, remove the lock piston seal.

For ø80, ø100, remove the packing seal retainer and locking piston seal.

5. Remove the lock holder mounting bolt to remove the lock unit and gasket.

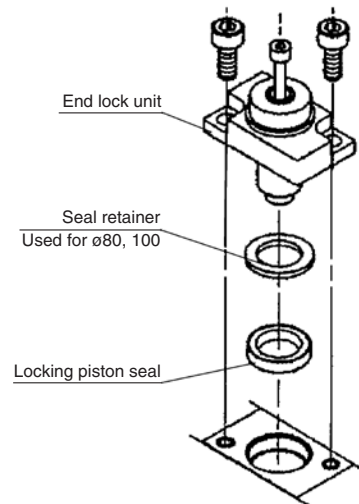

Fig. 1 How to remove the end lock

2. Removal of the Seal

2-1. Rod seal

a. Tools

Watchmakers screw driver, etc.

b. Insert the driver to the collar front to pull out the seal like Fig. 2.

Do not damage the seal groove on the collar at this time.

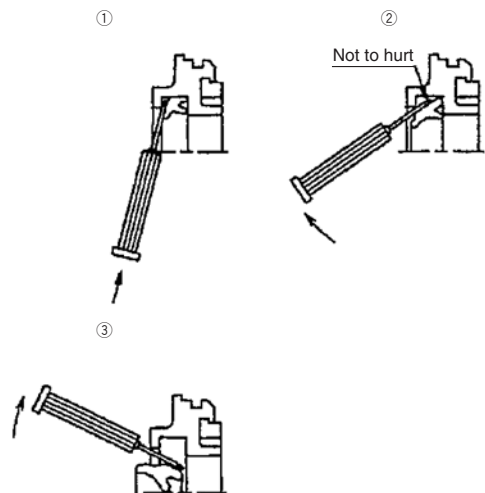

Fig. 2 How to remove rod seal

Actuators

Modular F.R.L.
Pressure Control Equipment

Air Preparation
Equipment

Industrial Filters

Replacement
Procedure

Actuators

Modular F.R.L.
Pressure Control Equipment

Industrial Filters

2-2. Piston seal

Wipe off grease around piston seal first to make removal easier.

Hold piston seal with one hand and push it into groove so that piston seal can be lifted off and pulled out without using a watchmakers screw driver. (Fig. 3)

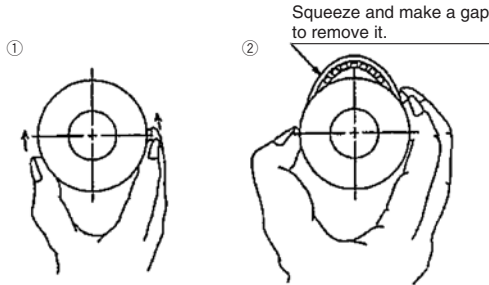

Fig. 3 How to remove piston seal

2-3. Gasket

Pull out the collar and the head cover outer rim or the gasket inside of the body ($\phi 32$ or larger) with precision driver.

2-4. Cushion seal (With air cushion only)

- a. Tool: Watchmakers screw driver, etc.
- b. As shown in Fig.4, pull out the cushion seal by inserting the precision screwdriver from the back of the seal and the head cover. Take care not to damage the seal groove at this time.

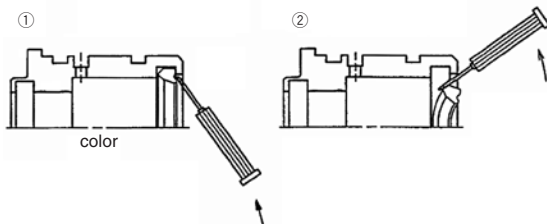

Fig. 4 Removing the cushion seal

3. Application of Grease

Use grease pack in table or lithium soap base grease JIS2, or equivalent.

Table Grease pack no.

10 g type	GR-S-010
20 g type	GR-S-020

3-1. Rod seal

Apply grease slightly to outer circumference of new seal for replace. This helps the seal to accustom to the collar. For the groove, fill it with grease. This is necessary for operation.

Outer circumference grease



Fig. 4

3-2. Piston seal

Apply grease to outer/inner circumference of seal slightly and evenly to make mounting this to the piston easier.

3-3. Gasket

Apply grease slightly. Provide better sealing and stop falling.

3-4. Cushion seal (With air cushion only)

Apply grease to outer/inner circumference of seal slightly and evenly to make mounting this to the seal groove.

3-5. Cylinder parts

Apply grease to cylinder parts including the guide.

With end Lock

Use lithium soap radical grease JIS2 corresponding to such as "Nippon Oil Corporation multipurpose grease No. 2", "Idemitsu Daphne coronex No. 2", "Kyoseki lisonix grease No. 2".

4. Assembly

4-1. Mount seal

a. Rod seal

Mind the seal direction. Apply grease all over the seal and inner surface of the bush as Fig. 8. You may use a precision screw driver to apply grease when small bore diameter.

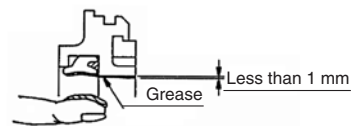

Fig. 8 Rod seal

b. Piston seal

Apply grease rubbing to seal groove and outer circumference.



Fig. 9 Piston seal

c. Gasket (With rubber bumper)

Mount to the groove of the collar and the head cover. For $\phi 32$ or larger, mount to the inner groove of the body, not to the head cover.

This case, the gasket of the body is large type.

d. Gasket (With air cushion)

Mount to the groove of the collar and the head cover. For $\phi 32$ or larger, mount to the inner groove of the head cover and the body.

This case, the gasket of the body is large type.

Do not mount the gasket on the air passage (through hole groove) as in Fig.10.

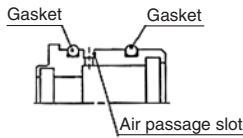

Fig. 10 Gasket mounting position

e. Cushion seal (With air cushion only)

Mount the seal in the correct direction. Apply grease thinly and evenly to the inner circumference of the seal. As the seal has a floating mechanism, it is normal to have some play.

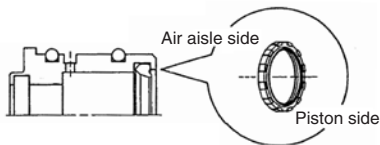

Fig. 11 Cushion seal mounting position

4-2. Assemble cylinder

a. Insert the head cover to the body to fix with a retaining ring.

b. Insert the collar to the piston rod.

Apply grease to the piston rod end or 30 degree of slope at the end of spanner flat, and insert the collar gently so that the piston seal is not hurt.

c. Insert the piston and the collar to the tube and fix it with a retaining ring.

Apply grease to the inlet of the tube and insert the piston and the collar gently so that the piston seal and the gasket are not hurt by the retaining ring groove.

d. Guide rod assembly assembling

Apply glue to the plate mounting bolt when mounting the guide rod assembly. Then tighten the bolt with tightening torque in table 1.

After assembling, ensure manually that work properly operate smoothly.

Check the air leakage.

With End Lock

1. Mount end lock

Apply grease to the lock piston surface, lock holder inner surface to insert the gasket and lock holder. Then, fix them with new hexagon socket head cap screws included in accessories.

Insert the end lock unit and fix it with new hexagon socket head cap screws included in accessories. (See drawing 12, 13, 14, 15)

After assembling, ensure manually that end lock work properly and cylinder operate smoothly with lock released.

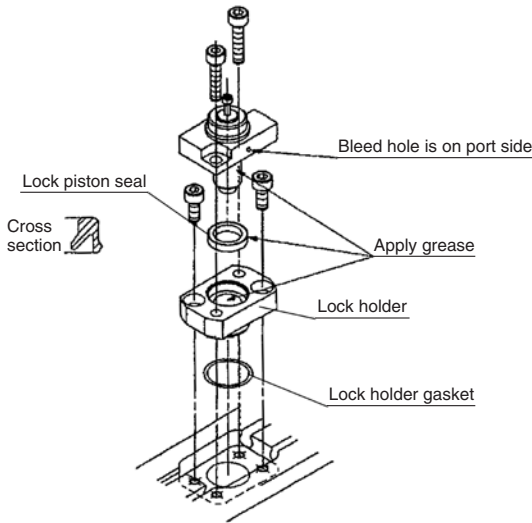

Fig. 12 End lock reassembled ($\phi 20, \phi 25$)

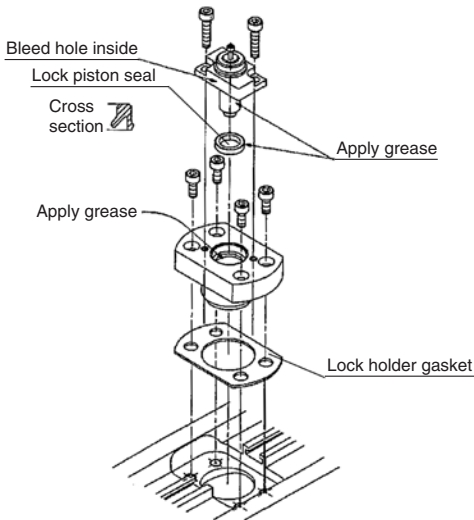

Fig. 14 End lock reassembled ($\phi 50, \phi 63$)

Cap and lock holder bolt tightening torque

Hexagonal bolt	Bore size (mm)	Tightening torque (N)
M3	$\phi 20$ to $\phi 63$	0.71 to 0.86
M5	$\phi 80, \phi 100$	2.65 to 3.24

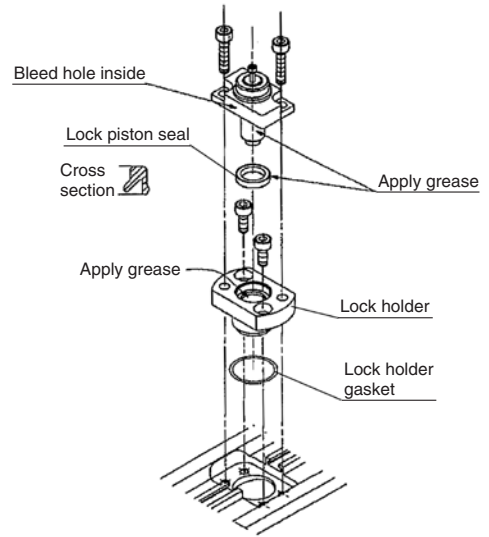

Fig. 13 End lock reassembled ($\phi 21, \phi 40$)

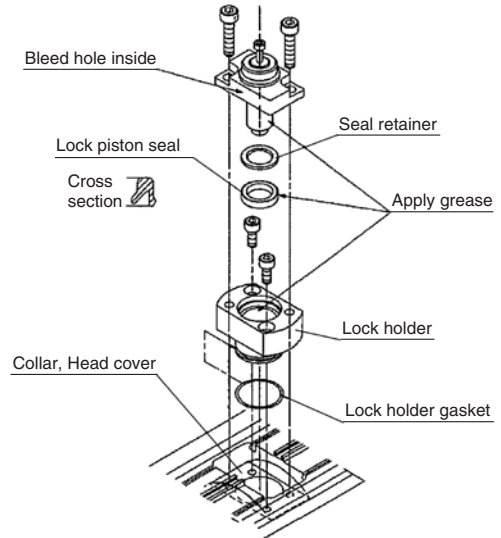

Fig. 15 End lock reassembled ($\phi 80, \phi 100$)

⚠ Caution

Replace the hexagon socket head bolt with a new one included in the packing set to avoid air leakage.

Tighten the hexagon socket head bolt evenly to avoid air leakage.

Series MGF Replacement Procedure of Seal 1

⚠ Caution

Disassemble and assemble the cylinder in a clean area. Remove dusts and foreign matters from external surfaces to prevent them from entering the cylinder during disassembly. Perform on a clean cloth.

1. Maintenance

- 1-1. When malfunction of cylinder occurs due to air leakage, replace seal and gasket by referring to procedure shown below.
- 1-2. Replacement procedure
 - a. Remove two hexagon head bolts C 14 and separate upper and lower assemblies.
 - b. Remove six hexagon head bolts A 12 of the upper assembly and remove plate 6.
 - c. Push piston rod assembly (piston rod 5 + piston 4) from rod seal side to pull the piston rod out of tube 2.
 - d. Remove piston seal 20 from piston 4 and replace it by new one. Apply grease on the overall surface of piston seal.
 - e. Remove rod seal 19 from rod cover 3 and replace it by new one. Care should be taken for the orientation of rod seal. Mount it by referring to the internal structural drawing.
 - f. Remove four hexagon head bolts B 13 and separate body 1 and end plate 7.

3. Disassembly

- 3-1. Separation of upper assembly from lower assembly

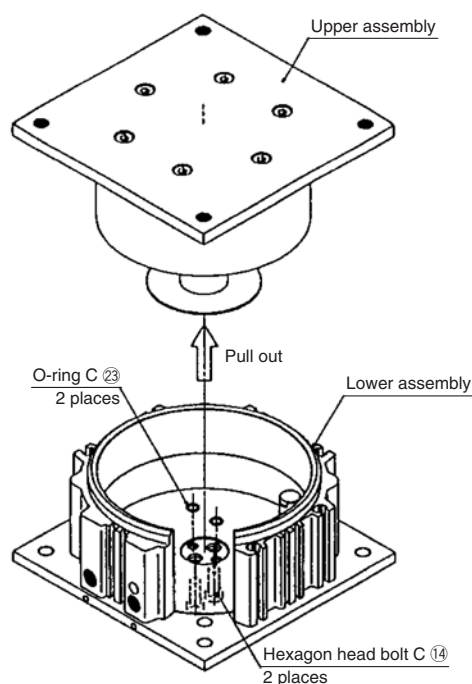

- g. Remove two O-rings C 23 on the end plate side and replace them. Apply grease on the overall surface of gasket.
- h. Remove O-ring B 22 from tube 2 and replace it. Apply grease on the overall surface of gasket.
- i. After all replacement is completed, reassemble the parts. To assemble, follow the disassembling procedure a to h in reverse order.

2. Caution at Assembly and Disassembly

- 2-1. Adhesive is applied to each bolt to prevent loosening. Since powders (adhesive) come out when bolt is removed, care should be taken to prevent them from entering cylinder and sliding part.
- 2-2. Apply the adhesive (moderate strength) to each bolt at assembling.
- 2-3. When the upper assembly is inserted to the lower assembly, bush in the lower assembly is not complete round. Therefore, press the bush by the tube of the upper assembly so that the bush becomes complete round. Care should be taken not to break the bush since broken bush will cause malfunction.
- 2-4. Insert the piston rod assembly to the same position as it was disassembled.
If the piston rod assembly is rotated, lifting and lowering ports would be reversed.

Series MGF Replacement Procedure of Seal 2

3-2. Disassembly of upper assembly

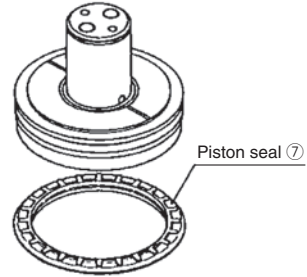
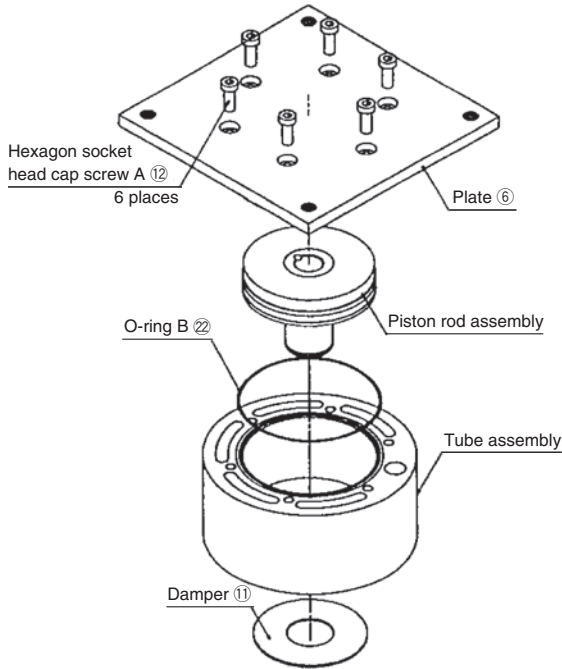

Replacement of Piston Seal

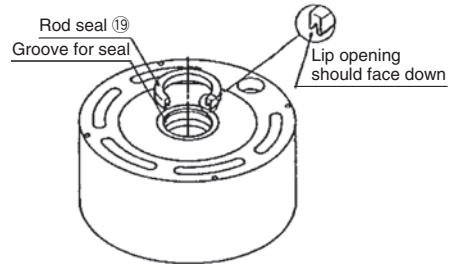

Replacement of Rod Seal

3-3. Disassembly of lower assembly

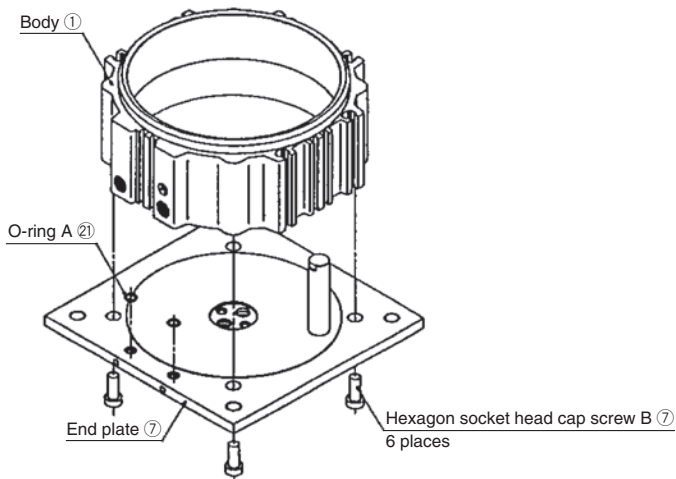

1. Disassembly

⚠ Caution

It decomposes and it is necessary to assemble the cylinder in a clean place.
Please begin working after it wipes off with a clean cloth, etc.

1-1. Loosen and remove the hexagon socket head cap screw and set screw which fix plate, rod. Then pull the plate out of the rod.

At this occasion, screws are sometime hard to unscrew because they are applied Loctite. Pay attention not to damage the hexagon head.

As plates are sometime hard to unscrew as well, use a gear-puller not to damage rods.

Series CXS

With end lock

1-2. Detach the lock unit (5 to 10) from the housing.

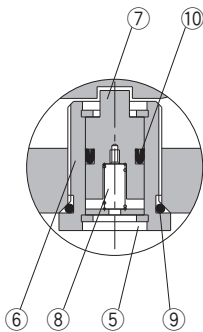

Fig. 1

1-3. Detach retaining rings on the side of head cover using pliers (tool for basic internal retaining ring).

1-4. Hit rods lightly with a plastic hammer, then pull them out from head cover side. At this occasion, they go through bearing part, so make sure there are no burrs or deformation. Burrs or deformations have to be removed by a file or sandpaper.

1-5. Detach the retaining rings on the side of rod cover by using pliers (tool for basic internal retaining ring), then the rod cover away in the same method of 1-4.

1-6. Reusing of packing is not possible. They have to be replaced by the new one at the occasion of reassembling.

At this time, grease has to be applied to packings and kept away from the dust.

Series CXS

With end lock

1-7. O-ring and Lock seal is exchanged. The lock seal removes and exchanges the snap ring.

Reusing of packing is not possible. They have to be replaced by the new one at the occasion of reassembling.

2. Assembly

2-1. Reassemble the parts by reversing the disassembling process.

2-2. Mount the plate to the rod.

It is necessary for the rod to be in the extend state. Apply 0.2 MPa or more from the supply port of the head cover side. Tighten the hexagon socket head cap screw pressing the plate to the rod. Then, tighten the hexagon socket head set screw.

Make sure the product operates with the minimum operating pressure (see table below) without any problem. (The product operates smoothly when it is moved by hand)

Bore size (mm)	6	10	15	20	25	32
Minimum operating pressure (MPa)	0.15	0.1			0.05	

Series CXS

With end lock

After tightening, make sure there is no problem when it is operated in minimum operation pressure (See below) and confirm the lock on the return side.

Bore size (mm)	6	10	15	20	25	32
Minimum operating pressure (MPa)				0.3		

Actuators

Modular F.R.L.
Pressure Control Equipment

Air Preparation
Equipment

Industrial Filters

Replacement
Procedure

Actuators

Modular F.R.L.
Pressure Control Equipment

Industrial Filters

Series **CLG1** Replacement Procedure of Seal ①

1. Disassembly of the Cylinder

1-1. The cylinder needs to be disassembled and assembled in a clean place.

1-2. Refer to the "Replacement Procedure of the Lock Unit" (CLG-1) ① to ③ for disassembly.

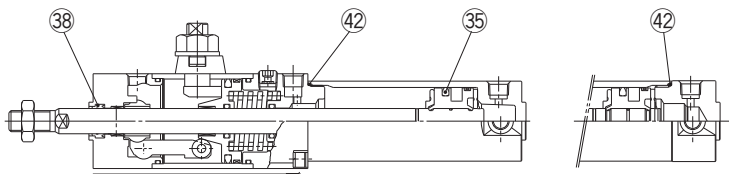

Long stroke

- ③⑧ Rod seal A
- ③⑤ Piston seal
- ④② Cylinder tube gasket

2. Removal of the Seal

③⑧ Rod seal A: Insert a watchmakers screw driver to pull out the seal.

Take care not to damage the seal groove of the cover. (Fig. 1)

③⑤ Piston seal: Remove the piston seal. (Fig. 2)

④② Cylinder tube gasket: Insert a watchmakers screw driver to pull out the seal.

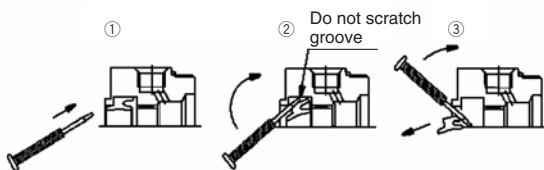

Fig. 1 Removal of rod seal

Squeeze and make a gap to remove it.

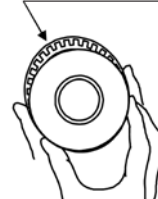

Fig. 2 Removal of piston seal

3. Application of Grease to Seal

3-1. Apply grease slightly to the outer circumference of each seal.

3-2. Fill in the groove of the rod seal with grease.

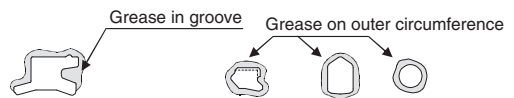

Fig. 3 Grease to the seals

4. Mounting of Seal

③⑧ Rod seal A: Mount the seal in the correct direction.

③⑤ Piston seal: Mount the seal while stretching it as Fig. 5.

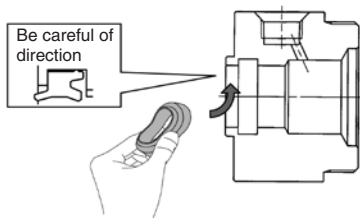

Fig. 4 Installation of rod seal

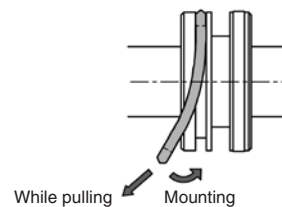

Fig. 5 Installation of piston seal

5. Application of Grease

- ③⑧ Rod seal B: Apply grease to the seal and the inner circumference of the bush. (Fig. 6)
Use a precision screwdriver to apply grease to the small bore diameter while making sure not to leave scratches.
- ③⑤ Piston seal: Rub grease into the seal groove and outer circumference of the seal. (Fig. 7)
- ④② Cylinder tube gasket: Lightly apply grease.
- Cylinder component parts: Apply grease to each component parts of the cylinder in Figure 9.
Appendix table shows the grease amount required for a cylinder with stroke 100.
For your reference, amount taken with a forefinger is about 3 g. (Fig. 8)

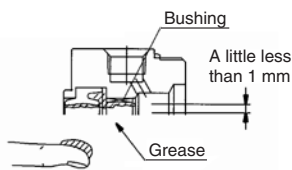

Fig. 6 Rod seal

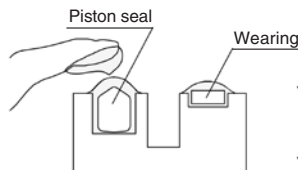

Fig. 7 Piston seal

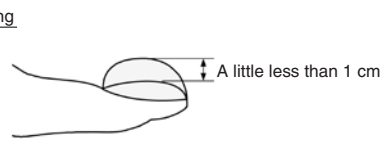

Fig. 8 Grease amount

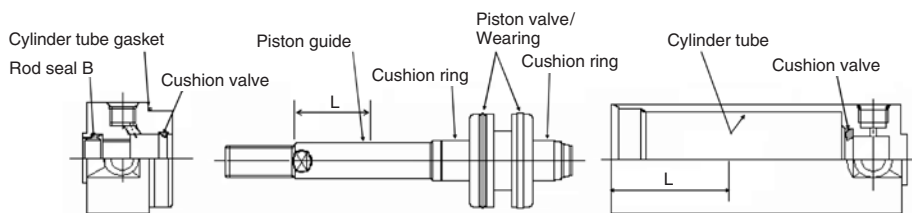

Fig. 9 Grease application points $L = \frac{\text{STROKE}}{2}$ or 100 mm and more

Table. 1 Grease application amount (g)

Stroke	Bore size			
	20	25	32	40
100 st	2	3	3	3 to 4
Extra 50 st	0.5	0.5	0.5	1

6. Reassembly of the Cylinder

- 6-1. Make sure no particles are present. Do not scratch the seals.
- 6-2. Tighten the cover approximately 0-2 degrees more from the original position (where the ports of rod and head covers match).
- 6-3. After completing the assembly, manually check whether the movement is smooth.

7. Replacement Parts

- 7-1. For Series CLG1, lock-up unit (except the long-stroke lock-up) and seals (rod seal B, piston seal, cylinder tube gasket) are replaceable.
- 7-2. Contact SMC sales if it is necessary to replace parts other than those mentioned above.

Series CLG1 Replacement Procedure of Seal 3

8. Replacement Procedure of the Lock Unit

Caution

Series CLG1 lock units are replaceable.
(However, please note that lock units cannot be replaced in the case of long stroke specifications.)

- 8-1. Release the manual lock.
- Loose locking nut.
 - Supply air pressure of 0.3 MPa or more to the lock release port.
 - Turn the wrench flats section of the manual unlocking cam until it stop at the FREE position that is marked on the cam guide.
 - While keeping the wrench flats section in place, tighten the lock nut.

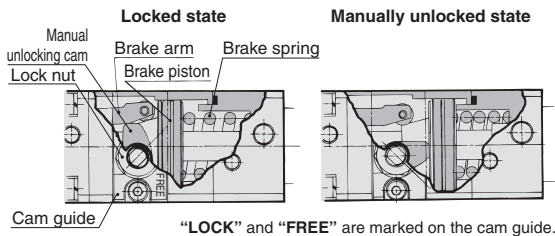

- 8-2. Remove the lock unit by securing the square section of the rod cover or the wrench flats of the tube cover in an apparatus such as a vice, and then loosening the other end with a spanner or adjustable angle wrench, etc.
See the table below for the dimensions of the square section and the wrench flats.

Bore size (mm)	Rod cover square section (mm)	Tube cover wrench flats (mm)
20	38	24
25	45	29
32	45	35.5
40	52	44

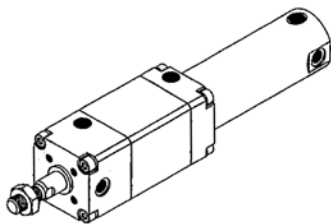

- 8-3. Remove the tube cover.

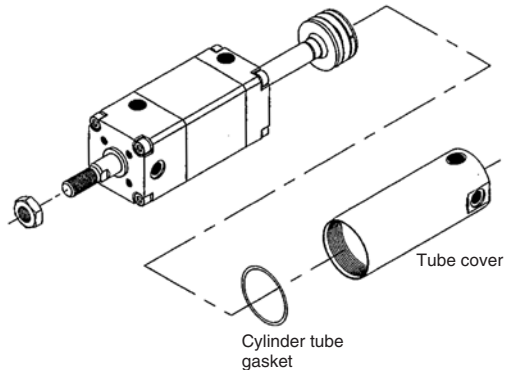

- 8-4. Pull out the piston rod assembly.

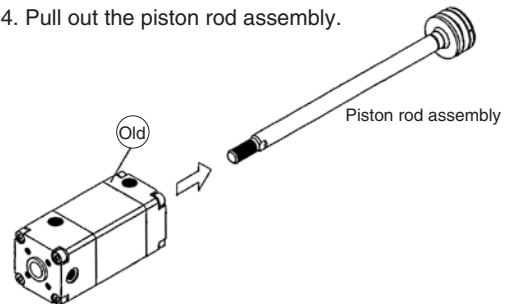

- 8-5. Replace the temporary axis of a new lock unit with the piston rod assembly.

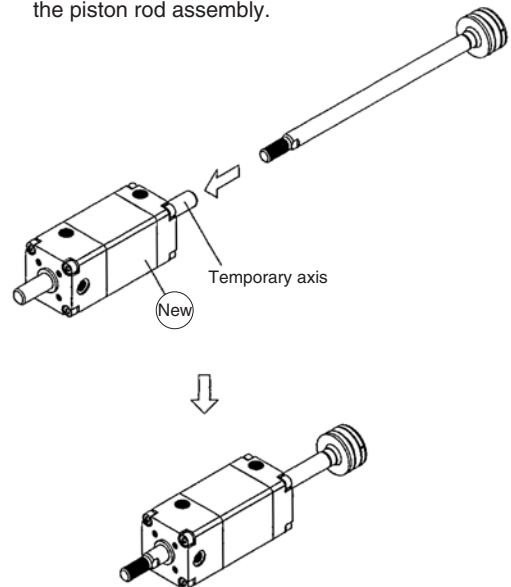

Note) When replacing piston rod assembly with a new lock unit, care should be taken not to cut rod packing B with threads or wrench flats.
Lock the manual unlocking cam before use.

- 8-6. Reassemble by reversing the procedure in steps 8-1. and 8-3. When retightening the sections, turn approximately 2° past their position prior to disassembly.

1. Disassembly of the Cylinder

The cylinder needs to be disassembled and assembled in a clean place.

1-1. Loosen the tie-rod nuts and pull out the four tie-rods.

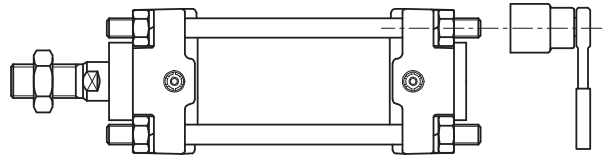
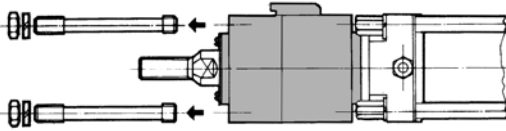

1-2. Open the rubber cap and screw in the unlocking bolt, which is provided as an accessory part. At this time, apply air pressure of 0.2 MPa to 0.3 MPa to disengage the lock and insert the bolt. (The operation to follow can be performed properly and easily with the application of air pressure.) After verifying that the bolt has been inserted properly, pull out the unit from the rod.

Table 1 Work tools

Bore size (mm)	Applicable socket
40, 50	13 (M8)
63	17 (M10)
80, 100	19 (M12)

2. Removal of the seal

2-1. Rod seal

Insert a watchmakers screw driver to pull out the seal.

Take care not to damage the seal groove of the cover. (Fig. 1)

2-2. Piston seal

Remove it as in Fig. 2.

2-3. Tube gasket

Remove it in the same way as Fig. 2.

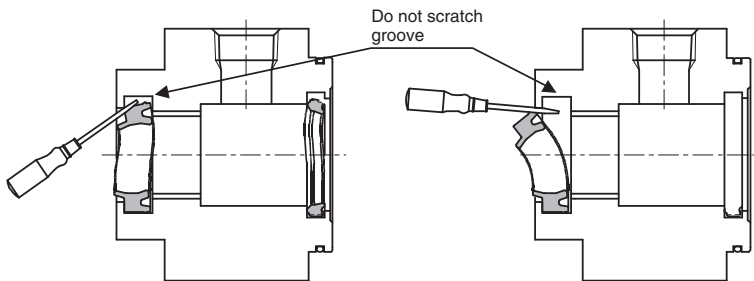

Fig. 1 Removal of rod seal

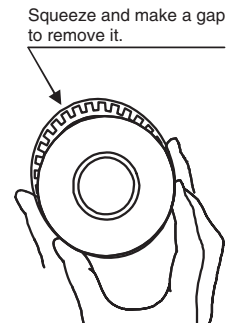

Fig. 2 Removal of piston seal

3. Application of Grease to Seal

3-1. Apply grease slightly to the outer circumference of each seal.

3-2. Fill in the groove of the rod seal with grease.

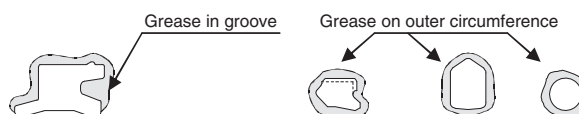

Fig. 3 Grease to the seals

4. Mounting of Seal

4-1. Rod seal

Mount the seal in the correct direction by bending the seal with fingers as Fig. 4.

4-2. Piston seal

Mount the seal while stretching it as in Fig. 5.

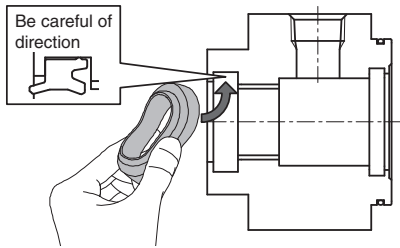

Fig. 4 Installation of rod seal

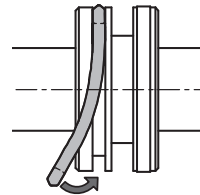

Fig. 5 Installation of piston seal

5. Application of Grease

5-1. Rod seal

Apply grease to the seal and the inner circumference of the bush. (Fig. 6)

5-2. Piston seal

Rub grease into the seal groove and outer circumference of the seal. (Fig. 7)

5-3. Cylinder component parts

Apply grease to each component parts of the cylinder in Figure 9. Appendix table shows the grease amount required for a cylinder with stroke 100. For your reference, amount taken with a forefinger is about 3 g. (Fig. 8)

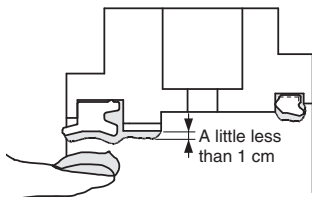

Fig. 6 Rod seal
Cushion seal

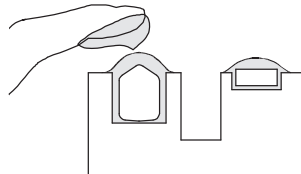

Fig. 7 Piston seal

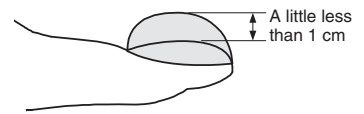

Fig. 8 Grease amount

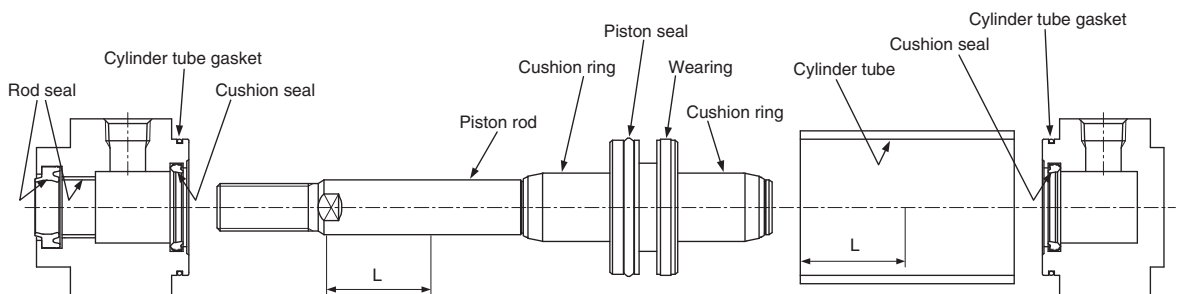

Fig. 9 Grease application points

$$L = \frac{\text{STROKE}}{2} \text{ or } 100 \text{ mm and more}$$

Table 2 Grease application amount (g)

Stroke	Bore size						
	32	40	50	63	80	100	125
100 st	3 to 4	3 to 4	3 to 5	4 to 5	6 to 8	8 to 10	15 to 17
Extra 50 st	1	1	1	1.5	1.5	2	3

6. Reassembly of the Cylinder

- 6-1. Make sure no particles are present. Do not scratch the seals.
- 6-2. To assemble the tie rod to the cylinder, tighten the tie rod to the shorter screw side by hand.
- 6-3. Set the tie rod nuts from the head cover side. Tighten the tie rod nut so that the tensile force is even.

Refer to the appropriate tightening torque of table 3.
Brackets refer to the same table.

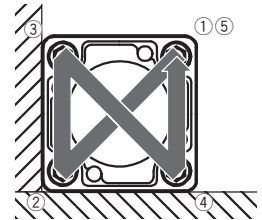

Fig. 10 Tie rod tightening order.

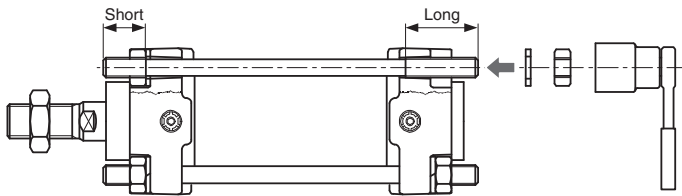
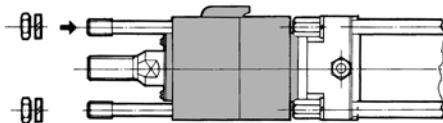

Table 3 Appropriate tightening torque

Bore size (mm)	Appropriate tightening torque (N·m)
40, 50	10.8
63	24.5
80, 100	38.2

- 6-4. Install four tie-rods, with their shorter threaded portion oriented towards the rod cover, and tighten them with uniform torque. Until the installation and adjustment have been completed, never pull out the unlocking bolt (or release the air pressure).



Series CL1 $\varnothing 125$ to $\varnothing 160$ Replacement Procedure of Seal 4

1. Disassembly

- 1-1. Disassembly should be done in a wide space containing little dust.
- 1-2. After removing the cylinder, be sure to protect the end of piping port and rubber hose on the machine side with clean waste to prevent dust from entering.
- 1-3. Disassemble the unit with care to prevent damage to the sliding portion.
- 1-4. Check the double chamfered portion at the rod end for burrs to prevent damage to the seal and the bushing when removing the lock-up unit from the piston rod. If burrs are found, remove them with a "file".
- 1-5. Loosen the tie-rod nuts and pull out the four tie-rods.

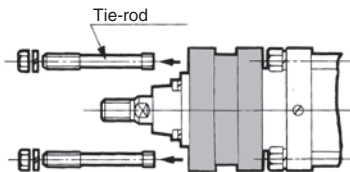

- 1-6. Apply air pressure of 0.2 MPa to 0.3 MPa to disengage the lock and pull out the lock-up unit from the piston rod.

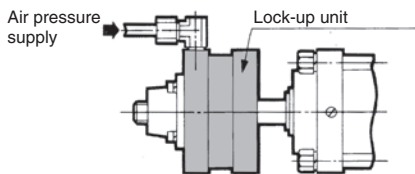

- 1-7. Loosen either of nuts for head side tie rod with "ratchet handle for socket wrench", "T-type slide handle for socket wrench" or "spinner handle for socket wrench", etc. and remove it from the tie rod. Please refer to the table for "socket for socket wrench".

Bore size (mm)	Nut	Applicable socket
125, 140	Class1, M14 x 1.5	JISB4636 Dodecagon22
160	Class1, M16 x 1.5	JISB4636 Dodecagon24

- 1-8. Remove 4 tie rods from cover.
- 1-9. Remove the push plate (rod cover) from the piston rod with care to prevent damage to the seal and bushing.
- 1-10. Pull the piston rod and pull out the piston from the cylinder tube.
- 1-11. Remove the cylinder tube from the head cover.

- 1-12. Disassembly of the rod cover (For the head cover, it should also be in accordance with this procedure.)
 - a. Remove the cylinder tube gasket. When excessive deformation or cut is found with the gasket, replace it.
 - b. Remove the cushion valve from the cover by using "flat blade screwdriver".
(Tool; Screwdriver Nominal size 8 x 150 Normal type, Normal class)
 - c. Remove the cushion valve seal from the cushion valve by using "waste".
 - d. Loosen the hexagon socket head cap screw for push plate by using "hexagon wrench" and remove the push plate. Applicable "Hexagon wrenches" are shown in the table below.

Bore size (mm)	Hexagon socket head cap screw	Nominal size of wrench
125, 140, 160	M8 x 1.25 x 25L	6

- e. Remove the wiper ring. If it cannot be removed by hand, use a small "flat blade screwdriver" and remove it with care to prevent damage to it.
- f. Remove the rod seal by using a small "flat blade screwdriver" with care to prevent damage to it.
- g. Remove the push plate gasket.
- h. Since the cushion seal is pressed fit, air will leak from the portion where the cushion seal is pressed fit due to damage or change in pressing force. Therefore when the cushion seal should be replaced, the rod cover assembly and the head cover assembly should be replaced. (Rod and head covers are not replaceable for type 2 pressure containers. Please consult with SMC for more detail.)
- i. Since the bushing is pressed fit into push plate, it is difficult to remove structurally and even if it is removed, stock for press fit lowers when it is pressed fit again. Therefore when it is replaced, replace the push plate assembly.

2. Replacement Procedure of Seal

2-1. Removal of the seal

Please refer to "1. Disassembly" for dismantling of wiper ring, rod seal, valve seal, tube gasket and push plate gasket.

Since piston seal has a deep groove for sealing, use your hand (not a watchmakers screw driver) and push from one side of seal and pull it out when it lifts off.

2-2. Application of grease

a. Seals: Apply thin coat of grease.

b. Cylinder component

Apply grease to the individual components as the figure below. The table shows the grease amount required for a cylinder with stroke 100.

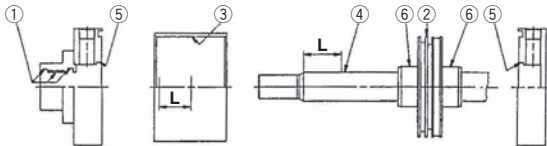

Grease application amount (g)

bore size (mm)	125	140	160	Portion to apply
100 st	15 to 17	20 to 22	24 to 26	① to ⑥
50 st up	3	3	3	③④

For grease, use lithium soap group grease JIS #2

2-3. Mounting of seal

a. Wiper ring/Rod seal

Mount in correct direction.

b. Seals other than wiper ring

After mounting seals, apply grease on inside diameter surfaces of bushing (rubbing grease into surface).

3. Assembly

3-1. Before assembling cylinder, be sure to clean each part to remove dust.

3-2. Before assembling, apply rod, bushing, tube and seal with enough grease.

3-3. For rusty part, remove the rust completely.

3-4. Assembly should be done in a clean place with care to prevent foreign matters from entering.

3-5. Mount seal with care to prevent damage to it.

3-6. Insert piston into tube or rod into bushing with care to prevent damage to each seal.

3-7. Tighten tie rod and bolt with appropriate torque shown in the table below.

Tightening torque (N·m)

Bore size (mm)		125	140	160
Tie rod	Steel tube	49		75.5
	Aluminum tube		39.2	62.8
Push plate bolt		11		

3-8. Insert the lock-up unit to the piston rod while the lock is released with the air pressure of 0.2 to 0.3 Mpa, Install the four tie-rods, with their shorter threaded portion oriented towards the rod cover, and tighten them with uniform torque.

Maintain the application of air pressure until the installation and adjustment have been completed, and never actuate the lock in the meantime.

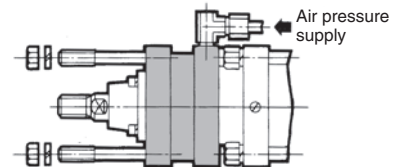

Series CNG Replacement Procedure of Seal 1

1. Disassembly of the Cylinder

1-1. The cylinder needs to be disassembled and assembled in a clean place.

1-2. Refer to the "Replacement Procedure of the Lock Unit" (CNG-3) ① to ③ for disassembly.

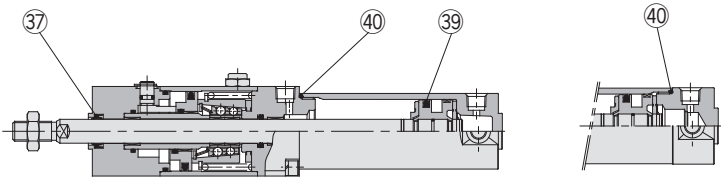

Long stroke

- ③7 Rod seal A
- ③9 Piston seal
- ④0 Cylinder tube gasket

2. Removal of the Seal

- ③7 Rod seal A: Insert a watchmakers screw driver to pull out the seal. Take care not to damage the seal groove of the cover. (Fig. 1)
- ③8 Piston seal: Remove the piston seal. (Fig. 2)
- ④0 Cylinder tube gasket: Insert a watchmakers screw driver to pull out the seal.

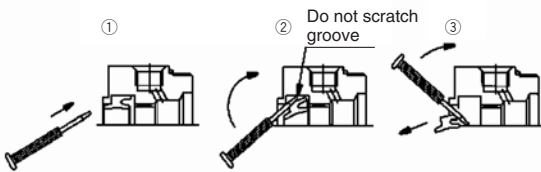

Fig. 1 Removal of rod seal

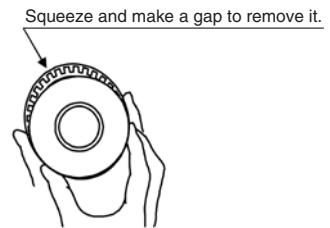

Fig. 2 Removal of piston seal

3. Application of Grease to Seal

3-1. Apply grease slightly to the outer circumference of each seal.

3-2. Fill in the groove of the rod seal with grease.

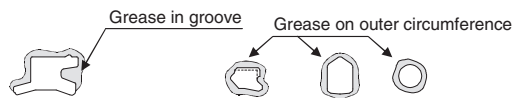

Fig. 3 Grease to the seals

4. Mounting of Seal

- ③7 Rod seal A: Mount the seal in the correct direction.
- ③9 Piston seal: Mount the seal while stretching it as Fig. 5.

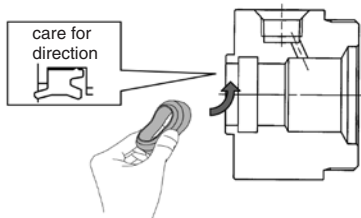

Fig. 4 Installation of rod seal

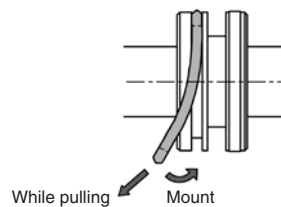

Fig. 5 Installation of piston seal

5. Application of Grease

- ③7 Rod seal A: Apply grease to the seal and the inner circumference of the bush. (Fig. 6)
Use a precision screwdriver to apply grease to the small bore diameter while making sure not to leave scratches.
- ③9 Piston seal: Rub grease into the seal groove and outer circumference of the seal. (Fig. 7)
- ③0 Cylinder tube gasket: Lightly apply grease.
- Cylinder component parts: Apply grease to each component parts of the cylinder in Figure 9.
Appendix table shows the grease amount required for a cylinder with stroke 100.
For your reference, amount taken with a forefinger is about 3 g. (Fig. 8)

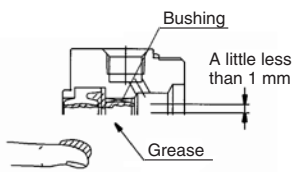

Fig. 6 Rod seal

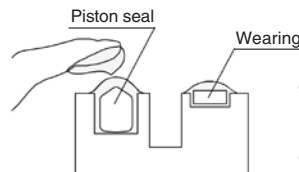

Fig. 7 Piston seal

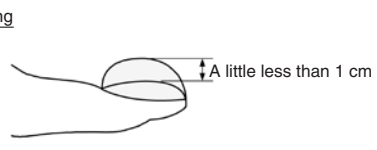

Fig. 8 Grease amount

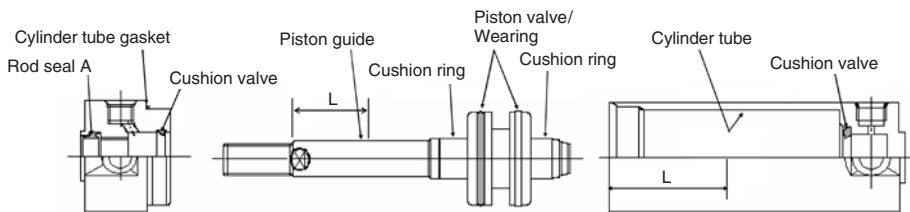

Fig. 9 Grease application points $L = \frac{\text{STROKE}}{2}$ or 100 mm and more

Grease application amount (g)

Stroke	Bore size			
	20	25	32	40
100 st	2	3	3	3 to 4
Extra 50 st	0.5	0.5	0.5	1

6. Reassembly of the Cylinder

- 6-1. Make sure no particles are present. Do not scratch the seals.
- 6-2. Tighten the cover approximately 0-2 degrees more from the original position (where the ports of rod and head covers match).
- 6-3. After completing the assembly, manually check whether the movement is smooth.

7. Replacement Parts

- 7-1. For Series CNG, lock-up unit (except the long-stroke) and seal (rod seal B, piston seal, cylinder tube gasket) are replaceable.
- 7-2. Contact SMC sales if it is necessary to replace parts other than those mentioned above.

Series CNG Replacement Procedure of Seal 3

8. Replacement Procedure of the Lock Unit

⚠ Caution

Series CNG lock units are replaceable.

(However, please note that lock units cannot be replaced in the case of long stroke specifications.)

8-1. Remove the lock unit by securing the square section of the rod cover or the wrench flats of the tube cover in an apparatus such as a vice, and then loosening the other end with a spanner or adjustable angle wrench, etc.

See the table below for the dimensions of the square section and the wrench flats.

Bore size (mm)	Rod cover square section (mm)	Tube cover wrench flats (mm)
20	38	24
25	45	29
32	45	35.5
40	52	44

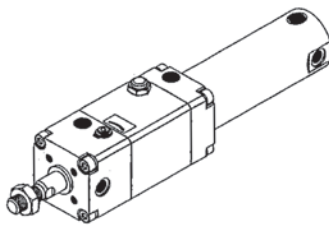

8-2. Remove the tube cover.

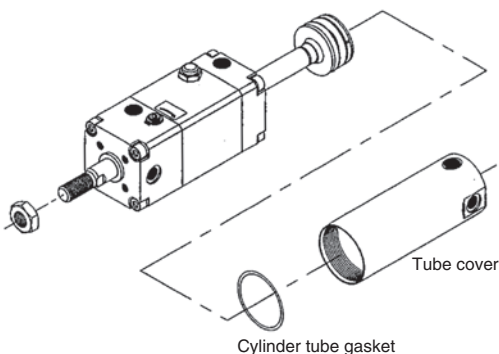

8-3. Apply compressed air of 0.3 MPa or more to the unlocking port, and pull out the piston rod assembly.

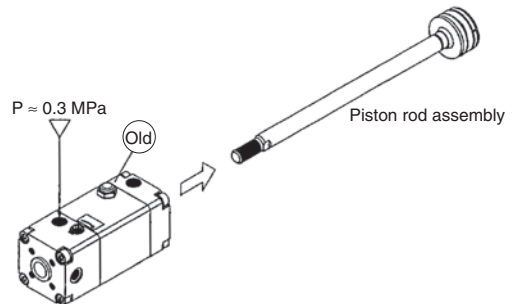

8-4. Similarly apply compressed air of 0.3 MPa or more to the unlocking port of the new lock unit, and replace the temporary axis with the previous piston rod assembly.

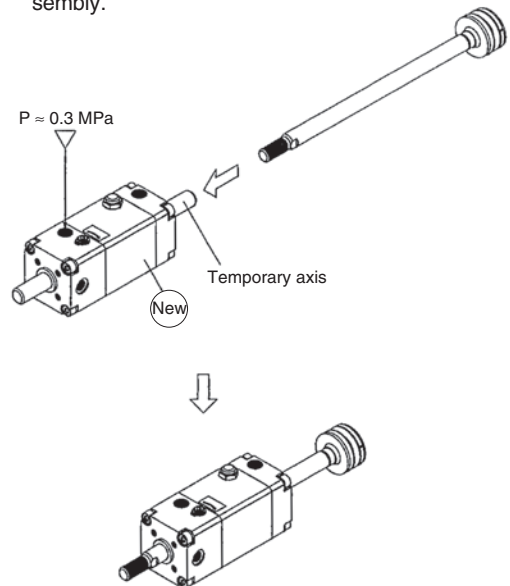

Note) When replacing piston rod assembly with a new lock unit, care should be taken not to cut rod packing B with threads or wrench flats.

Be sure to keep applying compressed air with a pressure of at least 0.3 MPa to the lock releasing port when replacing the temporary axis of a new lock unit with a piston rod assembly.

If the compressed air applied to the lock releasing port is released (when it is in the lock condition) while the temporary rod and the piston rod assembly are removed from the lock unit, the brake shoe will be deformed and it will become impossible to insert the piston rod assembly, which will make the lock unit impossible to use.

8-5. Reassemble by reversing the procedure in steps 8-1. and 8-2. When retightening the sections, turn approximately 2° past their position prior to disassembly.

1. Disassembly of the Cylinder

The cylinder needs to be disassembled and assembled in a clean place.

Series MNB

How to Replace Lock Units ② (Page 354)

Refer to a to c.

Table 1 Work tools

Bore size (mm)	Width across flats of a hexagon wrench	
	When removing the support bracket	When removing the tie-rod nut
32, 40	4	6
50, 63	5	8
80, 100	6	10
125	8	12

Series CNA2

How to Replace Lock Units ② (Page 355)

Refer to a to c.

Table 2 Work tools

Bore size (mm)	Applicable socket
40, 50	13 (M8)
63	17 (M10)
80, 100	19 (M12)

2. Removal of the Seal

2-1. Rod seal, cushion seal

Insert a watchmakers screw driver to pull out the seal.

Take care not to damage the seal groove of the cover. (Fig. 1)

2-2. Piston seal

Remove it as in Fig. 2.

2-3. Tube gasket

Remove it in the same way as Fig. 2.

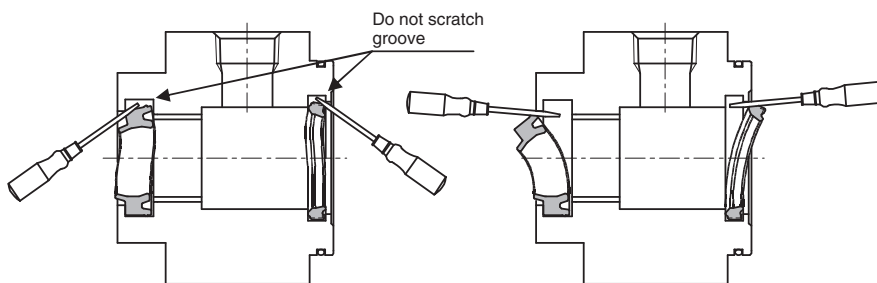

Fig. 1 Removal of rod seal, cushion seal

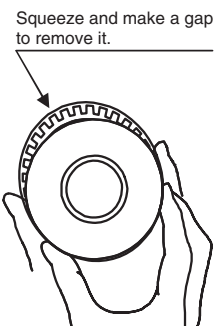

Fig. 2 Removal of piston seal

3. Application of Grease to Seal

3-1. Apply grease slightly to the outer circumference of each seal.

3-2. Fill in the groove of the rod seal with grease.

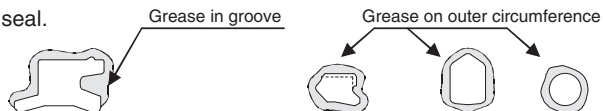

Fig. 3 Grease to the seal

Actuators

Modular F.R.L.
Pressure Control Equipment

Air Preparation
Equipment

Industrial Filters

Replacement
Procedure

Actuators

Modular F.R.L.
Pressure Control Equipment

Industrial Filters

4. Mounting of Seal

4-1. Rod seal, cushion seal

Mount the seal in the correct direction by bending the seal with fingers as Fig. 4.

4-2. Piston seal

Mount the seal while stretching it as in Fig. 5.

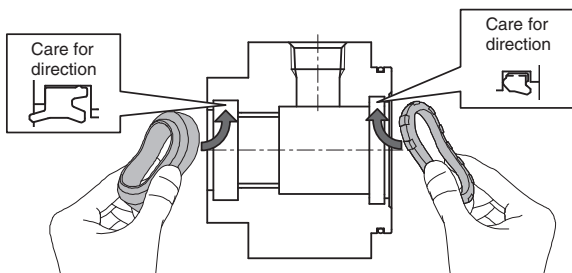

Fig. 4 Installation of rod seal, cushion seal

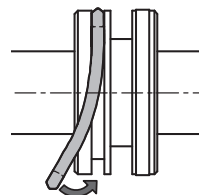

Fig. 5 Installation of piston seal

5. Application of Grease

5-1. Rod seal, cushion seal

Apply grease to the seal and the inner circumference of the bush. (Fig. 6)

5-2. Piston seal

Rub grease into the seal groove and outer circumference of the seal. (Fig. 7)

5-3. Cylinder component parts

Apply grease to each component parts of the cylinder in Figure 9. Appendix table shows the grease amount required for a cylinder with stroke 100. For your reference, amount taken with a forefinger is about 3 g. (Fig. 8)

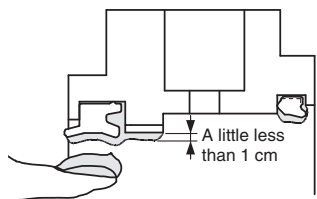

Fig. 6 Rod seal
Cushion seal

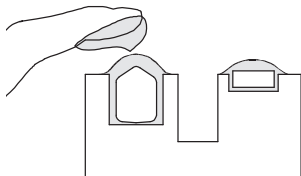

Fig. 7 Piston seal

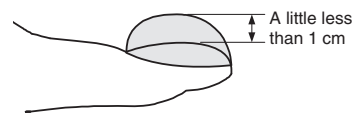

Fig. 8 Grease amount

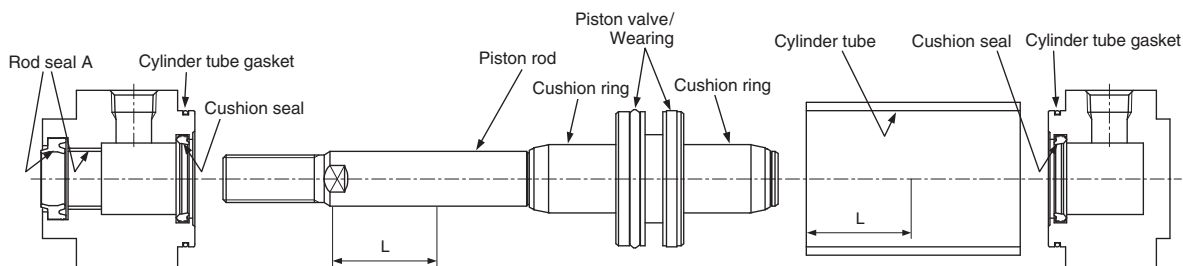

Fig. 9 Grease application points

$$L = \frac{\text{Stroke}}{2} \text{ or } 100 \text{ mm and more}$$

Grease application amount (g)

Stroke	Bore size						
	32	40	50	63	80	100	125
100 st	3 to 4	3 to 4	3 to 5	4 to 5	6 to 8	8 to 10	15 to 17
Extra 50 st	1	1	1	1.5	1.5	2	3

6. Reassembly of the Cylinder

- 6-1. Make sure no particles are present. Do not scratch the seals.
- 6-2. Assemble the cylinder following the Replacement Procedure of Lock-up Unit 2, c through a.
 - MNB (Page 354)
 - CNA2 (Page 355)
- 6-3. To assemble the tie rod to the cylinder, tighten the tie rod to the shorter screw side by hand from the head cover side.
- 6-4. Set the tie rod nuts. Tighten the tie rod nut so that the tensile force is even. Refer to the appropriate tightening torque of table 4 and 5. Brackets refer to the same table.

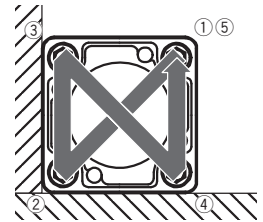

Fig. 10 Tie rod tightening order

Series *MNB*

Table 4 Appropriate tightening torque

Bore size (mm)	Appropriate tightening torque (N·m)
32, 40	5.1
50, 63	11.0
80, 100	25.0
125	30.0

Series *CNA2*

Table 5 Appropriate tightening torque

Bore size (mm)	Appropriate tightening torque (N·m)
40, 50	10.8
63	24.5
80, 100	38.2

Actuators

Modular F.R.L.
Pressure Control Equipment

Air Preparation
Equipment

Industrial Filters

Replacement
Procedure

Actuators

Modular F.R.L.
Pressure Control Equipment

Industrial Filters

7. Replacement Procedure of the Lock Unit

Series MNB

Warning

Although the MNB series lock unit is replaceable, Do not disassemble the lock unit.

1. Series MNB lock units are replaceable.
2. How to replace the lock unit
 - a. Loosen the cylinder head cover tie rod nuts (four) with a hexagon wrench. Refer to the table below for applicable.

Bore size (mm)	Width across flats of a hexagon wrench
32, 40	6
50, 63	8
80, 100	10

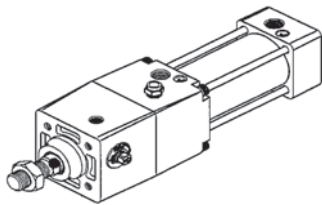

- b. Remove the tie rods, head cover and cylinder tube

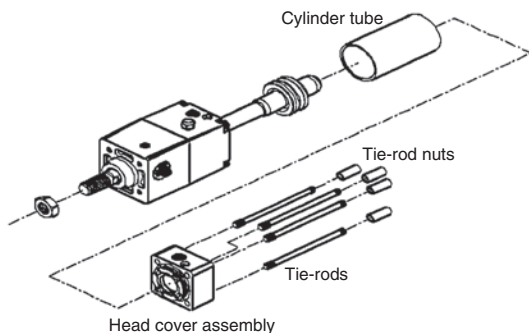

- c. Apply 0.3 MPa or more of pressure to the lock release port to pull out the piston rod assembly.

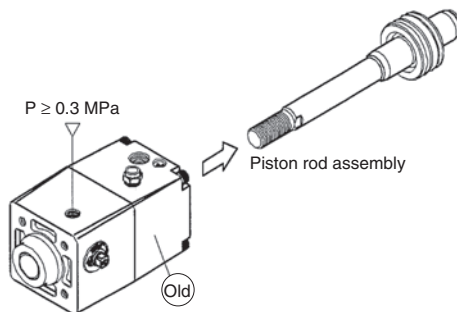

- d. Apply 0.3 MPa or more of pressure to new lock unit lock release port to change the piston rod assembly to the tentative rod.

Note1) Attention should be taken not to cut rod packing B with screws and the spanner flat when replacing the piston rod Assembly to new lock unit.

Note2) Be sure to keep applying compressed air with a pressure of at least 0.3 MPa to the lock releasing port when replacing the temporary axis of a new lock unit with a piston rod assembly.

If the compressed air applied to the lock releasing port is released (when it is in the lock condition) while the temporary rod and the piston rod assembly are removed from the lock unit, the brake shoe will be deformed and it will become impossible to insert the piston rod assembly, which will make the lock unit impossible to use.

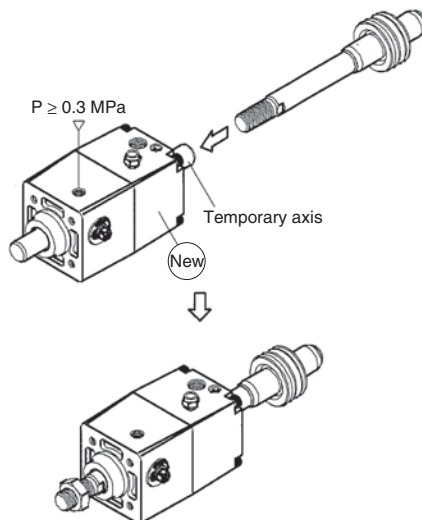

- e. Reassemble in reverse order from b to a

Caution

Don't apply grease nor oil to the piston rod surface.

Series MNB/CNA2 Replacement Procedure of Seal 5

Series CNA2

1. CNA2 series lock unit is replaceable.
2. How to replace the lock unit
 - a. Loosen the tie-rod nuts (4 pieces) on the cylinder head cover side by using a socket wrench.
For applicable socket, refer to the below table.

Bore size (mm)	Nut mounting bracket		
	Nut	Width across flats dimension	Socket
40, 50	JISB1181 Class2 M8 x 1.25	13	JISB4636 + 2-point angle socket 13
63	JISB1181 Class2 M10 x 1.25	17	JISB4636 + 2-point angle socket 17
80, 100	JISB1181 Class2 M12 x 1.75	19	JISB4636 + 2-point angle socket 19

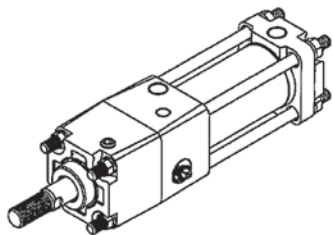

- b. Remove the tie rods, head cover and cylinder tube.

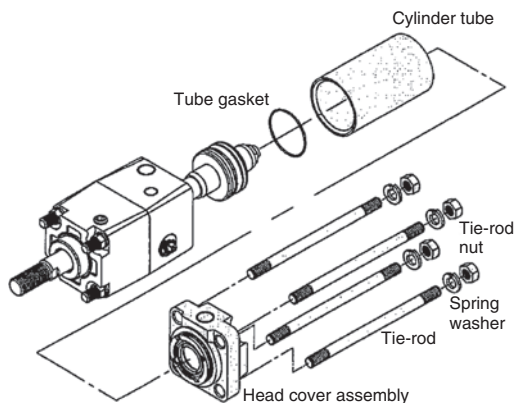

- c. Apply 0.3 MPa or more of compressed air to the unlocking port, and pull out the piston rod assembly.

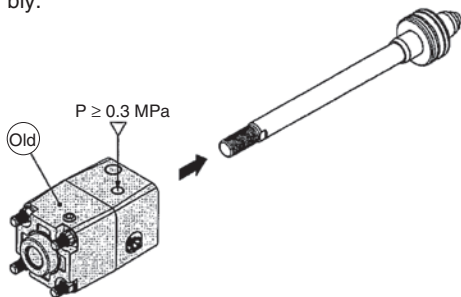

- d. Similarly, apply 0.3 MPa or more of compressed air to the unlocking port of the new lock unit, and replace the new lock unit's temporary axis with the previous piston rod assembly.

Note1) Attention should be taken not to cut rod seal B with screws and the spanner flat when replacing the piston rod assembly to new lock unit.

Note2) Be sure to keep applying compressed air with a pressure of at least 0.3MPa to the lock releasing port when replacing the temporary axis of a new lock unit with a piston rod assembly.

If the compressed air applied to the lock releasing port is released (when it is in the lock condition) while the temporary rod and the piston rod assembly are removed from the lock unit, the brake shoe will be deformed and it will become impossible to insert the piston rod assembly, which will make the lock unit impossible to use.

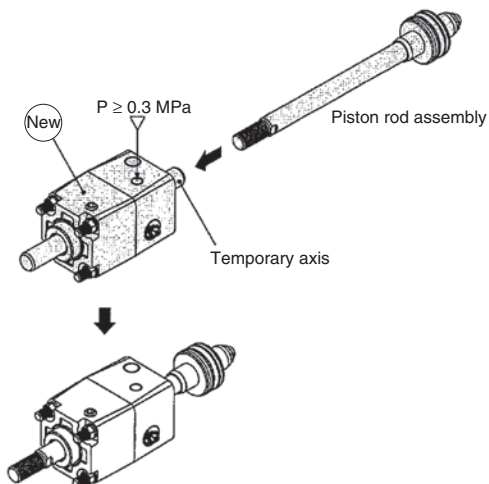

- e. Reassemble in reverse order from step b to a.

⚠ Caution

Don't apply grease nor oil to the piston rod surface.

Actuators

Modular F.R.L.
Pressure Control Equipment

Air Preparation
Equipment

Industrial Filters

Replacement
Procedure

Actuators

Modular F.R.L.
Pressure Control Equipment

Industrial Filters

Series CNS Replacement Procedure of Seal ①

1. Disassembly

- 1-1. Disassembly should be done in a wide space containing little dust.
- 1-2. After removing the cylinder, be sure to protect the end of piping port and rubber hose on the machine side with clean waste to prevent dust from entering.
- 1-3. Disassemble the unit with care to prevent damage to the sliding portion.
- 1-4. Check the double chamfered portion at the rod end for burrs to prevent damage to the seal and the bushing when removing the lock unit from the piston rod. If burrs are found, remove them with a "file".
- 1-5. Remove the lock unit according to section 4, Replacing Procedures of Lock Unit.
- 1-6. Loose either of nuts for head side tie rod with "ratchet handle for socket wrench", "T-type slide handle for socket wrench" or "spinner handle for socket wrench", etc. and remove it from the tie rod. Refer to the table for "socket for socket wrench".

Bore size (mm)	Nut	Applicable socket
125, 140	Class1, M14 x 1.5	JISB4636 Dodecagon22
160	Class1, M16 x 1.5	JISB4636 Dodecagon24

- 1-7. Remove 4 tie rods from cover.
- 1-8. Remove the rod cover from the piston rod with care to prevent damage to the seal and bushing.
- 1-9. Pull the piston rod and pull out the piston from the cylinder tube.
- 1-10. Remove the cylinder tube from the head cover.
Remove the wiper ring of the lock unit. If it cannot be removed by hand, use a small "flat blade screwdriver" and remove it with care to prevent damage to it.
- 1-11. Disassembly of the rod cover (For the head cover, it should also be in accordance with this procedure.)
 - a. Remove the cylinder tube gasket. When excessive deformation or cut is found with the gasket, replace it.
 - b. Remove the cushion valve from the cover by using "flat blade screwdriver".
(Tool; Screwdriver nominal size 8x150 Normal type, Normal class)
 - c. Remove the cushion valve seal from the cushion valve by using "waste".
 - d. Loosen the hexagon socket head cap screw for push plate B by using "hexagon wrench" and remove the push plate D. Applicable "Hexagon wrenches" are shown in the table below.
 - e. Remove the rod seal by using a small "flat blade screwdriver" with care to prevent damage to it.
 - f. Remove the push plate gasket.

Bore size (mm)	Hexagon socket head cap screw	Nominal size of wrench
125, 140, 160	M8 x 1.25 x 25L	6

- g. Since the cushion seal is pressed fit, air will leak from the portion where the cushion seal is pressed fit due to damage or change in pressing force. Therefore when the cushion seal should be replaced, the rod cover assembly and the head cover assembly should be replaced.

2. Replacement Procedure of Seal

2-1. Removal of the seal

Please refer to "1. Disassembly" for dismantling of wiper ring, rod seal, valve seal, tube gasket and push plate gasket.

Since piston seal has a deep groove for sealing, use your hand (not a watchmakers screw driver) and push from one side of seal and pull it out when it lifts off.

2-2. Application of grease

- a. Seals: Apply thin coat of grease.
- b. Cylinder component

Apply grease to the individual components as the figure below. The table shows the grease amount required for a cylinder with stroke 100.

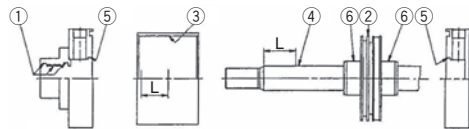

Grease application amount (g)

Bore size (mm)	125	140	160	Portion to apply
100 st	15 to 17	20 to 22	24 to 26	① to ⑥
50 st extra	3	3	3	③④

For grease, use lithium soap group grease JIS #2.

2-3. Mounting of seal

- a. Wiper ring/Rod seal
Mount in correct direction.
- b. Seals other than wiper ring
After mounting seals, apply grease on inside diameter surfaces of bushing (rubbing grease into surface).

Series CNS Replacement Procedure of Seal ②

3. Assembly

- 3-1. Before assembling cylinder, be sure to clean each part to remove dust.
- 3-2. Before assembling, apply rod, bushing, tube and seal with enough grease.
- 3-3. For rusty part, remove the rust completely.
- 3-4. Assembly should be done in a clean place with care to prevent foreign matters from entering.
- 3-5. Mount seal with care to prevent damage to it.
- 3-6. Insert piston into tube or rod into bushing with care to prevent damage to each seal.
- 3-7. Tighten tie rod and bolt with appropriate torque shown in the table below.

Tightening torque (N·m)

Bore size (mm)		125	140	160
Tie rod	Steel tube	49		75.5
	Aluminum tube	39.2		62.8
Push plate bolt		11		

4. Replacement Procedure of the Lock Unit

- 4-1. Lock unit for Series CNS can be replaced.
- 4-2. Replacing procedures of lock unit
 - a. Loosen tie-rod nut (4 pieces) on rod cover side of cylinder with socket wrench.

Bore size (mm)	Nut	Dimension of width across flats	Socket
125, 140	JIS B1181 M14 x 1.5	22	JIS B4636 Socket22
160	JIS B1181 M16 x 1.5	24	JIS B4636 Socket24

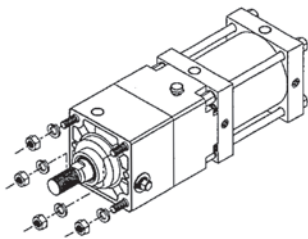

- b. Remove lock unit by applying compressed air over 0.3 MPa to lock release port.

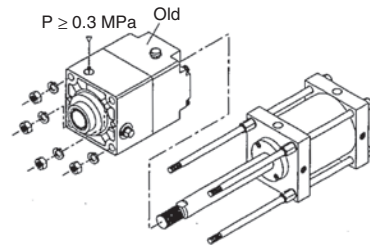

- c. Also apply compressed air over 0.3 MPa to new lock unit and replace piston rod of cylinder with temporary shaft.

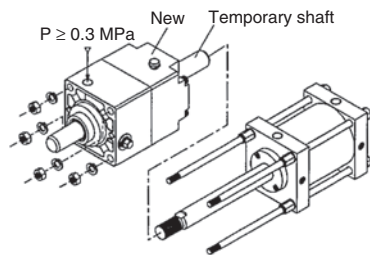

Note) To replace the piston rod assembly with the temporary shaft of a new lock unit, make sure that the compressed air of 0.3 MPa or higher is kept applied to the lock release port.

If the compressed air is exhausted (locked state) while the temporary shaft and piston rod assembly are pulled out from the lock unit, a brake shoe will be deformed and the piston rod assembly cannot be inserted. This makes the lock unit unusable.

- d. Tighten tie-rod nut (4 pieces) on cylinder rod side with socket wrench.

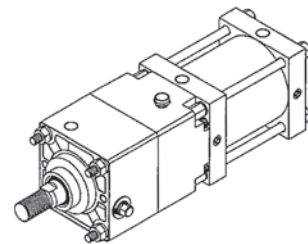

⚠ Warning

Customer shall not disassemble the CNS series lock unit.

1. Because of powerful spring installed, do not loosen or remove hexagon socket head cap screws fixing covers A and B (parts may be shot out).
2. Please consult with our sales person if disassembly and repair are necessary.

⚠ Caution

Apply grease and oil to the surface of piston rod only when it is necessary.

Series **CLS** Replacement Procedure of Seal 1

1. Disassembly

- 1-1. Disassembly should be done in a wide space containing little dust.
- 1-2. After removing the cylinder, be sure to protect the end of piping port and rubber hose on the machine side with clean waste to prevent dust from entering.
- 1-3. Disassemble the unit with care to prevent damage to the sliding portion.
- 1-4. Check the double chamfered portion at the rod end for burrs to prevent damage to the seal and the bushing when removing the lock unit from the piston rod. If burrs are found, remove them with a "file".
Remove the lock unit according to "Appendix. Replacement Procedures of Lock Unit".
- 1-5. Side of the head of nuts for tie rod with "ratchet handle for socket wrench", "T-type slide handle for socket wrench" or "spinner handle for socket wrench", etc. and remove it from the tie rod. Refer to the table for "socket for socket wrench".

Bore size (mm)	Nut	Applicable socket
125-140	Class1, M14 x 1.5	JISB4636 Dodecagon22
160	Class1, M16 x 1.5	JISB4636 Dodecagon24
180	Class1, M18 x 1.5	JISB4636 Dodecagon27
200	Class1, M20 x 1.5	JISB4636 Dodecagon30
250	Class1, M24 x 1.5	JISB4636 Dodecagon36

- 1-6. Remove 4 tie rods from cover.
- 1-7. Remove the rod cover from the piston rod with care to prevent damage to the seal and bushing.
- 1-8. Pull the piston rod and pull out the piston from the cylinder tube.
- 1-9. Remove the cylinder tube from the head cover.
Remove the wiper ring of lock unit. If it cannot be removed by hand, use a small "flat blade screwdriver" and remove it with care to prevent damage to it.
- 1-10. Disassembly of the rod cover (For the head cover, it should also be in accordance with this procedure.)
 - a. Remove the cylinder tube gasket. When excessive deformation or cut is found with the gasket, replace it.
 - b. Remove the cushion cover from the cover by using "flat blade screwdriver".
(Tool; Screwdriver nominal size 8x150 normal type, normal class)
 - c. Remove the cushion valve seal from the cushion valve by using "waste".
 - d. Loosen the hexagon socket head cap screw for push plate by using "hexagon wrench" and remove the push plate. Applicable "Hexagon wrenches" are shown in the table right above.

Bore size (mm)	Hexagon socket head cap screw	Nominal size of wrench
125, 140, 160	M8 x 1.25 x 16L	6
180, 200	M10 x 1.5 x 18L	8
250	M12 x 1.75 x 22L	10

- e. Remove the rod seal by using a small "flat blade screwdriver" with care to prevent damage to it.
- f. Remove the push plate gasket.
- g. Since the cushion seal is pressed fit, air will leak from the portion where the cushion seal is pressed fit due to damage or change in pressing force. Therefore when the cushion seal should be replaced, the rod cover assembly and the head cover assembly should be replaced.

2. Replacement Procedure of Seal

2-1. Removal of the seal

Please refer to "1. Disassembly" for dismantling of wiper ring, rod seal, valve seal, tube gasket and push plate gasket.

Since piston seal has a deep groove for sealing, use your hand (not a screw driver) and push from one side of seal and pull it out when it lifts off.

2-2. Application of grease

- a. Seals: Apply thin coat of grease.
- b. Cylinder component

Apply grease to the individual components as the figure below. The table shows the grease amount required for a cylinder with stroke 100.

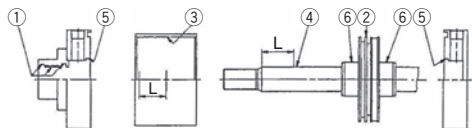

Grease application amount (g)

Bore size (mm)	125	140	160	180	200	250	Portion to apply
100 st	15 to 17	20 to 22	24 to 26	27 to 29	30 to 32	33 to 35	① to ⑥
50 st extra	3	3	3	4	4	5	③④

For grease, use lithium soap group grease JIS #2.

2-3. Mounting of seal

- a. Wiper ring/Rod seal
Mount in correct direction.
- b. Seals other than wiper ring
After mounting seals, apply grease on inside diameter surfaces of bushing (rubbing grease into surface).

Series CLS Replacement Procedure of Seal 2

3. Assembly

- 3-1. Before assembling cylinder, be sure to clean each part to remove dust.
- 3-2. Before assembling, apply rod, bushing, tube and seal with enough grease.
- 3-3. For rusty part, remove the rust completely.
- 3-4. Assembly should be done in a clean place with care to prevent foreign matters from entering.

Tightening torque (N·m)

Bore size (mm)		125	140	160	180	200	250
Tie rod	Steel tube	49	75.5	103	147.1	254	
	Aluminum tube	39.2	62.8	92.7	132.4	—	
Push plate bolt		11		22		38	

- 3-5. Mount seal with care to prevent damage to it.
- 3-6. Insert piston into tube or rod into bushing with care to prevent damage to each seal.
- 3-7. Tighten tie rod and bolt with appropriate torque shown in the table below.

4. Replacement Procedure of the Lock Unit

4-1. Lock unit for the CLS series can be replaced.

⚠ Caution

1. Never disassemble the lock unit.

A heavy duty spring is contained in part of the unit, which presents a serious hazard if disassembly is performed incorrectly.

In addition, the lock unit is adjusted before shipment. If readjustment is not performed correctly after reassembly, a serious danger will be created, as performance will not meet specifications.

2. Cylinder body and the lock unit are heavy materials. Two or more persons are required for the replacement of the unit after cleaning up the working environment.

3. The brake tube assembly and the lock unit can be separated. Do not disassemble any other parts.

4-2. Loosen the four tie-rod nuts on the rod cover side of the cylinder using the socket wrench.

Refer to the table below for the size of the tie-rod nut.

Bore size (mm)	Tie-rod nut	Width across flats dimension	Socket
125, 140	JISB1181 Class 1 M14 x 1.5	22	JISB4636 + 2-point angle socket22
160	JISB1181 Class 1 M14 x 1.5	24	JISB4636 + 2-point angle socket24
180	JISB1181 Class 1 M14 x 1.5	27	JISB4636 + 2-point angle socket27
200	JISB1181 Class 1 M14 x 1.5	30	JISB4636 + 2-point angle socket30
250	JISB1181 Class 1 M14 x 1.5	36	JISB4636 + 2-point angle socket36

4-3. Release the lock by hand or apply 0.25 MPa to the unlocking port and pull out the lock unit from the base cylinder.

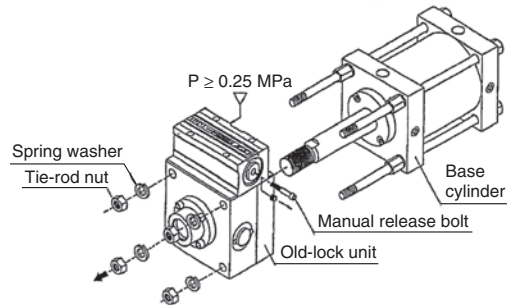

4-4. Remove four holding bolts for the new lock unit brake tube assembly and remove the brake tube assembly.

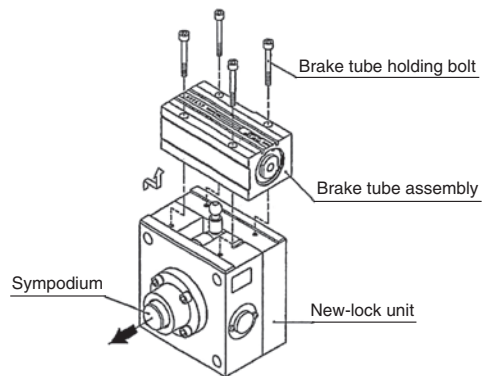

4-5. Pull out the temporary shafts from the lock unit and insert the lock unit to the base cylinder.

⚠ Caution

1. Take care not to damage the inner surface of the brake shoe with the width across flats during insertion of the lock unit.

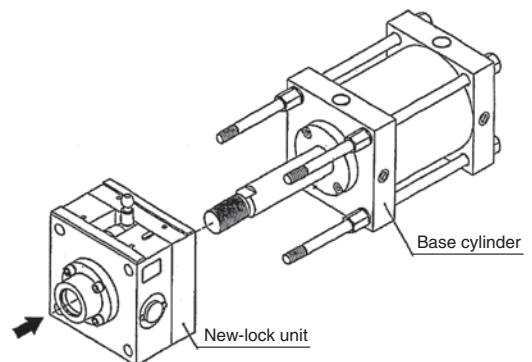

Actuators

Modular F.R.L.
Pressure Control Equipment

Air Preparation
Equipment

Industrial Filters

Replacement
Procedure

Actuators

Modular F.R.L.
Pressure Control Equipment

Industrial Filters

Series *CLS* Replacement Procedure of Seal 3

4-6. After making sure that the key is mounted to the specified location, assemble the brake tube assembly and fix it with holding bolts.

(N·m)		
Bore size (mm)	Bolt size	Tightening torque (standard)
125, 140	M6	4.8
160	M8	11.9
180	M8	11.9
200	M10	24.5
250	M12	42

4-7. Lastly, tighten the tie-rod nuts.

(N·m)		
Bore size (mm)	Bolt size	Tightening torque (standard)
125, 140	M14	34.3
160	M16	53.9
180	M18	73
200	M20	102
250	M24	180

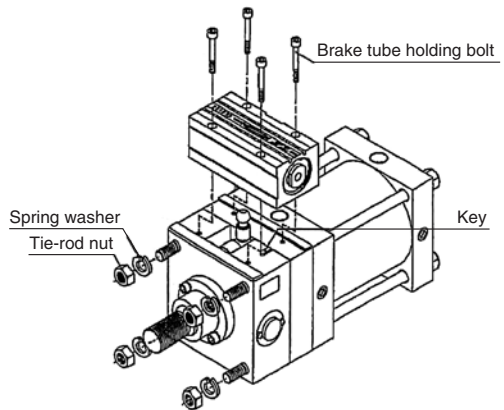

⚠ Caution

Apply 0.08 MPa or more of air pressure to the cylinder port before installing the equipment for checking the operation. Make sure that the manual release bolts are removed before installing the equipment.

Series REAS Replacement Procedure of Seal ①

1. Maintenance

As for sine rodless cylinders, the cushion ring and seal are assembled to provide the optimum cushioning effect.

Therefore, they should be returned to the factory for maintenance.

If you disassemble them by necessity, please note the following points.

- 1-1. To remove external slider or piston slider from cylinder tube, holding force must be released by shifting positions of external slider and slider piston forcibly. Removing those without doing so, respective magnets call each other directly and may become impossible to separate.
- 1-2. Upon completing above works to separate respective sliders, by loosening hexagon head cap screw (at Ipate A side,) remove cylinder tube and plate A from guide rod A and B. (While replacing works (of packing, so on), other parts should not be disassembled, disassembling other parts may cause to air leakage.)
- 1-3. Magnet assembly (piston slider and external slider) must not be disassembled. Disassembling this may cause to decrease of holding force and other defects.
- 1-4. When handle magnet assembly, watch on your arm should be put off not to get influence from strong magnetic field.

1-5. Thorough care should be taken for the magnet not to drop on the floor or knock against metal.

1-6. Make sure the external slider is in the correct direction. (REAS10 only).

Insert the external slider (slide block) and the piston slider to the cylinder tube. If the direction is incorrect (Fig. 2), turn the piston slider 180 degrees then insert. If the direction is not corrected, the specified holding force will not be realized.

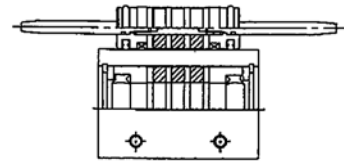

Fig. (1) Correct position

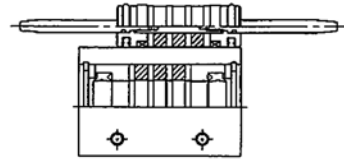

Fig. (2) Incorrect position

Series **REC** Replacement Procedure of Seal ①

1. Disassembly and Reassembly of the Cylinder

A clean place is necessary to disassemble and reassemble the cylinder. Put a clean waste on a working place. For disassembly, hold width across flats of the head cover or rod cover by vice or by spanner or monkey spanner, and loose and remove the covers respectively.

2. Removal of the Seal

2-1. Rod seal

The rod seal A can be replaced with the cylinder mounted. On the other hand, the rod seal B should not be replaced by customer because of its difficulty in mounting works.

Use retaining ring pliers (tool for installing a basic internal retaining ring) to remove the retaining ring, and take the piston rod out from the rod cover with closing the ports of the rod cover by fingers. Then, the seal holder and rod seal A will appear and can be removed from the piston rod.

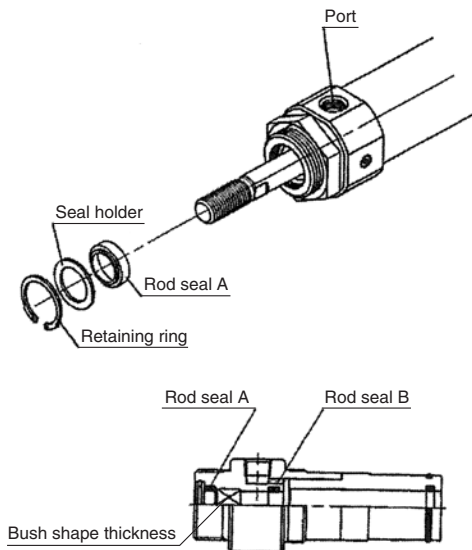

Fig. 1

2-2. Piston seal

Wipe off grease around piston seal first to make removal easier.

Hold piston seal with one hand and push it into groove so that piston seal can be lifted off and pulled out without using a watchmakers screw driver. (Fig. 2)

2-3. Tube gasket

Remove the tube gasket with the watchmakers screw driver or the like. (Be careful not to damage the surrounding parts of the tube gasket.)

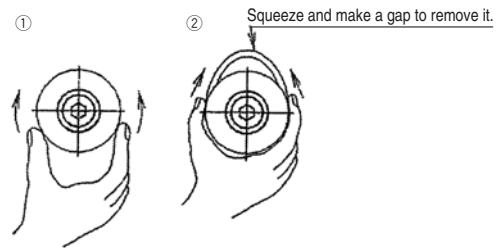

Fig. 2 Removal of piston seal

3. Application of Grease

Use lithium soap base grease equivalent to JIS class 2. You may also order our grease package (GR-S-010 for 10 g and GR-S-020 for 20 g).

3-1. Rod seal

Apply grease thin around the internal and external faces of the new seal for replacement. This is for smooth mounting of the rod seal to the cover and firm fitting between them. Also, the grease is required for the seal groove.

3-2. Piston seal

Apply grease thin and evenly around the internal and external faces of the piston seal for smooth mounting to the piston.

3-3. Tube gasket

Apply grease thin to the tube gasket to prevent it from coming off from the cylinder when assembling.

3-4. Other parts of cylinder

The parts of the cylinder shown in Fig. 3 also require grease to be applied. The amount shall be as specified in Table 1 for one cylinder with 100 stroke. You can consider the amount scooped by index finger to be approx. 3 g. (Fig. 4)

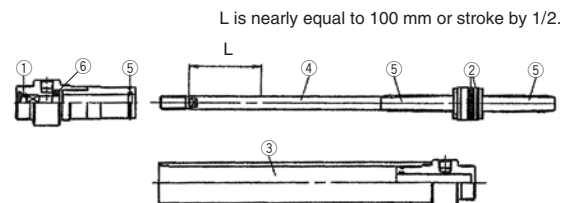

Fig. 3 Grease application points

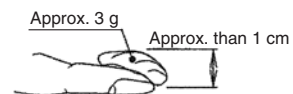

Fig. 4 Grease amount

Table 1 Grease application amount (g)

Stroke	ø20	ø25	ø32	ø40	Applying position
100 st	2	3	3	3 to 4	①②③④⑤⑥
50 st added	0.5	0.5	0.5	1	③④

4. Mounting of Seal

4-1. Rod seal

Mount the rod seal with care for direction. When passing the rod seal through the threaded part at the piston rod end and width across flat, press the rod seal slowly and gradually with rotating. And then, mount it to the housing of the rod cover firmly.

After that, mount the seal holder and retaining ring.

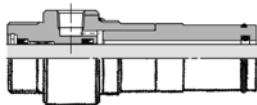

Fig. 5

4-2. Piston seal

Mount the piston seal and rub grease into the inside and the external face of the seal groove as shown in Fig. 6.

4-3. Tube gasket

Mount the tube gasket, apply grease slightly and mount to the head and rod covers.

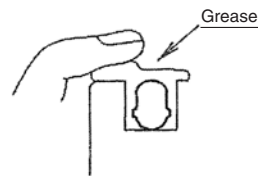

Fig. 6

That is all for the replacement of seals. After they are assembled, check if the cylinder operates smoothly by hand and there is no air leakage as the last step.

Series RHC Replacement Procedure of Seal ①

1. Replacement Procedure of Seal

Seal for cylinder should be disassembled and reassembled on the clean bench without metal chips and dust. Attached metal chips and dust will cause air leakage. Pay great attention to the operation to prevent air leakage.

1-1. Removal of mounting nut and bracket

Bracket such as foot and flange are fixed with nut. Loosen nut to remove bracket and mounting nut.

1-2. Removal of relief valve body holder

Since relief valve body holder is fixed with set screw, use hexagon wrench to loosen it. Relief valve body holder on cover side is slightly deformed due to screw. When relief valve body holder is removed from cover, remove it as rotating.



Picture 1: R/C side



Picture 2: H/C side

1-3. Removal of rod cover

When cylinder cover is removed after relief valve body holders on both rod and head cover side removed, fix head cover with vice and loosen screwed-in rod cover with spanner or monkey wrench.

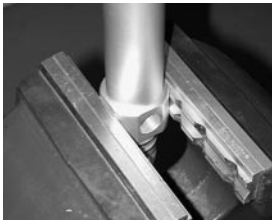

Picture 3: Fixed (H/C side)



Picture 4: R/C side

1-4. Removal of piston rod assembly

Extract piston rod assembly from tube as rotating it after rod cover is removed,

1-5. Removal of head cover

Loosen screwed-in tube as rotating it with pipe wrench leaving head cover fixed with vice. Pay great attention to the operation to prevent inside of tube from deformation.



Picture 5: H/C side

1-6. Removal of rod seal

Since rod seal is mounted on the cover part where groove is machined, remove it with watchmakers screw driver.

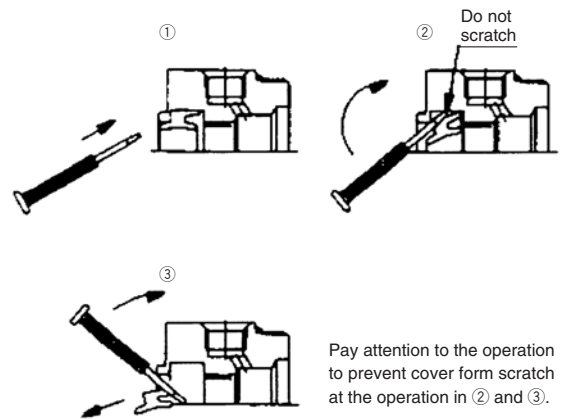

1-7. Removal of piston seal

Wipe off grease around piston seal to remove it easily, then remove it in accordance with the procedure stated below.

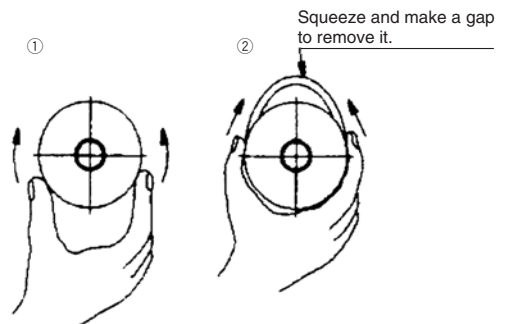

1-8. Replacement of wearing

When wearing is wore-out, remove and replace it with watchmakers screw driver.

Series RHC Replacement Procedure of Seal ②

1-9. Removal of cushion seal

Since cushion seal is mounted on the parts of rod and head cover where groove is machined, remove it carefully with watchmakers screw driver with the same operation for rod seal.

1-10. Each O-ring

Remove each part just in the case that there are flaws on surface of O-ring. Use same operation as piston seal for the small O-ring which mounted on the groove. Put small amount of grease.

1-11. Installation of rod seal

Install rod seal with correct direction after applying grease on whole part. Check if there is no deformation on seal, and if so, set it correctly with finger.

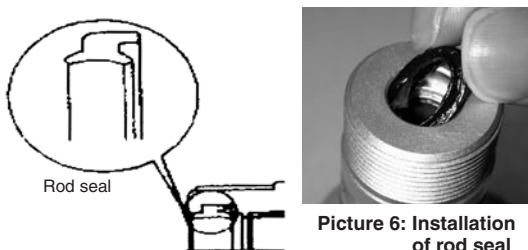

Picture 6: Installation of rod seal

1-12. Installation of cushion seal

Install cushion seal with correct direction after applying grease on whole part. Check if there is no deformation on seal, and if so, set it correctly with finger.

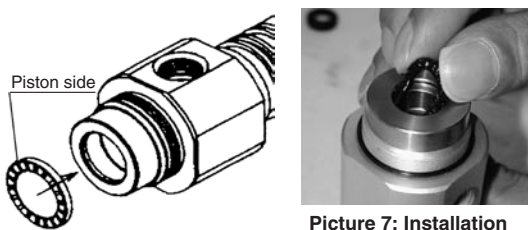

Picture 7: Installation cushion seal

1-13. Installation of piston seal

Install piston seal by expanding it to mounting groove after applying grease on whole part. Then, put grease to outside of piston like below diagram.

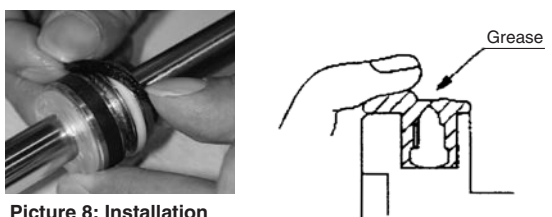

Picture 8: Installation of piston seal

1-14. Grease for piston rod assembly

Spread grease thinly and equally to pointed part stated below.

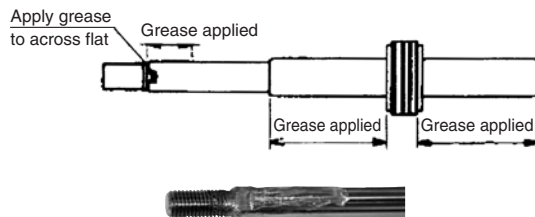

Picture 9: Grease applied piston rod assembly

1-15. Preliminary tightening of tube and cover

Prepare assembly by screwing head cover in tube with hand.

1-16. Grease for sliding portion (I.D.) of tube

Apply grease inside of cylinder tube. Put approx. 1cm (3 g) of grease on finger as standard and apply it to the range, which is equivalent length to cylinder I.D. equally.

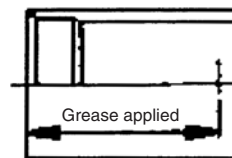

1-17. Insertion of piston rod assembly

Insert piston rod assembly to the assembly in step 1-16. Pay great attention to the operation to protect piston seal from flaws by screw at the end of tube.

1-18. Preliminary tightening of rod cover

Screw-in rod cover to the assembly assembled up to 3-17 with hand. Pay great attention to operation to protect rod seal from flaws by screws on the end of tube.

1-19. Final tightening of cover

Fix head cover with vice and screw-in rod cover with spanner and monkey wrench with the same procedure at disassembly. Tight additionally approx. 1-2° as standard considering the relation of ports between rod cover and head cover before disassembly.

1-20. Installation of relief valve body

Install relief valve body on cover. Install it as rotating until it touch's to the end of cover as facing C chamfer to outside.

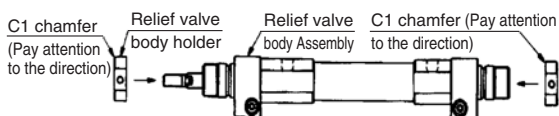

Actuators

Modular F.R.L.
Pressure Control Equipment

Air Preparation
Equipment

Industrial Filters

Replacement
Procedure

Actuators

Modular F.R.L.
Pressure Control Equipment

Industrial Filters

Series *RHC* Replacement Procedure of Seal 3

1-21. Relief valve fixing

Fix hexagon socket set screw with hexagon wrench.
Refer to the following table for tightening torque.

Table 3, Tightening torque (N·m)

Model	Tightening torque
RHC*20	1.5 ± 10%
RHC*25	1.5 ± 10%
RHC*32	2.6 ± 10%
RHC*40	2.6 ± 10%

1-22. Check before cylinder installation

Perform trial operation with min. operating pressure of 0.05 MPa before mounting cylinder to check if each part is not loosened or if there is no air leakage, then check same things at max. operating pressure of 1.0 MPa. After checking no failure on parts, install cylinder.

1. Replaceable Seal

1-1. The seals shown on the below figure are replaceable.

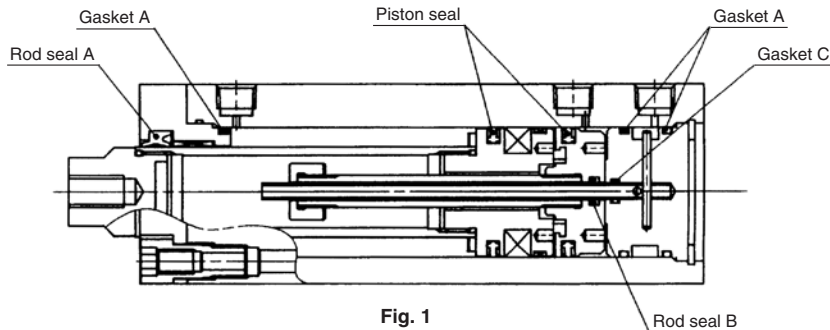

Fig. 1

2. Disassembly of the Cylinder

⚠ Caution

Cylinder needs to be disassembled/assembled at clean environment. Use a clean cloth. Before disassembly, eliminate the dirt on the outer surface so that foreign material does not enter the cylinder or the guide.

2-1. Removing rod cover

Loose the fitting bolts, and remove the rod cover.

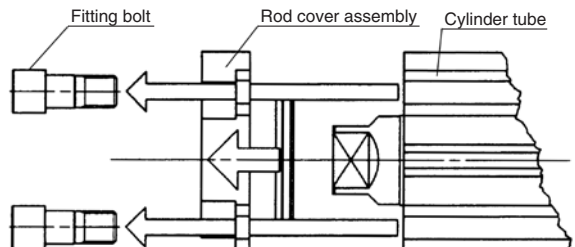

Fig. 2

2-2. Removal of components

Following the removal of a retaining ring, press the tube rod cover out from rod side, and take it out from head side.

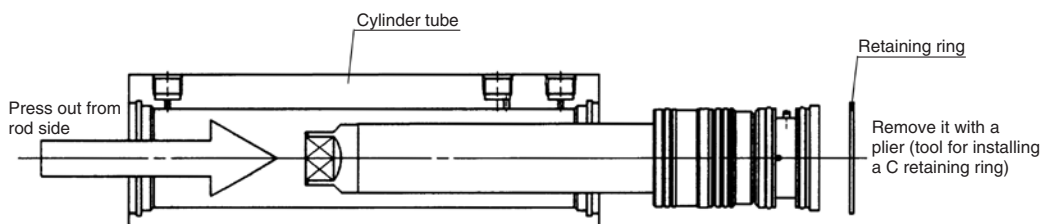

Fig. 3

⚠ Caution

Perform mounting and removal of the retaining ring with a proper plier (tool for installing a C retaining ring). There is a risk of causing damage for human body and peripheral equipment when a retaining ring is removed from the end of plier even if it is a proper plier. Supply air after checking the retaining ring is mounted at the retaining ring groove securely.

Series RZQ Replacement Procedure of Seal 2

2-3. Removal of head cover assembly

Take the head cover assembly out from the piston rod assembly.
(The piston rod assembly cannot be further disassembled.)

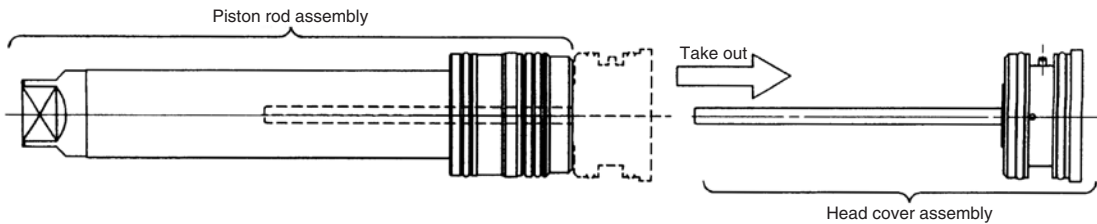

Fig. 4

2-4. Take the parallel pin out from the head cover, and remove the inner pipe.

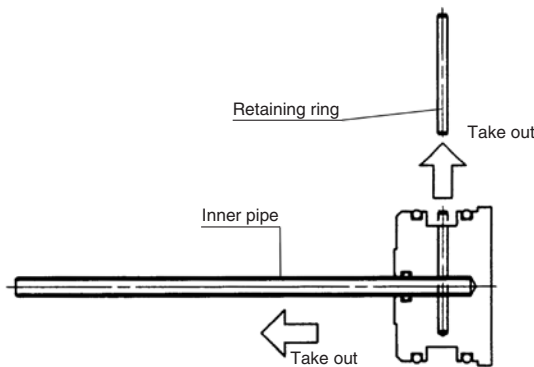

Fig. 5

3. Removal of the Seal

3-1. Removal of rod seal

Remove the seal by inserting a watchmakers screw driver from the front side of the rod cover. During this work, do not give a flaw on the seal groove at the rod cover.

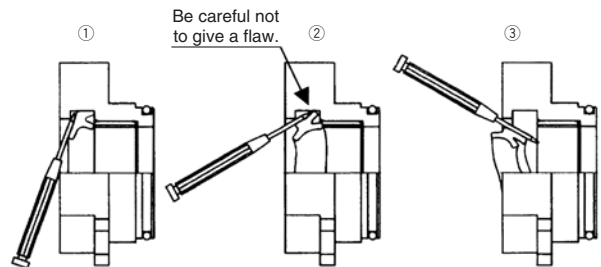

Fig. 6

3-2. Removal of piston seal

- Wipe out grease around the piston seal (it helps easy removal of a piston seal).
- As the piston seal groove is deep, remove the seal using a gap made by squeezing it, not using a precision driver.

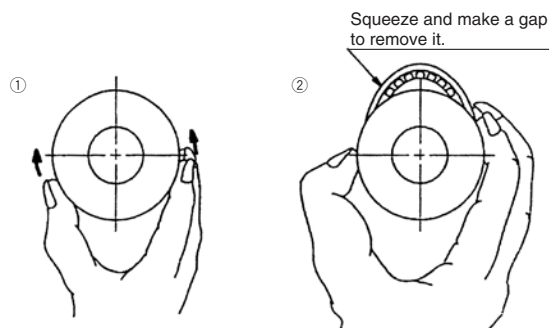

Fig. 7

Series *RZQ* Replacement Procedure of Seal 3

3-3. Removal of gasket

a. Gasket around rod cover and head cover

In the same way as the removal of piston seal, squeeze the gasket and make a gap to remove it.

b. Gasket inside head cover

In the same way as the removal of rod seal, insert a watchmakers screw driver to remove it. Be careful not to give a flaw on the seal groove at the rod cover.

4. Application of Grease

4-1. Rod seal and piston seal

Apply grease thinly and evenly to the seal for replacement. Fill grease into the groove.

4-2. Gasket

Apply grease thinly and evenly to the gasket for replacement.

4-3. Cylinder parts

Apply grease to each part.

Refer to "6. Assembling of Cylinder" for the parts to apply grease.



Fig. 8

5. Mounting of Seal

5-1. Rod seal

Mount the seal with care of its direction. Apply grease to the seal and the bushing evenly after mounting it as shown on Fig. 9.

Apply grease to the rod seal B with a precision driver.

5-2. Piston seal

Mount the seal without twisted. After mounting it, apply the grease to the seal and the seal groove as shown on Fig. 10.

5-3. Gasket

Fit it up with care of drop off.

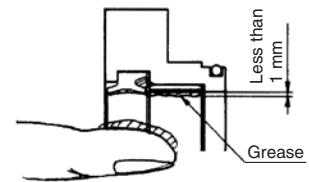

Fig. 9

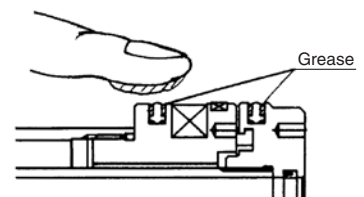

Fig. 10

6. Assembly of the Cylinder

6-1. Apply grease to insertion for head cover at the inner pipe.

6-2. Insert the inner pipe to the head cover. (Match the hole of head cover with the one of inner pipe.) Perform Inserting slowly and carefully so as not to catch the gasket.

6-3. Get the parallel pin through the head cover and the inner pipe.

6-4. Pull the inner pipe lightly to check it will not fall off from the head cover.

6-5. Apply grease to the inner pipe.

6-6. Insert the head cover assembly (inner pipe) to the piston rod assembly. Perform Inserting slowly and carefully so as not to catch the rod seal B.

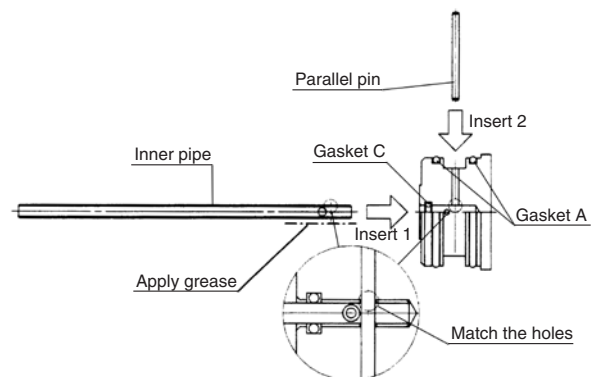

Fig. 11

Series RZQ Replacement Procedure of Seal 4

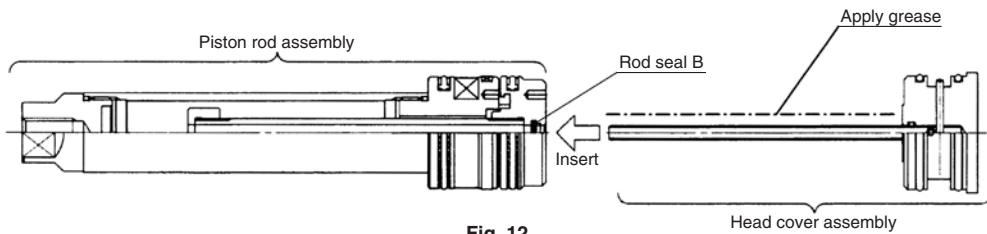

Fig. 12

- 6-7. Apply grease to inside of the cylinder tube and outside of the tube rod, the piston A, and the piston B.
- 6-8. Insert the piston rod assembly and head cover assembly to the cylinder tube. Perform Inserting slowly and carefully so as not to catch the piston seal and the gasket.
- 6-9. Mount a retaining ring on the cylinder tube to fix the head cover.

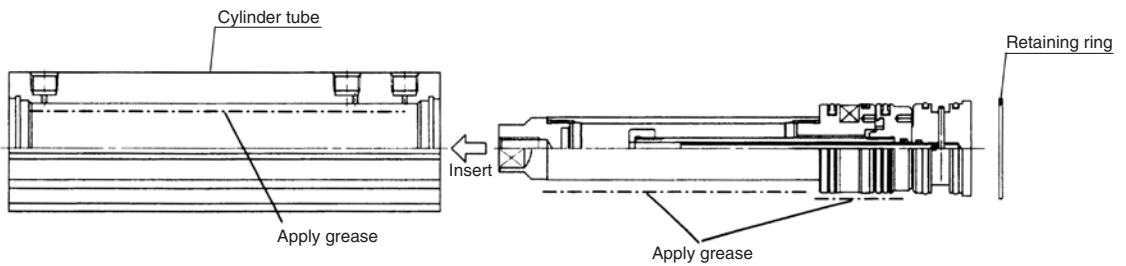

Fig. 13

- 6-10. Apply grease to the internal face of the bushing at the inside of the rod cover.
- 6-11. Insert the rod cover assembly to the cylinder tube. Mount the rod seal A slowly and carefully so as not to be caught.
- 6-12. Apply locking agent to the fitting bolt.
- 6-13. Tighten the fitting bolts at the cylinder tube to fix the rod cover. Refer to Table 1 for the tightening torque of the fitting bolts.

Table 1

Bore size (mm)	Nominal size	Tightening torque [N·m]
32	M8 x 0.75	6.2
40	M8 x 0.75	6.2
50	M10 x 0.75	15.6
63	M12 x 1.0	21.0

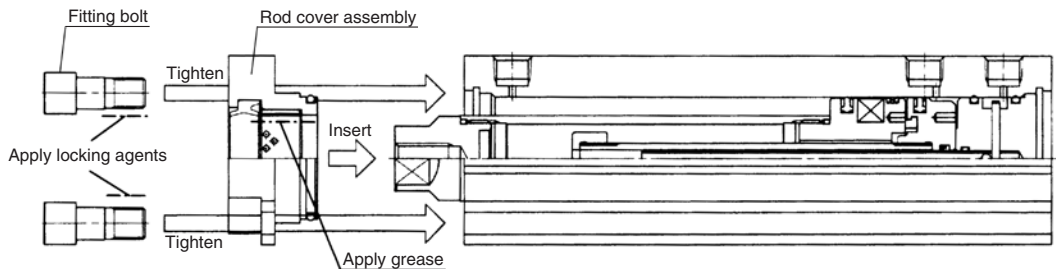

Fig. 14

After completing the assembly, confirm that there is not air leakage from the sealing parts, and also that it operates smoothly with the low operating pressure.

1. Disassembly of the Cylinder

1-1. Cleaning

Prior to disassembly, wipe off any dirt from the outside of the actuator. This will prevent the intrusion of dust and foreign materials during disassembly.

Take particular care on the surface of the piston rod.

1-2. Removal of arm

Remove the arm with rod point.

1-3. Removal of hexagon socket head cap screw [only $\phi 25$ or more]. (Fig. 1)

Remove the hexagon socket head cap screw (with washer or spring washer).

1-4. Removal of retaining ring (Fig. 2)

Remove with proper pliers (tool for basic internal retaining ring). Moreover, please note that the retaining ring comes off from pliers when detaching it, it files, and the human body and peripherals might be disadvantaged.

1-5. Disassembly

Install the bolt etc. in the point part of the piston rod, and pull it out with rod cover assembly and the key.

In that case, please note that neither the inside diameter of the tube nor the rod cover bearing are damaged.

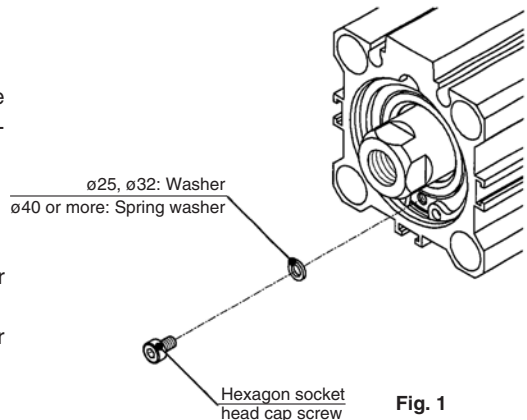

Fig. 1

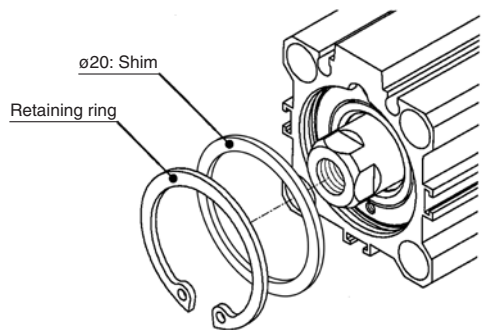

Fig. 2

2. Removal of the Seal

2-1. Removal of the coil scraper

Insert a precision driver etc. from front the rod cover assembly and prise the seal out. From front rod cover assembly and prise the coil scraper out.

Take care not to scratch or score the coil scraper groove in the rod cover assembly.

2-2. Removal of the rod seal

Insert a precision driver etc. from front the rod cover assembly and prise the seal out.

Take care not to scratch or score the seal groove in the rod cover assembly.

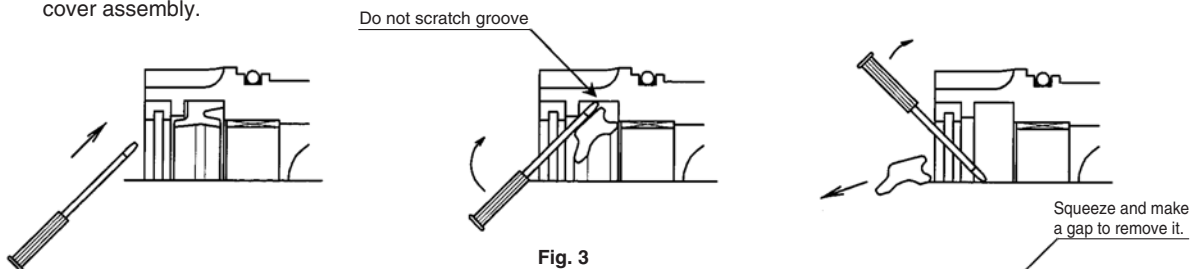

Fig. 3

2-3. Removal of the piston seal

As the piston seal groove is deep, remove the seal using a gap made by squeezing it, not using a precision driver.

2-4. Removal of the tube gasket

Squeeze the gasket and make a gap to remove it. (Refer to the right Fig. 4).

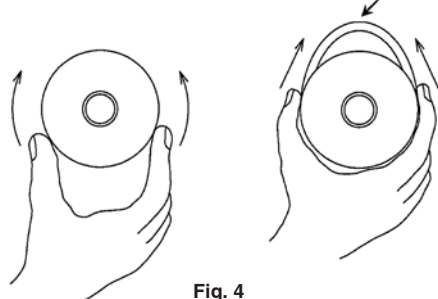

Fig. 4

3. Application of Grease

3-1. Grease spreading of rod seal and piston seal (Fig. 5)

There is thinly no irregularity and lithium system grease* is spread on all surroundings of rod seal and piston seal for the exchange.

*SMC recommendation grease: It is possible to arrange. (Refer to the operation manual.)

3-2. Grease spreading of tube gasket

There is thinly no irregularity and lithium system grease* is spread on the whole of the tube gasket for the exchange.

*SMC recommendation grease: It is possible to arrange. (Refer to the operation manual.)

3-3. Grease spreading of each part

There is thinly no irregularity and lithium system grease* is spread on a specified part of rod cover assembly, piston rod assembly and cylinder tube assembly.

*SMC recommendation grease: It is possible to arrange. (Refer to the operation manual.)

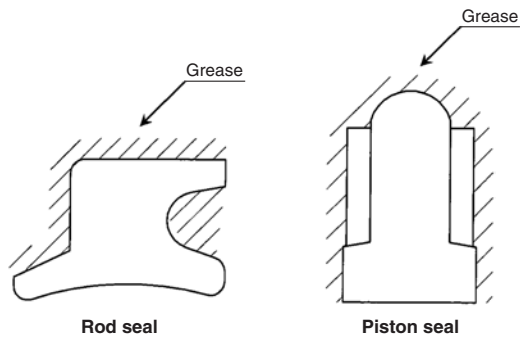

Fig. 5

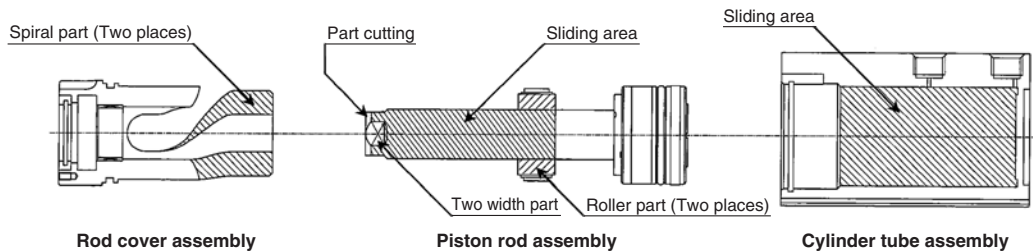

Fig. 6

4. Installation of Seal and Coil Scraper

4-1. Installation of rod seal and tube gasket (Fig. 7)

Install the direction of rod seal so as not to make a mistake. Install the tube gasket so as not to drop out of rod cover assembly.

After it installs it, there is no irregularity and lithium system grease* is spread on rod seal and the bearing.

*SMC recommendation grease: It is possible to arrange. (Refer to the operation manual.)

4-2. Installation of coil scraper

Install coil scraper for the exchange in the coil scraper ditch surely.

4-3. Installation of piston seal (Fig. 8)

Install it so that piston seal should not twist.

Spread it to rub lithium system grease* into between piston seal outer part and the ditch after it installs it.

*SMC recommendation grease: It is possible to arrange. (Refer to the operation manual.)

4-4. Installation of tube gasket

Please note the dropout, and install it.

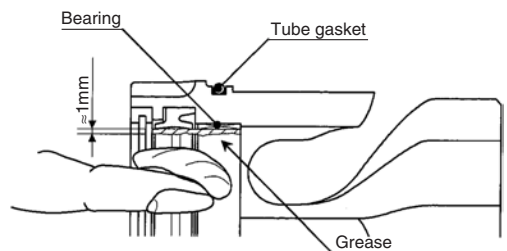

Fig. 7

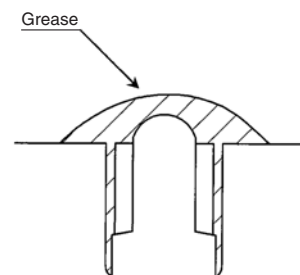

Fig. 8

5. Assembly of the Cylinder

5-1. Insertion of rod cover assembly (Fig. 9)

Insert it politely slowly so as not to damage rod seal in corner part piston rod assembly.

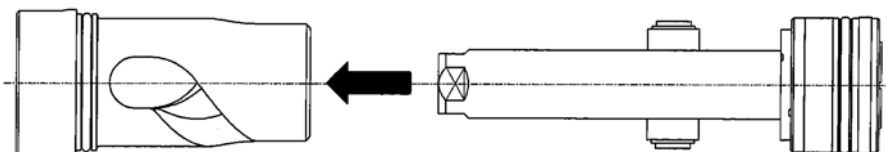

Fig. 9

5-2. Insertion of piston rod assembly (Fig. 10)

Insert it politely slowly to damage neither piston seal nor the tube gasket in corner part cylinder tube assembly.

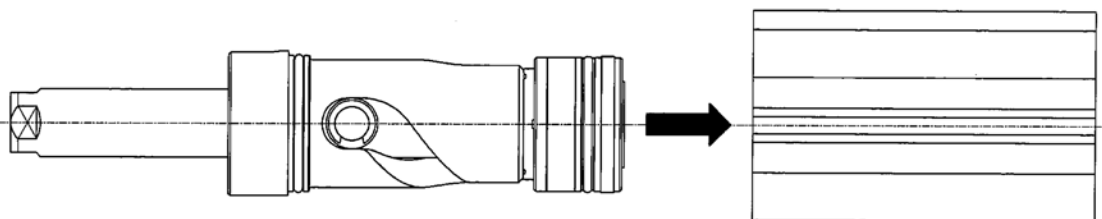

Fig. 10

5-3. Installation of key and retaining ring (Fig. 11)

Insert the key in the key ditch, and install the retaining ring with proper pliers (tool for basic internal retaining ring).

In that case, install the direction of the retaining ring so as not to make a mistake.

Because the retaining ring comes off from pliers when it installs it, it flies, and the human body and peripherals might be disadvantaged. Please note it.

Moreover, please confirm whether in the retaining ring ditch surely.

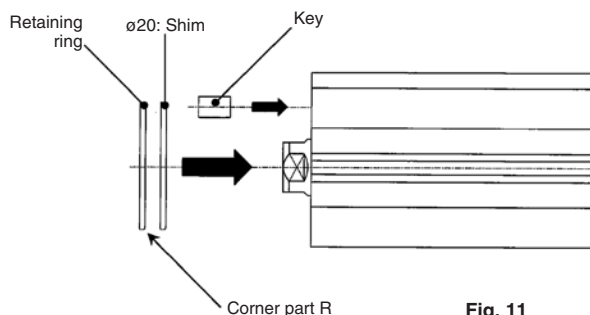

Fig. 11

5-4. Installation of hexagon socket head cap screw [only ø25 or more] (Fig. 12)

After cleaning the adhesive from the hexagon socket head cap screw and the rod cover assembly with alcohol etc., apply the tightening adhesive to the screw holes of the rod cover assembly (SMC recommended adhesive: Loctite Corp. 242 [Blue]) in order not to loose. Spread the adhesive (SMC recommendation adhesive: Loctite Corp. 242 [Blue]) for loose stop on screw hole part rod cover assembly.

Tighten with the hexagon socket head cap screw (*ø25, ø32: with washer/ø40 or more: with spring washer).

Please confirm whether the adhesive has overflowed after it concludes it.

Wipe an extra adhesive off when overflowing.

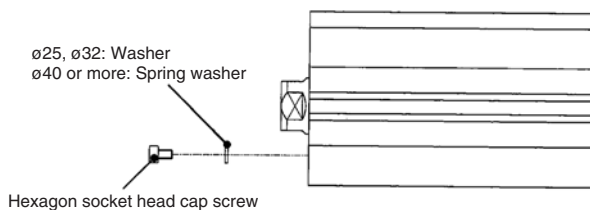

Fig. 12

Tightening torque

Bore size	Size of screw	Tightening torque (N·m)
ø25, ø32	M2.5 x 0.45	0.36 ± 10% (0.324 to 0.396)
ø40, ø50, ø63	M3 x 0.5	0.63 ± 10% (0.570 to 0.690)

5-5. Assembly confirmation

Please confirm whether not to cause the air leakage from the packing seal or to operate by the minimum operating pressure smoothly.

⚠ Caution

1. Confirm air is not supplied for the cylinder before disassembly and reassembly.

2. Never disassemble lock unit [For only CLKQG/CLKQP series]

The lock unit is equipped with heavy duty spring and may cause danger if disassembled.

Also, if it is reassembled incorrectly, the locking performance is impaired and desired function become unavailable.

For these reasons, the disassembly of lock unit at customer's site is prohibited strictly.

(If disassembly or replacement of a part is required absolutely, contact SMC.)

1. Removal of Spatter

a. Insert flat blade screwdriver into the groove of cover and set up the cover straight toward direction marked with arrows by the driver. Then the cover is opened.

* If excessive force is given to do this, the cover may be damaged.

b. Collect the spatter inside the groove.

c. Push the cover unit it snaps.

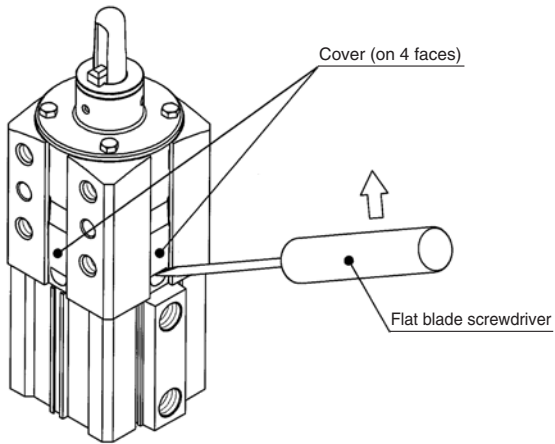

2. Replacement of Guide Pin and Clamp Arm

The clamping position height: For the LOW type

1. Disassembly of clamping part

a. Cleaning of appearance

Wipe off the dirt of appearance to prevent intrusion of dust and foreign materials during disassembly.

b. Removal of guide pin assembly.

Adjust the position of the clamp arm to the unclamping side, detach the hexagon socket set screw (3 pcs.), and guide pin assembly from guide tube.

Detach the parallel pin which does a positional match of guide tube and guide pin assembly.

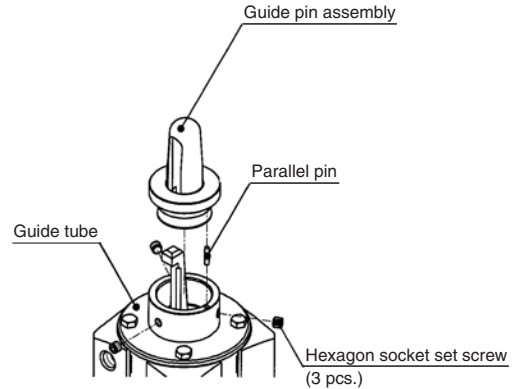

c. Removal of clamp arm

1) Detach the hexagon head bolt (4 pcs.), and detach the guide tube from the body.

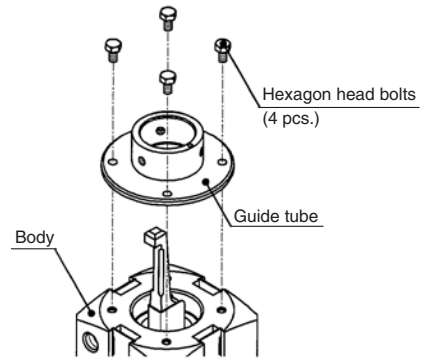

2) Insert a flat blade screwdriver or similar object into the cover groove and open. Then detach the cover (4 pcs.).

Detach pin A from the body side hole.

Pay attention to cut neither the hand nor the finger, etc. when you detach the cover.

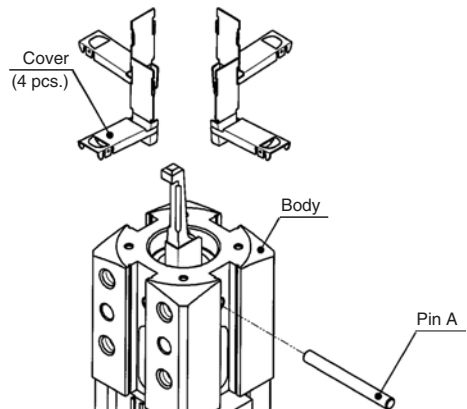

Series CKQG/CKQP Replacement Procedure of Seal 2

- 3) Loosen the hexagon socket head cap screw (4 pcs.) the base cylinder, and detach the body from the base cylinder.

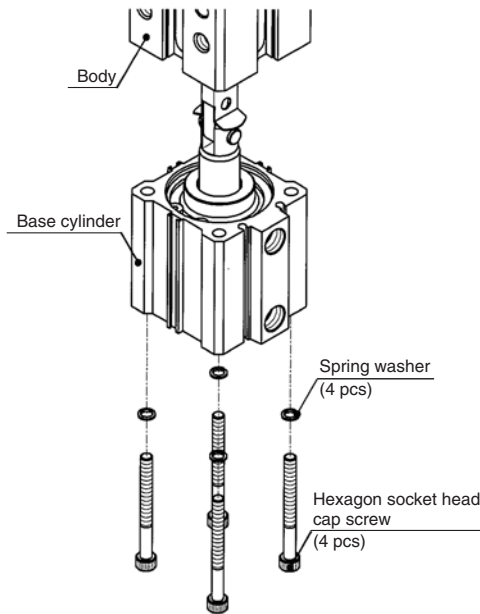

- 4) Extract the cotter pin, detach pin B, and detach the clamp arm (The spatter cover also together).

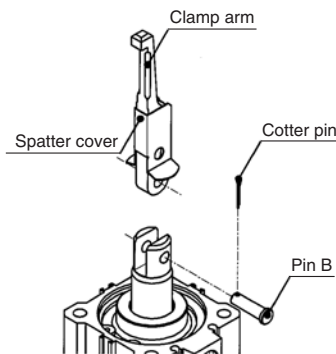

2. Reassembly of clamping part

a. Check of part no.

Check the number printed on clamp arm and guide pin assembly with reference to the following table.

	Printed no.	
	Guide pin assembly	Clamp arm
Applicable combination	125, 127, 128, 129, 130	13
	145, 147, 148, 149, 150	15-16
	155, 157, 158, 159, 160	15-16
	175, 177, 178, 179, 180	18
	195, 197, 198, 199, 200	20
	245, 247, 248, 249, 250	25
	295, 297, 298, 299, 300	30

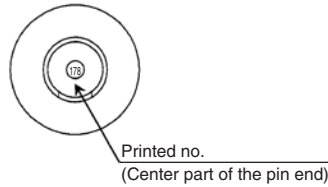

Guide pin assembly

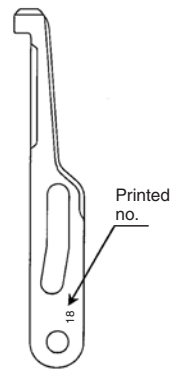

Clamp arm

b. Mounting of clamp arm

- 1) There is thinly no irregularity and lithium system grease is spread on the slash part of the clamp arm for the exchange (both sides). Moreover, there is no irregularity and lithium system grease is spread on the pin hole part and the cam ditch part of the clamping arm a lot (Grease can collect).

Install the spatter cover (The direction is noted) in the clamping arm.

In that case, install it so that the pin hole of the spatter cover and the cam groove of the clamp arm are visible.

Grease application amount (standard)

Both sides of clamping arm	≈ 0.05 g
Clamp arm pin hole part	≈ 0.10 g
Clamp arm cam ditch part	≈ 0.50 g

- 2) There is thinly no irregularity and lithium system grease is spread on the slash part in pin B and the piston rod slit part (both sides).

Moreover, there is no irregularity and lithium system grease is spread on the piston rod pin hole part a lot (Grease can collect).

Do not damage the finger etc. for the acute angle when you spread grease on the piston rod slit part.

Grease application amount (standard)

Pin B	≈ 0.05 g
Piston rod slit part	≈ 0.05 g
Piston rod slit part	≈ 0.10 g

- 3) Insert the clamp arm (with spatter cover) in the piston rod slit part and insert pin B.

Insert the cotter pin for the exchange through the hole for the cotter pin of pin B, and bend the point with the needle rose pliers.

- 4) Rotate the clamp arm, and rotate it so that the A-D installation position may squarely become direction of the fingernail.

(Rotate it while moving the piston rod up and down when it rotates.)

Actuators

Modular F.R.L.
Pressure Control Equipment

Air Preparation
Equipment

Industrial Filters

Replacement
Procedure

Actuators

Modular F.R.L.
Pressure Control Equipment

Industrial Filters

Series CKQG/CKQP Replacement Procedure of Seal 3

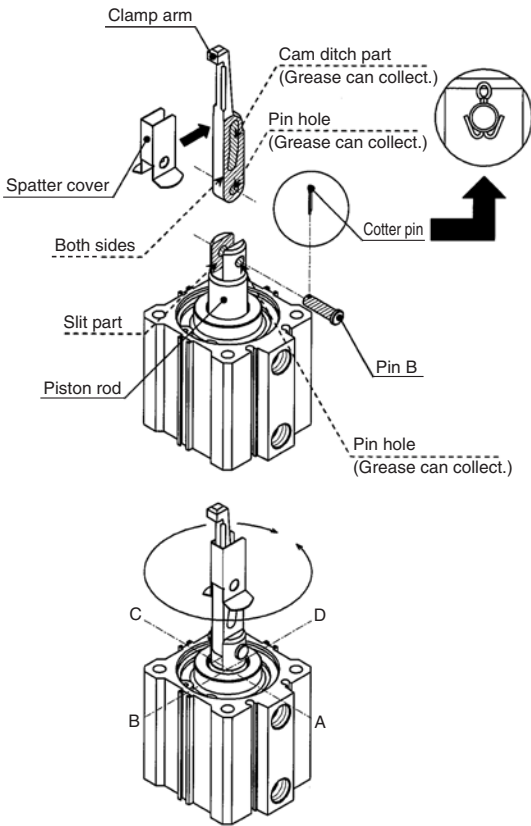

c. Mounting of guide pin assembly

- Put into the state to draw out the piston rod, confirm the body installation side and the clamping arm fingernail position, and insert the body. There is thin irregularity and lithium system grease is spread on the slash part of pin A. There is no irregularity and lithium system grease is spread on the body side hole part (pin A insertion part) a lot (Grease can collect). Insert pin A from the body side hole through the spatter cover and the clamp arm (Refer to a detail chart).

Grease application amount (standard)

Pin A	≈ 0.05 g
Body side hole part	≈ 0.20 g

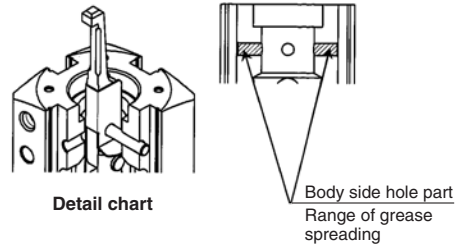
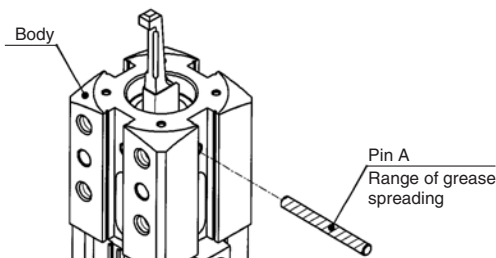

- Fasten, in order, the spring washer (4 pcs.) and the hexagon socket head cap screw (4 pcs.) from the head side of the base cylinder. Tightening torque: 4 to 6 (N·m)

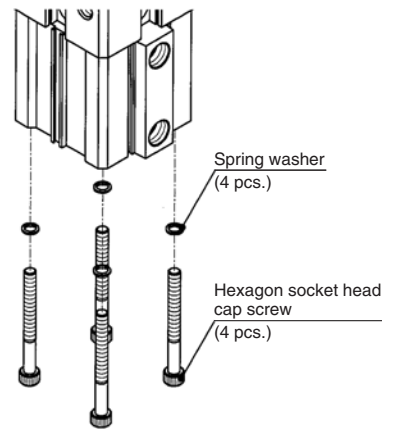

- Install the cover (4 pcs.) on the body. In that case, please note the direction of insertion.

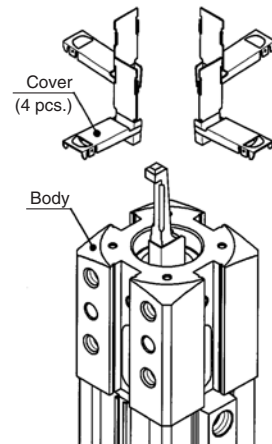

Series CKQG/CKQP Replacement Procedure of Seal 4

4) After cleaning the adhesive from the hexagon head bolts (4 pcs.) and the body with alcohol etc., apply the tightening adhesive to the screw holes of the body (SMC recommended adhesive: Loctite Corp. 242 [Blue]) in order not to loose. Please install the guide tube in the body with the hexagon head bolt (4 pcs.).

In that case, install it so the guide tube pin hole is on the right side of the clamp arm (detail chart).
Tightening torque: 1.5 to 1.8 (N·m)

Please confirm whether the adhesive has overflowed after concluding the hexagon head bolt (4 pcs.).
Wipe an extra adhesive off when overflowing.

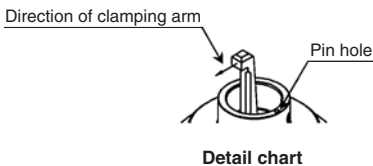
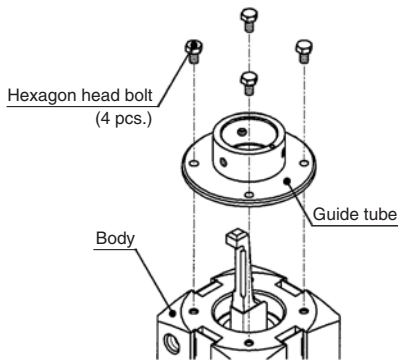

5) Insert the parallel pin for the exchange in the pin hole of guide pin assembly for the exchange, (when equipped with a shim, adhesive to secure the parallel pin to the guide pin assembly) suit to the position of the pin hole on the guide tube side, insert, and tighten with the hexagon socket set screw (3 pcs.: [green] with the adhesive).
Tightening torque: 4.86 to 5.94 (N·m)

However, when the adhesive color of the hexagon socket set screw (3 pcs.) is "red", or the "green" adhesive is stripped off from repeated replacements, completely remove the remaining adhesive from the thread of the hexagon socket set screw and the screw hole of the guide tube with alcohol. Then apply tightening adhesive (SMC recommendation: Loctite Corp. 242 [Blue]) to the hexagon socket set screw (3 pcs.).
Please confirm whether the adhesive has overflowed after it concludes it.

Wipe an extra adhesive off when overflowing.

For the with shim type, insert the shim between the guide pin assembly and the guide tube.
Install the order of shim referring to the following.
Please confirm shim does not dash out from the guide tube outer after assemble.

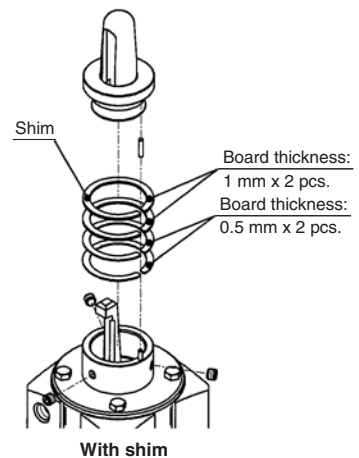
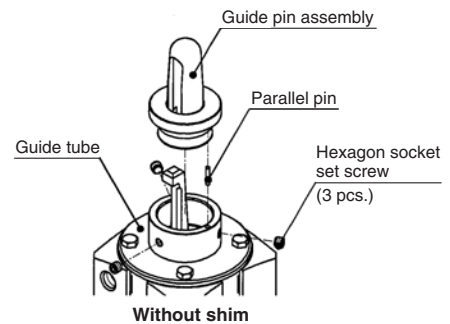

Actuators

Modular F.R.L.
Pressure Control Equipment

Air Preparation
Equipment

Industrial Filters

Replacement
Procedure

Actuators

Modular F.R.L.
Pressure Control Equipment

Industrial Filters

The Clamping Position Height: For HIGH

1. Disassembly of clamping part

a. Cleaning of appearance

Wipe off the dirt of appearance to prevent intrusion of dust and foreign materials during disassembly.

b. Removal of guide pin assembly

Adjust the position of the clamp arm to the unclamping side, detach the hexagon socket set screw (3 pcs.), and guide pin assembly from the guide tube. Detach the parallel pin which does a positional match of guide tube and guide pin assembly.

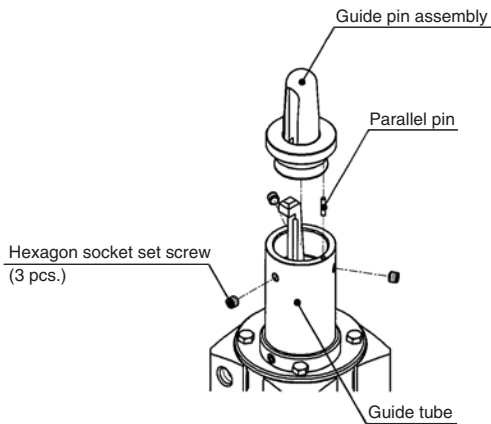

c. Removal of clamp arm

1) Detach the hexagon socket set screw, and detach the ring from the guide tube.

Detach pin A from the guide tube side hole.

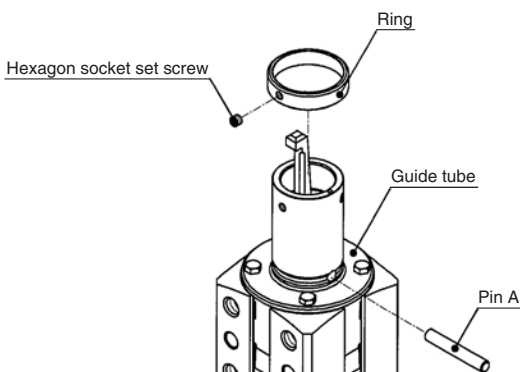

2) Detach the hexagon head bolt (4 pcs.), and detach the guide tube and the spatter cover from the body.

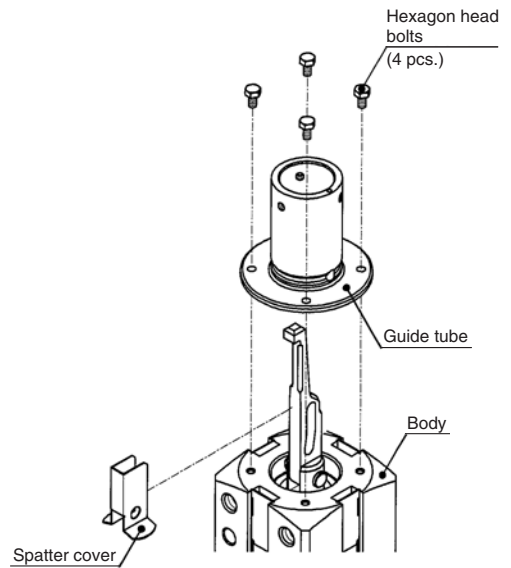

3) Insert a flat blade screwdriver or similar object into the cover groove and open. Then detach the cover (4 pcs.).

Pay attention to cut neither the hand nor the finger, etc. when you detach the cover.

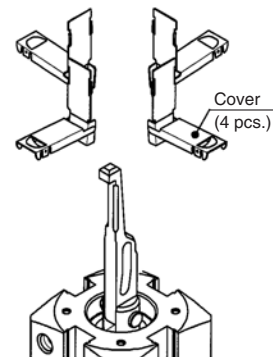

Series CKQG/CKQP Replacement Procedure of Seal 6

- 4) Loosen the hexagon socket head cap screw (4 pcs.) of the base cylinder, and detach the body from the base cylinder.

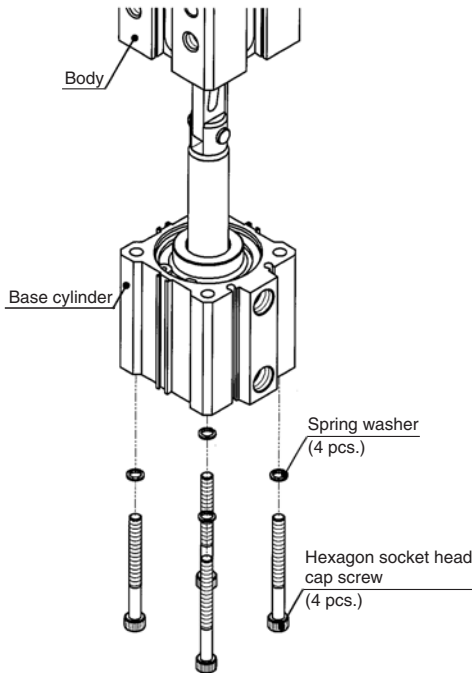

- 5) Extract the cotter pin, detach pin B, and detach the clamp arm.

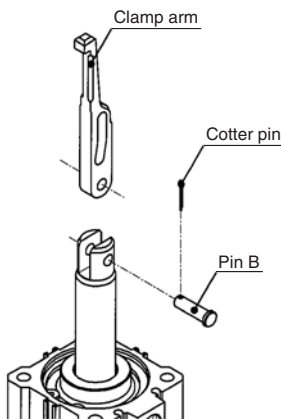

2. Reassembly of clamping part

a. Check of part no.

Check the number printed on clamp arm and guide pin assembly with reference to the following table.

	Printed no.	
	Guide pin assembly	Clamp arm
Applicable combination	125, 127, 128, 129, 130	13
	145, 147, 148, 149, 150	15-16
	155, 157, 158, 159, 160	15-16
	175, 177, 178, 179, 180	18
	195, 197, 198, 199, 200	20
	245, 247, 248, 249, 250	25
	295, 297, 298, 299, 300	30

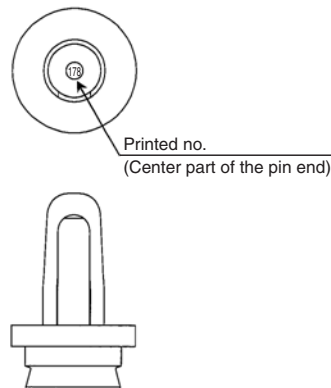

Guide pin assembly

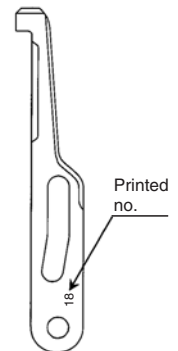

Clamp arm

b. Installation of clamp arm

- 1) There is thinly no irregularity and lithium system grease is spread on the slash part of the clamp arm for the exchange (both sides). Moreover, there is no irregularity and lithium system grease is spread on the pin hole part and the cam ditch part a lot (Grease can collect).

Grease application amount (standard)

Both sides of clamp arm	≈ 0.05 g
Clamp arm pin hole part	≈ 0.10 g
Clamp arm cam ditch part	≈ 0.50 g

- 2) There is thinly no irregularity and lithium system grease is spread on the slash part in pin B and the piston rod slit part (both sides). There is no irregularity and lithium system grease is spread on the piston rod pin hole part a lot (Grease can collect). Do not damage the finger etc. in the slit part for the acute angle when you spread grease on the piston rod slit part.

Grease application amount (standard)

Pin B	≈ 0.05 g
Piston rod slit part	≈ 0.05 g
Piston rod pin hole part	≈ 0.10 g

Series CKQG/CKQP Replacement Procedure of Seal 7

- 3) Insert the clamp arm in the piston rod slit part and insert pin B.

Insert the cotter pin for the exchange through the hole for the cotter pin of pin B, and bend the point with the radio pincers.

- 4) Rotate the clamp arm, and rotate it to become it at right angles with the A-D installation position and the direction of the fingernail.
(Rotate it while moving the piston rod and down when it rotates.)

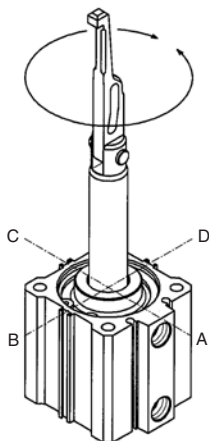
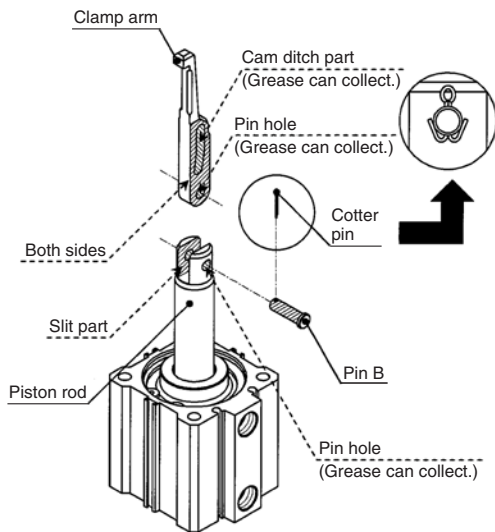

c. Mounting of guide pin assembly

- 1) Put into the state to draw out the piston rod, confirm the body installation side and the clamp arm fingernail position, and insert the body.
Fasten, in order, the spring washer (4 pcs.) and the hexagon socket head cap screw (4 pcs.) from the head side of the base cylinder.
Tightening torque: 4 to 6 (N·m)

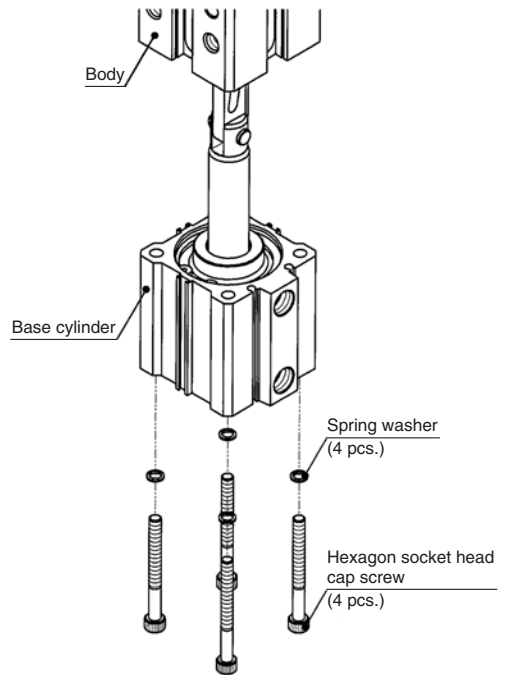

- 2) Install the cover (4 pcs.) on the body. In that case, please note the direction of insertion.

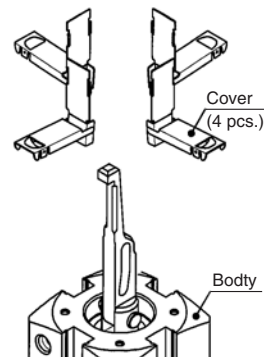

- 3) After cleaning the adhesive from the hexagon head bolts (4 pcs.) and the body with alcohol etc., apply the tightening adhesive to the screw holes of the body (SMC recommended adhesive: Loctite Corp. 262 [Red]) in order not to loose. Spread lithium system grease on the pin hole part of pin A and the guide tube.

Grease application amount (standard)

Pin A	≈ 0.05 g
Guide tube pin hole part	≈ 0.10 g

Series CKQG/CKQP Replacement Procedure of Seal 8

Install the spatter cover (The direction is noted) in the clamp arm.

In that case, install it so that the pin hole of the spatter cover and the cam groove of the clamp arm are visible.

Insert the guide tube in the body.

In that case, install it so the guide tube pin hole is on the right side of the clamp arm (detail chart).

Insert pin A from the guide tube side hole through the spatter cover and the clamp arm (Refer to detail chart 2).

Install it with the hexagon head bolt (4 pcs.) after inserting pin A. Tightening torque: 1.5 to 1.8 (N·m).

Please confirm whether the adhesive has overflowed after concluding the hexagon head bolt (4 pcs.).

Wipe an extra adhesive off when overflowing.

4) Insert the ring in the guide tube and install it with a hexagon socket set screw (with the adhesive [Green]).

Align the screw hole position of the ring to the same direction of the clamp arm claw and tighten.

(Refer to the figure below.)

Tightening torque: 4.86 to 5.94 (N·m)

However, when the adhesive color of the hexagon socket set screw is "red", or the "green" adhesive is stripped off from repeated replacements, completely remove the remaining adhesive from the thread of the hexagon socket set screw and the screw hole of the guide tube with alcohol. Then apply tightening adhesive (SMC recommendation: Loctite Corp. 242 [Blue]) to the hexagon socket set screw (3 pcs.).

Please confirm whether the adhesive has overflowed after it concludes it.

Wipe an extra adhesive off when overflowing.

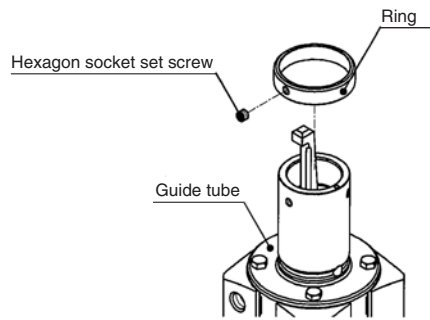
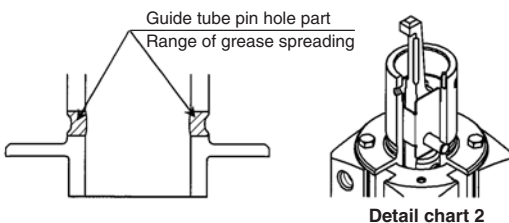
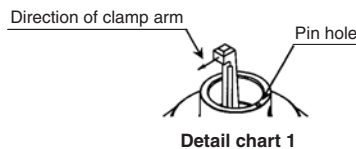
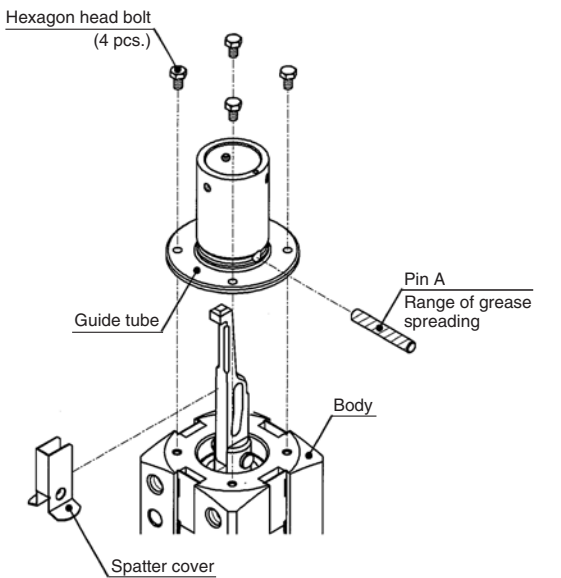

Actuators

Modular F.R.L.
Pressure Control Equipment

Air Preparation
Equipment

Industrial Filters

Replacement
Procedure

Actuators

Modular F.R.L.
Pressure Control Equipment

Industrial Filters

5) Insert the replacement parallel pin in the pin hole of the replacement guide assembly (when equipped with a shim, secure with adhesive on the parallel pin and the guide pin assembly), line up with the pin hole on the guide tube, insert, and tighten with the hexagon socket set screw (3 pcs.: with the adhesive [Green]).

Tightening torque: 4.86 to 5.94 (N·m)

However, when the adhesive color of the hexagon socket set screw (3 pcs.) is "red", or the "green" adhesive is stripped off from repeated replacements, completely remove the remaining adhesive from the thread of the hexagon socket set screw and the screw hole of the guide tube with alcohol. Then apply tightening adhesive (SMC recommendation: Loctite Corp. 242 [Blue]) to the hexagon socket set screw (3 pcs.).

Please confirm whether the adhesive has overflowed after it concludes it.

Wipe an extra adhesive off when overflowing.

For the with shim type, insert the shim between the guide pin assembly and the guide tube. Install the order of shim referring to the following. Please confirm shim does not dash out from the guide tube outer after assemble.

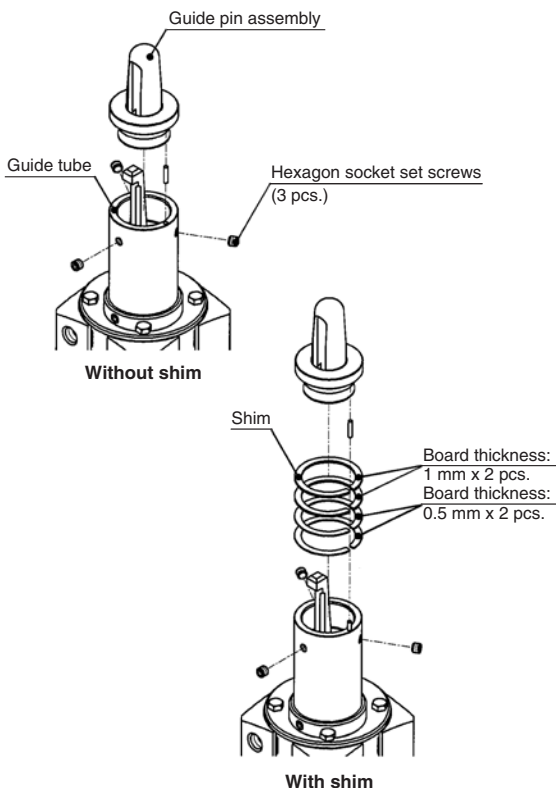

3. Replacement of Seal

(Only for Series CKQG/P because disassembly of CLKQG/P is unacceptable.)

3-1. Disassembly of base cylinder

a. Cleaning of appearance

Wipe off the dirt of appearance to prevent intrusion of dust and foreign materials during disassembly.

Intensively, pay attention to surface of piston rod and collar.

b. Removal of retaining ring

Use adequate pliers (tool for installing a basic internal ring).

And pay attention not to cause the retaining ring to pop out and damage the human body and peripheral equipments.

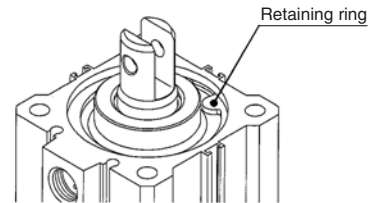

c. Disassembly

Take off the piston rod with collar assembly by pulling out the pin inserted into the hole on the end of piston rod and then remove the collar assembly from the piston rod assembly.

At the time, pay attention not to give any flaw on inner face of the tube and bearing of the collar assembly.

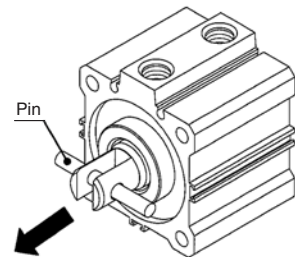

Series CKQG/CKQP Replacement Procedure of Seal 10

3-2. Removal of seal

a. Removal of rod seal

Remove by watchmakers screw driver inserted from the front of collar assembly.

Do not give any flaw on the groove of the collar assembly packing.

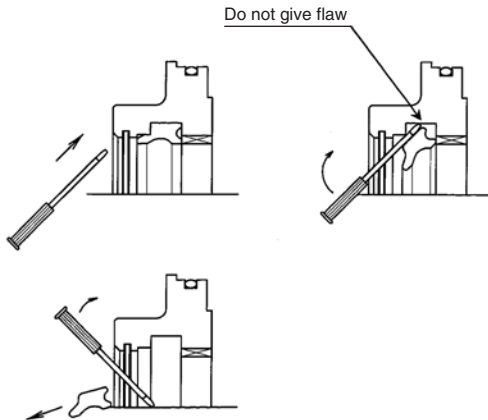

b. Removal of piston seal

As the piston seal groove is deep, remove the seal using a gap made by squeezing it, not using a precision driver.

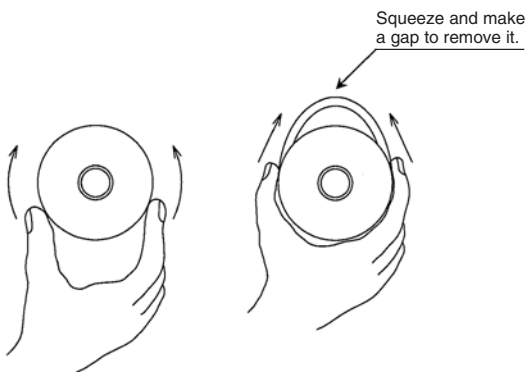

c. Removal of tube gasket

Push the packing gasket partially to make it come off and pull it out manually.

Squeeze the gasket and make a gap to remove it. (Refer to the above figure.)

3-3. Application of grease

a. Rod seal and piston seal

There is thinly no irregularity and lithium system grease is spread on all surroundings of rod seal and piston seal for the exchange.

Grease application amount (standard)

Rod seal	≈ 0.10 g
Piston seal	≈ 0.30 g

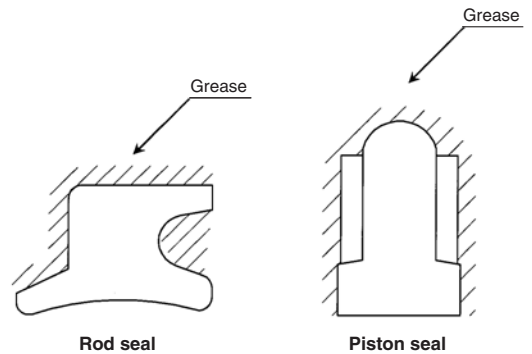

b. Tube gasket

There is thinly no irregularity and lithium system grease is spread on the whole of the tube gasket for the exchange.

Grease application amount (standard)

Tube gasket	≈ 0.15 g
-------------	----------

c. Each components of cylinder

There is thinly no irregularity and lithium system grease is spread on a specified part of piston rod assembly and cylinder tube assembly.

Grease application amount (standard)

Sliding part and taper of piston rod	L type	≈ 0.20 g
	H type	≈ 0.30 g
Sliding part of cylinder tube		≈ 0.40 g

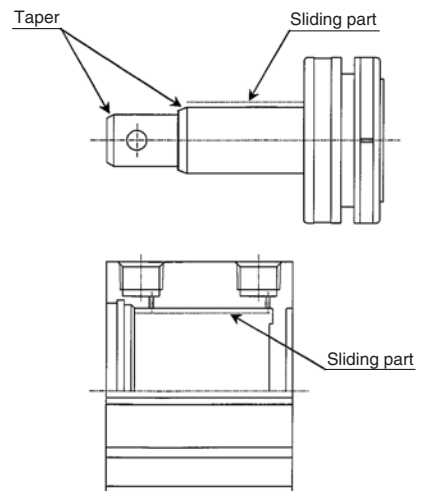

Series CKQG/CKQP Replacement Procedure of Seal 11

3-4. Mounting of seal

a. Mounting of rod seal

Mount the seal with attention to direction.
After installation, apply lithium type grease evenly onto the rod seal and bearing.

Grease application amount (standard)

Rod seal and bearing	≈ 0.25 g
----------------------	----------

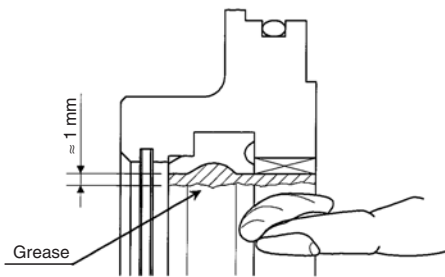

b. Mounting of piston seal

Mount the piston seal without twist.
Spread it to rub lithium system grease into between piston seal outer part and the ditch after it installs it.

Grease application amount (standard)

Piston packing outer part and ditch	≈ 0.70 g
-------------------------------------	----------

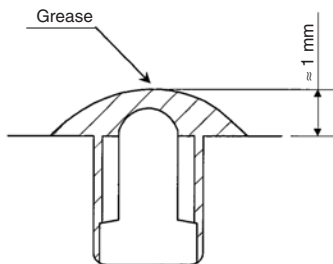

c. Mounting of tube gasket

Pay attention not to make the gasket come off.

3-5. Reassembly of cylinder

a. Insertion of piston rod assembly

Insert it politely slowly so as not to damage rod seal in corner part cylinder tube assembly.

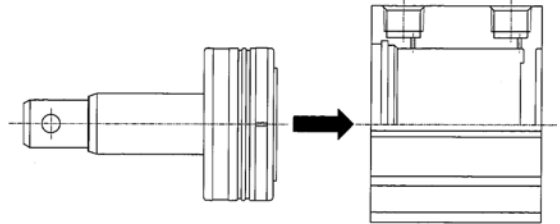

b. Insertion of color assembly

Damage neither rod packing nor the tube gasket in corner part piston rod assembly and cylinder tube assembly. Insert it politely slowly.

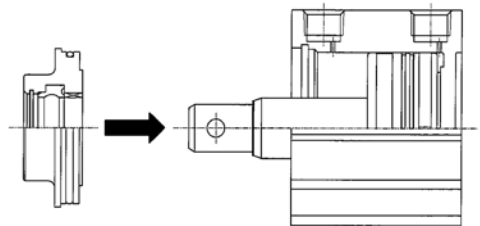

c. Mounting of retaining ring

Use adequate pliers (tool for installing a basic internal ring).
Mount the retaining ring with attention to direction.
And pay attention not to cause the retaining ring to pop out and damage the human body and peripheral equipments.
After mounting, confirm the retaining ring is secured firmly by the mating hole.

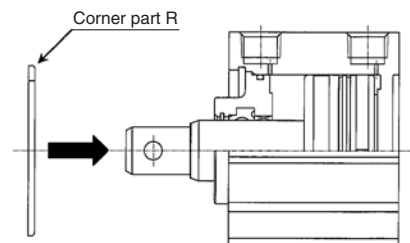

d. Check of reassembly condition

Confirm there is no air leakage from seal etc. and the cylinder can be moved smoothly at min. operating pressure.

1. Disassembly and Assembly of the cylinder

Disassemble and assemble the cylinder in a clean area. Perform on a clean cloth.

For disassembling, hold the flats of the tube cover gently in a vice and hold the flats of the rod cover with a spanner or monkey wrench to loosen and remove the rod cover. When reassembling, tighten 2 degrees more than the original position before disassembling.

2. Removal of the Seal

2-1. Rod seal

Tool: Watchmakers screw driver, etc.

Insert a precision screwdriver from the front side of the cover as shown in Figure 1.

At this time, exercise care not to damage the packing groove of the cover.

2-2. Piston seal

Wipe off grease around piston seal first to make removal easier.

Hold piston seal with one hand and push it into groove so that piston seal can be lifted off and pulled out without using a watchmakers screw driver. (Fig. 2)

2-3. Tube gasket

Remove the tube gasket with the watchmakers screw driver or the like.

3. Application of Grease

3-1. Rod seal

Thinly apply grease to the periphery of a new seal before replacement. Grease will help tight fitting to the cover.

Fill the seal groove with grease for smooth movement. (Fig. 3)

3-2. Piston seal

Apply grease thinly and evenly to the external and internal peripheries of the piston packing to ensure easy fitting to the piston.

3-3. Tube gasket

Thinly apply grease to the tube gasket. Grease will help prevention of dropping off during fitting the cylinder.

3-4. Cylinder parts

Apply grease to all points of cylinder parts as shown in Figure 4.

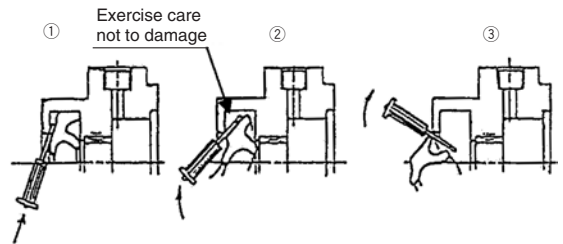

Fig. 1 Removal of rod seal

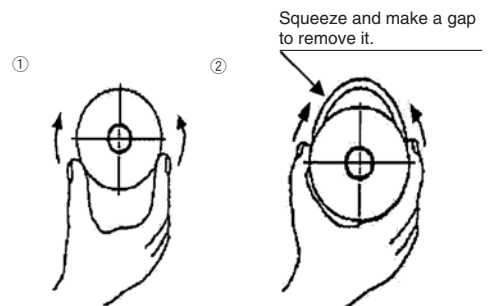

Fig. 2 Removal of piston seal

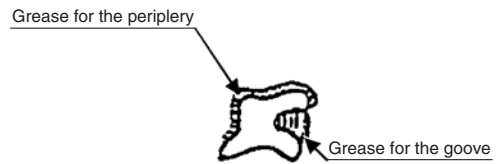

Fig. 3

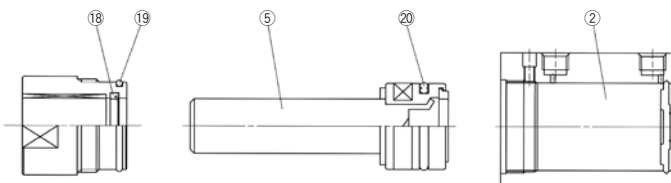

Fig. 4 Grease application points

4. Mounting of Seal

4-1. Rod seal

Mount the rod seal in the correct direction. After this, apply grease to the seal and the entire internal periphery of the bushing as shown in Figure 5. For small diameter cylinders, apply grease using the watchmakers screw driver.

4-2. Piston seal

After mounting the seal, apply grease to the inner and outer peripheries of the seal groove while rubbing it by finger as shown in Fig. 6.

4-3. Tube gasket

Mount the tube gasket on the cover.

After completion of installation, check the cylinder for smooth manual movement. Moreover, the procedure will be finished after checking a leakage from the seal.

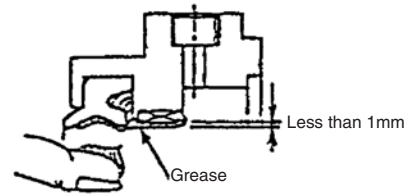

Fig. 5 Rod seal

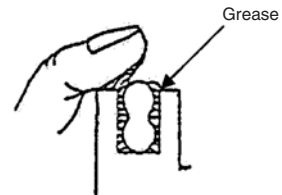

Fig. 6 Piston seal

5. Replacement Procedure of Shock Absorber

5-1. Loosen the hexagon socket head set screw (M3) at the piston rod by approximately one turn, and push down the lever. (See Fig. 7)

Tool: Hexagon wrench: Width across flats 1.5mm

Replacement Parts: Shock Absorber

Bore size (mm)	Kit no.
32	RB1007-X225
40-50	RB1407-X552

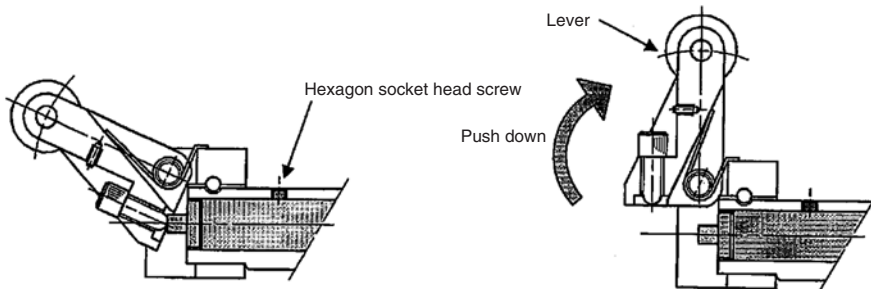

Fig. 7

5-2. While pushing down the lever, remove the shock absorber and replace it with a new shock absorber.

Tighten the hexagon socket set screw (M3 x 0.5) of the piston rod. Stop tightening around 1/4 turn after the set screw comes into contact with the shock absorber.

If it is tightened too much, it may cause damage to the hexagon socket set screw or a malfunction of the shock absorber.

Tightening torque: 0.29 N·m

Tool: Hexagon wrench: Width across flats 1.5mm

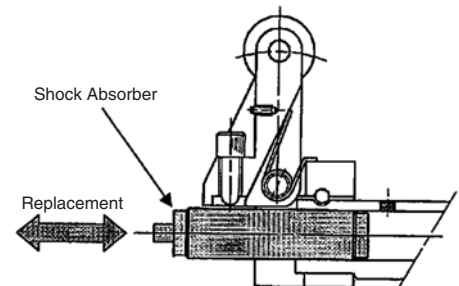

Fig. 8

1. Replacement Procedure of Seal

The piston seal, cylinder tube gasket, O-ring of the RSH/RS2H series can be replaced. The scraper of the RSH series can be replaced.

Contact SMC sales if it is necessary to replace parts other than those mentioned above.

⚠ Caution

When replacing seals, take care not to hurt your hand or finger on the corners of parts.

2. Disassembly/Reassembly

⚠ Caution

Disassemble and assemble the cylinder in a clean area. Perform on a clean cloth.

When disassembling the cylinder, loosen the hexagon socket head cap screws (ø20: 2pcs., ø32 to ø80: 4pcs.) with a hexagon wrench. Remove the rod cover and piston rod from the cylinder tube as Fig.1

When reassembling, apply locking adhesive on the hexagon socket head cap screws and tighten them.

- Hexagon socket head cap screw tightening torque
 - ø20: 3.0 N·m
 - ø32: 5.2 N·m
 - ø50: 12.5 N·m
 - ø63: 24.5 N·m
 - ø80: 42.0 N·m

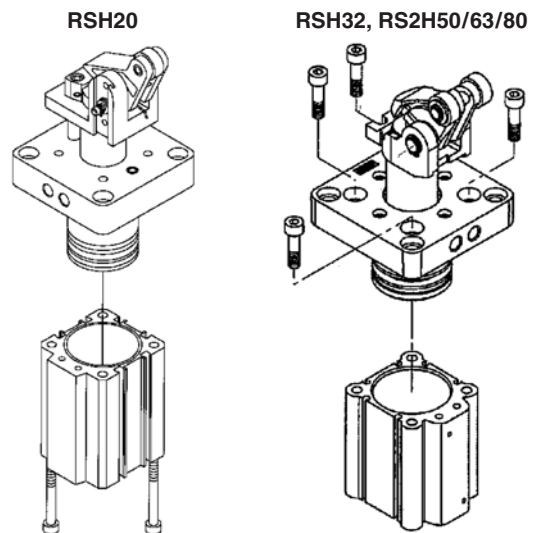

Fig. 1

3. Removal of Seal

3-1. Piston seal

Wipe off grease around piston seal first to make removal easier.

Hold piston seal with one hand and push it into groove so that piston seal can be lifted off and pulled out without using a watchmakers screw driver. (Fig. 2)

3-2. Tube gasket

Remove the tube gasket with the watchmakers screw driver or the like.

3-3. O-ring

Remove the tube gasket with the watchmakers screw driver or the like.

3-4. Scraper (Series RSH only)

Remove the scraper by inserting a watchmakers screw driver or the like. Take care not to damage the seal groove of the cover at this time.

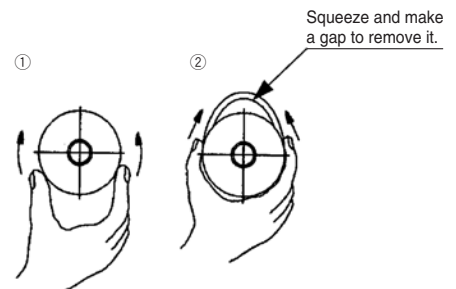

Fig. 2

4. Grease Application

Caution

Use our recommended grease.

Grease pack no.: GR-S-010 (10 g), GR-S-020 (20 g)

4-1. Piston seal (RSH, RS2H: No.37)

Lightly and evenly apply grease to the inner and outer circumferences for easier mounting on the piston.

4-2. Tube gasket (RSH: No.40, RS2H: No.39)

Lightly apply grease. This prevents its drop when assembling the cylinder.

4-3. O-ring (RSH: No.41, RS2H: No.40)

Lightly apply grease. This prevents its drop when assembling the cylinder.

4-4. Scraper (RSH: No.39)

Apply a little grease to the outer circumference of the new seal for replacement. This improves mounting and adhesion of the seal to the cover.

4-5. Cylinder component parts

Apply grease to each component parts of the cylinder in Figure 3.

RSH20/32

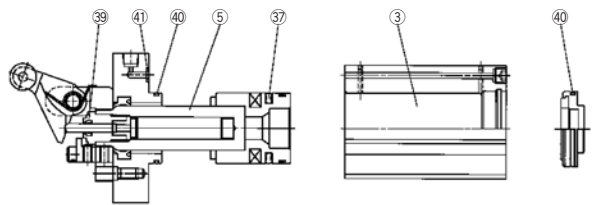

RS2H50/63/80

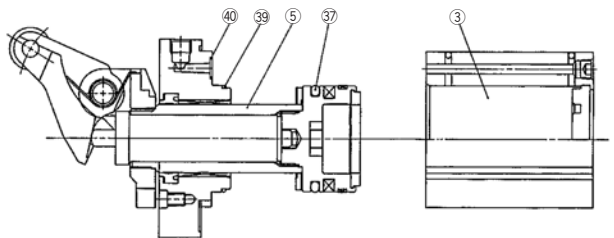

Fig. 3

5. Mounting of Seal

5-1. Piston seal

After mounting the seal, apply grease to the inner and outer peripheries of the seal groove while rubbing it by finger as shown in Fig. 4.

5-2. Tube gasket

Mounted to the cover. (For the RSH series, tube gasket is mounted to the bottom plate, too.)

5-3. O-ring

Apply O-ring to the cover.

5-4. Scraper

Mount the scraper, ensuring the correct orientation.

Apply grease to the inner circumference of packing using something, such as a precision screwdriver.

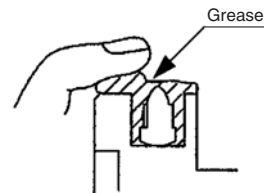

Fig. 4

Caution

Confirm that there is no problem with operation and air tightness after assembly.

6. Replacement Procedure of Shock Absorber

~Series RSH (Fig. 5)~

- 6-1. Loosen two hexagon socket head set screws of the stopper and the shock absorber set screw to remove the stopper from the lever holder.
- 6-2. Push down the lever 90 degrees and loosen the adjusting dial to remove it.
- 6-3. Pull out the shock absorber and replace it with a new shock absorber.
- 6-4. After tightening the adjusting dial, fix the stopper with hexagon socket head cap screws. Before fixing the stopper with hexagon socket head cap screws, apply adhesive to the screws.

- Hexagon socket head capscrew tightening torque: 1.5 N·m

- 6-5. Fix the shock absorber with a set screw.

- Set screw tightening torque: 1.5 N·m

~Series RS2H (Fig. 6)~

- 6-1. Loosen the set screw (M4) of the lever holder which fixes the shock absorber. Push down the lever 90 degrees to pull out the shock absorber.
- 6-2. Fix the shock absorber with a set screw.

- Set screw tightening torque: 1.5 N·m

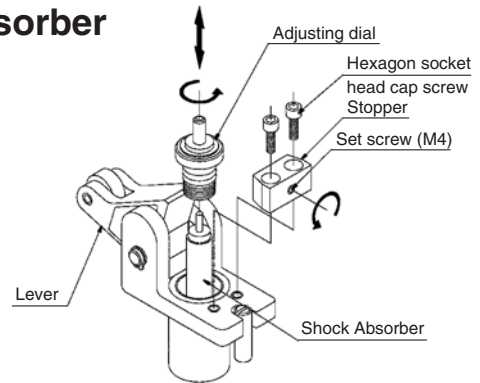

Fig. 5

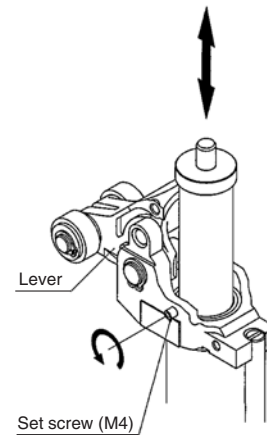

Fig. 6

⚠ Caution

After replacing the shock absorber, tighten the set screw firmly and apply grease to the shock absorber rod end surface (Fig.7).

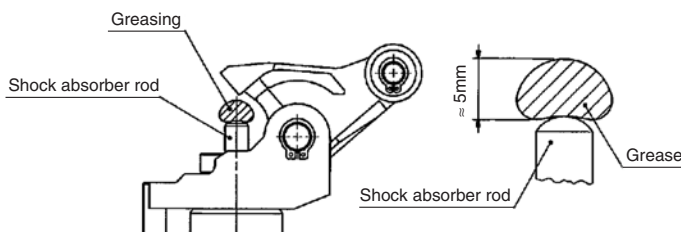

Fig. 7

Series MIW/MIS Replacement Procedure of Finger/Seal 1

1. Replacement Procedure of Finger

- 1-1. Remove the hexagon socket head cap screws.
- 1-2. Remove the cover.
- 1-3. Replace the finger.
 - a. Apply the specified grease to the finger, body, cover and T groove part of the finger.
 - b. Insert the piston in the T groove so that it will be hooked there.
- 1-4. Fix the cover and tighten the hexagon socket head cap screws.

Bore size	Hexagon socket head cap screw	Hexagon width across flats	Tightening torque (N·m)
8	M2 x 6	1.5	0.24
12	M2.5 x 6	2	0.36
20	M4 x 10	3	1.5
25	M5 x 14	4	3.0
32	M6 x 15	5	5.2

Note) For assembly, apply Henkel Japan Loctite No.243 or equivalent adhesive and tighten with the specified tightening torque. Please consult SMC if you feel replacement is difficult.

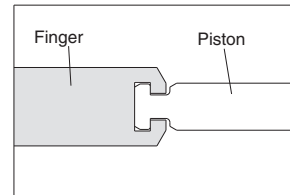
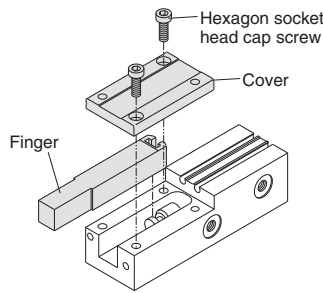
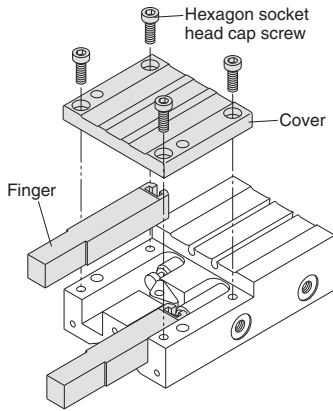

Finger and piston connection

2. Replacement Procedure of Seal

- 2-1. Remove the cover and the finger. (Refer to Replacement Procedure of Finger)
- 2-2. Loosen the hexagon socket set screws. (Refer to the table of hexagon socket set screw size).
 - * For MIS, hexagon socket set screw is not included except for the stroke adjusting type.
- 2-3. Remove the retaining ring with spring pliers to remove the cap.
 - * If there are any questions for ø8, please consult SMC.

Bore size	Hexagon socket set screw	Hexagon width across flats	Tightening torque (N·m)
8	M2 x 6	0.9	0.176
12	M2 x 6	0.9	0.176
20	M3 x 8	1.5	0.63
25	M4 x 8	2	1.5
32	M4 x 8	2	1.5

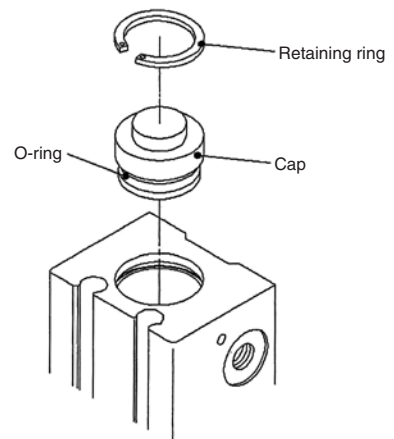
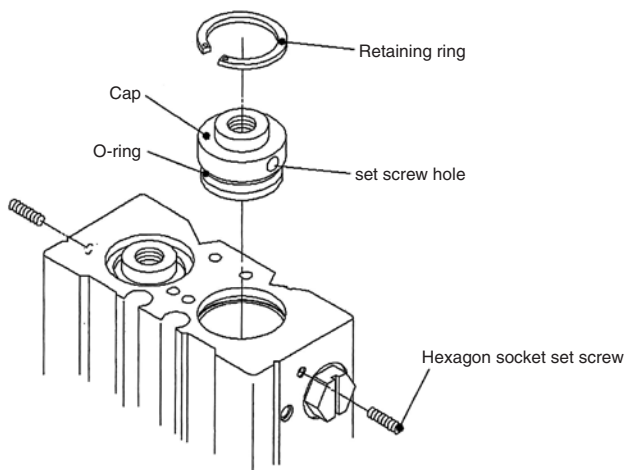

2-4. Take out the piston assembly and replace the seal, to which the specified grease is applied.

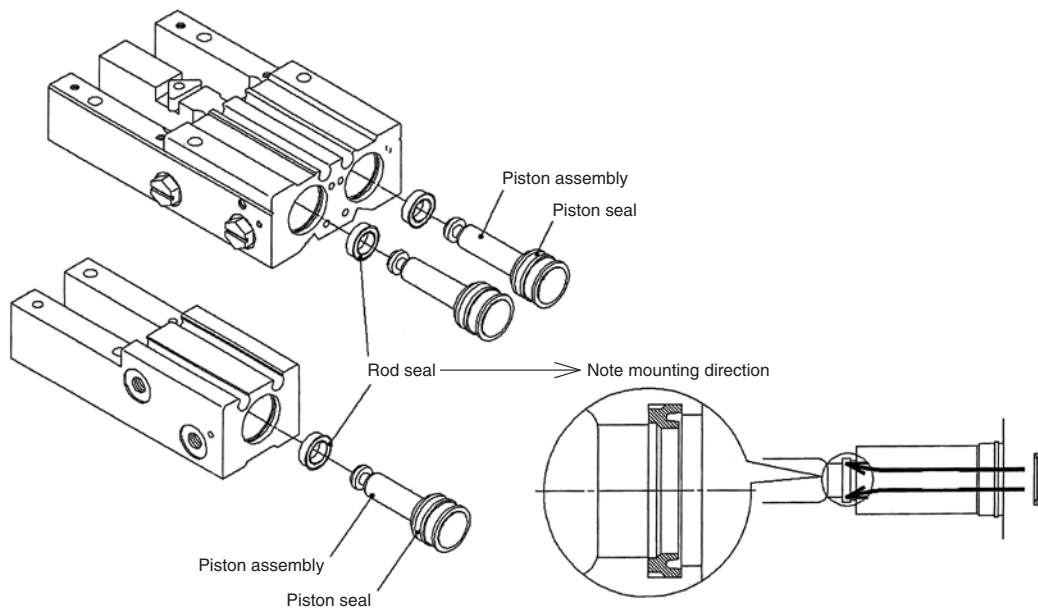

2-5. Apply the specified grease lightly to the sliding interface between the outer periphery and the body of the piston, and assemble them in the reversed order.

3. Scraper Option

Caution

1-1. Please observe the specified torque limits when mounting a scraper.

A tightening torque above the specified limits can cause a damage, while tightening torque below the specified limits can cause a dislocation or drop off.

Tightening torque

Model	Bolt (N·m)
MIW8	0.176
MIS8	
MIW12	0.36
MIS12	
MIW20	0.63
MIS20	
MIW25	0.63
MIS25	
MIW32	1.5
MIS32	

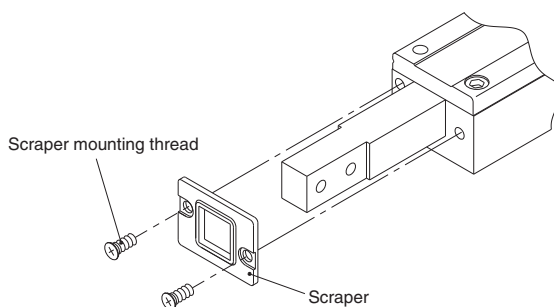
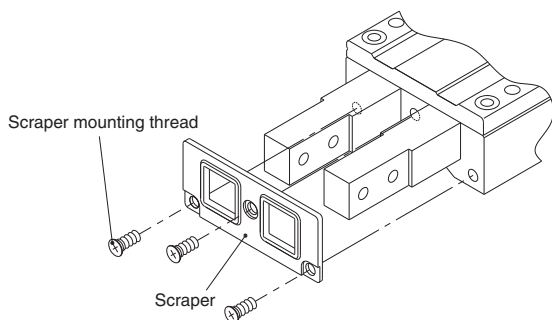

1. Exploded View

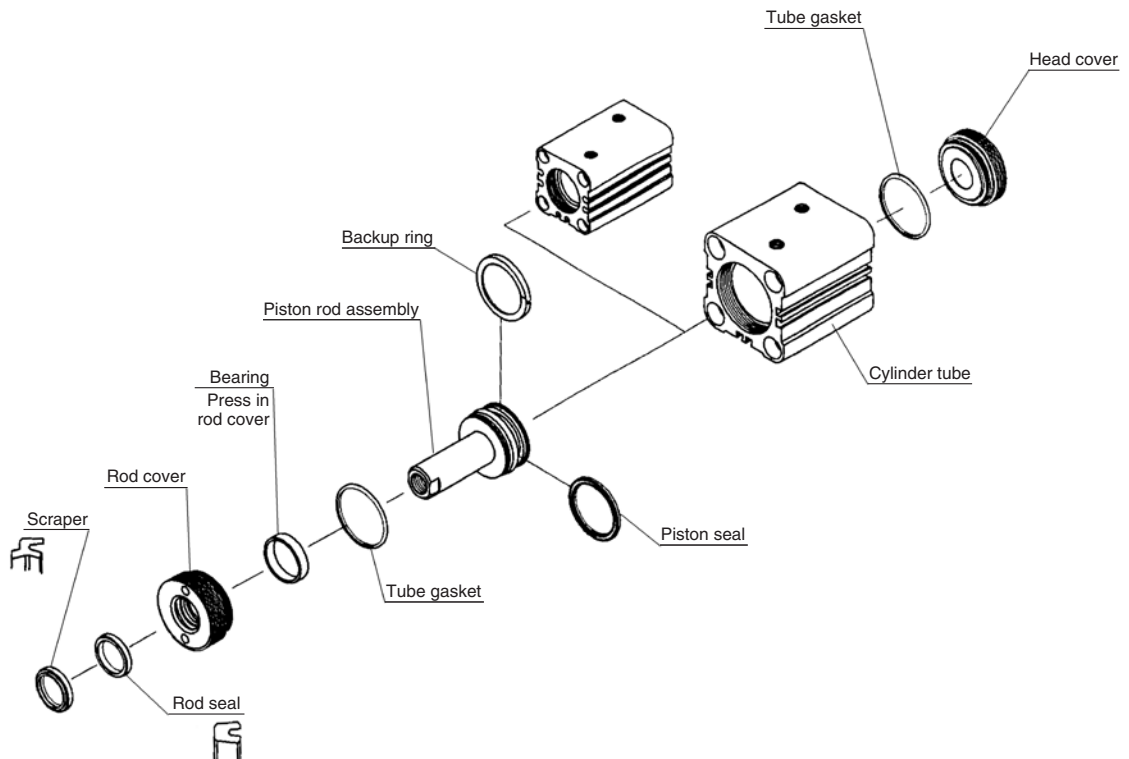

⚠ Caution

1. The piston rod assembly can not be disassembled. The bearing can not be removed because it is pressed into the rod cover.
2. Replace the seal with new one to disassemble and repair the cylinder.
3. If fuel oil such as gasoline and kerosene or solvent are used to wash parts touched to seal, wipe off or dry up them completely before assembling seal.
4. Apply hydraulic fluid (Oil used for the cylinder) or grease to the seal and the housing to be able to move smoothly before assembling.
5. Assemble the seal after confirming the sealing direction.
6. If a driver is used for mounting, round the point of the driver not to make a flaw on the seal and the housing.

7. For handling the seal, take care to avoid excessive extension and deformation.

Cover tightening torque

Bore size (mm)	Tightening torque (N·m)
20	23.5 ± 2.4
25	35.3 ± 3.5
32	68.6 ± 6.8
40	117.7 ± 11.7
50	215.7 ± 21.6
63	372.6 ± 37.3
80	804.1 ± 80.4
100	1470 ± 147

* Remount the cover with the tightening torques listed above.

1. Exploded View

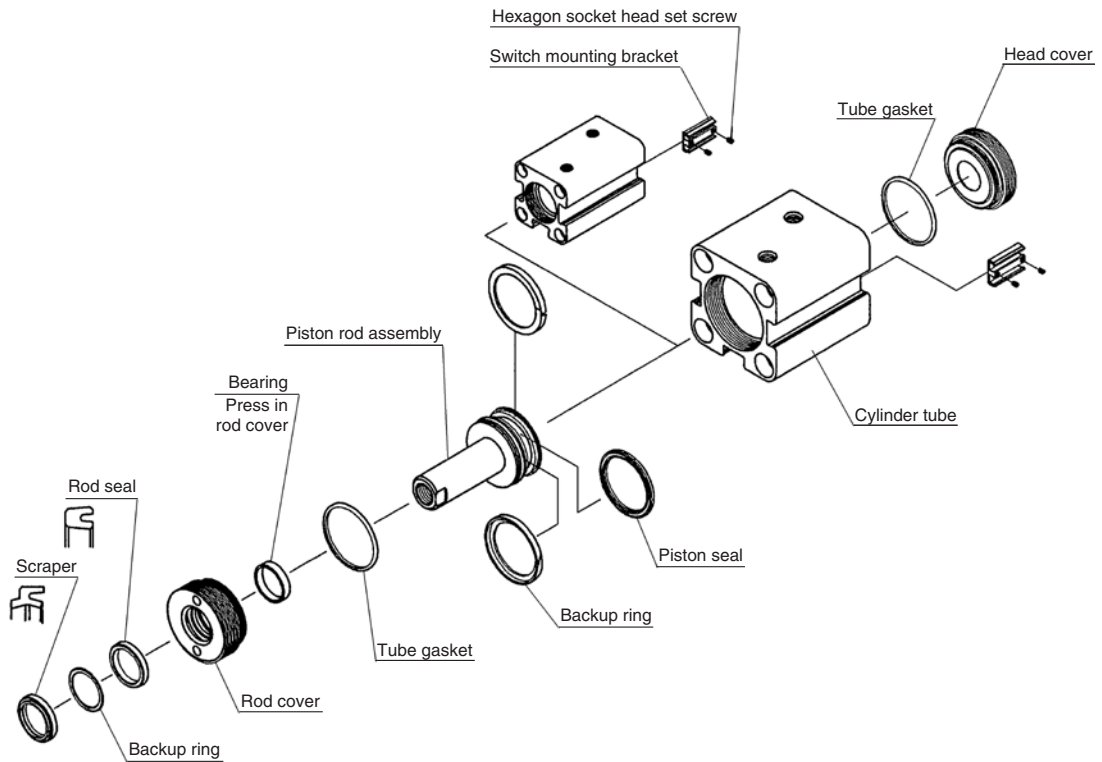

⚠ Caution

1. The piston rod assembly can not be disassembled. The bearing can not be removed because it is pressed into the rod cover.
2. Replace the seal with new one to disassemble and repair the cylinder.
3. If fuel oil such as gasoline and kerosene or solvent are used to wash parts touched to seal, wipe off or dry up them completely before assembling seal.
4. Apply hydraulic fluid (Oil used for the cylinder) or grease to the seal and the housing to be able to move smoothly before assembling.
5. Assemble the seal after confirming the sealing direction.
6. If a driver is used for mounting, round the point of the driver not to make a flaw on the seal and the housing.

7. For handling the seal, take care to avoid excessive extension and deformation.

Cover tightening torque

Bore size (mm)	Tightening torque (N·m)
20	23.5 ± 2.4
25	35.3 ± 3.5
32	68.6 ± 6.8
40	117.7 ± 11.7
50	215.7 ± 21.6
63	372.6 ± 37.3
80	804.1 ± 80.4
100	1470 ± 147

* Remount the cover with the tightening torques listed above.

Actuators

Modular F.R.L.
Pressure Control Equipment

Air Preparation
Equipment

Industrial Filters

Replacement
Procedure

Actuators

Modular F.R.L.
Pressure Control Equipment

Industrial Filters

Series CHN Replacement Procedure of Seal ①

1. Exploded View

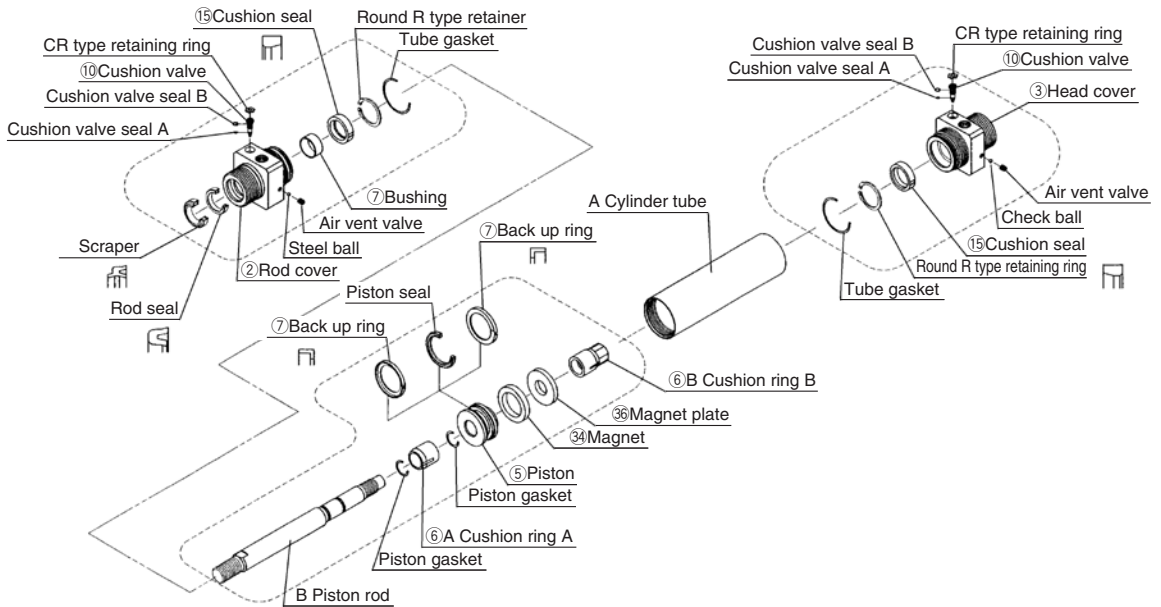

⚠ Caution

1. Rod cover and head cover are screw-in type.
2. Piston rod assembly cannot be disassembled. Bushing cannot be taken out as it is pressed into rod cover.
3. Replace seal at the time of cylinder disassembly and repair.
4. When fuel oil such as gasoline and kerosene or solvent is used to wash the parts that contact seal, thoroughly wipe or dry them off before placing.
5. Apply hydraulic oil (to be used for the cylinder) or grease to seal and housing for smooth sliding.
6. Verify sealing direction and them palece seal.
7. Blunt the tip of a driver not to flaw seal and housing.
8. Carefully handle the seal to avoid excessive elongation and deformation.
9. Please note that the positions of the rod and head covers might move from their original positions upon re-mounting.

1. Exploded View

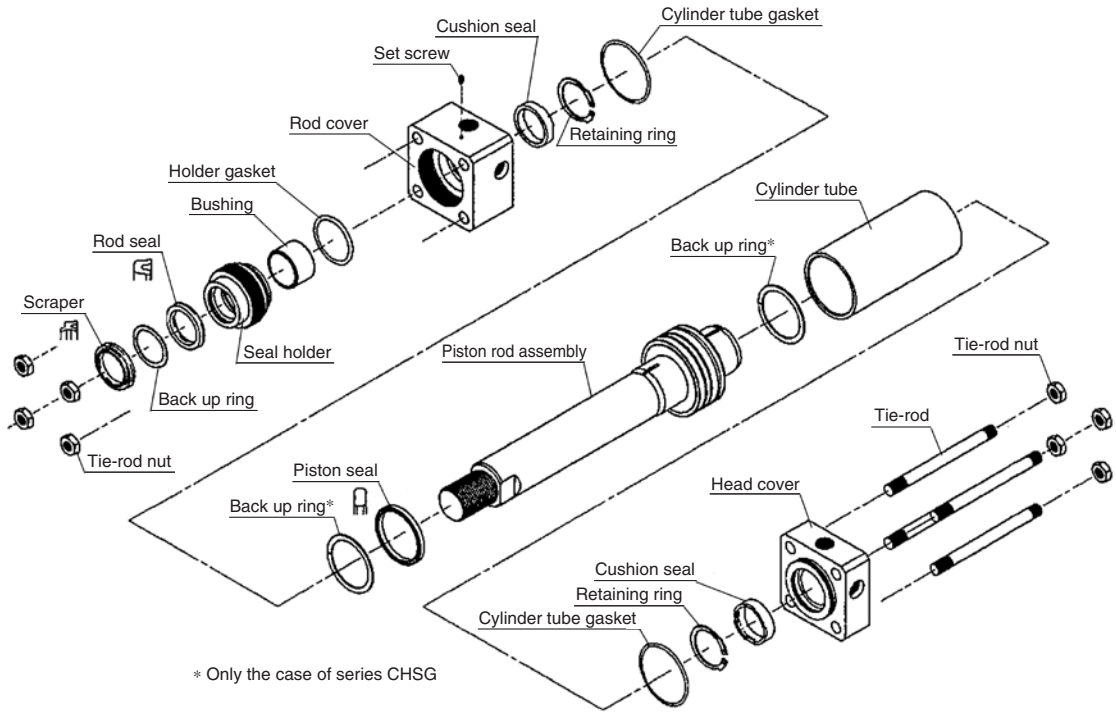

⚠ Caution

1. Piston rod assembly cannot be disassembled. Bushing cannot be taken out as it is pressed into seal holder.
2. Replace seal at the time of cylinder disassembly and repair.
3. When fuel oil such as gasoline and kerosene or solvent is used to wash the parts that contact seal, thoroughly wipe or dry them off before placing.
4. Apply hydraulic oil (to be used for the cylinder) or grease to seal and housing for smooth sliding.
5. Verify sealing direction and then place seal.
6. Blunt the tip of a driver not to flaw seal and housing when it is used for mounting.

7. Carefully handle the seal to avoid excessive elongation and deformation.

Tie-rod nut tightening torque

Bore size (mm)	Tightening torque (N·m)	
	CHSD	CHSG
32		10.8 ± 1.08
40	10.8 ± 1.08	24.5 ± 2.45
50	24.5 ± 2.45	24.5 ± 2.45
63	24.5 ± 2.45	42.2 ± 4.22
80	53.9 ± 5.39	137.3 ± 13.73
100	107.8 ± 10.78	137.3 ± 13.73

* Tighten tie-rod nuts diagonally and equally with torque shown in the table above.

1. Disassembling Drawing

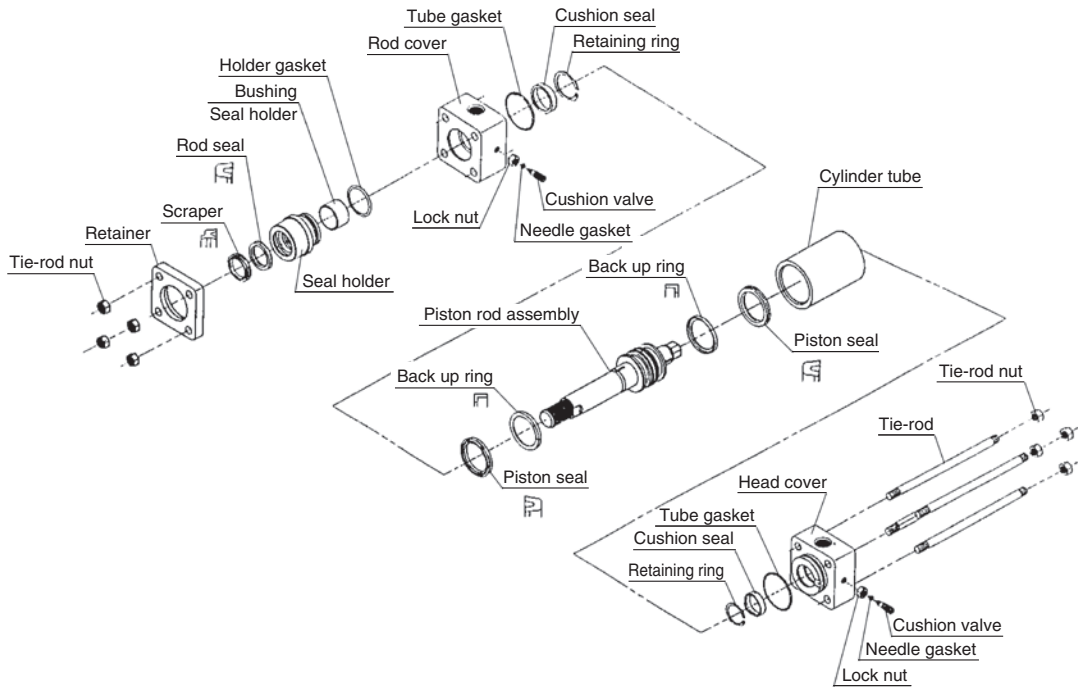

⚠ Caution

1. Piston rod assembly cannot be disassembled. Bearing cannot be taken out as it is pressed into rod cover.
2. Replace seal at the time of cylinder disassembly and repair.
3. When fuel oil such as gasoline and kerosine or solvent is used to wash the parts that contact seal, thoroughly wipe or dry them off before setting.
4. Apply hydraulic oil (to be used for the cylinder) or grease to seal and housing for smooth sliding.
5. Verify sealing direction and then set seal.
6. Blunt the tip of a driver not to scar seal and housing when it is used for mounting.

7. Carefully handle the seal to avoid excessive elongation and deformation.

Tie-rod nut tightening torque

Bore size (mm)	Tightening torque (N·m)		
	CH2E	CH2F	CH2G/H
32	11.8 ± 1.1	14.7 ± 1.4	24.5 ± 2.4
40	11.8 ± 1.1	19.6 ± 1.9	24.5 ± 2.4
50	14.7 ± 1.4	24.5 ± 2.4	24.5 ± 2.4
63	24.5 ± 2.4	39.2 ± 3.9	42.1 ± 4.2
80	44.1 ± 4.4	68.6 ± 6.8	107.8 ± 10.7
100	94 ± 4.9	73.5 ± 7.3	147.1 ± 14.7

* Tighten tie-rod nuts diagonally and equally with torque shown in the table above.