

# Series CS2W

ø125, ø140, ø160

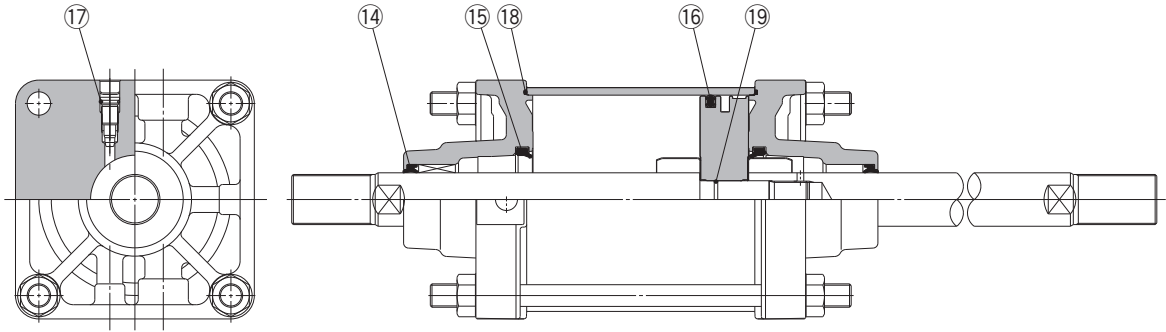

## Construction



\* The numbers are the same as the "Construction" of the CS2 series catalog (CAT.ES20-196).

### Component Parts: Seal Kit List

No.	Description	Material	Note
14	Rod seal	NBR	17 and 19 are non-replaceable parts, so they are not included in the seal kit.
15	Cushion seal	Urethane	
16	Piston seal	NBR	
17	Valve seal	NBR	
18	Tube gasket	NBR	
19	Piston gasket	NBR	

### Replacement Parts: Seal Kit

Bore size (mm)	Kit no.	Contents
125	<a href="#">CS2W125A-PS</a>	Component part numbers: 14, 15, 16, 18.
140	<a href="#">CS2W140A-PS</a>	
160	<a href="#">CS2W160A-PS</a>	

\* Seal kit includes a grease pack (40 g).  
Order with the following part number when only the grease pack is needed.

Grease pack part no.: GR-S-010 (10 g), GR-S-020 (20 g)