

Vacuum Module

Series ZX

Ejector System/Vacuum Pump System



■ For electronic components and precision components up to 100 g

■ Modular design
Customized application function through selection of module components.

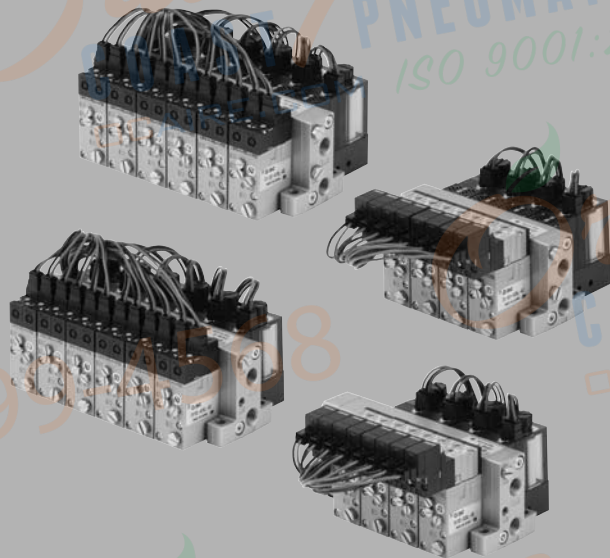

INDEX

Characteristics/Application Examples	P.864
Modular Components Introduction	P.865

Ejector System

How to Order	P.866
Combination of supply valve and release valve	P.868
Construction	P.869
Ejector unit	P.870
Valve unit	P.874
Suction filter unit	P.872
Vacuum pressure switch unit	P.875
Dimensions/Without valve unit	P.881
Dimensions/Combination of supply valve and release valve Type K1, K3, K8, J1, J2	P.882 to 893
Manifold specifications	P.894
Dimensions	P.896 to 901

Vacuum Pump System

How to Order	P.902
Combination of supply valve and release valve	P.904
Construction	P.905
Valve unit	P.906
Suction filter unit/Vacuum pressure switch unit	P.907
Dimensions/Combination of supply valve and release valve Type K1, K3, K6, K8	P.908 to 915
Manifold specifications	P.916
Dimensions	P.918 to 923

Unit Construction

Ejector system/Single, Manifold	P.924
Vacuum pump system/Single, Manifold	P.926
Manifold assembly from individual unit	P.928

Made to Order

1 2 Combinations of supply valve and release valve	P.930
3 High Noise Reduction Silencer Assembly	P.934

ZA

ZX

ZR

ZM

ZMA

ZQ

ZH

ZU

ZL

ZY□

ZF□

ZP□

SP

ZCUK

AMJ

AMV

AEP

HEP

Related
Equipment

Series ZX

For electronic components and precision components up to 100 g

■ **Modular design**

Customized application function through selection of module components.

■ **Compact size and lightweight (120 g with complete unit); well suitable for actuator mounting**

■ **Ejector nozzle size: $\varnothing 0.5$ to $\varnothing 1.0$ (Suction flow: 5 to 22 ℓ/min (ANR))**

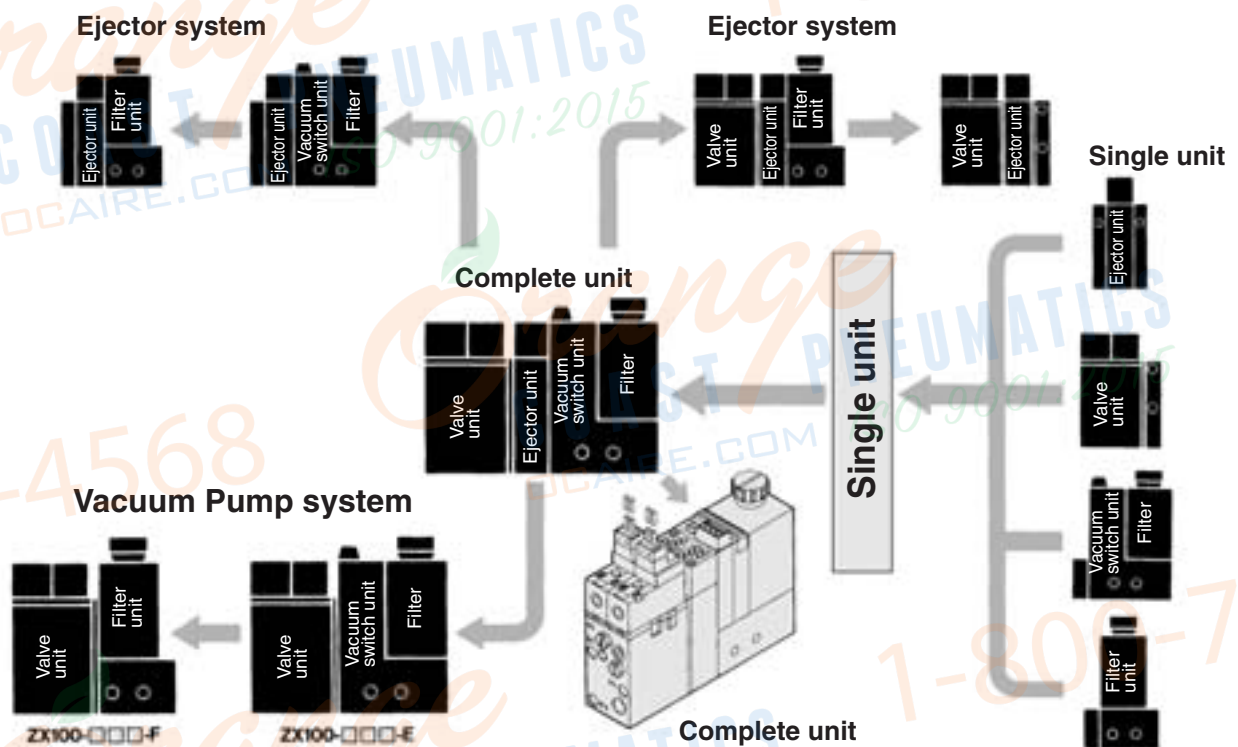

Application Example

Chip bonding

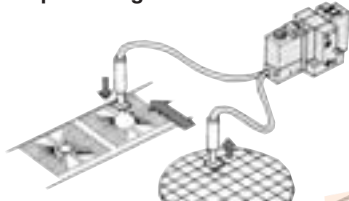

Chip mounting

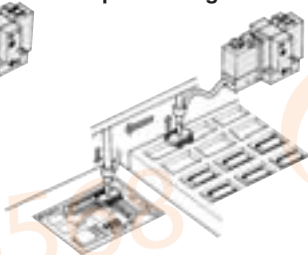

Picking & placing miniature components

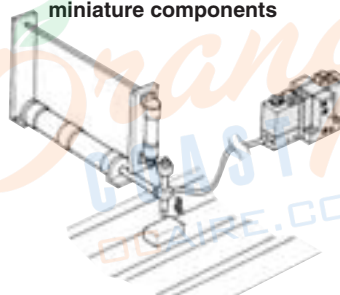

Escorting printed matter

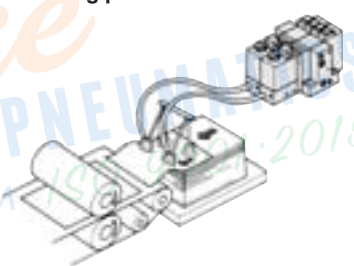

Modular Components Introduction

System		Ejector System			Vacuum Pump System	
Component equipment		P.866 to 901			P.902 to 929	
Characteristics						
Ejector unit Series ZX1 	Nozzle diameter (mm)	0.5	0.7	1.0		
	Max. suction flow (l/min(ANR))	5	10	22		
	Air consumption (l/min(ANR))	13	23	46		
	Maximum vacuum pressure	-84 kPa				
	Exhaust release	Built-in silencer/Manifold exhaust Individual exhaust port: (Rc 1/8)				
Valve unit ZX1-V□ 	Component equipment	Supply valve/Release valve				
	Function	N.C., N.O.				
	Operation	Solenoid valve/Air operated valve				
	Power supply voltage	3, 5, 6, 12, 24 VDC, 100, 110 VAC (50/60 Hz)				
Vacuum pressure switch unit Series ZS 	Series	Vacuum switch	Adsorption confirmation switch	Vacuum switch	Adsorption confirmation switch	
	Set pressure range	0 to -101 kPa	-20 kPa to -101 kPa	0 to -101 kPa	-20 kPa to -101 kPa	
	Hysteresis	3% or less		0.5 kPa		
	Applicable pad diameter (mm)	2 to 25	0.3 to 1.2	2 to 25	0.3 to 1.2	
	Supply voltage	24 VDC		24 VDC		
Suction filter unit ZX1-F 	Operating pressure range	Vacuum to 0.5 MPa				
	Filtration	30 μm				
Common specifications	Unit	Air supply port size	M5 (Standard)/M6 (Option)			
		Vacuum pad connection port size	M5 (Standard)/M6 (Option)			
	Manifold	Air supply port size	Rc 1/8			
		Exhaust port size	Rc 1/8			
		External pilot port size	M5			
		Stations	Max. 8 units			

- ZA
- ZX
- ZR
- ZM
- ZMA
- ZQ
- ZH
- ZU
- ZL
- ZY□
- ZF□
- ZP□
- SP
- ZCUK
- AMJ
- AMV
- AEP
- HEP
- Related Equipment

- Refer to pages 870 to 880 for detailed specifications for each unit.
- Refer to pages 866 and 867 for ejector system unit.
- Refer to page 894 for ejector system manifold.
- Refer to pages 902 and 903 for external vacuum supply system unit.

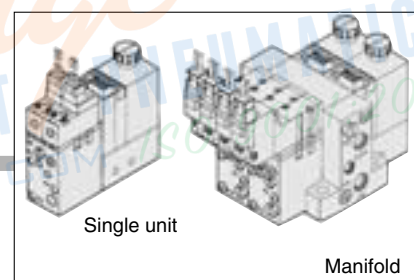
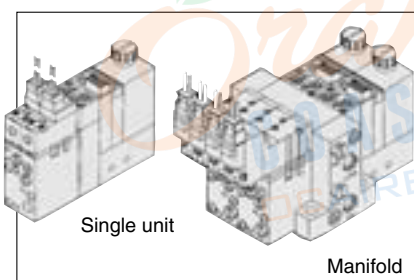

Made to Order
 (Refer to pages 930 to 934 for details.)

- Refer to page 916 for external vacuum supply system manifold.
- Refer to pages 924 to 927 for units for replacement.

Vacuum Module: Ejector System Series ZX



Note) Refer to "How to Order" for CE compliant products. [Option]

How to Order

Components

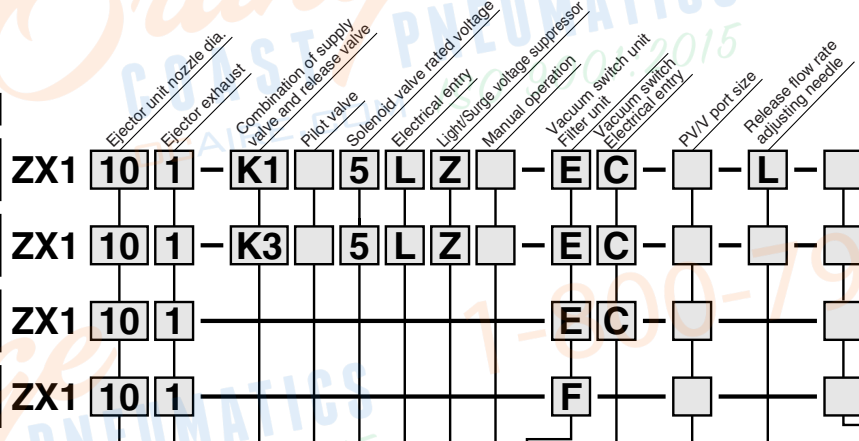
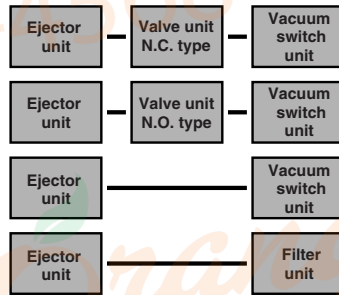

Ejector unit nozzle dia.

05	0.5 mm
07	0.7 mm
10	1.0 mm

Ejector exhaust

1	With silencer
2 ⁽¹⁾	Port exhaust Rc 1/8
3 ⁽²⁾	Common exhaust (Manifold only)

Note 1) When port exhaust is applied to the manifold, pilot exhaust is done by common exhaust. Thus, the exhaust port on the manifold base should be open while operating.

Note 2) When the product is used for the manifold specification and common exhaust, the exhaust air of the operating ejector releases may enter the vacuum (V) port of the non-operating ejector and be released if there are an operating and non-operating ejector. Select either the built-in silencer or port exhaust for the ejector exhaust method.



Valve unit/Combination of supply valve and release valve Refer to "Table (1)" on page 867.

Pilot valve

Nil	DC: 1 W (With indicator light: 1.05 W)
	AC
Y*	DC: 0.45 W (With indicator light: 0.5 W)

* Only 24 VDC and 12 VDC are applicable to 0.45 W.

Solenoid valve rated voltage

1* Note)	100 VAC 50/60 Hz	CE compliant
3* Note)	110 VAC 50/60 Hz	—
5	24 VDC	●
6	12 VDC	●
V	6 VDC	●
S	5 VDC	●
R	3 VDC	●
Nil	Air operated (K6, K8, J3, J4, D3, D4)	—

Note) CE compliant products are not available for "1" and "3".

* Applicable to plug connector only. (Connector assembly with rectifier is attached.)

Electrical entry

L	L plug connector	Lead wire length 0.3 m Without lead wire (Applicable to DC only)
LO	type	Without connector
M	M plug connector	Lead wire length 0.3 m Without lead wire (Applicable to DC only)
MN	type	Without connector
MO	type	Without connector
G	Grommet	Lead wire length 0.3 m (Applicable to DC only)
H	type	Lead wire length 0.6 m (Applicable to DC only)
Nil	Air operated	

Note) In the case of "K1" or "J1" (combination of supply and release valves), M type plug connector can not be used.

Caution

When using the AC type, the DC solenoids are operated via a rectifier. Therefore, when using this type, make sure to combine the connector assembly equipped with a rectifier with the exclusive solenoids. Using other combinations could lead to burned coils or other types of malfunctions.

Caution

Surge voltage suppressor

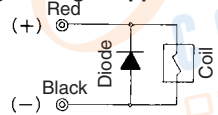

Light/Surge voltage suppressor

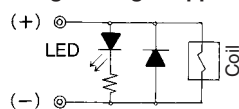

Using the DC type:

Match the polarity of the connectors according to the ⊕ and ⊖ marks on the connectors. Do not interchange the polarities to prevent the diodes or the switching elements from becoming burned.

If lead wires are pre-connected, the red wire is ⊕ and the black wire is ⊖.

Using the AC type:

The AC type is not equipped with a surge voltage suppressor because the rectifier assembly prevents the generation of surge voltage.

Vacuum switch electrical entry

Nil	Grommet type	Lead wire length 0.6 m
L	type	Lead wire length 3 m
C	Connector type	Lead wire length 0.6 m
CL		Lead wire length 3 m
CN	type	Without connector (Without lead wire)

Refer to "Table (3)" on page 867 for part number of lead wire with connector.

Vacuum switch unit/Filter unit

Nil	None	CE compliant
E	Vacuum switch (For general purpose)(ZSE2)(NPN)	●
E55	Vacuum switch (For general purpose)(ZSE2)(PNP)	With suction filter ●
PS Note)	Adsorption confirmation switch (ZSP1)	—
PB Note)	Nozzle dia. (ø0.3 to 0.7)	—
	Nozzle dia. (ø0.5 to 1.2)	—
F	Only suction filter	● Except air operated parts

Note) CE compliant products are not available for "PS" and "PB".

Vacuum digital pressure switch unit (ZSE3)

D	21	2 outputs/without analog output
	22	2 outputs/with analog output
	23	1 output (with trouble detection)/without analog output
	24	1 output (with trouble detection)/with analog output

Note) Analog output is available only on grommet type.

Manual operation

Nil	Non-locking push type
B	Locking slotted type

Light/Surge voltage suppressor

Nil	None
Z	With light/surge voltage suppressor
S*	With surge voltage suppressor

* S is not available for AC.

DC voltage (with surge voltage suppressor)

If the polarity is incorrect at DC (surge voltage suppressor), diode or switching element may be damaged.

- Refer to "Table (2)" on page 867 for part number of lead wire with connector.
- Refer to page 894 for ordering the manifold.
- Refer to pages 924 and 925 for ordering a unit for replacement.



Made to Order

(Refer to pages 930 to 934 for details.)

Table (1) Valve Unit/Combination of Supply Valve and Release Valve (Refer to page 868 for detailed specifications.)

Components		Symbol	Supply valve					Release valve					Mass (g)	
Supply valve	Release valve		Solenoid valve		Air operated			None	Solenoid valve		Air operated	External release		None
			N.C. (VJ114)	N.O. (VJ324)	N.C. (ZX1A)	N.O. (VJA324)	N.C. (VJ114)		N.C. (VJ314)	N.C. (VJA314)	ZX1A			
Solenoid (N.C.)	Solenoid (N.C.)	K1	●	—	—	—	—	●	—	—	—	—	—	82
Solenoid (N.O.)	Solenoid (N.C.)	K3	—	●	—	—	—	—	●	—	—	—	—	132
Air operated (N.C.)	External release	K6	—	—	●	—	—	—	—	—	●	—	—	58
Air operated (N.O.)	Air operated (N.C.)	K8	—	—	—	●	—	—	—	●	—	—	—	132
Solenoid (N.C.)	None	J1	●	—	—	—	—	—	—	—	—	●	—	77
Solenoid (N.O.)	None	J2	—	●	—	—	—	—	—	—	—	—	●	100
—		Nil	Without valve module											

- Air operated valve: Controlled by external 3 port valve.
- External release: Directly released by external 2 port valve.

Table (2) Valve Unit/Valve Plug Connector Assembly

Connector assembly part no.
(For DC)

VJ10-20-4A-6

(For 100 VAC)

VJ10-36-1A-6

(For 110 VAC)

VJ10-36-3A-6

Lead wire length	
Nil	0.3 m (Standard)
6	0.6 m
10	1 m
15	1.5 m
20	2 m
25	2.5 m
30	3 m

How to order

If ordering vacuum module with 600 mm or the longer lead wire, specify both vacuum module and connector assembly part numbers.

Ordering example)

ZX1051-K15LOZ-EC(-Q) ... 1 pc.
*VJ10-20-4A-6 2 pcs.

Table (3) Vacuum Switch/Lead Wire with Connector

For ZSE2
For ZSP1 **ZS-10-5A-**

For ZSE3 **ZS-20-5A-**

Note) If ordering a vacuum switch with 3 m lead wire, specify both the vacuum unit switch and the 3 m lead wire with connector part numbers.

Ordering example)
ZX1051-K15LO-ECN(-Q) ... 1 pc.
*VJ10-20-4A-6 2 pcs.
*ZS-10-5A-50 1 pc.

↳ The asterisk (*) denotes the symbol for assembly.

Lead wire length	
Nil	0.6 m
30	3 m
50	5 m

Ejector System/Recommended Model (The models below will have shorter deliveries.)

Nozzle diameter (mm)	Model	Ejector unit exhaust type	Combination		Solenoid valve rated voltage	Lead wire electrical entry	Light/ Surge voltage suppressor	Vacuum switch unit	Vacuum switch electrical entry
			Supply valve (Pilot valve)	Release valve (Direct operated)					
0.5	ZX1051-K15LZ-EC	With silencer	N.C. (VJ114)	N.C. (VJ114)	24 VDC	Plug connector type	With light/surge voltage suppressor	General vacuum switch (ZSE2)	Connector type
	ZX1051-K35MZ-EC		N.O. (VJ324M)	N.C. (VJ314)					
0.7	ZX1071-K15LZ-EC		N.C. (VJ114)	N.C. (VJ114)					
	ZX1071-K35MZ-EC		N.O. (VJ324M)	N.C. (VJ314)					
1.0	ZX1101-K15LZ-EC		N.C. (VJ114)	N.C. (VJ114)					
	ZX1101-K35MZ-EC		N.O. (VJ324M)	N.C. (VJ314)					

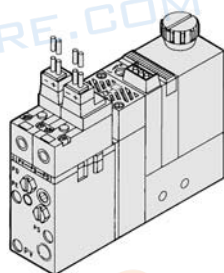

ZX1051-K15LZ-EC

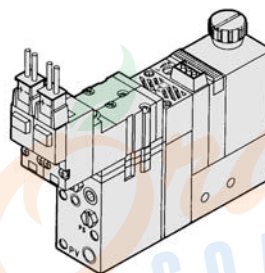

ZX1051-K35MZ-EC



- ZA
- ZX
- ZR
- ZM
- ZMA
- ZQ
- ZH
- ZU
- ZL
- ZY□
- ZF□
- ZP□
- SP
- ZCUK
- AMJ
- AMV
- AEP
- HEP

Related Equipment

Ejector System/Combination of Supply Valve and Release Valve

Combination Symbol: K1

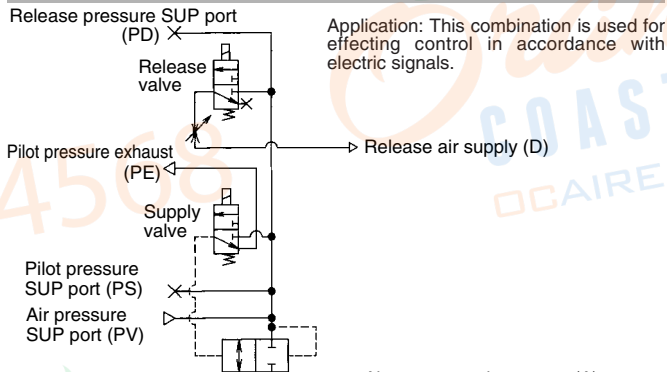

Application: This combination is used for effecting control in accordance with electric signals.

How to Operate

Condition	Valve	Supply valve (N.C.) Solenoid valve	Release valve (N.C.) Solenoid valve
1. Work adsorption		ON	OFF
2. Vacuum release		OFF	ON
3. Operation stop		OFF	OFF

Combination Symbol: K8

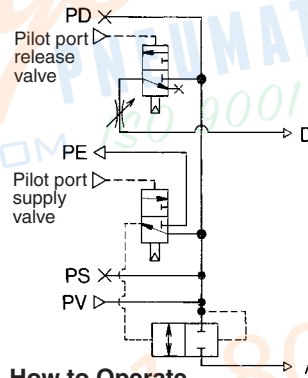

Application: This combination is used for effecting control in accordance with air signals. Because the supply valve is N.O., the pressure that is supplied to the ejector is not interrupted during a power outage; as a result, the state of suction can be maintained. This combination is used for preventing the workpieces from dropping during power outages.

How to Operate

Condition	Valve	Supply valve (N.O.) Air operated valve	Release valve (N.C.) Air operated valve
1. Work adsorption		OFF	OFF
2. Vacuum release		ON	ON
3. Operation stop		ON	OFF

Combination Symbol: K3

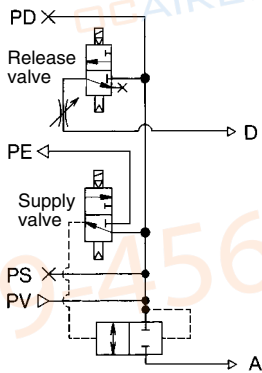

Application: This combination is used for effecting control in accordance with electric signals. Because the supply valve is N.O., the pressure that is supplied to the ejector is not interrupted during a power outage; as a result, the state of suction can be maintained. This combination is used for preventing the workpieces from dropping during power outages.

How to Operate

Condition	Valve	Supply valve (N.O.) Solenoid valve	Release valve (N.C.) Solenoid valve
1. Work adsorption		OFF	OFF
2. Vacuum release		ON	ON
3. Operation stop		ON	OFF

Combination Symbol: J1

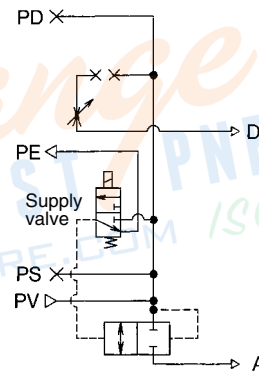

Application: This combination is used for effecting control in accordance with electric signals. A vacuum release is effected by the intrusion of air between the silencer, pad, and the workpiece. This combination is used when there is no need to accelerate the vacuum release speed.

How to Operate

Condition	Valve	Supply valve (N.C.) Solenoid valve	Release valve None
1. Work adsorption		ON	—
2. Vacuum release		OFF	—
3. Operation stop		OFF	—

Combination Symbol: K6

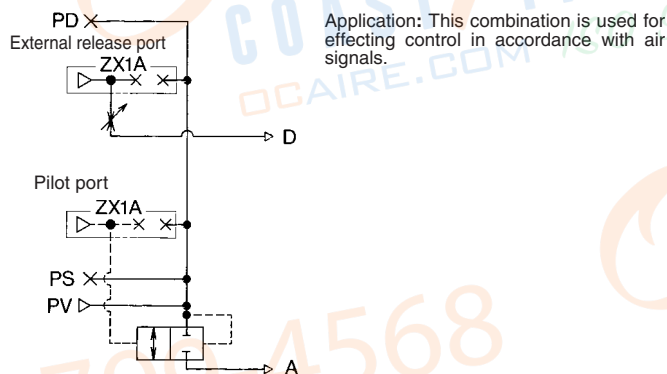

Application: This combination is used for effecting control in accordance with air signals.

How to Operate

Condition	Valve	Supply valve External 3 port valve	Release valve External 2 port valve
1. Work adsorption		ON	OFF
2. Vacuum release		OFF	ON
3. Operation stop		OFF	OFF

Combination Symbol: J2

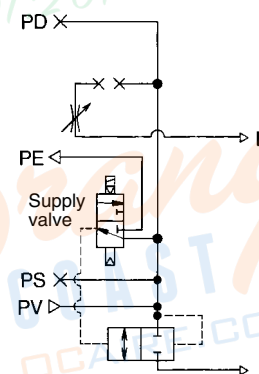

Application: This combination is used for effecting control in accordance with electric signals. Because the supply valve is N.O., the pressure that is supplied to the ejector is not interrupted during a power outage; as a result, the state of suction can be maintained. This combination is used for preventing the workpieces from dropping during power outages. A vacuum release is effected by the intrusion of air between the silencer, pad, and the workpiece. This type is used when there is no need to accelerate the vacuum release speed.

How to Operate

Condition	Valve	Supply valve (N.O.) Solenoid valve	Release valve None
1. Work adsorption		OFF	—
2. Vacuum release		ON	—
3. Operation stop		OFF	—

Ejector System/Construction

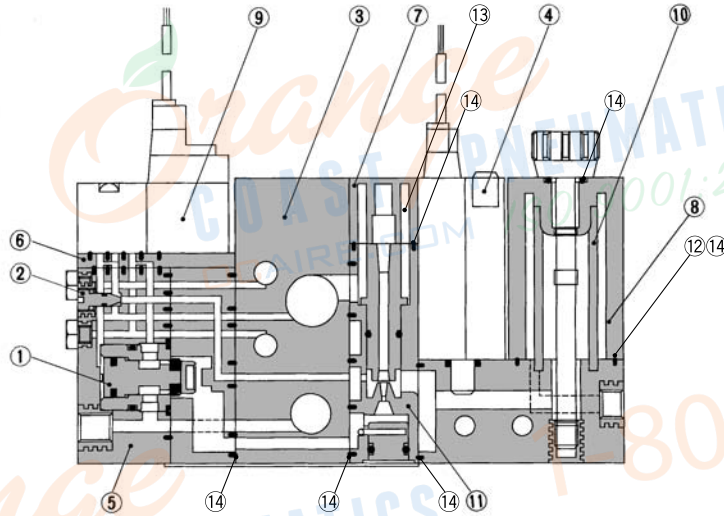

Component Parts

No.	Description	Material	Note
1	Poppet valve assembly	—	ZX1-PV-0
2	Release flow rate adjustment needle	Stainless steel	ZX1-NA
3	Manifold base	Aluminum	
4	Vacuum switch	—	ZSE2, ZSP1, ZSE3
5	Valve unit	—	ZX1-VA□□□□□□-D-□
6	Interface plate	—	(PV↔PS↔PD)
7	Silencer case	—	
8 (Note)	Filter case	Polycarbonate	

Replacement Parts

No.	Description	Material	Part no.
9	Pilot valve Air operated	—	☞ Refer to "Table (1)", "(2)", "(3)".
10	Filter element	PVF	ZX1-FE
11	Ejector assembly	—	☞ Refer to "Table (4)".
12	Gasket	—	ZX1-FG
13	Silencer element	—	ZX1-SAE
14	Seal set	—	ZX1-PK
(7,13)	Silencer assembly	—	ZX1-HS2-□ (□: Nozzle diameter)

Note) Caution when handling filter case

- 1) The case is made of polycarbonate. Therefore, do not use with or expose it to the following chemicals: paint thinner, carbon tetrachloride, chloroform, acetic ester, aniline, cyclohexane, trichloroethylene, sulfuric acid, lactic acid, watersoluble cutting oil (alkalinic), etc.
- 2) Do not expose it to direct sunlight.

Table (1) How to Order Pilot Valves

No.	Components		Model	Combination of supply and release valve
	Supply valve	Release valve		
①	Solenoid valve N.C. (VJ114)	Solenoid valve N.C. (VJ114)	ZX1-VJ114-□□□□	K1, J1
②	Solenoid valve N.O. (VJ324)	Solenoid valve N.C. (VJ314)	ZX1-VJ3 ¹ / ₂ 4□-□□□□	K3, J2
③	Air operated N.O. (VJA324)	Air operated N.C. (VJA314)	ZX1-VJA3 ¹ / ₂ 4	K8
④	Air operated N.C. (ZX1A)		ZX1A-□	K6

Table (2) How to Order Solenoid Valves

ZX1-VJ114 □ - **5** **L** **Z** □

ZX1-VJ3¹/₂4 □ - **5** **L** **Z** □

Type of actuation

1	N.C. (Normally closed)
2	N.O. (Normally open)

Manual override

Nil	Non-locking push type
B	Locking slotted type

Light/Surge voltage suppressor

Nil	Without light/surge voltage suppressor
S	With surge voltage suppressor
Z	With light/surge voltage suppressor

Electrical entry

L	Connector (0.3 m)
LN	Connector (w/o lead wire)
LO	Without connector
M	Connector (0.3 m)
MN	Connector (w/o lead wire)
MO	Without connector
G	Grommet (0.3 m)
H	Grommet (0.6 m)

Rated voltage

1*	100 VAC
3*	110 VAC
5	24 VDC
6	12 VDC
V	6 VDC
S	5 VDC
R	3 VDC

* Applicable to plug connector only.

Pilot valve

Nil	DC: 1 W (With indicator light: 1.05 W)
AC	AC
γ*	DC: 0.45 W (With indicator light: 0.5 W)

* Only 24 VDC and 12 VDC are applicable to 0.45 W.
Note) Screw length of VJ100 and VJ300 for series ZX is different from that of the standard model.
-<Screw length> VJ100-M1.7 x 15
VJ300-M1.7 x 22

Note) In the case of N.C. type, indicate no symbol. (Individual exhaust for Pilot valve)
Note) Compatible with ZX1-VJ324M-□ and ZX1-VJ314-□ only.

Note) In the case of "ZX1-VJ114", M, MN and MO cannot be used.

Table (3) How to Order Air Operated Valves

ZX1A - M3

Port size

M3	M3 x 0.5	Pilot port/
M5	M5 x 0.8	External release port

Table (4) How to Order Ejector Assembly

ZX1-W D 05 1

Assembly no. Ejector type (Exhaust type)

Ejector unit nozzle dia.

05	0.5 mm
07	0.7 mm
10	1.0 mm

1	With silencer
2	Port exhaust
3	Common exhaust

* An adapter should be attached to the assembly to be used as a unit. PV port and V port can be connected.

Ejector assembly □ Combination/ ZX1-WD □

□ Used as a unit by attaching an adapter/ ZX1-W □

Caution

Turning the vacuum release flow volume adjustment needle clockwise reduces the vacuum release flow volume; the needle valve is fully closed when the needle stops turning. Turning the needle 2 full turns counterclockwise from the fully closed position renders the needle valve fully open. The needle will fall out if it is turned more than 4 full turns.
In order to prevent the needle from loosening and falling out, the release flow volume adjustment needle with lock nut is also available.

ZA

ZX

ZR

ZM

ZMA

ZQ

ZH

ZU

ZL

ZY □

ZF □

ZP □

SP

ZCUK

AMJ

AMV

AEP

HEP

Related Equipment

Ejector Unit



Specifications

Unit no.	ZX1-W05 ¹ ₂	ZX1-W07 ¹ ₂	ZX1-W10 ¹ ₂
Nozzle dia. (mm)	0.5	0.7	1.0
Max. suction flow (l/min (ANR))	5	10	22
Air consumption (l/min (ANR))	13	23	46
Maximum vacuum pressure	-84 kPa		
Maximum operating pressure	0.7 MPa		
Supply pressure range	0.2 MPa to 0.55 MPa		
Standard supply pressure	0.45 MPa		
Operating temperature range	5 to 50°C		
Ejector exhaust type *	Code ①	Built-in silencer..... For single unit and manifold	
	Code ②	Individual exhaust..... For single unit and manifold	
Mass	Built-in silencer: 35 g/Port exhaust: 45 g		
Standard accessory	Bracket B (ZX1-OB B)		

* Codes ① and ② are corresponding to the suffixes in "How to Order" to indicate the ejector exhaust method.

How to Order

ZX1 — W 05 1

Nozzle diameter

05	0.5 mm
07	0.7 mm
10	1.0 mm

PV, V port size

Nil	M5 x 0.8
Y	M6 x 1 (Option)

Ejector exhaust method

1	Silencer
2	Individual exhaust Rc 1/8

Dimensions: ZX1-W□□₂¹

JIS Symbol

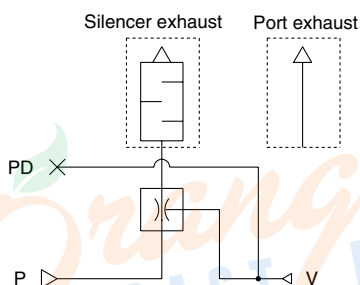

Release pressure SUP port (PD)
M5 (or M6)
Plug Note)

Air pressure SUP port (P)
M5 (or M6)

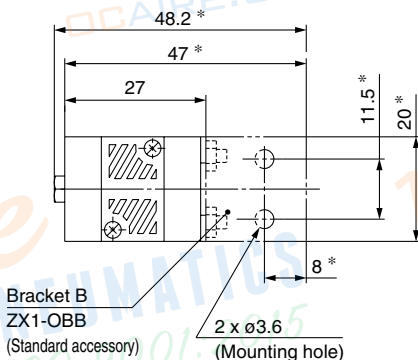
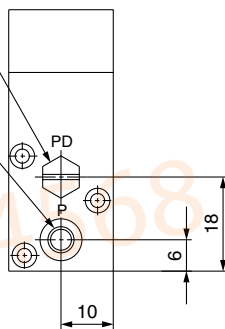

Bracket B
ZX1-OB B
(Standard accessory)

2 x ø3.6
(Mounting hole)

Port exhaust

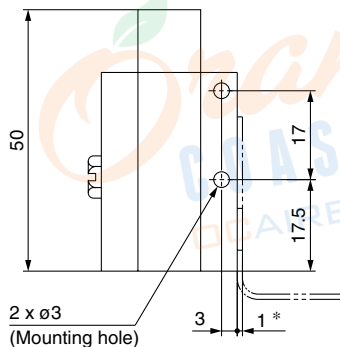
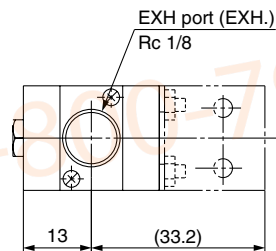

2 x ø3
(Mounting hole)

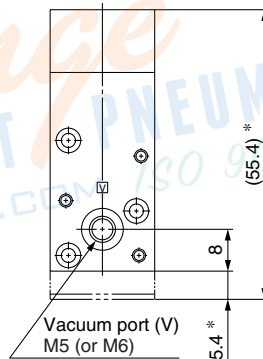

Vacuum port (V)
M5 (or M6)



Note 1) Remove the plug at external release. Note 2) Dimensions *: For mounting bracket B.

Flow Characteristics/Exhaust Characteristics

[At 0.45 MPa]

ZX1-W05

How to Read Flow Characteristics Graph

Exhaust Characteristics

Flow Characteristics

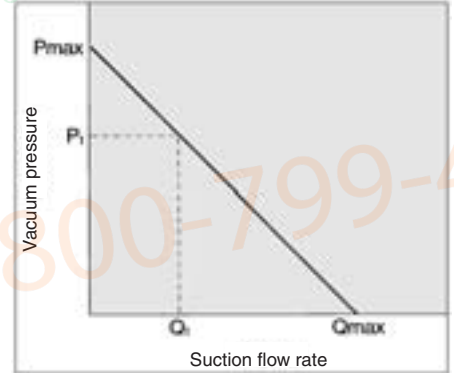
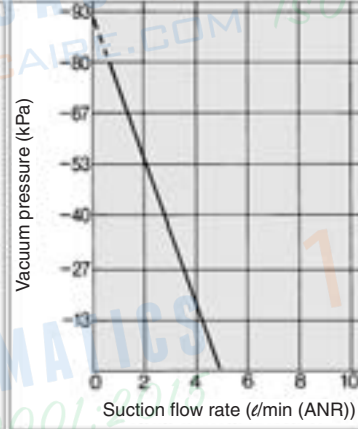
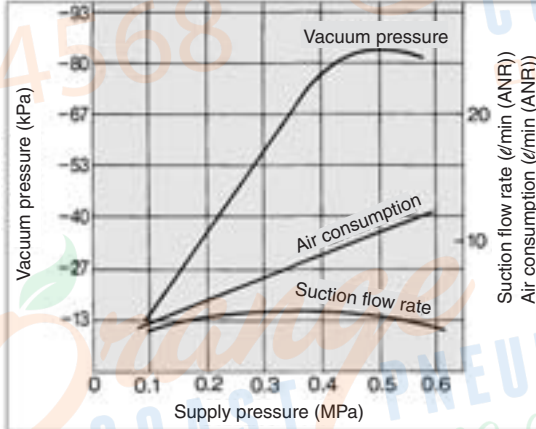

Flow characteristics are expressed in ejector vacuum pressure and suction flow. If suction flow rate changes, a change in vacuum pressure will also be expressed. Normally this relationship is expressed in ejector standard use.

In graph, Pmax. is max. vacuum pressure and Qmax is max. suction flow. The valves are specified according to catalog use. Changes in vacuum pressure are expressed in the below order.

1. When ejector suction port is covered and made airtight, suction flow becomes 0 and vacuum pressure is at maximum value (Pmax).
2. When suction port is opened gradually, air can flow through, (air leakage), suction flow increases, but vacuum pressure decreases. (condition P₁ and Q₁)
3. When suction port is opened further, suction flow moves to maximum value (Qmax), but vacuum pressure is near 0. (atmospheric pressure).

When vacuum port (vacuum piping) has no leakage, vacuum pressure becomes maximum, and vacuum pressure decreases as leakage increases. When leakage value is the same as max. suction flow, vacuum pressure is near 0.

When ventilative or leaky work must be adsorbed, please note that vacuum pressure will not be high.

ZX1-W07

Exhaust Characteristics

Flow Characteristics

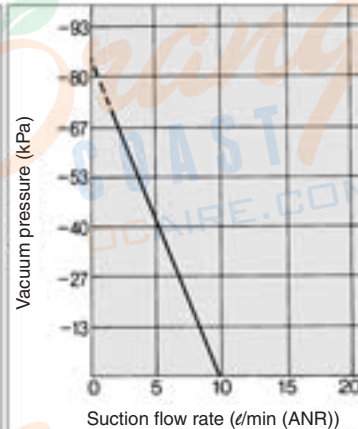
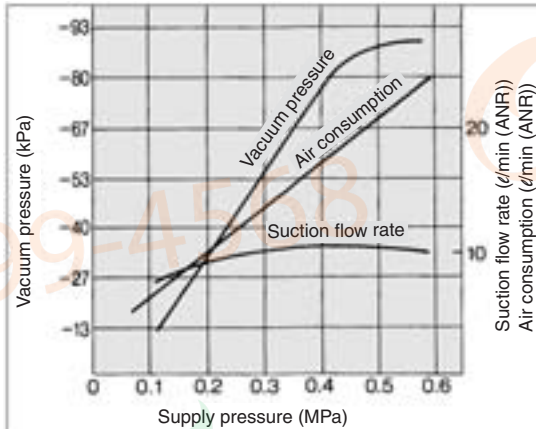

ZX1-W10

Exhaust Characteristics

Flow Characteristics

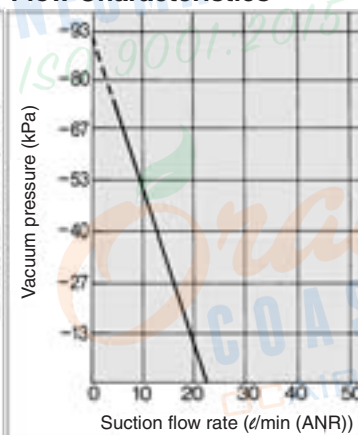
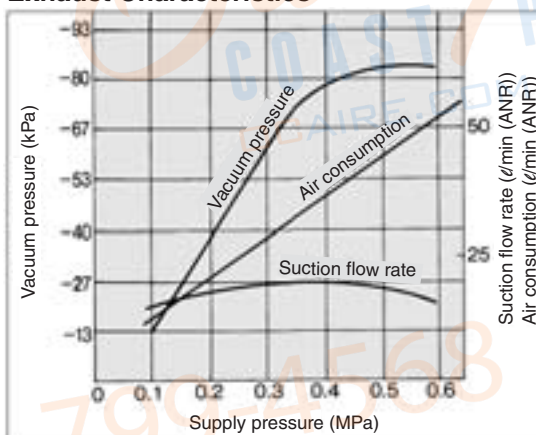

⚠ Precautions

Be sure to read before handling. Refer to front matters 38 and 39 for Safety Instructions and pages 844 to 846 for Vacuum Equipment Precautions.

⚠ Caution

Refer to the vacuum equipment model selection on pages 825 to 843 for the selection and sizing of Series ZX.

ZA
ZX
ZR
ZM
ZMA
ZQ
ZH
ZU
ZL
ZY□
ZF□
ZP□
SP
ZCUK
AMJ
AMV
AEP
HEP
Related Equipment

Series ZX

Valve Unit: ZX1-VA



Model/Specifications

Unit no.	ZX1-VA□□□□□□□(-Q)							
Components	Supply valve				Release valve			
	Pilot operated				Direct operated			
Operation	Solenoid valve		Air operated		Solenoid valve		External release	Air operated
	N.C. (VJ114)	N.O. (VJ324M)	N.C. (ZX1A)	N.O. (VJA324)	N.C. (VJ314)	N.C. (VJ114)	(ZX1A)	N.C. (VJA314)
Cv factor	0.17 Main valve			0.08	0.008	—		
Operating pressure range	0.3 to 0.6 MPa							
Max. operating frequency	5 Hz							
Operating temperature range	5 to 50°C							
Interface plate symbol	PV↔PS↔PD							
Standard accessory	Bracket C(ZX1-OBC)							

Solenoid Valve Specifications

	VJ114	VJ314, VJ324
Rated voltage	24, 12, 6, 5, 3 VDC/100, 110 VAC* (50/60 Hz)	
Electrical entry	L plug connector, grommet L plug connector, M plug connector, grommet	
Light/Surge voltage suppressor	With or Without	
Manual operation	Non-locking push type/Locking slotted type	

* Applicable to plug connector only. Connector assembly with rectifier is attached.

Model/Solenoid Valve

		Supply valve			
		Solenoid valve N.C. (VJ114)	Solenoid valve N.O. (VJ324M)	Air operated N.C. (ZX1A)	None
Release valve	Solenoid valve N.C. (VJ114)	● K1 [82]	—	● K5 [73]	● D1 [77]
	Solenoid valve N.C. (VJ314)	—	● K3 [132]	—	● D2 [100]
	External release (ZX1A)	● K2 [73]	—	● K6 [58]	● D3 [41]
	Air operated N.C. (VJA314)	—	● K4 [119]	—	● D2 [100]
	None	● J1 [77]	● J2 [100]	● J3 [41]	—

[]: Mass (g)

How to Order / Refer to page 866 for details.

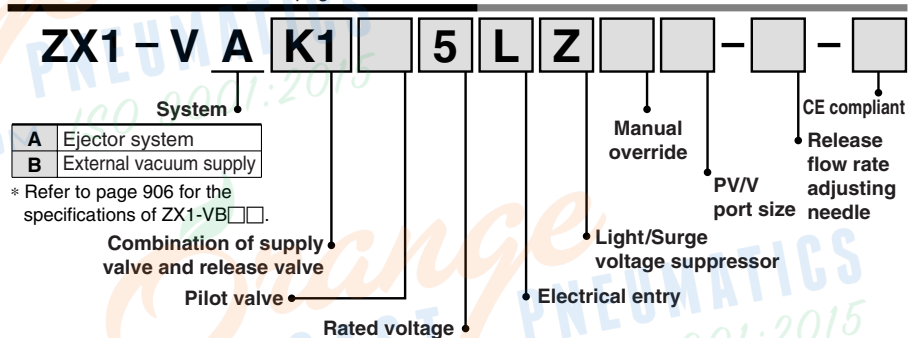

Connector Assembly for 100 VAC

Connector assembly with rectifier attached.

Connector Assembly with Rectifier Part No.

VJ10 - 36 - [] A - []

Rated voltage

Symbol	Rated voltage	Lead wire color
1	100 VAC 50/60 Hz	Blue (2 pcs.)
3	110 VAC 50/60 Hz (115 VAC 60 Hz)	Gray (2 pcs.)

Lead wire length

Symbol	L mm
Nil	300
6	600
10	1000
15	1500
20	2000
25	2500
30	3000

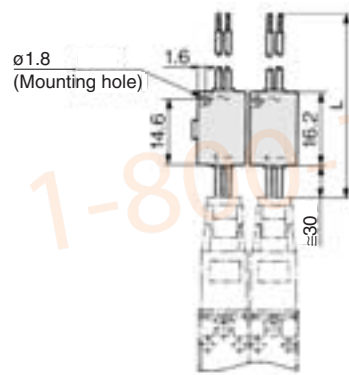

Valve Unit

Normally closed

A: Release flow rate adjusting needle with lock nut

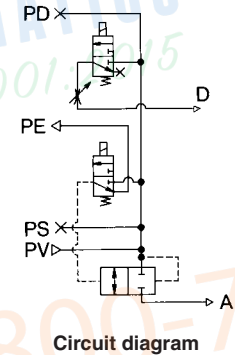
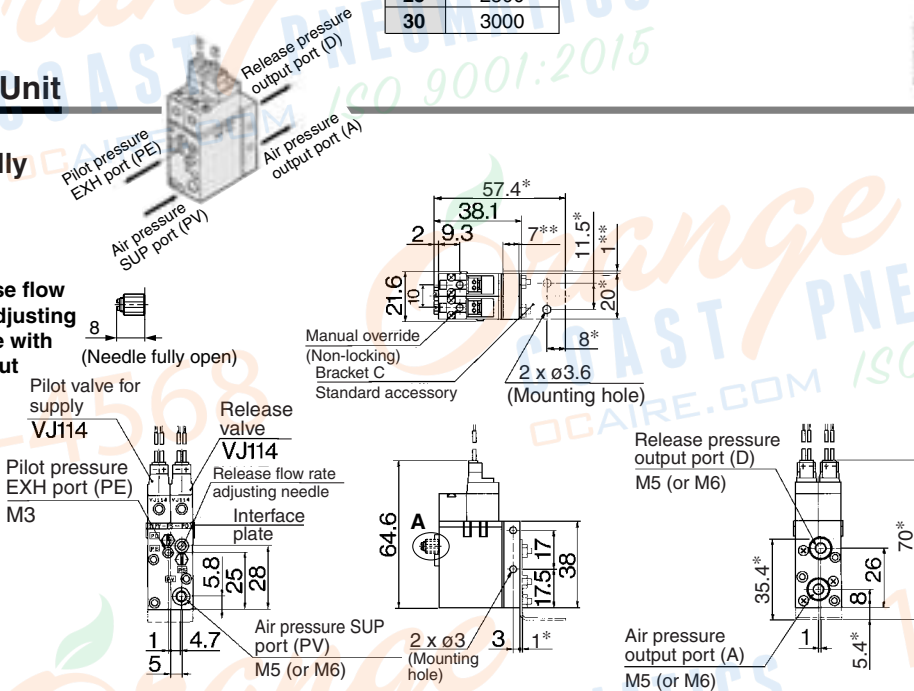

Normally open

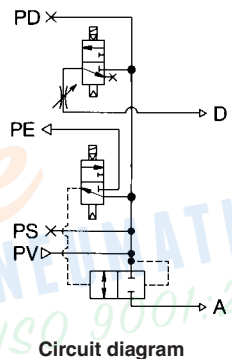
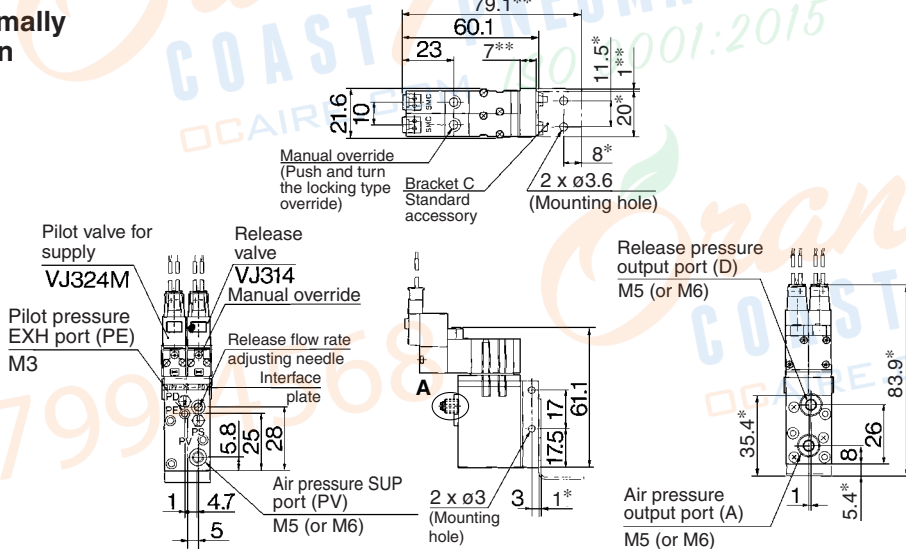

Note) Dimensions *: For mounting bracket C **: For mounting spacer.

- ZA
- ZX
- ZR
- ZM
- ZMA
- ZQ
- ZH
- ZU
- ZL
- ZY□
- ZF□
- ZP□
- SP
- ZCUK
- AMJ
- AMV
- AEP
- HEP
- Related Equipment

Suction Filter Unit: ZX1-F



Specifications

Unit no.	ZX1-F
Operating pressure range	—100 to 500kPa
Operating temperature range	5 to 50°C
Filtration efficiency	30 μm
Element	PVF
Mass	35 g
Standard accessory	Bracket A (ZX1-OBA)



Note) If not operated within the specified range of pressure and temperature, trouble may result.

Filter

JIS Symbol

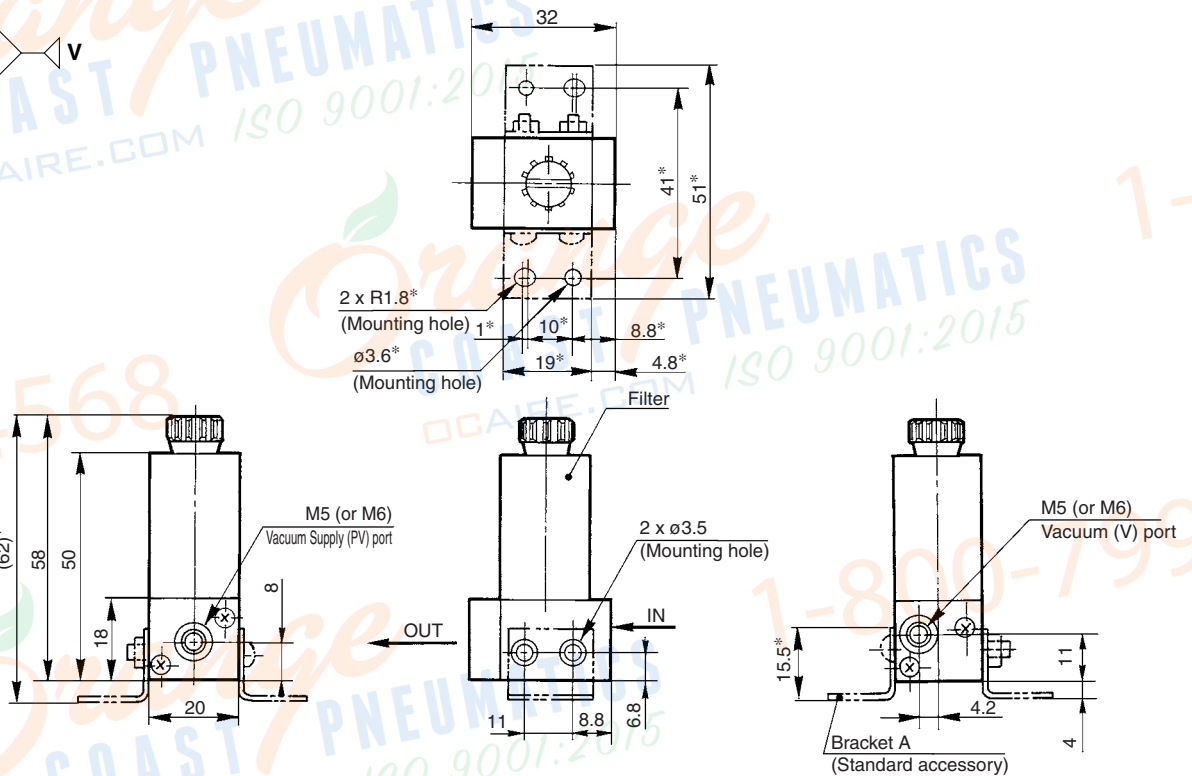
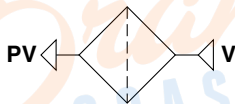

Note) Dimensions *: For A mounting bracket.

Filter case

⚠ Caution

- The case is made of polycarbonate. Therefore, do not use it with or expose it to the following chemicals: paint thinner, carbon tetrachloride, chloroform, acetic ester, aniline, cyclohexane, trichloroethylene, sulfuric acid, lactic acid, water-soluble cutting oil (alkalinic), etc.
- Do not expose it to direct sunlight.

About this product

The filter mounted on the product is a simplified one. When used in an environment with a lot of dust, the filter is likely to be clogged quickly. Select a large-volume filter such as Series ZFA.

Vacuum Pressure Switch Unit/Vacuum Pressure Switch: ZSE2-0X

Quick response: 10 ms

Compact size: 39H x 20W x 15D
(except the connecting portion
of the standard type)

Improved wiring: connector type

Uses a carrier diffusion
semiconductor pressure sensor

Pressure detector
(A carrier diffusion semiconductor
pressure sensor is used.)

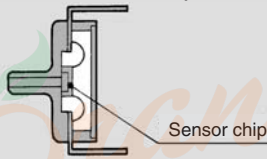

Vacuum Pressure Switch

Unit no.	ZSE2-0X
Fluid	Air
Set pressure range	0 to -101 kPa
Hysteresis	3% Full span or less
Repeatability	±1% Full span or less
Temperature characteristics	±3% Full span or less
Voltage	12 to 24 VDC (Ripple ±10% or less)
Port size	M5 x 0.8, M6 x 1 (Option)
Mass	50 g
Output	Open collector 30 V, 80 mA
Indicator light	Light at ON state
Current consumption	17 mA or less (24 VDC, at ON state)
Operating temperature range	0 to 60°C
Max. operating pressure	0.5 MPa *

* When using ejector system, instantaneous pressure up to 0.5 MPa will not damage the switch.
Note) If not operated within the specified range of pressure of temperature, trouble may result.

Wiring

ZSE2 connection

-15NPN Open collector

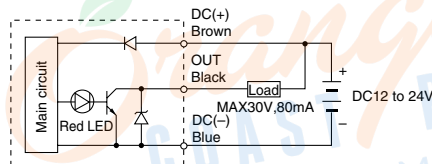

-55PNP Open collector

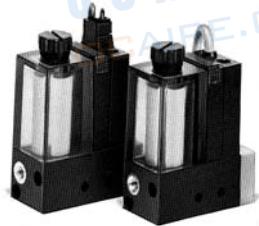
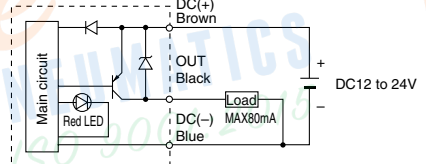

How to Order

ZSE2 - 0X [] - **15** [] []

PV, V port size

Nil	M5 x 0.8
Y	M6 x 1 (Option)

Electrical entry

Nil	Grommet (0.6 m)
L	Grommet (3 m)
C	Connector (0.6 m)
CL	Connector (3 m)
CN	Without connector

Output specifications

15	NPN Open collector 30 V 80 mA
55	PNP Open collector 30 V 80 mA

Filter case

⚠ Caution

1. The case is made of polycarbonate. Therefore, do not use it with or expose it to the following chemicals: paint thinner, carbon tetrachloride, chloroform, acetic ester, aniline, cyclohexane, trichloroethylene, sulfuric acid, lactic acid, water-soluble cutting oil (alkalinic), etc.

2. Do not expose it to direct sunlight.

Vacuum pressure setting

⚠ Caution

Observe the following precautions when setting the vacuum pressure.

Lightly turn the screwdriver with your fingertips.

To prevent damage to the trimmer groove, do not use a screwdriver that has a large grip or a tip that does not fit in the trimmer groove.

The filter mounted on the product is a simplified one. When used in an environment with a lot of dust, the filter on the unit is likely to be clogged quickly. Use with the ZFA, ZFB and ZFC series is recommended.

Refer to the pressure switch ZSE2 Series catalog for the detailed specifications of pressure switches.

How to Set Vacuum Pressure

ZSE2

- Pressure setting trimmer selects the ON pressure. Clockwise rotation increases high vacuum set point.

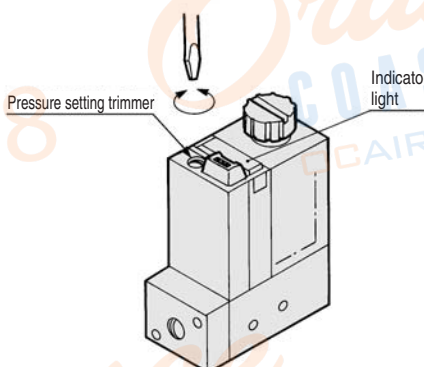

- When using the switch to confirm correct adsorption, the set pressure should be as low as possible. If setting the pressure lower than that, switch becomes ON in case when adsorption is not complete. If setting the pressure higher than that, switch does not become ON though it is absorbing workpieces properly.

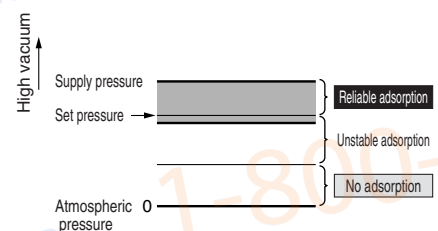

Vacuum Pressure Switch Unit/Vacuum Pressure Switch: ZSE2-0X

Guidelines for Use of Vacuum Pressure Switch Unit

System circuit for work adsorption

Ejector style

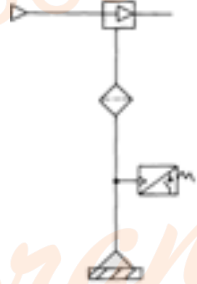

External vacuum supply style

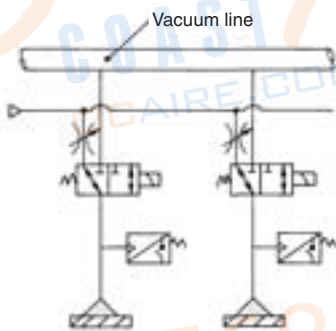

Set pressure

To use for picking verification, set a vacuum pressure that can pick the workpiece without fail.

Using a small diameter picking nozzle

If the nozzle diameter is approximately 1 mm, the adsorption confirmation with ZSE2/ZSE3 may not be possible since the pressure difference between ON and OFF becomes smaller. At times like this, consider using an adsorption confirmation switch, ZSP1 (page 879).

Note) Note that the performance of ejectors and pumps influence the conditions.

Using multiple pressure switches with a single vacuum source

If a single vacuum source is divided so that vacuum switches can be used on individual lines, the vacuum pressure might not come within the values set with the switches because the pressure of the vacuum source fluctuates depending on the number of picks and non-picks. Especially, because pressure fluctuation exerts a great influence when picking with a small diameter nozzle, the countermeasures described below must be provided.

Vacuum pressure reduction valve (Vacuum adjusting valve)

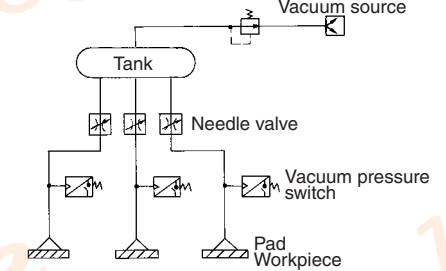

- Adjust the needle valve to reduce the pressure fluctuation between picking and non-picking.
- Stabilize the source pressure by providing a tank and a vacuum regulator.
- Provide a vacuum switch valve to individual lines. Thus, in case of an error, each valve can be turned OFF to minimize the influences on other pads.

External vacuum supply system

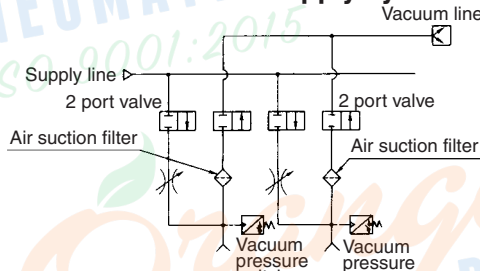

Vacuum Pressure Switch: ZSE2-0X-15₅₅

Grommet: ZSE2-0X-15₅₅

JIS Symbol

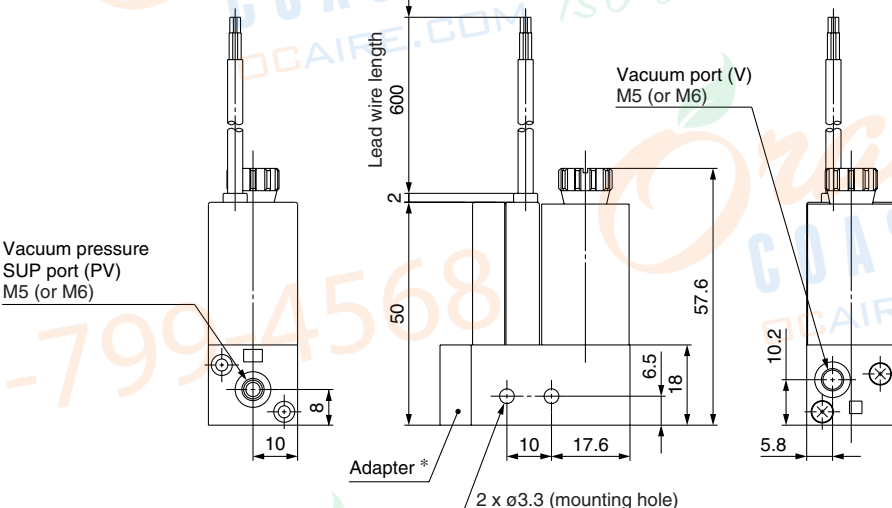
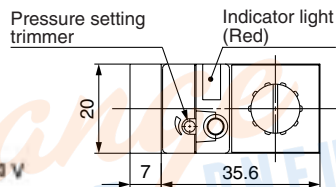
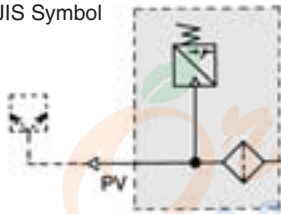

Connector: ZSE2-0X-15₅₅C

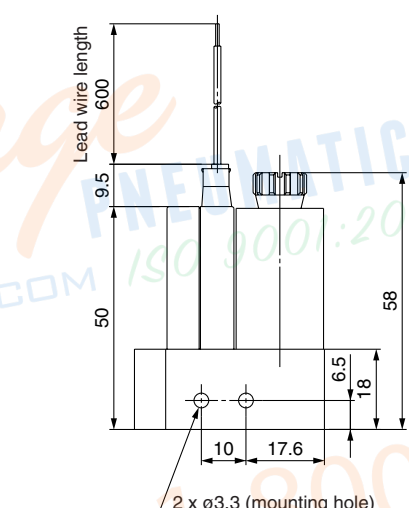
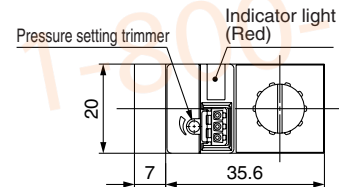

Vacuum Pressure Switch Unit/Vacuum Pressure Switch: ZSE3-0X

Built-in failure prediction output function

If the attainable amount of vacuum reduces due to a decrease in performance caused by clogging of the silencer of the vacuum system (ejectors), cracked pads, or the leakage of the vacuum pipes, this function quickly detects the abnormal condition and outputs a signal to halt the system.

Two independent pressure settings are possible

This feature is well suited for applications that require 2 separate pressure outputs due to a change in the vacuum suction pad diameters, or for applications that require 2 pressure verifications to effect line changes in the positive pressure line.

Comprehensive self diagnosis function

- Overcurrent detection function
- Overvoltage detection function
- Data error



LCD indication:
Error indicated on LCD
Operation indicator light:
Red light flashes during a malfunction

Data saving function

Even if the power is cut off, the settings are stored for 100,000 hours (approximately 11 years) in the exclusive IC (EEPROM).

• Filter case

⚠Caution

1. The case is made of polycarbonate. Therefore, do not use it with or expose it to the following chemicals: paint thinner, carbon tetrachloride, chloroform, acetic ester, aniline, cyclohexane, trichloroethylene, sulfuric acid, lactic acid, water-soluble cutting oil (alkalinic), etc.
2. Do not expose it to direct sunlight.

Vacuum Pressure Switch

Unit no.		ZSE3-0X
Fluid		Air
Set pressure range		0 to -101 kPa
Hysteresis	Hysteresis mode	Variable (Can be changed from 0)
	Window comparator mode	Fixed (3 digits)
Accuracy		±1% Full span or less
Operating voltage		12 to 24 VDC (Ripple ±10% or less)
Port size		M5 x 0.8, M6 x 1 (Option)
Mass		50 g
Indicator light		Light at ON state
Current consumption		25 mA or less
Operating temperature range		0 to 60°C
Max. operating pressure		0.5 MPa

Wiring

Wiring example

General connection method

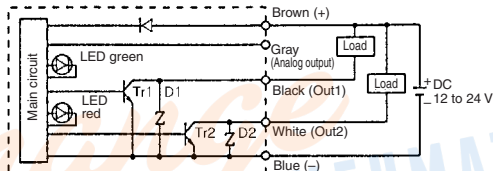

Connection with PLC

At negative COM terminal

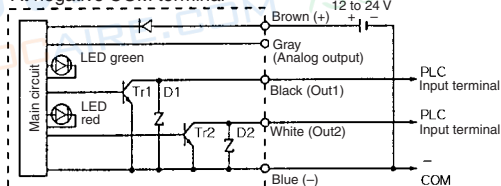

How to Order

ZSE3 - 0X [] - **21** []

PV, V port size

Nil	M5 x 0.8
Y	M6 x 1 (Option)

Output specifications

21	NPN open collector, double output Without analog output
22	NPN open collector, double output With analog output
23	NPN open collector 1 output/Trouble detection/ Without analog output
24	NPN open collector 1 output/Trouble detection/ With analog output

Wiring specifications

Nil	Grommet (0.6 m)
L	Grommet (3 m)
C	Connector (0.6 m)
CL	Connector (3 m)
CN	Without connector

Note) Analog output is available only for grommet type.

How to Set Vacuum Pressure

Refer to Best Pneumatics No. 6.

Guidelines for Use of Vacuum Pressure Switch Unit

Refer to page 876.

Vacuum Pressure Switch Unit/Vacuum Pressure Switch: ZSE3-0X

Vacuum Pressure Switch/ZSE3-0X□-21, 22, 23, 24

Grommet: ZSE3-0X□-□

Connector: ZSE3-0X□-□C

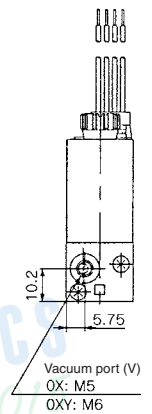
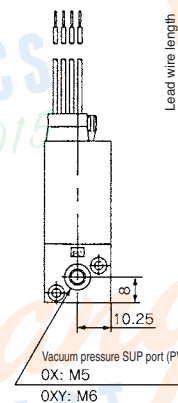
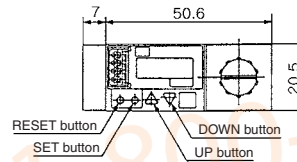
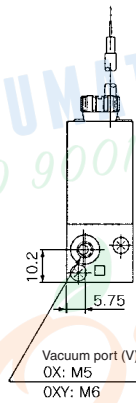
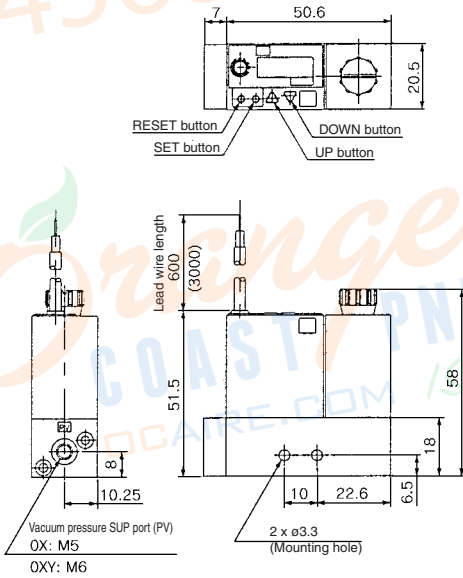

JIS Symbol

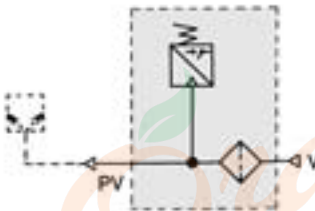

Vacuum Pressure Switch Unit/Adsorption Confirmation Switch: ZSP1-S_B

Small diameter nozzle/ø0.3 to ø1.2

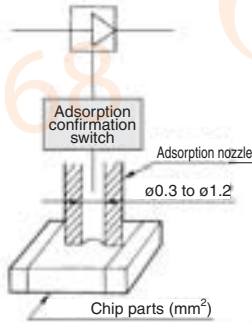

- With suction filter
- Improved wiring: connector type
- Uses a carrier diffusion semiconductor pressure sensor



• Filter case

Caution

- The case is made of polycarbonate. Therefore, do not use it with or expose it to the following chemicals: paint thinner, carbon tetrachloride, chloroform, acetic ester, aniline, cyclohexane, trichloroethylene, sulfuric acid, lactic acid, water-soluble cutting oil (alkalinic), etc.
- Do not expose it to direct sunlight.

• Other caution

Caution

It might not be possible to successfully pick a workpiece if a picking nozzle or a picking pad that is out of the applicable range is used.

The filter mounted on the product is a simplified one. When used in an environment with a lot of dust, the filter on the unit is likely to be clogged quickly. Use with the ZFA, ZFB and ZFC series is recommended.

Adsorption Confirmation Switch Specifications

Unit no.	ZSP1-S	ZSP1-B
Fluid	Air	
Operating pressure range	-20 kPa to -101 kPa	
Applicable adsorption nozzle dia.	0.3 to 0.7 mm (Refer to Graph (1).)	0.5 to 1.2 mm (Refer to Graph (2).)
Hysteresis	0.5 kPa	
Internal orifice	ø0.5	ø0.8
Mass	62 g	
Voltage	12 to 24 VDC (Ripple ±10% or less)	
Output	NPN Open collector 30 V 80 mA	
Indicator light	Light at ON state	
Current consumption	17 mA (24 VDC, at ON state)	
Operating temperature range	0 to 60°C (No condensation)	
Port size	M5 x 0.8, M6 x 1 (Option)	

Note) If not operated within the specified range of pressure and temperature, trouble may result.

Applicable Adsorption Nozzle

Supply pressure and nozzle diameter are expressed in the graphs below.

Graph (1)/ZSP1-S

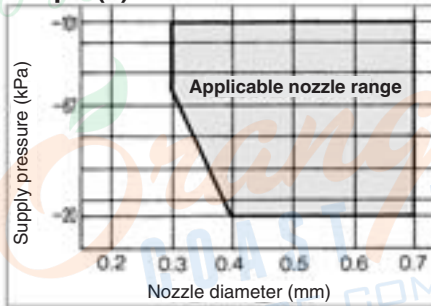

Graph (2)/ZSP1-B

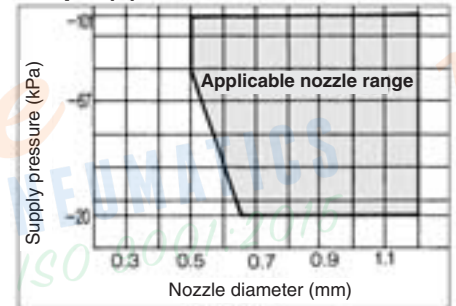

Pneumatic Circuit and Principle

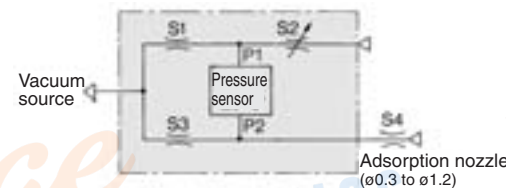

Comprised of a pneumatically operated bridge circuit, this function puts the S4 picking nozzle into the non-picking state, and uses the S2 adjustment needle to balance (P1 ≅ P2) the pressure that is applied to the pressure sensor. The small pressure difference (P2 - P1) that is created when a part is picked by the (S4) picking nozzle and is detected by the pressure sensor.

* Wiring is the same as ZSE2.

How to Order

ZSP1 - S 0X - 15

Symbol	Applicable model	PV, V port size	Piping specifications
S	Applicable nozzle dia. 0.3 to 0.7 mm	Nil	M5 x 0.8
B	Applicable nozzle dia. 0.5 to 1.2 mm	Y	M6 x 1 (Option)
			Nil
			L
			C
			CL

Circuit and Wiring

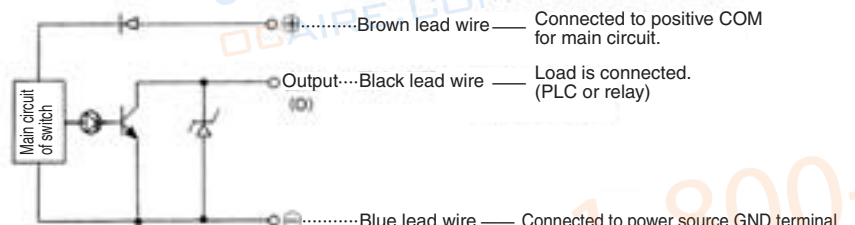

- ZA
- ZX
- ZR
- ZM
- ZMA
- ZQ
- ZH
- ZU
- ZL
- ZY□
- ZF□
- ZP□
- SP
- ZCUK
- AMJ
- AMV
- AEP
- HEP

Related Equipment

Vacuum Pressure Switch Unit/Adsorption Confirmation Switch: ZSP1-SB

Hysteresis

Hysteresis is the difference in pressure when the output signal is ON and OFF. The pressure to be set is the ON pressure.

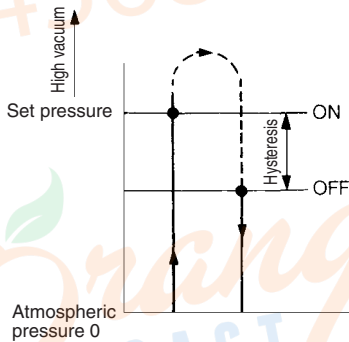

How to Set Adsorption Confirmation Needle

1. Apply a vacuum and current. Turn the adjusting needle clockwise until it stops, thus fully closing the needle valve.
2. Without attaching a workpiece to the picking nozzle, turn the adjusting needle counterclockwise and verify the position in which the indicator light turns ON.
3. From the state described in step 2, turn back the adjusting needle clockwise 1/4 turn to 1 full turn.
4. Pick a workpiece with the nozzle and readjust the adjusting needle so that the indicator light turns ON when the nozzle has picked the workpiece successfully.

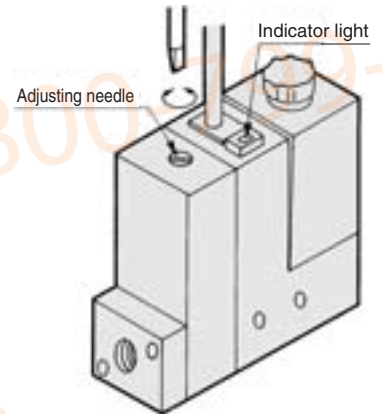
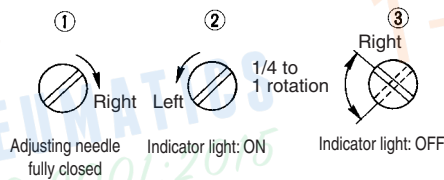

Adsorption Confirmation Switch: ZSP1-□0X□-15

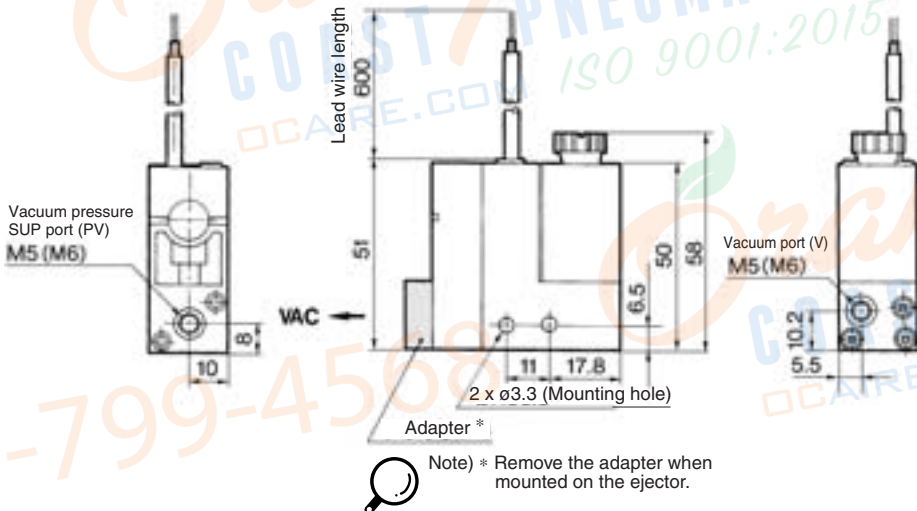
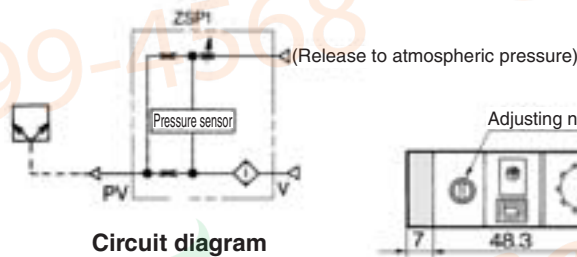

Note) * Remove the adapter when mounted on the ejector.

Connector: ZSP1-□0X□-15

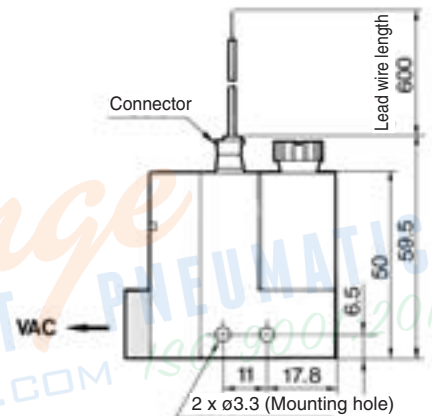
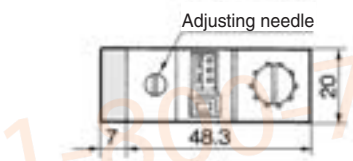

Without Valve Unit

Configuration and combination

Ejector unit +

Vacuum switch (ZSE2)

Adsorption confirmation switch (ZSP1)

Filter unit (F)

Model

ZX1□□□

E□

P□□

F

D□□□

Vacuum switch (ZSE2)

ZX1□□□-E□

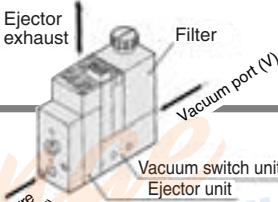

Circuit diagram

(Circuits other than those with vacuum switch are shown as below.)

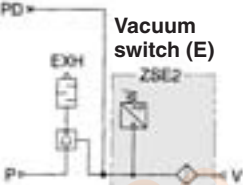

Adsorption confirmation switch (P)

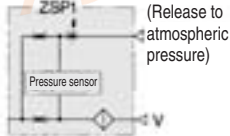

Filter unit (F)

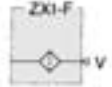

ZA

ZX

ZR

ZM

ZMA

ZQ

ZH

ZU

ZL

ZY□

ZF□

ZP□

SP

ZCUK

AMJ

AMV

AEP

HEP

Related Equipment

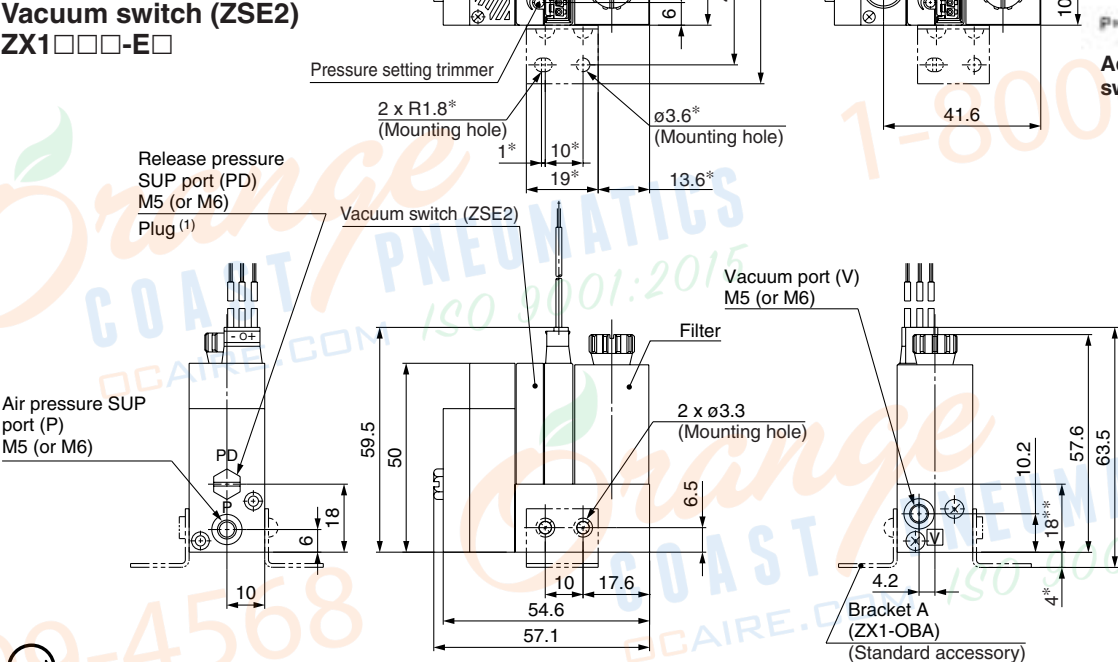

Note 1) Remove the plug at external release.

Note 2) Dimensions *: For mounting bracket A **: For mounting spacer 1.

Adsorption confirmation switch (ZSP1)

ZX1□□□-P□□

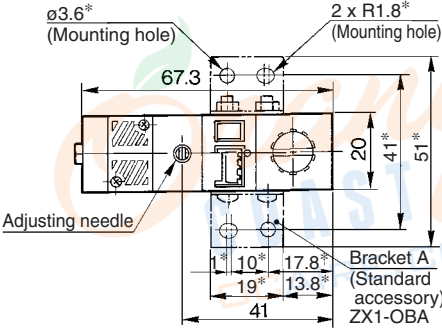

Filter unit (F)

ZX1□□□-F

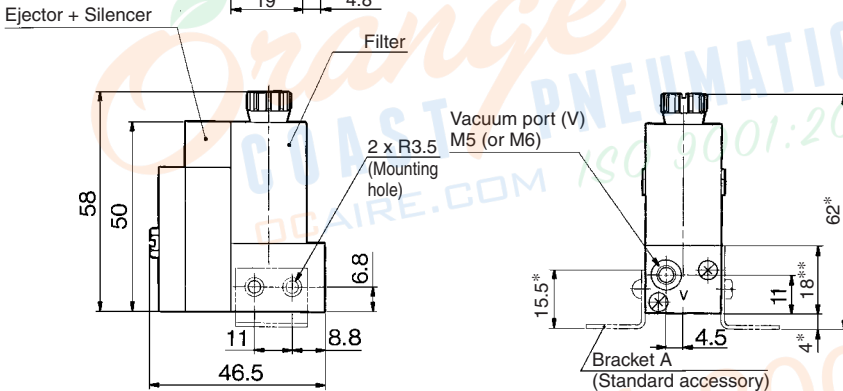
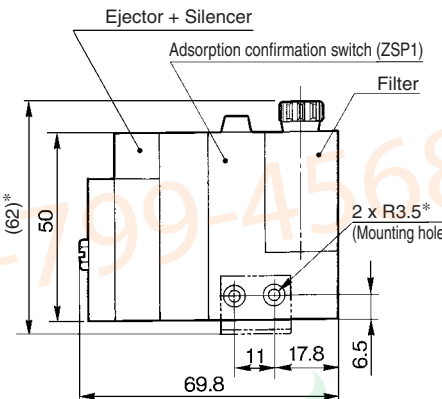
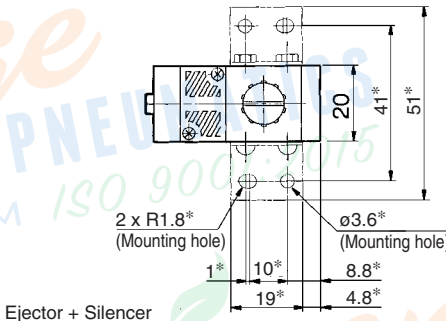

Series ZX

Valve Unit: Type K1

Configuration and combination

Ejector unit + Valve unit (K1) +

- Vacuum switch (ZSE2)
- Vacuum switch (ZSE3)
- Adsorption confirmation switch (ZSP1)
- Filter unit (F)
- Without switch and filter

Model

ZX1□□□□ — K1□□□□□ —

- E □
- D □□□
- P □□
- F □
- Nil

Vacuum switch (ZSE2)

ZX1□□□□-K1□□□□□-E□

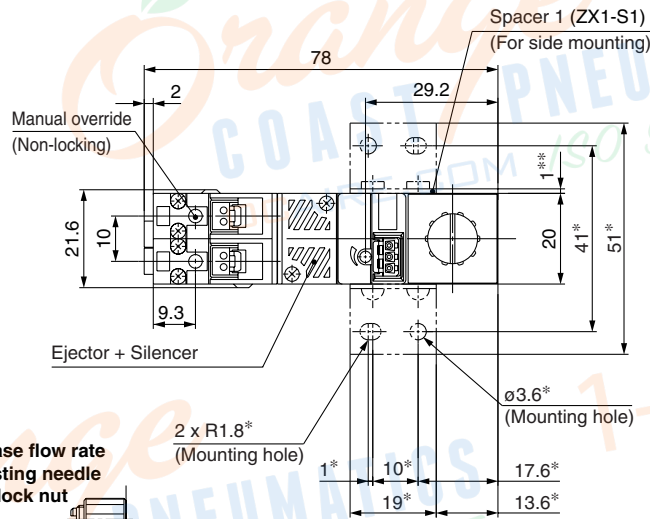
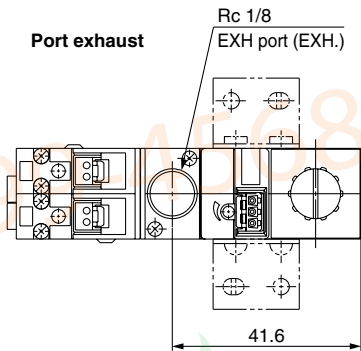

A: Release flow rate adjusting needle with lock nut

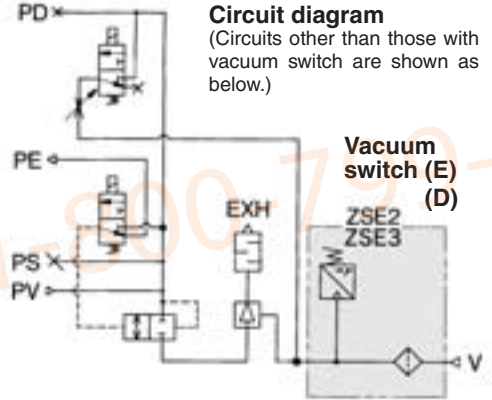
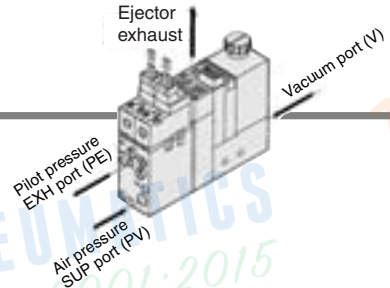
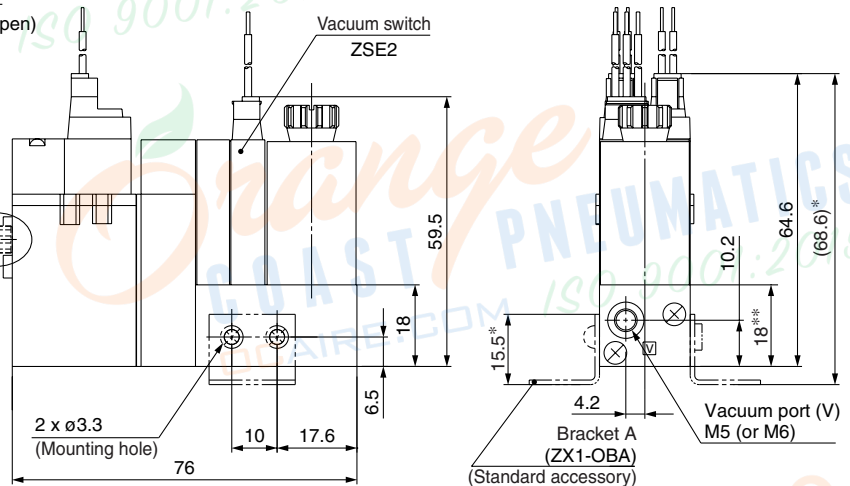
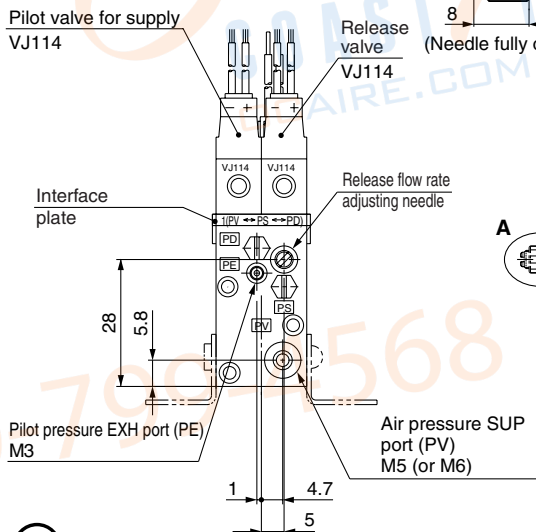
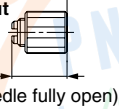

Circuit diagram

(Circuits other than those with vacuum switch are shown as below.)

Adsorption confirmation switch (P)

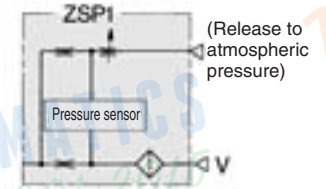

Filter unit (F)

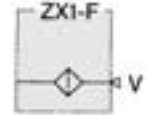

Without switch and filter



Vacuum switch (ZSE3)
ZX1□□□-K1□□□□-D□□□□

A: Release flow rate adjusting needle with lock nut

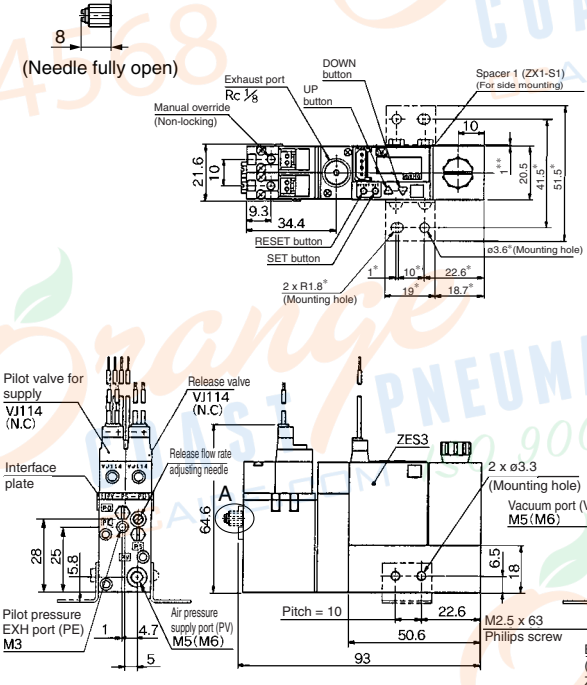

Adsorption confirmation switch (ZSP1)
ZX1□□□-K1□□□□-P□□□

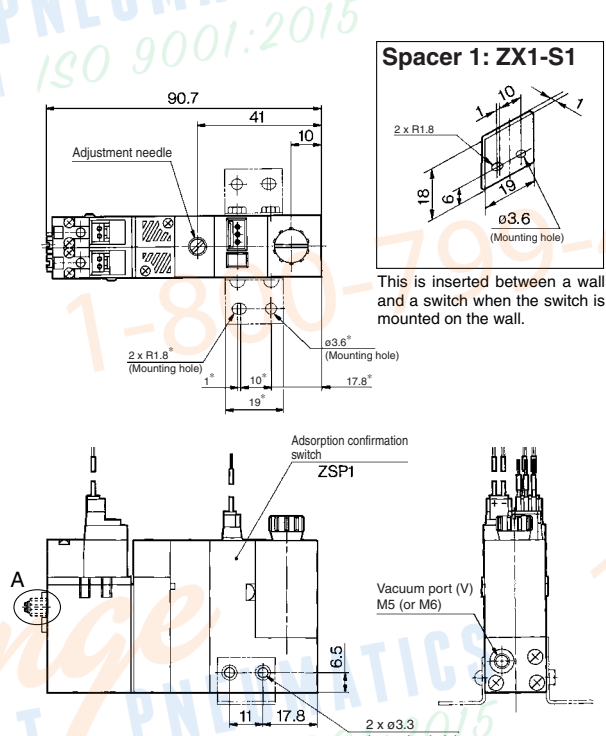

- ZA
- ZX**
- ZR
- ZM
- ZMA
- ZQ
- ZH
- ZU
- ZL
- ZY□
- ZF□
- ZP□
- SP
- ZCUK
- AMJ
- AMV
- AEP
- HEP
- Related Equipment

Filter unit
ZX1□□□-K1□□□□-F

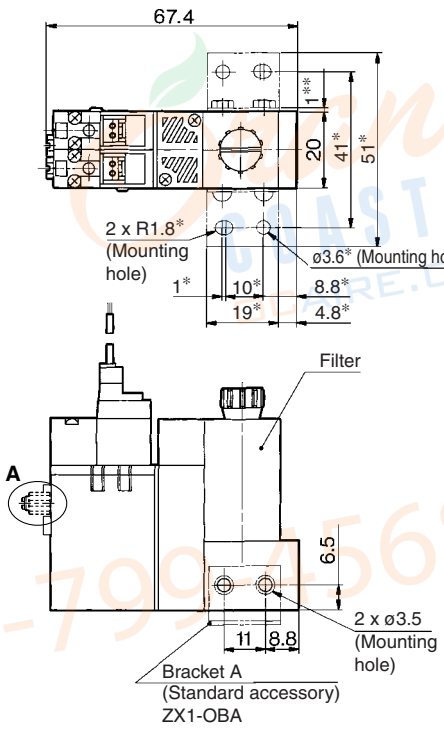

Without switch and filter
ZX1□□□-K1□□□□

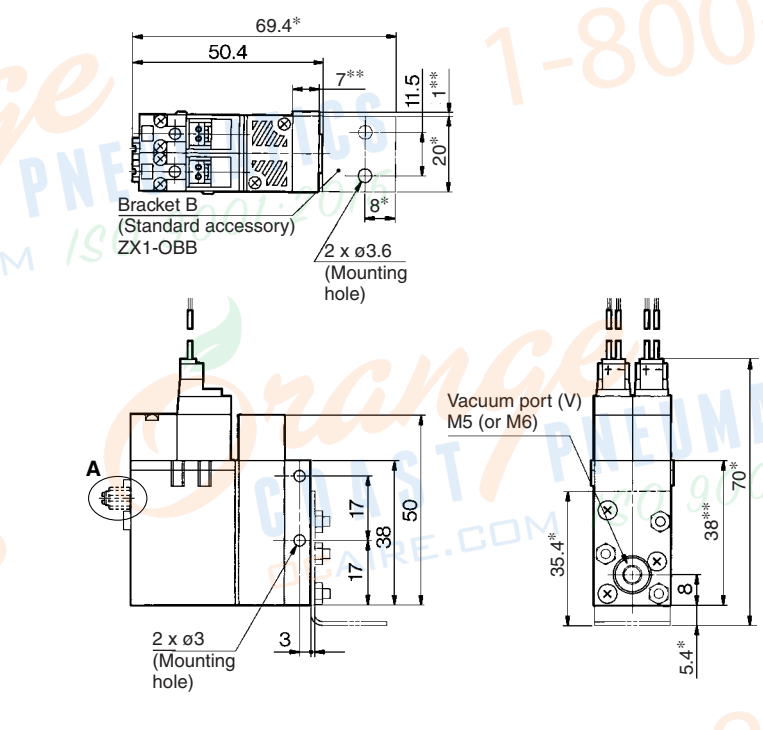

Series ZX

Valve Unit: Type K3

Configuration and combination

Ejector unit	+	Valve unit (K3)	+	Vacuum switch (ZSE2)
				Vacuum switch (ZSE3)
				Adsorption confirmation switch (ZSP1)
				Filter unit (F)
				Without switch and filter

Model

ZX1□□□ — K3□□□□ —

- E □
- P □
- F □
- D □
- Nil

Vacuum switch (ZSE2)

ZX1□□□-K3□□□□-E□

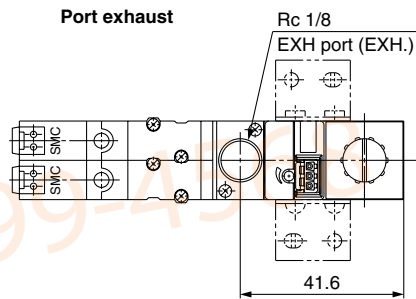

A: Release flow rate adjusting needle with lock nut

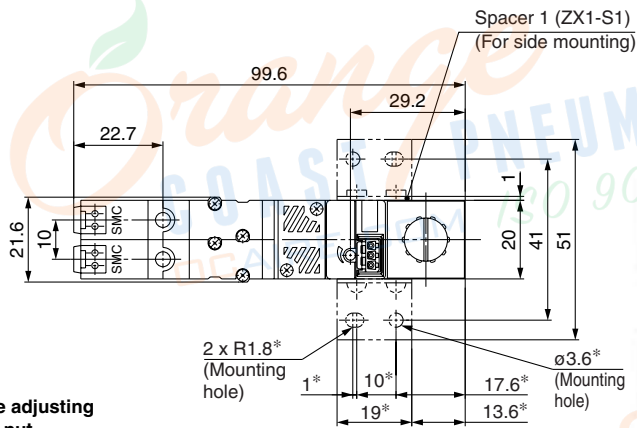
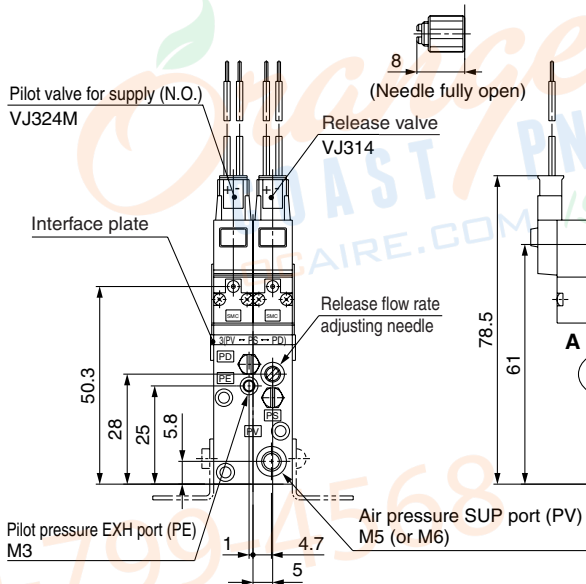

Filter unit (F)

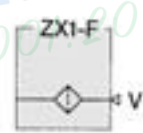

Without switch and filter

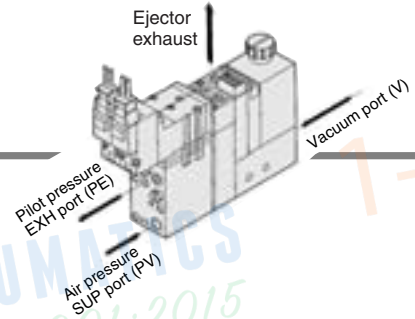

Circuit diagram

(Circuits other than those with vacuum switch are shown as below.)

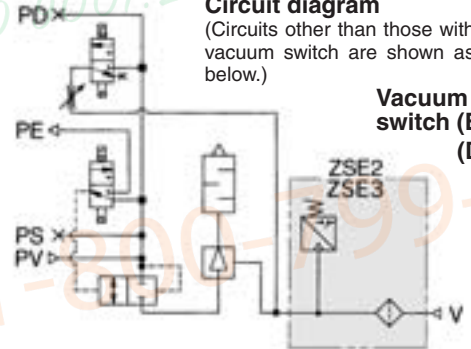

Vacuum switch (E) (D)

Adsorption confirmation switch (P)

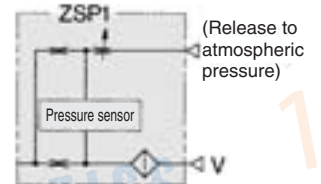

Note) Dimensions *: For mounting bracket A **: For mounting spacer 1.

Adsorption confirmation switch (ZSP1)
ZX1□□□-K3□□□□-P□□

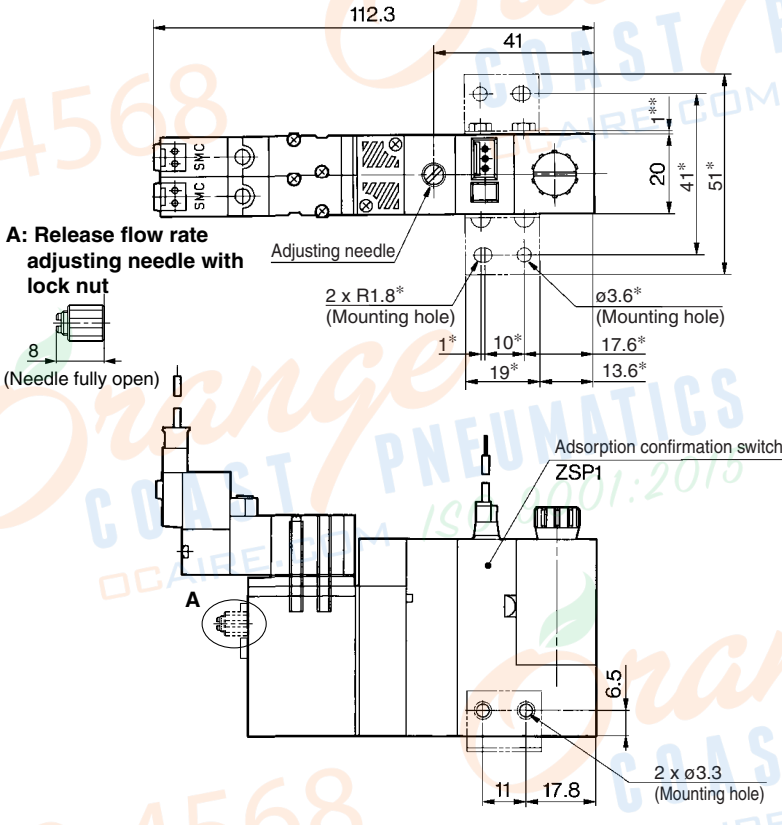

Spacer 1: ZX1-S1

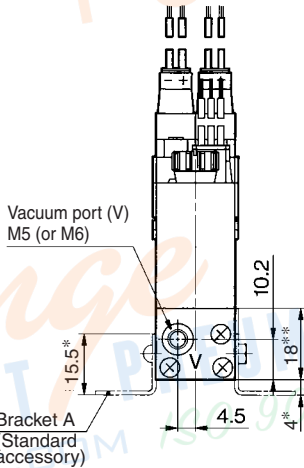
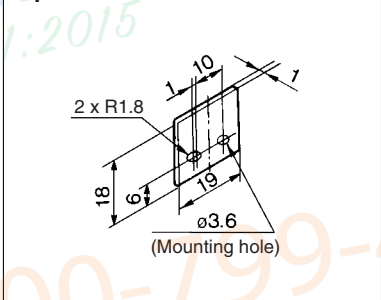

Filter unit (F)
ZX□□□□-K3□□□□-F

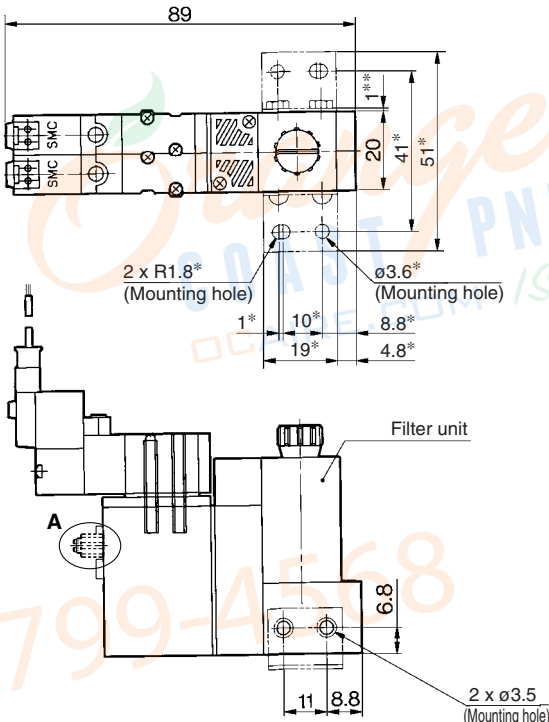

Without switch and filter
ZX1□□□□-K3□□□□

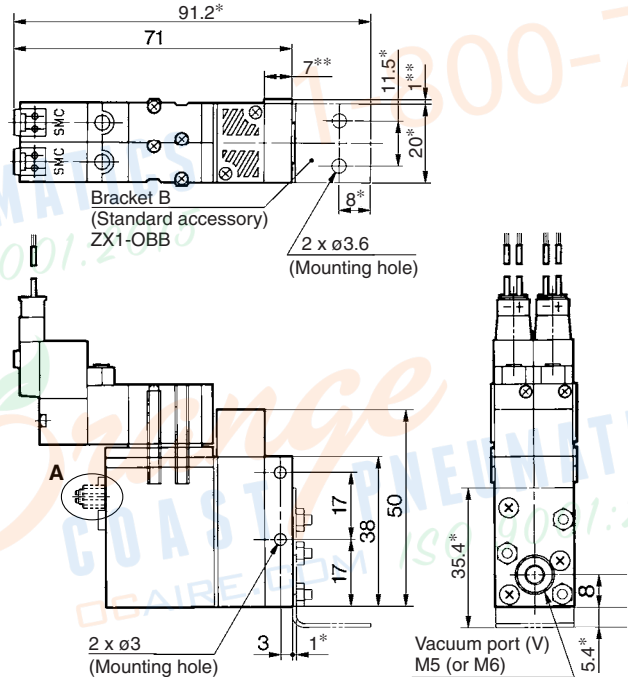

ZA
ZX
ZR
ZM
ZMA
ZQ
ZH
ZU
ZL
ZY□
ZF□
ZP□
SP
ZCUK
AMJ
AMV
AEP
HEP
Related Equipment

Series ZX

Valve Unit: Type K6

Configuration and combination

Ejector unit + Valve unit (K6)

- Vacuum switch (ZSE2)
- Vacuum switch (ZSE3)
- Adsorption confirmation switch (ZSP1)
- Filter unit (F)
- Without switch and filter

Model

ZX1□□□□ — K6□□□□ —

- E □
- P □□
- F □□□
- Nil

Vacuum switch (ZSE2)

ZX1□□□□ - K6-E□

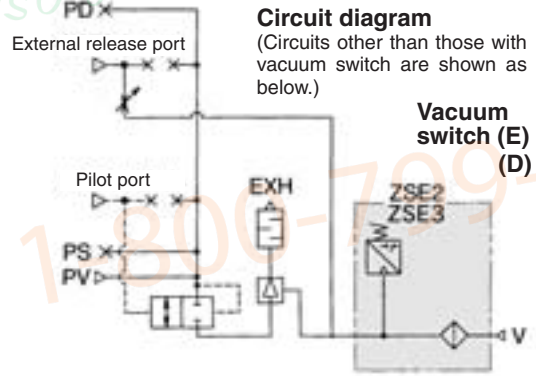
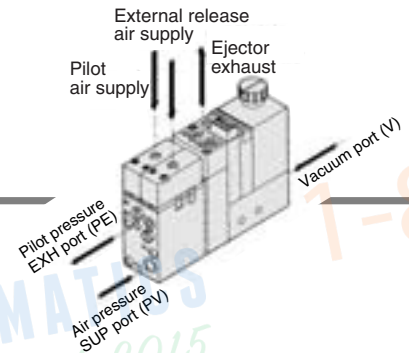

Circuit diagram

(Circuits other than those with vacuum switch are shown as below.)

Vacuum switch (E) (D)

Adsorption confirmation switch (P)

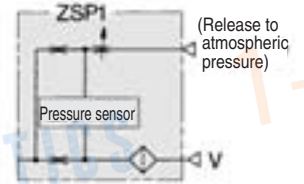

Filter unit (F)

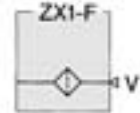

Without switch and filter



Port exhaust

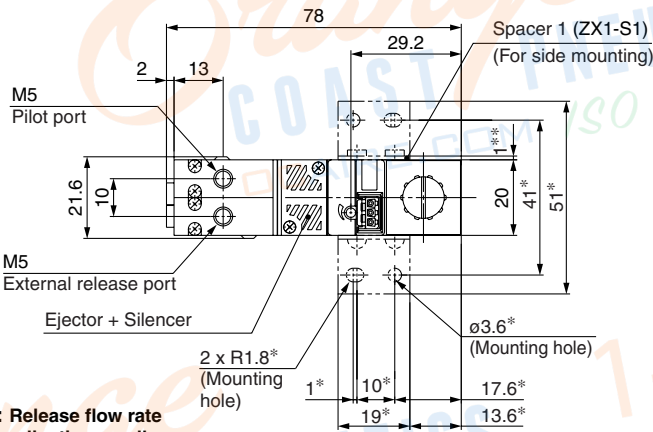
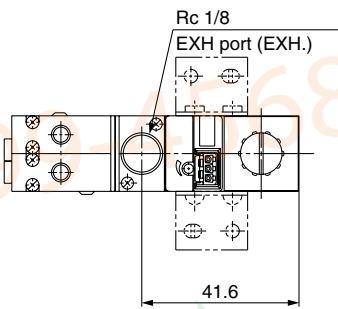

A: Release flow rate adjusting needle with lock nut

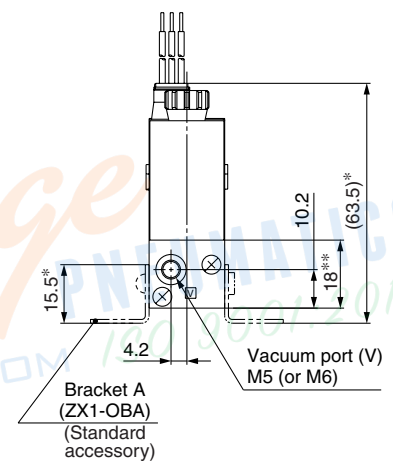
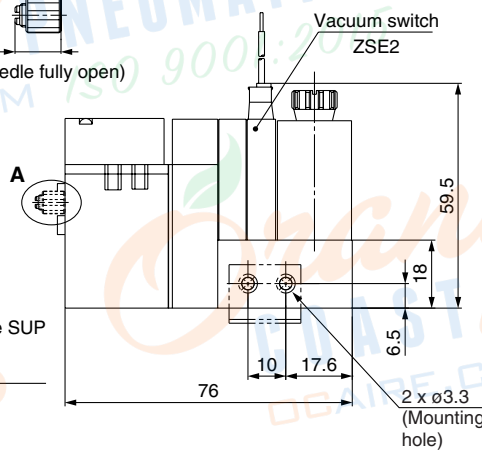
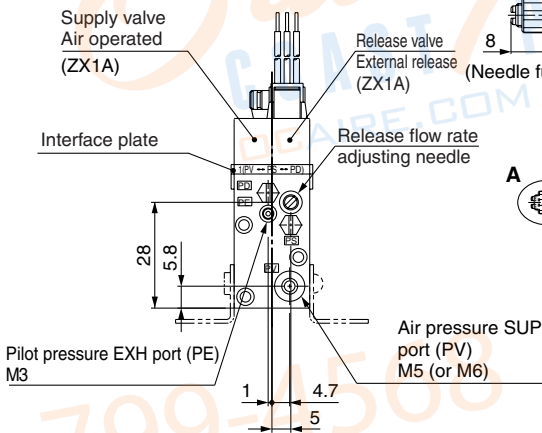

Note) Dimensions *: For mounting bracket B **: For mounting spacer 2.

Adsorption confirmation switch (ZSP1)
ZX1□□□-K6-P□□

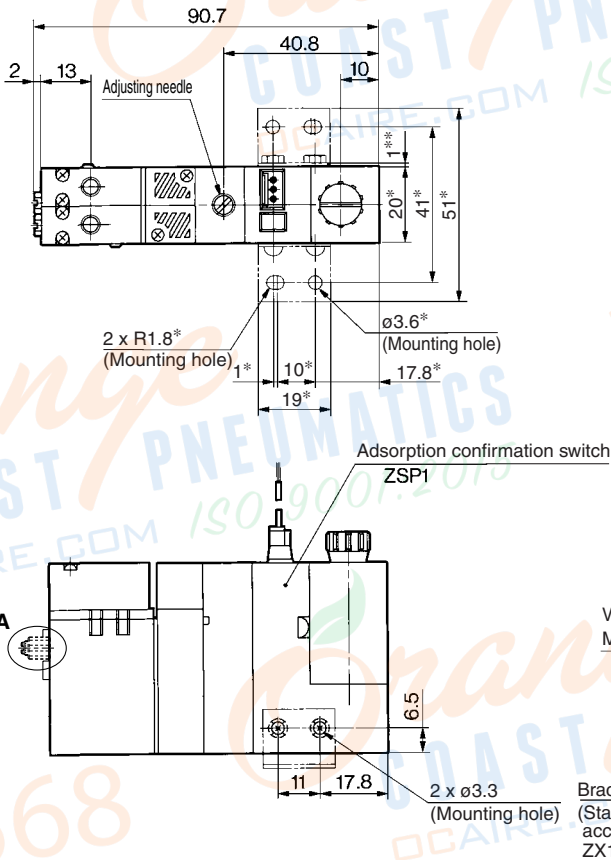

Spacer 1: ZX1-S1

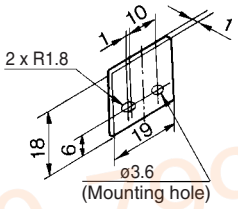

A: Release flow rate adjusting needle with lock nut with lock nut
(Needle fully open)

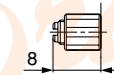

Filter unit (F)
ZX1-□□□-K6-F

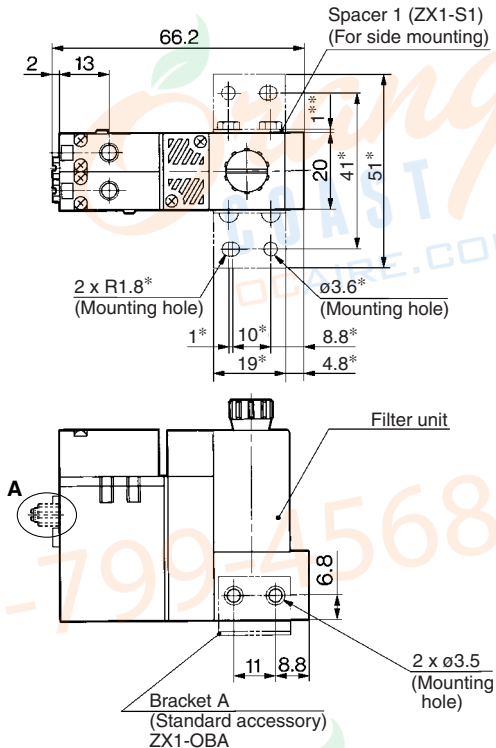

Without switch and filter
ZX1□□□-K6

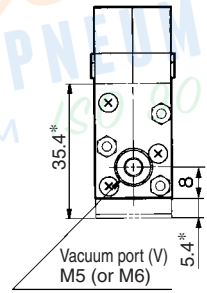
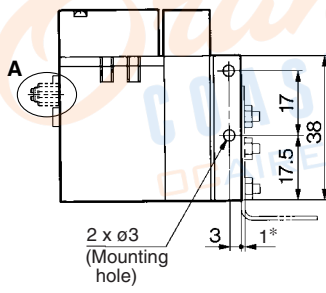
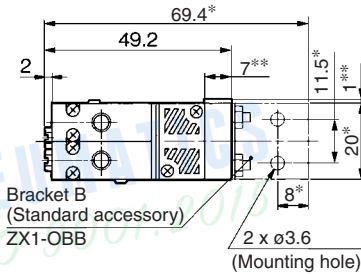

- ZA
- ZX**
- ZR
- ZM
- ZMA
- ZQ
- ZH
- ZU
- ZL
- ZY□
- ZF□
- ZP□
- SP
- ZCUK
- AMJ
- AMV
- AEP
- HEP
- Related Equipment

Series ZX

Valve Unit: Type K8

Configuration and combination

Ejector unit	+	Valve unit (K8)	+	Vacuum switch (ZSE2)
				Vacuum switch (ZSE3)
				Adsorption confirmation switch (ZSR1)
				Filter unit (F)
				Without switch and filter

Model

ZX1□□□ — K8 —

E □
 P □□
 F □□□
 D □□□
 Nil

Vacuum switch (ZSE2)
 ZX1□□□-K8-E□

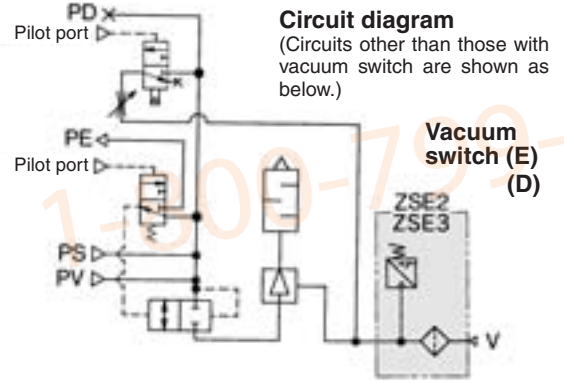
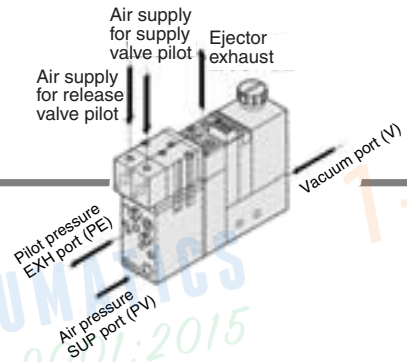

Vacuum switch (E)
 (D)

Adsorption confirmation switch (P)

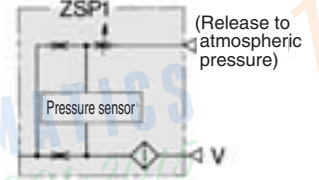

Filter unit (F)

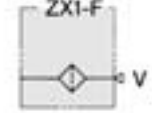

Without switch and filter

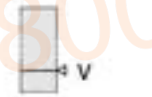

Port exhaust

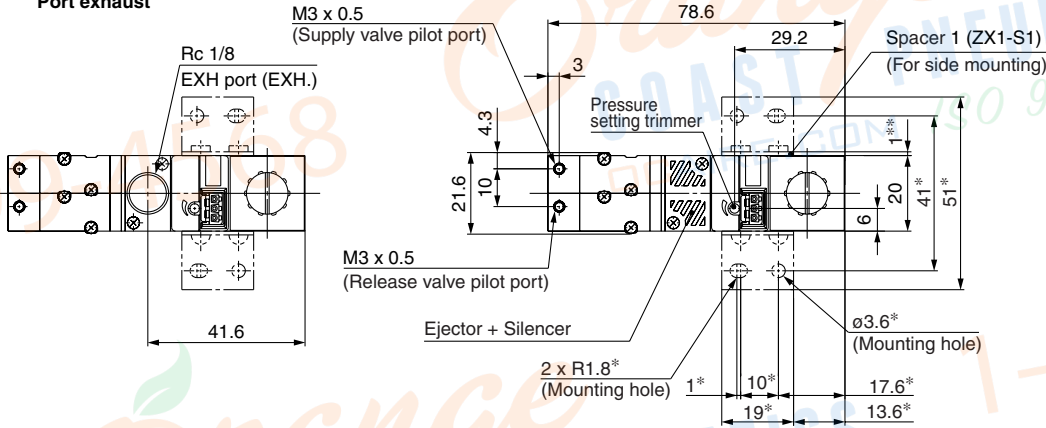

A: Release flow rate adjusting needle with lock nut

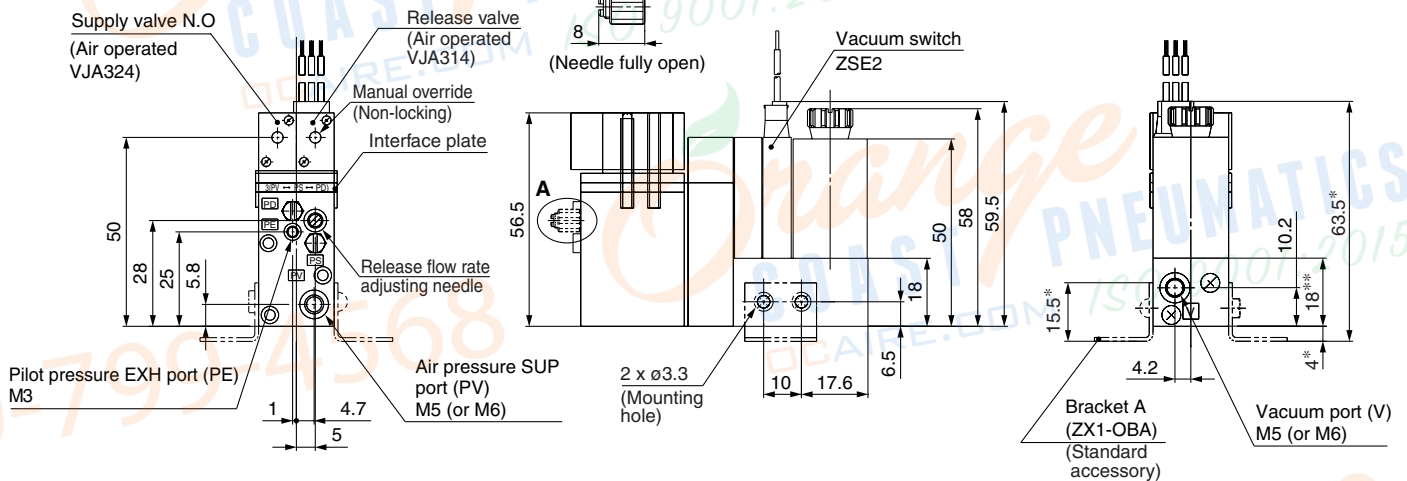

Note) Dimensions *: For mounting bracket A **: For mounting spacer 1.

Adsorption confirmation switch (ZSP1)
ZX1□□□-K8-P□□

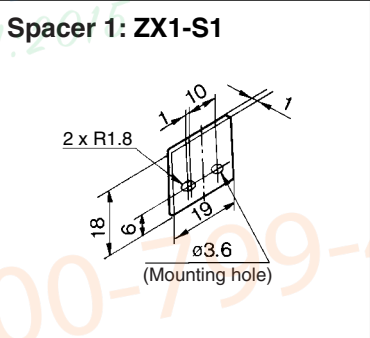
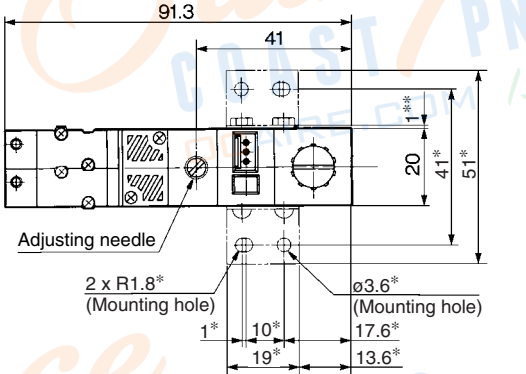

A: Release flow rate adjusting needle with lock nut

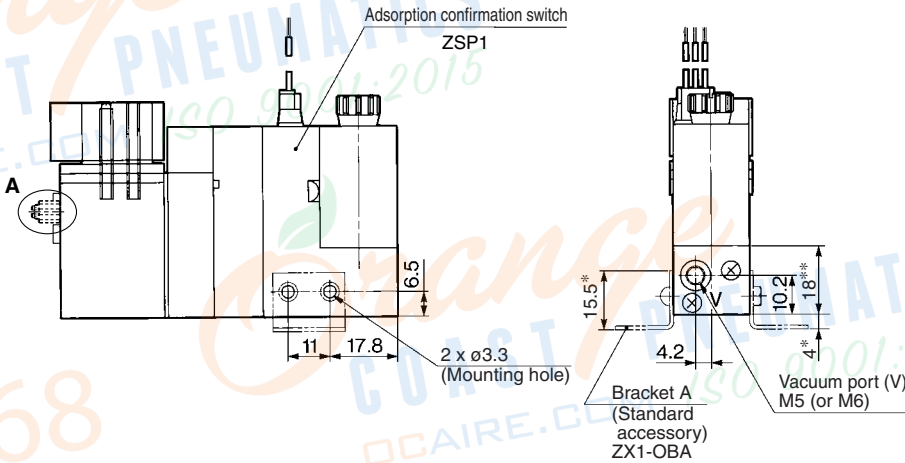
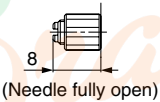

Filter unit (F)
ZX1□□□-K8-F

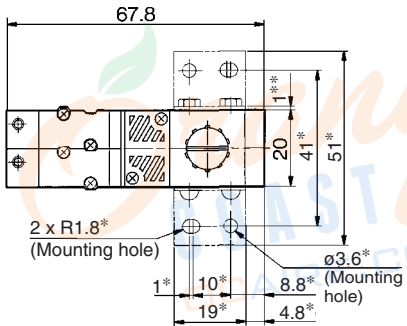

Without switch and filter
ZX1□□□-K8

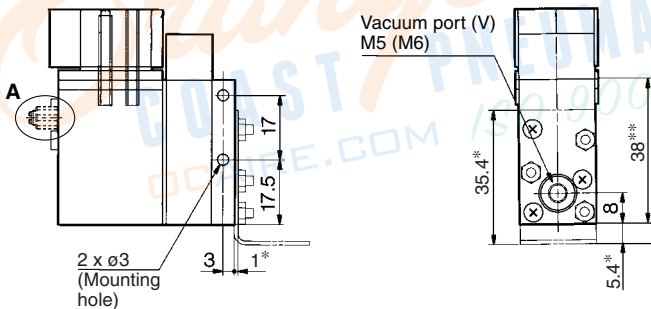
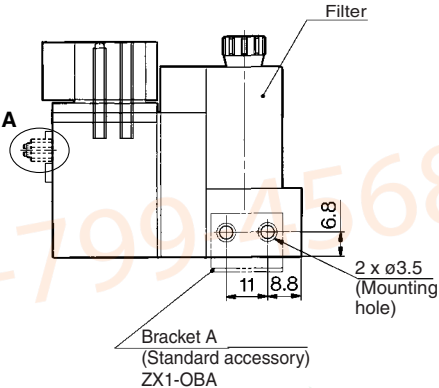
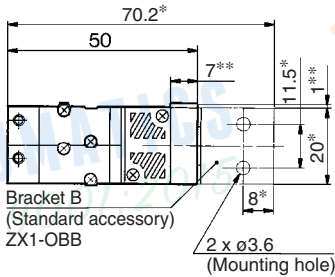

- ZA
- ZX**
- ZR
- ZM
- ZMA
- ZQ
- ZH
- ZU
- ZL
- ZY□
- ZF□
- ZP□
- SP
- ZCUK
- AMJ
- AMV
- AEP
- HEP
- Related Equipment

Series ZX

Valve Unit: Type J1

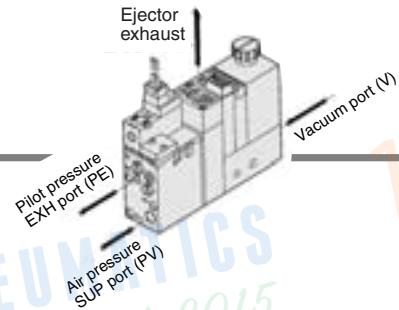

Configuration and combination Ejector unit + Valve unit (J1) +	Vacuum switch (ZSE2)
	Vacuum switch (ZSE3)
	Adsorption confirmation switch (ZSP1)
	Filter unit (F)
	Without switch and filter

Model

ZX1□□□ — J1□□□□ —

- E □
- P □ □
- F
- D □ □ □
- Nil

Vacuum switch (ZSE2)

ZX1□□□-J1□□□□-E□

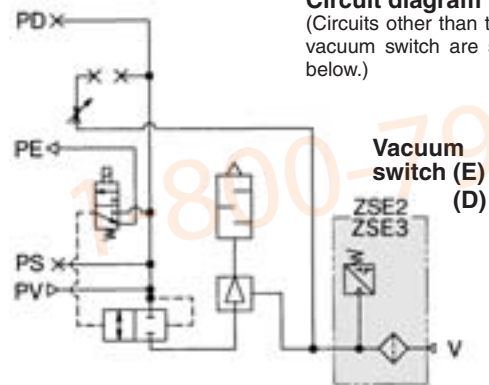

Circuit diagram

(Circuits other than those with vacuum switch are shown as below.)

Adsorption confirmation switch (P)

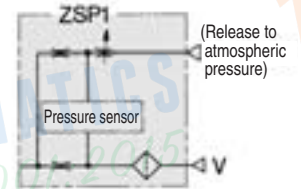

Filter unit (F)

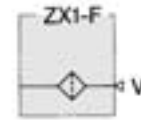

Without switch and filter

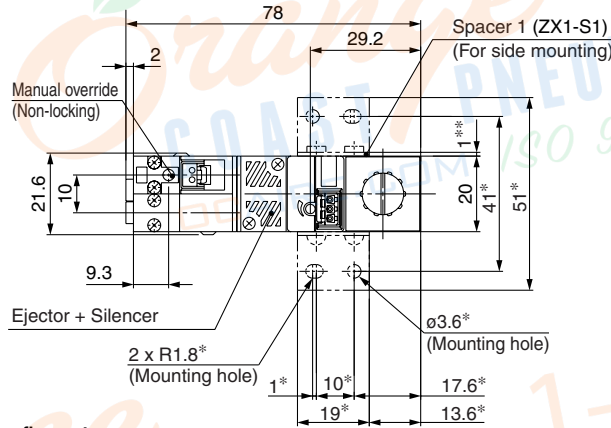
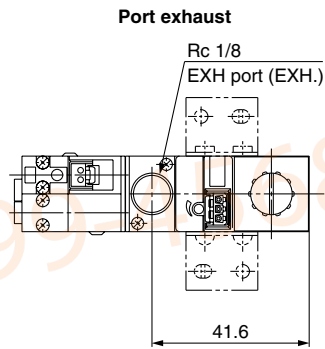

A: Release flow rate adjusting needle with lock nut

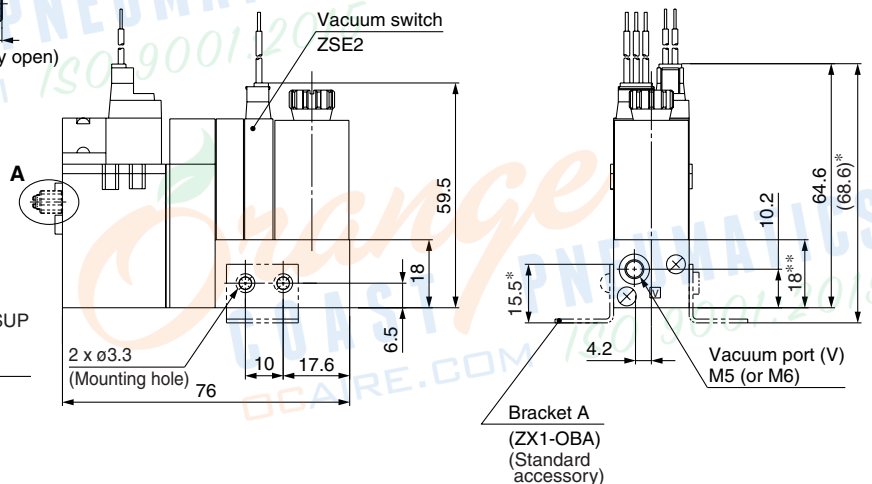
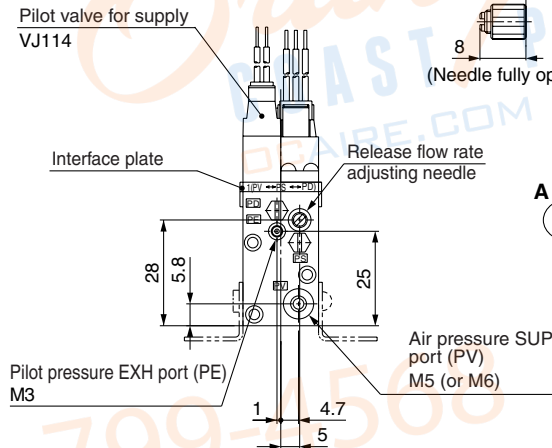
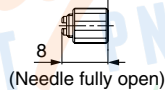

Note) Dimensions *: For mounting bracket A **: For mounting spacer 1.

Adsorption confirmation switch (ZSP1)
ZX1□□-J1□□□□-P□□

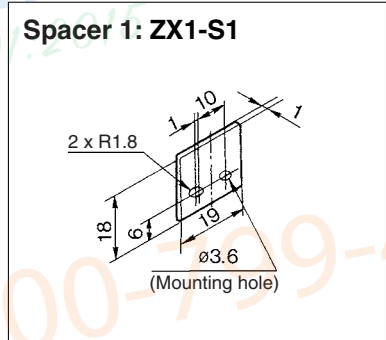
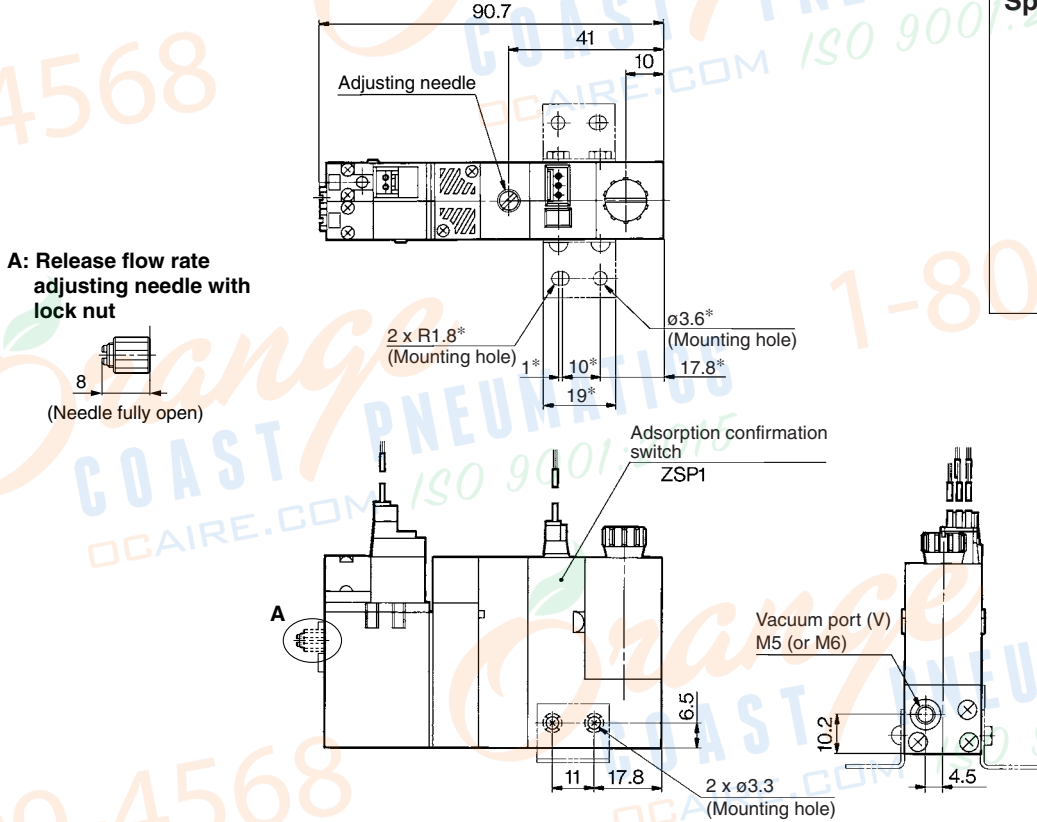

Filter unit (F)
ZX1□□□-J1□□□□-F

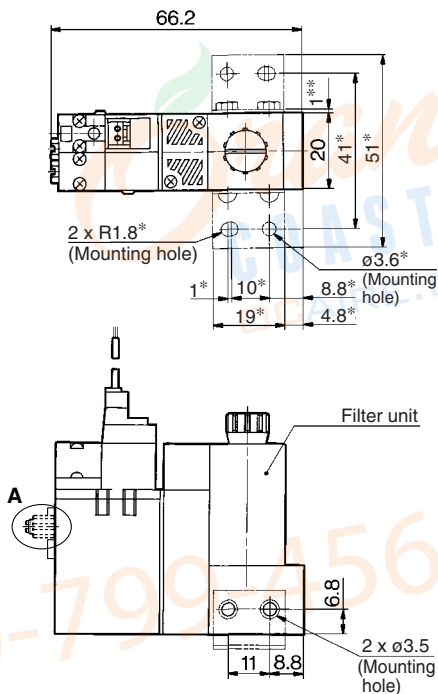

Without switch and filter
ZX1□□□-J1□□□□

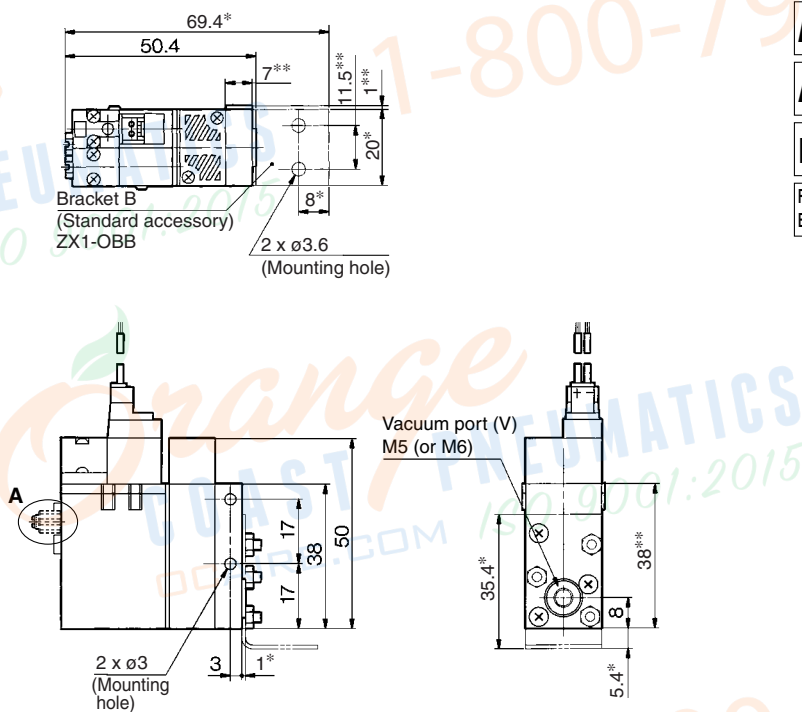

ZA
ZX
ZR
ZM
ZMA
ZQ
ZH
ZU
ZL
ZY□
ZF□
ZP□
SP
ZCUK
AMJ
AMV
AEP
HEP
Related Equipment

Adsorption confirmation switch (ZSP1)
ZX1□□□-J2□□□□-P□□

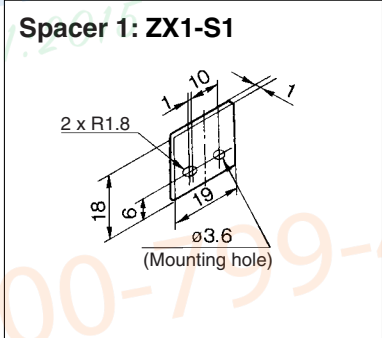
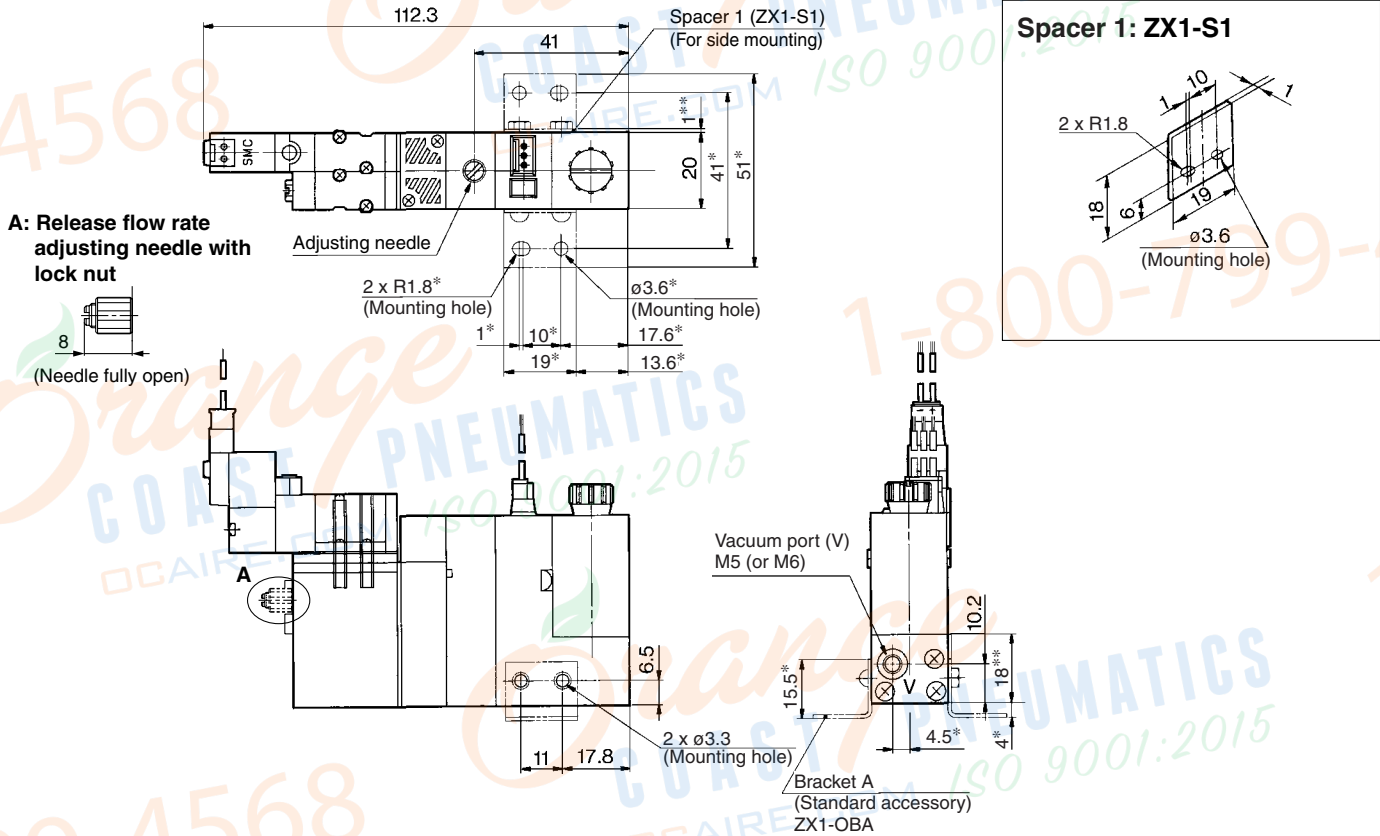

Filter unit (F)
ZX1□□□-J2□□□□-F

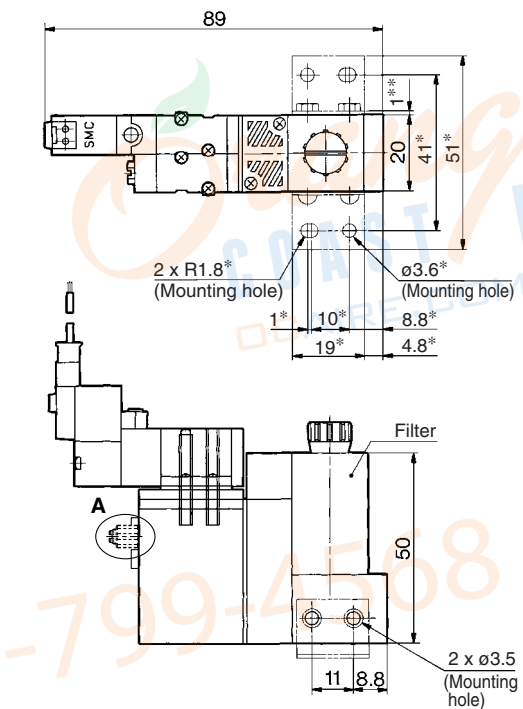

Without switch and filter
ZX1□□□-J2□□□□

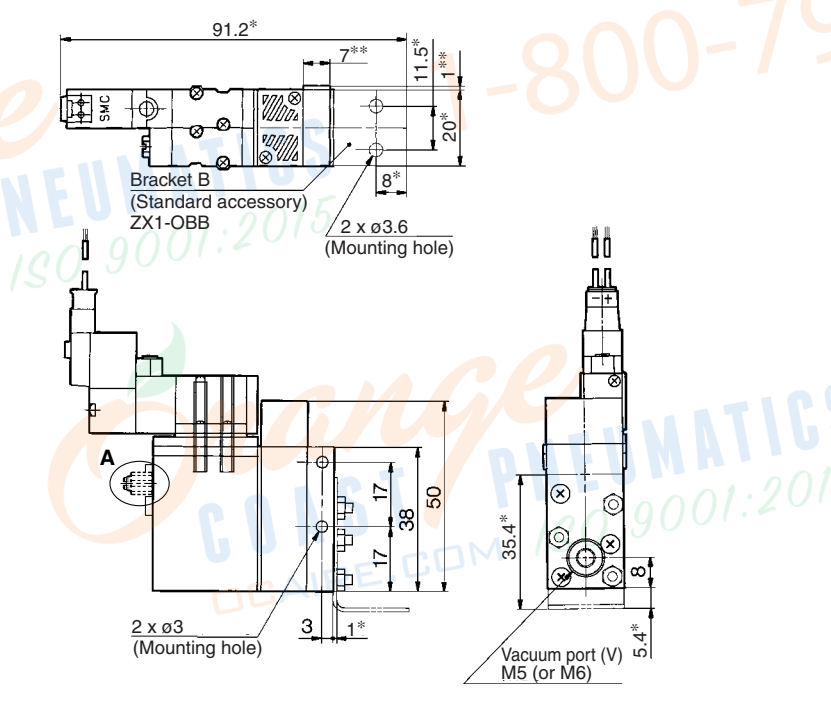

- ZA
- ZX**
- ZR
- ZM
- ZMA
- ZQ
- ZH
- ZU
- ZL
- ZY□
- ZF□
- ZP□
- SP
- ZCUK
- AMJ
- AMV
- AEP
- HEP
- Related Equipment

Ejector System/Manifold Specifications

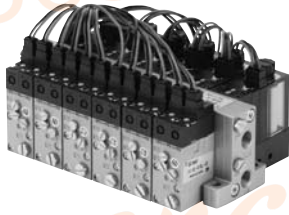
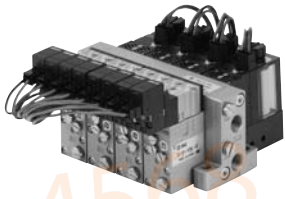

Specifications

Max. number of units		Max. 8 units
Port size	Supply port [PV]	1/8 (Rc, NPT, G)
	Exhaust port [EXH]	1/8 (Rc, NPT, G)
Mass		1 station: 73 g (50 g per additional station)

Note 1) PD port: Blank

Note 2) Exhaust air from both sides for 4 or more stations of ZX1103 manifold.

Air Supply

Supply port location	Manifold		Left side		Right side	
	Port		PV	PS	PV	PS
L (Left)			○	●	●	●
R (Right)			●	●	○	●
B (Both sides)			○	●	○	●

○: Supply ●: Plugged (EXH port is released to atmospheric pressure.)

Note) Blank plugs are attached to all ports of each valve unit.

How to Order Manifold

<Manifold base>

ZZX1 06 - [] R

Stations

01	1
02	2
⋮	⋮
08	8

Thread of supply and exhaust port

Nil	Rc
F	G (Note)
T	NPTF

Note) G thread

The thread ridge shape is compatible with the G thread standard (JIS B0202), but other shapes are not conforming to ISO16030 and ISO1179.

(Ordering example)

ZZX106-R.....1 pc. (Manifold base)

*ZX1101-K15LZ-EC(-Q).....5 pcs. (Vacuum single unit)

*ZX1-BM1.....1 pc. (Blank plate)

Supply port location ^(*)

R	Right side (PV port on the right side)
L	Left side (PV port on the left side)
B	Both sides (PV port on both sides)

*1 Viewed from the front side of valve unit, confirm the port location on the right and/or left side.

*2 EXH ports are released to atmospheric pressure in both sides.

Plugs are always attached to PD ports and all ports of the valve unit.

<Individual spacer>

Specify the individual spacer when separating the supply and exhaust ports of the manifold ejector.

ZX1 - R1 - 1

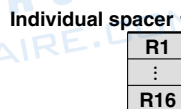

*Refer to the individual spacer.

(Ordering example)

If installed on station 1 and station 3:

ZZX106-R1 pc.

*ZX1101-K15LZ-EL(-Q)6 pcs.

*ZX1-R1-1

*ZX1-R1-3

*ZX1-R16 (Dummy spacer)4 pcs.

Arrangement

(First station from the right end of the valve side is station 1.)

Nil	All stations
1	Station 1 only
⋮	⋮
8	Station 8 only

*When spacers are mounted alternately, specify them together.

*When retrofitting, 3 pcs. of M2.5 x 32 (for ZX) are necessary. A dummy spacer (ZX1-R16) must be mounted on the stations on which individual spacers are not mounted.

About individual spacers

• Manifold supply or valve unit supply can be selectable for each port. In the table below, ports with the symbol ↓ mean that they are manifold supply, while others are individual supply from the valve unit.

• Symbols in the table below are printed on the surface of individual spacers.

No.	Symbol	No.	Symbol
ZX1-R1	R1	ZX1-R 9	R 9 ↓ PV
R2	R2 ↓ PE	R10	R10 ↓ PV ↓ PE
R3	R3 ↓ PD	R11	R11 ↓ PV ↓ PD
R4	R4 ↓ PD ↓ PE	R12	R12 ↓ PV ↓ PD ↓ PE
R5	R5 ↓ PS	R13	R13 ↓ PV ↓ PS
R6	R6 ↓ PS ↓ PE	R14	R14 ↓ PV ↓ PS ↓ PE
R7	R7 ↓ PS ↓ PD	R15	R15 ↓ PV ↓ PS ↓ PD
R8	R8 ↓ PS ↓ PD ↓ PE	R16	R16 ↓ PV ↓ PS ↓ PD ↓ PE

⚠ Caution when ordering manifold

The asterisk denotes the symbol for assembly. Prefix it to the ejector part numbers to be mounted. When it is not added, the manifold base and ejector are shipped separately.

Manifold/System Circuit Example

When not using individual spacer

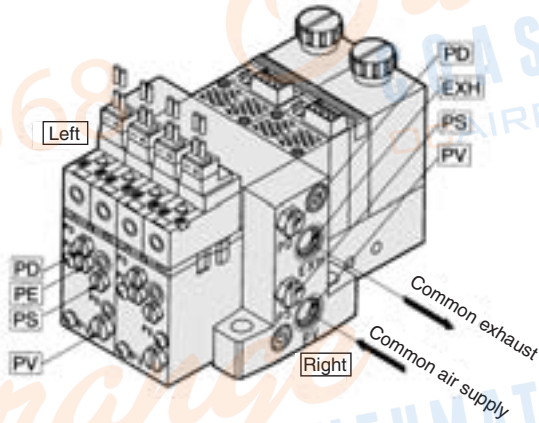

PV: Air pressure SUP port
 PS: Pilot pressure SUP port
 PD: Release pressure SUP port
 PE: Pilot pressure EXH port
 EXH: Common EXH port

When using individual spacer
 (When using ZX1-R1)

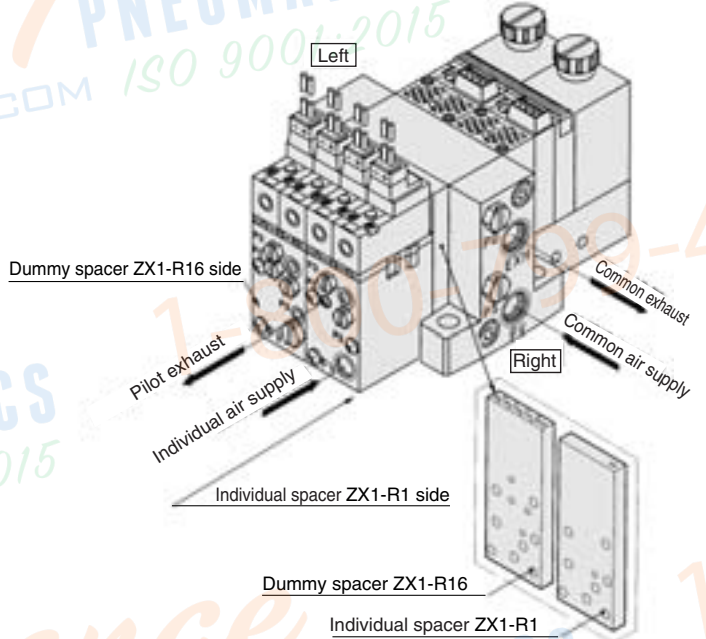

- ZA
- ZX**
- ZR
- ZM
- ZMA
- ZQ
- ZH
- ZU
- ZL
- ZY□
- ZF□
- ZP□
- SP
- ZCUK
- AMJ
- AMV
- AEP
- HEP

Related Equipment

<System circuit example>

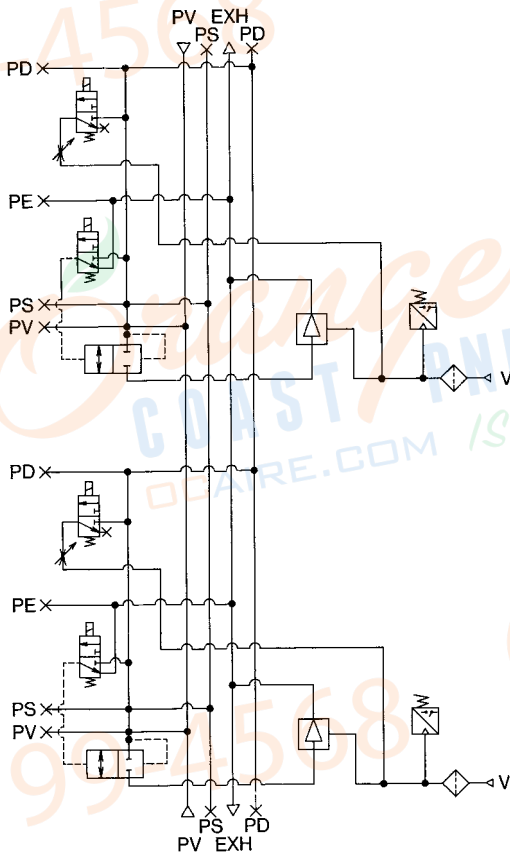

<System circuit example>

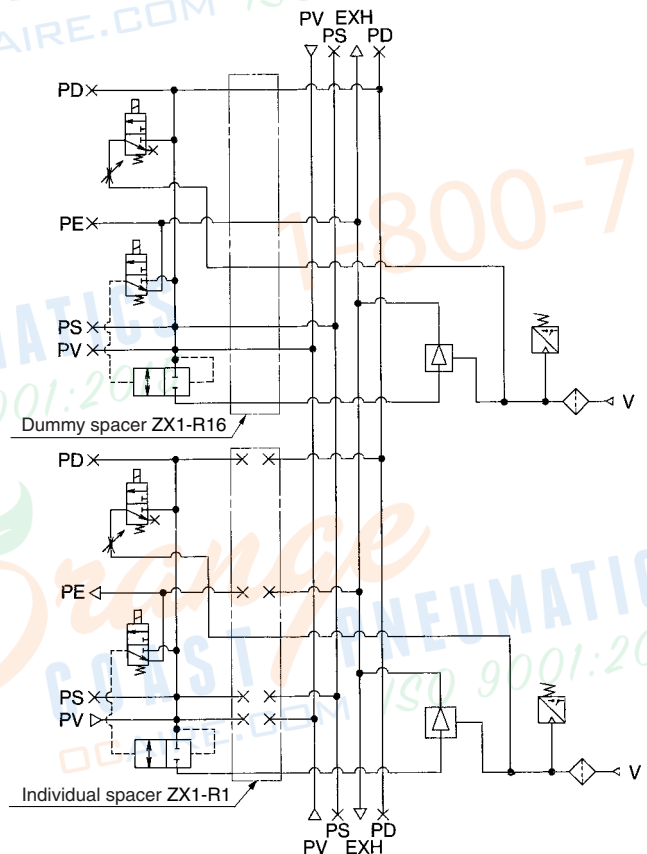

Series ZX

Ejector System Manifold

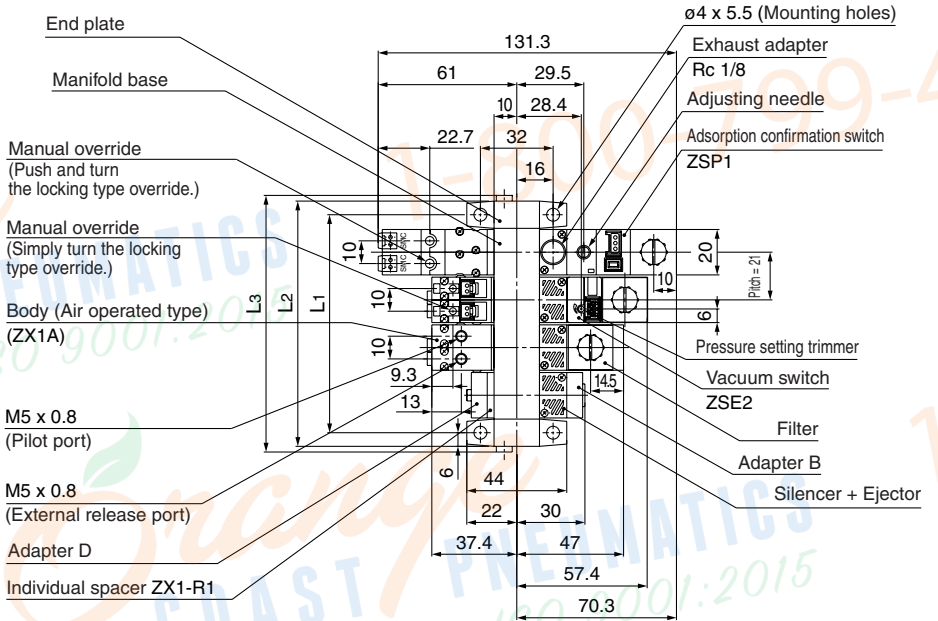
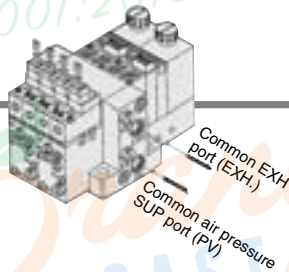

A: Release flow rate adjusting needle with lock nut

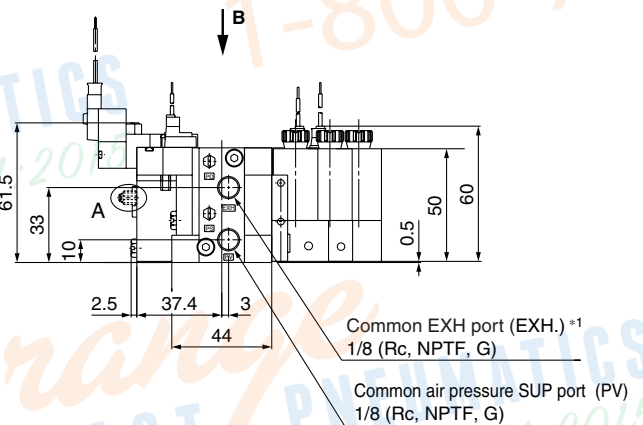
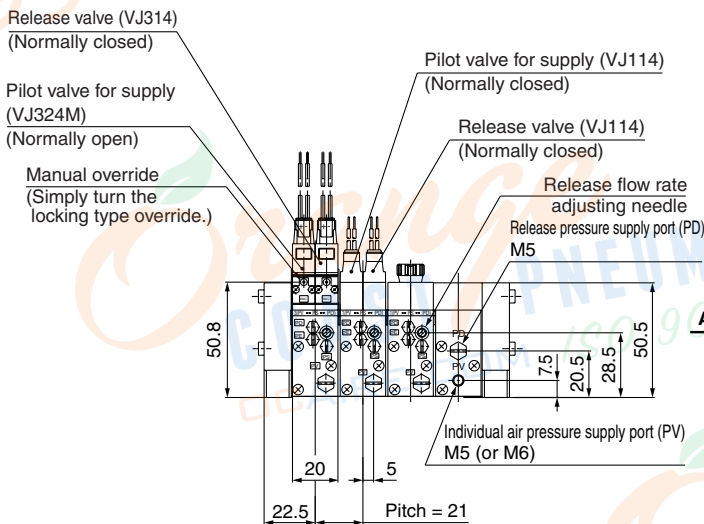
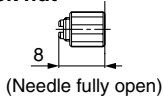

*1 The common exhaust port (EXH.) is also used as the pilot pressure exhaust (PE) port of pilot valve. Use while the port is open to the atmosphere.

		(mm)							
Symbol	Stations	1	2	3	4	5	6	7	8
L1		33	54	75	96	117	138	159	180
L2		45	66	87	108	129	150	171	192
L3		50	71	92	113	134	155	176	197

(In the case of individual spacer)

System circuit example

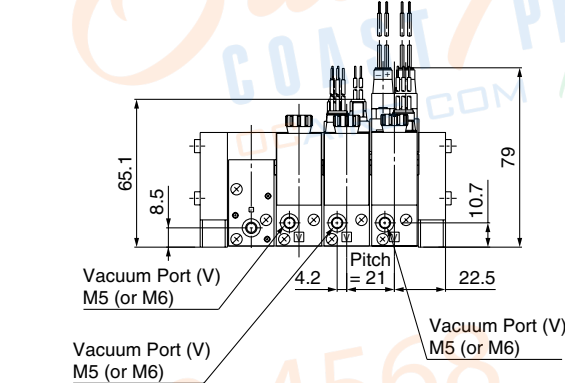
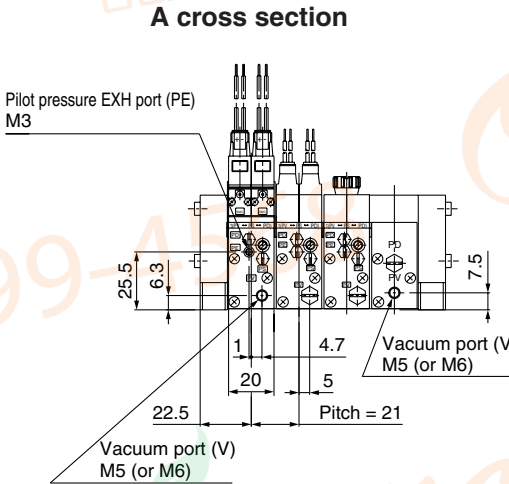
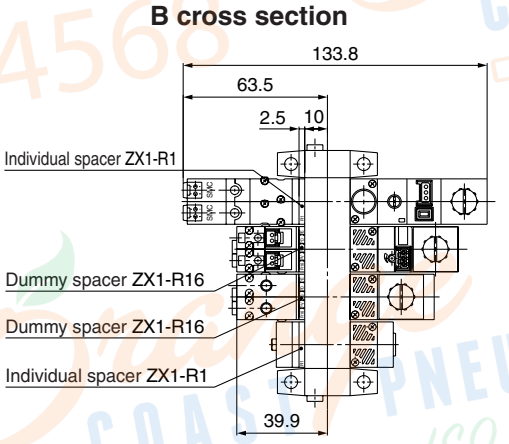

(Standard)

(Option)

(In the case of individual spacer)

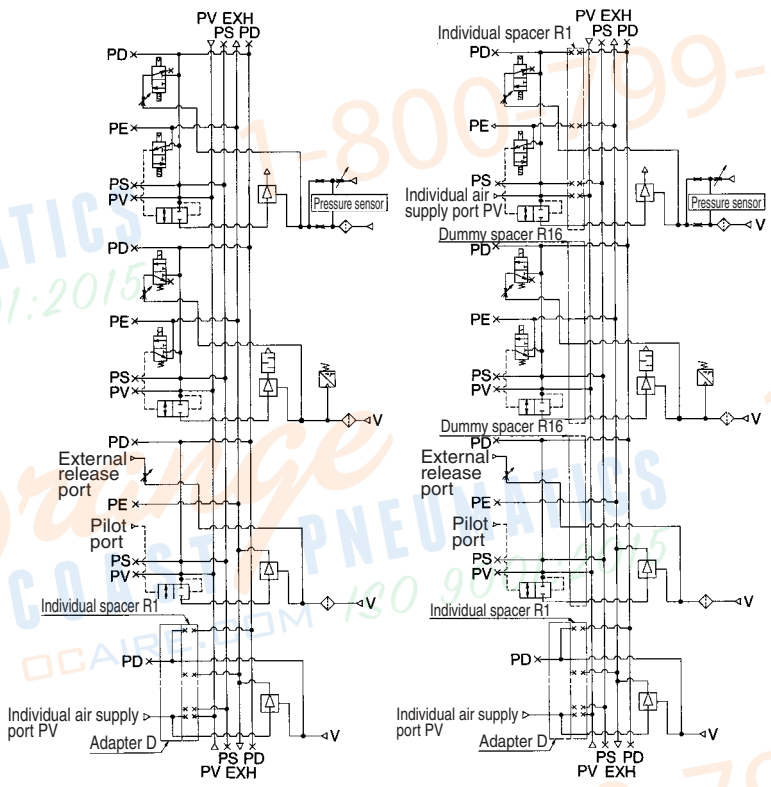

ZA
ZX
ZR
ZM
ZMA
ZQ
ZH
ZU
ZL
ZY□
ZF□
ZP□
SP
ZCUK
AMJ
AMV
AEP
HEP
Related Equipment

Series ZX

Ejector System

Manifold: Type K1

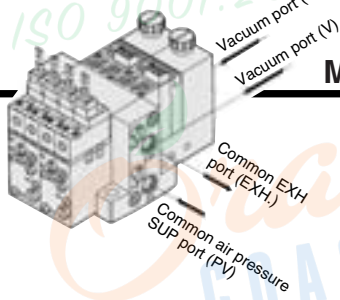

A: Release flow rate adjusting needle with lock nut

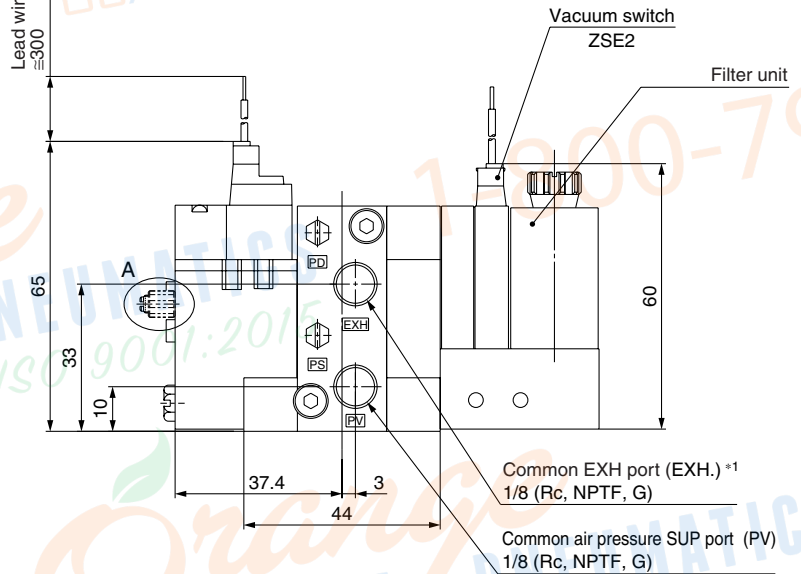
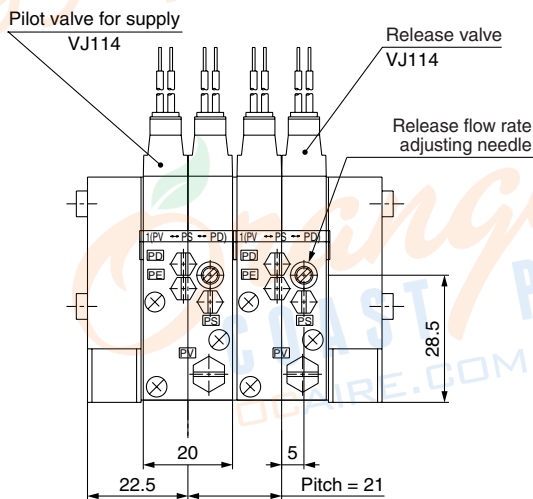
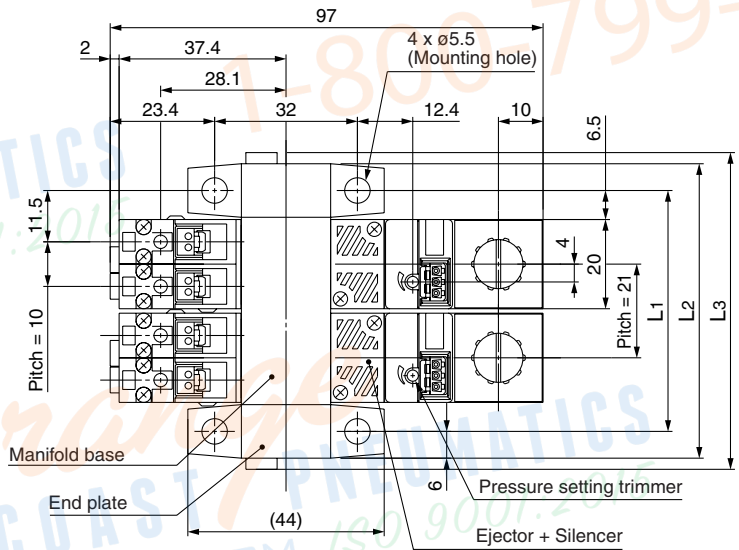
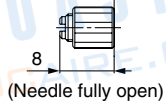

*1 The common exhaust port (EXH.) is also used as the pilot pressure exhaust (PE) port of pilot valve. Use while the port is open to the atmosphere.

Symbol	Stations							
	1	2	3	4	5	6	7	8
L1	33	54	75	96	117	138	159	180
L2	45	66	87	108	129	150	171	192
L3	50	71	92	113	134	155	176	197

(mm)

Circuit diagram

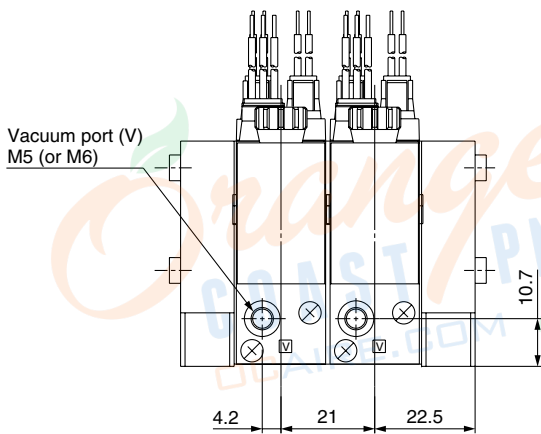
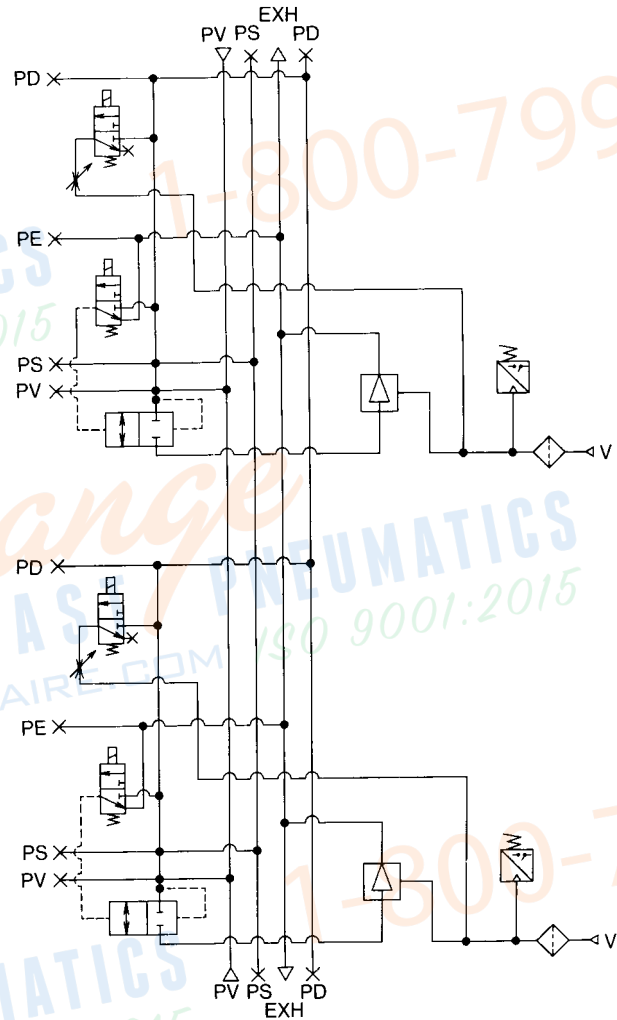

ZA
ZX
ZR
ZM
ZMA
ZQ
ZH
ZU
ZL
ZY□
ZF□
ZP□
SP
ZCUK
AMJ
AMV
AEP
HEP
Related Equipment

Series ZX

Ejector System

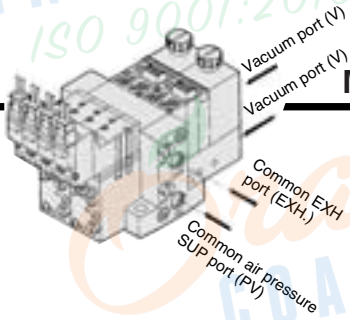

Manifold: Type K3

A: Release flow rate adjusting needle with lock nut

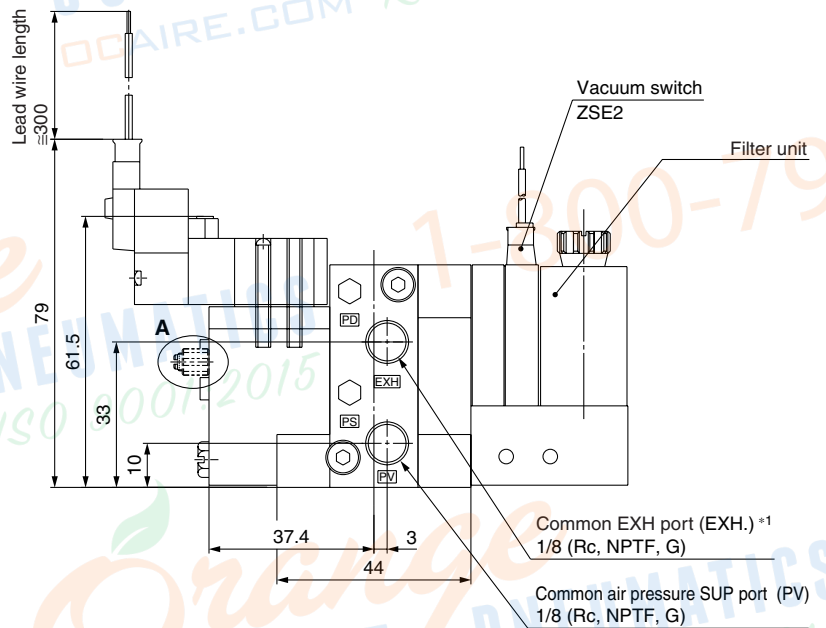
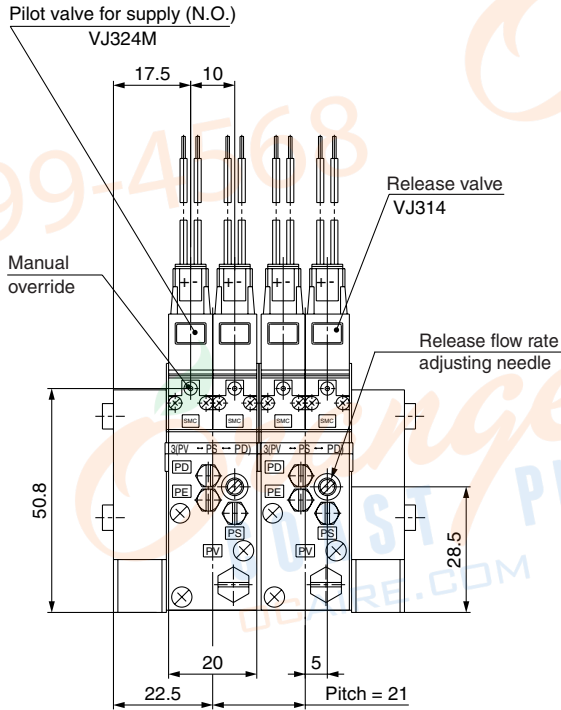
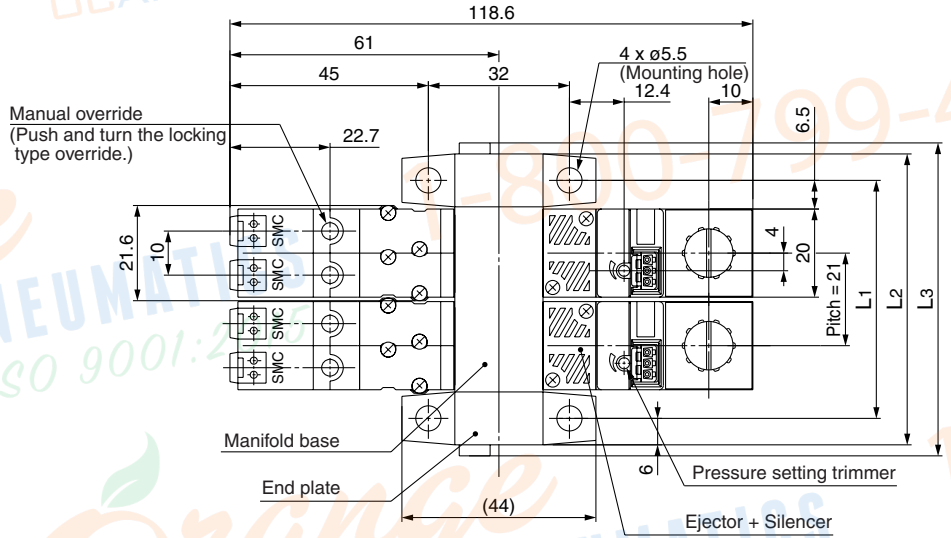
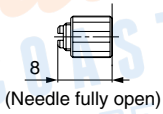

*1 The common exhaust port (EXH.) is also used as the pilot pressure exhaust (PE) port of pilot valve. Use while the port is open to the atmosphere.

Symbol	Stations							
	1	2	3	4	5	6	7	8
L1	33	54	75	96	117	138	159	180
L2	45	66	87	108	129	150	171	192
L3	50	71	92	113	134	155	176	197

(mm)

Circuit diagram

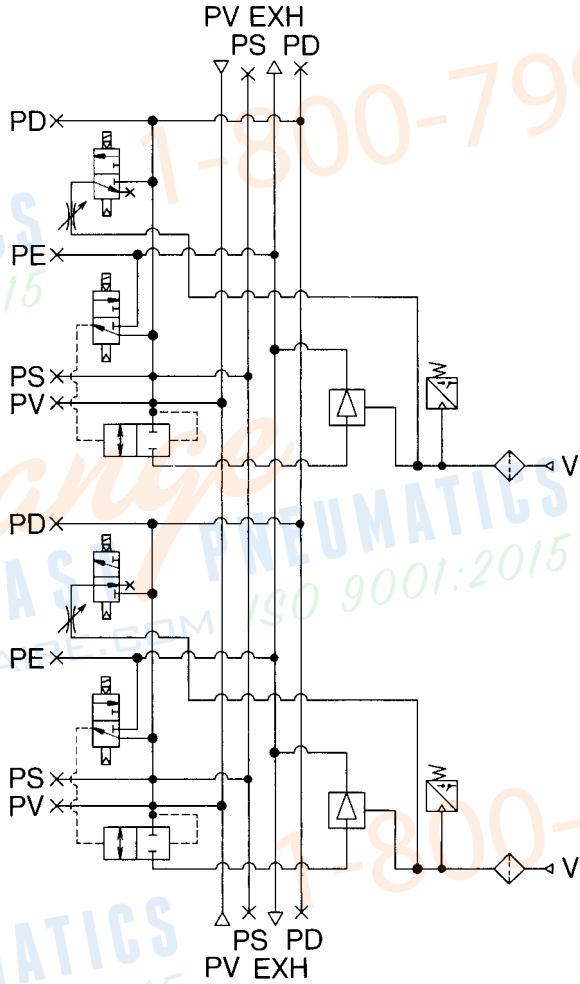
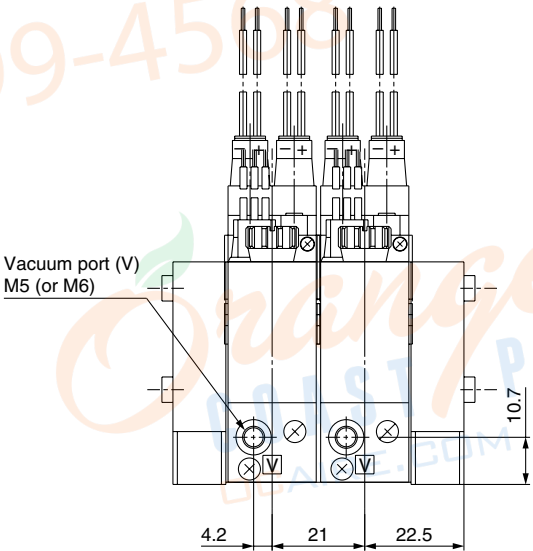

ZA
ZX
ZR
ZM
ZMA
ZQ
ZH
ZU
ZL
ZY□
ZF□
ZP□
SP
ZCUK
AMJ
AMV
AEP
HEP
Related Equipment

Vacuum Module: Vacuum Pump System Series ZX



Note) Refer to "How to Order" for CE compliant products. [Option]

How to Order

Components

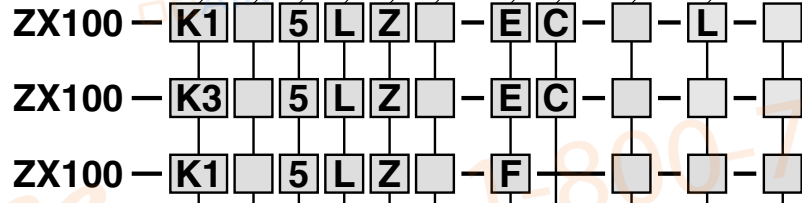
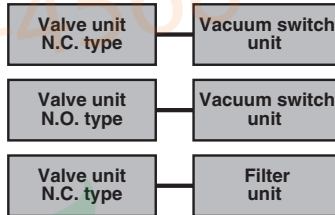

Valve unit/Combination of supply valve and release valve
Refer to "Table (1)" on page 903.

Pilot valve

Nil	DC: 1 W (With indicator light: 1.05 W) AC
Y*	DC: 0.45 W (With indicator light: 0.5 W)

* Only 24 VDC and 12 VDC are applicable to 0.45 W.

Solenoid valve rated voltage

		CE compliant
1 [#] Note)	100 VAC 50/60 Hz	—
3 [#] Note)	110 VAC 50/60 Hz	—
5	24 VDC	●
6	12 VDC	●
V	6 VDC	●
S	5 VDC	●
R	3 VDC	●
Nil	Air operated (K6, K8, J3, J4, D3, D4)	—

Note) CE compliant products are not available for "1" and "3".

* Applicable to plug connector only. (Connector assembly with rectifier is attached.)

Electrical entry

L	L plug	Lead wire length 0.3 m
LN	connector	Without lead wire (Applicable to DC only)
LO	type	Without connector
M	M plug	Lead wire length 0.3 m
MN	connector	Without lead wire (Applicable to DC only)
MO	type	Without connector
G	Grommet	Lead wire length 0.3 m (Applicable to DC only)
H	type	Lead wire length 0.6 m (Applicable to DC only)
Nil		Air operated

The filter mounted on the product is a simplified one. When used in an environment with a lot of dust, the filter is likely to be clogged quickly. The use with the series ZFA, ZFB and ZFC is recommended.



Note) In the case of "K1" (combination of supply and release valves), M type plug connector can not be used.



- Refer to "Table (2)" on page 903 for part number of lead wire with connector.
- Refer to page 916 for ordering the manifold.
- Refer to pages 926 and 927 for ordering a unit for replacement.

⚠ Caution

Surge voltage suppressor

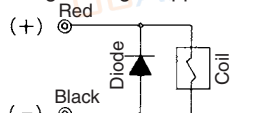

Light/Surge voltage suppressor

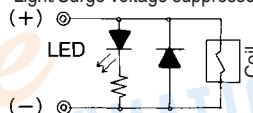

Using the DC type:
Match the polarity of the connectors according to the ⊕ and ⊖ marks on the connectors. Do not interchange the polarities to prevent the diodes or the switching elements from becoming burned. If lead wires are pre-connected, the red wire is ⊕ and the black wire is ⊖.

Using the AC type:
The AC type is not equipped with a surge voltage suppressor because the rectifier assembly prevents the generation of surge voltage.

CE compliant	
Nil	—
Q	CE compliant

Release flow rate adjusting needle

Nil	Without lock nut
L	With lock nut

PV/V port size	
Nil	M5 x 0.8
Y	M6 x 1 (Option)

Vacuum switch electrical entry

Nil	Grommet type	Lead wire length 0.6 m
L		Lead wire length 3 m
C		Lead wire length 0.6 m
CL	Connector type	Lead wire length 3 m
CN		Without connector (Without lead wire)

Refer to "Table (3)" on page 903 for part number of lead wire with connector.

Vacuum switch unit/Filter unit

		CE compliant
E	Vacuum switch (For general purpose)(ZSE2)(NPN)	●
E55	Vacuum switch (For general purpose)(ZSE2)(PNP)	With suction filter ●
PS Note)	Adsorption confirmation switch (ZSP1)	—
PB Note)	Nozzle dia. (ø0.3 to 0.7)	—
	Nozzle dia. (ø0.5 to 1.2)	—
F	Only suction filter	● Except air operated parts

Note) CE compliant products are not available for "PS" and "PB".

Vacuum digital pressure switch unit (ZSE3)

D	21	2 outputs/without analog output
	22	2 outputs/with analog output
	23	1 output (with trouble detection)/without analog output
	24	1 output (with trouble detection)/with analog output

Note) Analog output is available on grommet type only.

Manual operation

Nil	Non-locking push type
B	Locking slotted type

Light/Surge voltage suppressor

Nil	None
Z	With light/surge voltage suppressor
S*	With surge voltage suppressor

* S is not available for AC. DC voltage (with surge voltage suppressor) If the polarity is incorrect at DC (surge voltage suppressor), diode or switching element may be damaged.

Table (1) Valve Unit/Combination of Supply Valve and Release Valve



(Refer to page 904 for details specifications.)

Components		Symbol	Supply valve					Release valve					Mass (g)
Supply valve	Release valve		Solenoid valve		Air operated			Solenoid valve		Air operated	External release	None	
			N.C. (VJ114)	N.O. (VJ324)	N.C. (ZX1A)	N.O. (VJA324)	None	N.C. (VJ114)	N.C. (VJ314)	N.C. (VJA314)	ZX1A		
Solenoid (N.C.)	Solenoid (N.C.)	K1	●	—	—	—	—	●	—	—	—	—	82
Solenoid (N.O.)	Solenoid (N.C.)	K3	—	●	—	—	—	—	●	—	—	—	132
Air operated (N.C.)	External release	K6	—	—	●	—	—	—	—	—	●	—	58
Air operated (N.O.)	Air operated (N.C.)	K8	—	—	—	●	—	—	—	—	●	—	132
—		Nil	Without valve module										

Table (2) Valve Unit/Valve Plug Connector Assembly

Connector assembly part no.
(For DC)

VJ10-20-4A-6

(For 100 VAC)

VJ10-36-1A-6

(For 110 VAC)

VJ10-36-3A-6

Lead wire length

Lead wire length	Standard
Nil	0.3 m (Standard)
6	0.6 m
10	1 m
15	1.5 m
20	2 m
25	2.5 m
30	3 m

How to order

If ordering vacuum module with 600 mm or the longer lead wire, specify both vacuum module and connector assembly part numbers.

(Ordering example)

ZX100-K15LOZ-EC(-Q) 1 pc.

*VJ10-20-4A-6 2 pcs.

→ The asterisk (*) denotes the symbol for assembly.

Table (3) Vacuum Switch/Plug Connector Assembly

For ZSE2
For ZSP1

ZS-10-5A-

For ZSE3

ZS-20-5A-

Lead wire length

Lead wire length	Standard
Nil	0.6 m
30	3 m
50	5 m

Note) If ordering switch with 5 m lead wire, specify both switch and lead wire connector part numbers.

(Ordering example)

ZX100-K150Z-ECN(-Q) 1 pc.

*VJ10-20-4A-6 2 pcs.

*ZS-10-5A-50 1 pc.

→ The asterisk (*) denotes the symbol for assembly.

Ejector System/Recommended Model (The models below are for express delivery.)

Model	Combination		Solenoid valve rated voltage	Lead wire electrical entry	Light/Surge voltage suppressor	Vacuum switch unit /Filter unit	Vacuum switch electrical entry
	Supply valve (Pilot valve)	Release valve (Direct operated)					
ZX100-K15LZ-F	N.C. (VJ114)	N.C. (VJ114)	24 VDC	Plug connector type	With light/surge voltage suppressor	Suction filter (ZX1-F)	Connector type
ZX100-K15LZ-EC	N.C. (VJ114)	N.C. (VJ114)				Vacuum switch (ZSE2)	
ZX100-K35MZ-EC	N.O. (VJ324M)	N.C. (VJ314)					

*The above models are for express delivery.

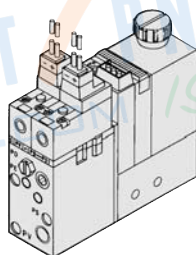

ZX100-K15LZ-E

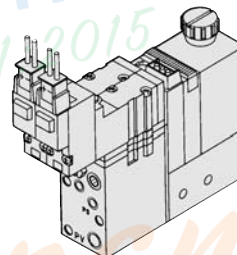

ZX100-K35MZ-E

- ZA**
- ZX**
- ZR**
- ZM**
- ZMA**
- ZQ**
- ZH**
- ZU**
- ZL**
- ZY** □
- ZF** □
- ZP** □
- SP**
- ZCUK**
- AMJ**
- AMV**
- AEP**
- HEP**

Related Equipment

Vacuum Pump System/Combination of Supply Valve and Release Valve

Combination Symbol: **K1**

Application: This combination is used for effecting control in accordance with electric signals.

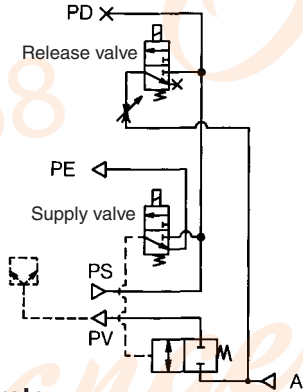

How to Operate

Condition	Valve	Supply valve	Release valve
		Solenoid valve	Solenoid valve
1. Work adsorption		ON	OFF
2. Vacuum release		OFF	ON
3. Operation stop		OFF	OFF

Combination Symbol: **K6**

Application: This combination is used for effecting control in accordance with air signals.

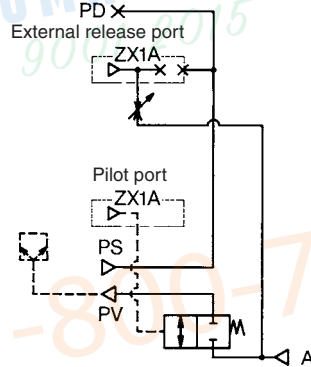

How to Operate

Condition	Valve	Supply valve	Release valve
		Solenoid valve	Solenoid valve
1. Work adsorption		ON	OFF
2. Vacuum release		OFF	ON
3. Operation stop		OFF	OFF

Combination Symbol: **K3**

Application: This combination is used for effecting control in accordance with electric signals. Because the supply valve is N.O., the pressure that is supplied to the ejector is not interrupted during a power outage; as a result, the state of suction can be maintained. This combination is used for preventing the workpieces from dropping during power outages.

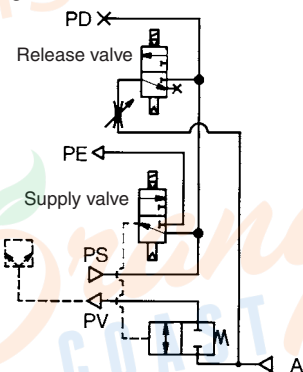

How to Operate

Condition	Valve	Supply valve	Release valve
		Solenoid valve	Solenoid valve
1. Work adsorption		OFF	OFF
2. Vacuum release		ON	ON
3. Operation stop		ON	OFF

Combination Symbol: **K8**

Application: This combination is used for effecting control in accordance with air signals. Because the supply valve is N.O., the pressure that is supplied to the ejector is not interrupted during a power outage; as a result, the state of suction can be maintained. This type is used for preventing the workpieces from dropping during power outages.

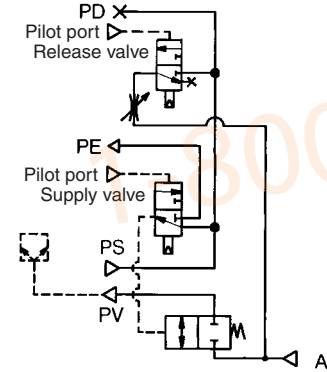

How to Operate

Condition	Valve	Supply valve	Release valve
		Air operated valve	Air operated valve
1. Work adsorption		OFF	OFF
2. Vacuum release		ON	ON
3. Operation stop		ON	OFF

Vacuum Pump System/Construction

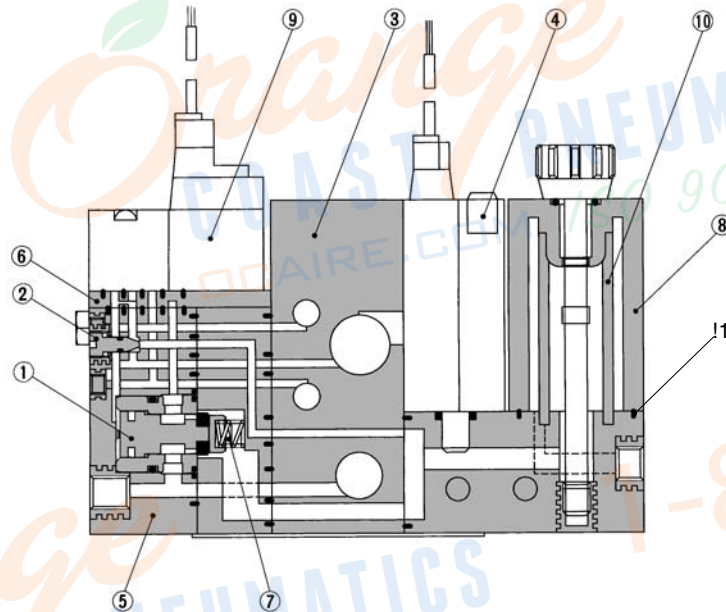

Component Parts

No.	Description	Material	Note
1	Poppet valve assembly	—	ZX1-PV-0
2	Release flow rate adjusting needle	Stainless steel	
3	Manifold base	Aluminum	
4	Vacuum switch	—	ZSE2, ZSP1, ZSE3
5	Valve unit	—	ZX1-VB□□□□□□-D-□
6	Interface plate	—	(PV)/(PS↔PD)
7	Return spring	Stainless steel	
8 ^{Note)}	Filter case	Polycarbonate	

Replacement Parts

No.	Description	Material	Part no.
9	Pilot valve	—	Refer to "Table (2)", "(3)".
10	Filter element	PVF	ZX1-FE
11	Gasket	—	ZX1-FG

- Note) Caution when handling filter case
- The case is made of polycarbonate. Therefore, do not use it with or expose it to the following chemicals: paint thinner, carbon tetrachloride, chloroform, acetic ester, aniline, cyclohexane, trichloroethylene, sulfuric acid, lactic acid, watersoluble cutting oil (alkalinic), etc.
 - Do not expose it to direct sunlight.

Table (1) How to Order Pilot Valves

No.	Component equipment		Model	Combination of supply and release valve
	Supply valve	Release valve		
1	Solenoid valve N.C. (VJ114)	Solenoid valve N.C. (VJ114)	ZX1-VJ114-□□□□	K1, J1
2	Solenoid valve N.O. (VJ324)	Solenoid valve N.C. (VJ314)	ZX1-VJ3 ¹ / ₂ 4-□□□□	K3, J2
3	Air operated N.O. (VJA324)	Air operated N.C. (VJA314)	ZX1-VJA3 ¹ / ₂ 4	K6
4	Solenoid valve Air operated	Air operated Solenoid valve	No. 2 and 3 models only are applicable. Indicate each part number.	

Table (2) How to Order Solenoid Valves

ZX1-VJ114 □ - **5** **L** **Z** □

ZX1-VJ3¹/₂4 □ **4** □ □ - **5** **L** **Z** □

Type of actuation

1	N.C. (Normally closed)
2	N.O. (Normally open)

Manual override

NII	Non-locking push type
B	Locking slotted type

Body option

NII	Pilot valve Individual exhaust
M	Common exhaust for main and pilot valves

Rated voltage

1*	100 VAC
3*	110 VAC
5	24 VDC
6	12 VDC
V	6 VDC
S	5 VDC
R	3 VDC

Electrical entry

L	Connector (0.3 m)
LN	Connector (W/o lead wire)
LO	Without connector
M	Connector (0.3 m)
MN	Connector (W/o lead wire)
MO	Without connector
G	Grommet (0.3 m)
H	Grommet (0.6 m)

Light/Surge voltage suppressor

NII	Without light/surge voltage suppressor
S	With surge voltage suppressor
Z	With light/surge voltage suppressor

Pilot valve

NII	DC: 1 W (With indicator light: 1.05 W)
AC	AC
Y*	DC: 0.45 W (With indicator light: 0.5 W)

* 24 VDC and 12 VDC are applicable to 0.45 W.

Note) In the case of N.C. type, indicate no symbol. (Individual exhaust for Pilot valve)

Note) Compatible with ZX1-VJ324M-□ and ZX1-VJ314-□ only.

Note) In the case of ZX1-VJ114, M, MN and MO cannot be used.

*Applicable to plug connector

*Screw length> VJ100-M1.7 x 15
VJ300-M1.7 x 22

Table (3) How to Order Air Operated Valves

ZX1A-M3

Port size

M3	M3 x 0.5	Pilot port/External release port
M5	M5 x 0.8	

Caution

Turning the vacuum release flow volume adjusting needle clockwise reduces the vacuum release flow volume; the needle valve is fully closed when the needle stops turning. Turning the needle 2 full turns counterclockwise from the fully closed position renders the needle valve fully open. The needle will fall out if it is turned more than 4 full turns. In order to prevent the needle from loosening and falling out, a special product is also available.

- ZA
- ZX**
- ZR
- ZM
- ZMA
- ZQ
- ZH
- ZU
- ZL
- ZY□
- ZF□
- ZP□
- SP
- ZCUK
- AMJ
- AMV
- AEP
- HEP
- Related Equipment

Valve Unit: ZX1-VB

Refer to page 872 for details.

Model/Specifications

Unit no.	ZX1-VB□□□□□□□					
Components	Supply valve			Release valve		
	Pilot type			Direct operated type		
Operation	Solenoid valve		Air operated		Solenoid valve	
	N.C. (VJ114)	N.O. (VJ324)	N.C. (ZX1A)	N.O. (VJA324)	N.C. (VJ114)	N.C. (VJ314)
Cv factor	0.17			0.008	0.08	—
Operating pressure range	0.3 to 0.6 MPa					
Max. operating frequency	5 Hz					
Operating temperature range	5 to 50°C					
Interface plate symbol	(PV)•(PS↔PD)					
Standard accessory	Bracket B (ZX1-0BB)					

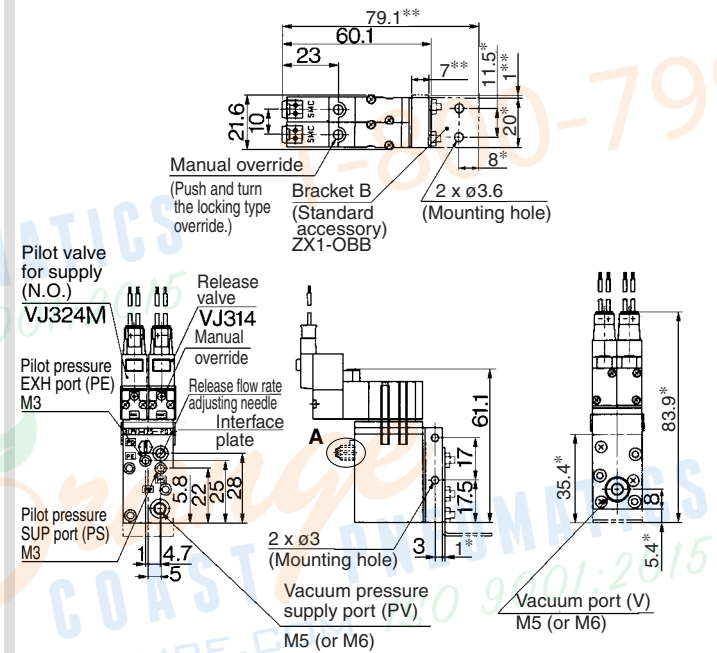
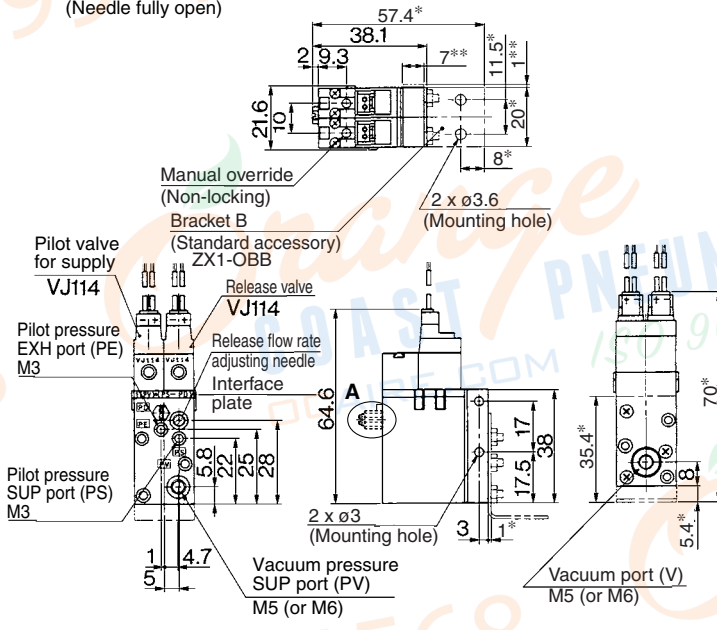
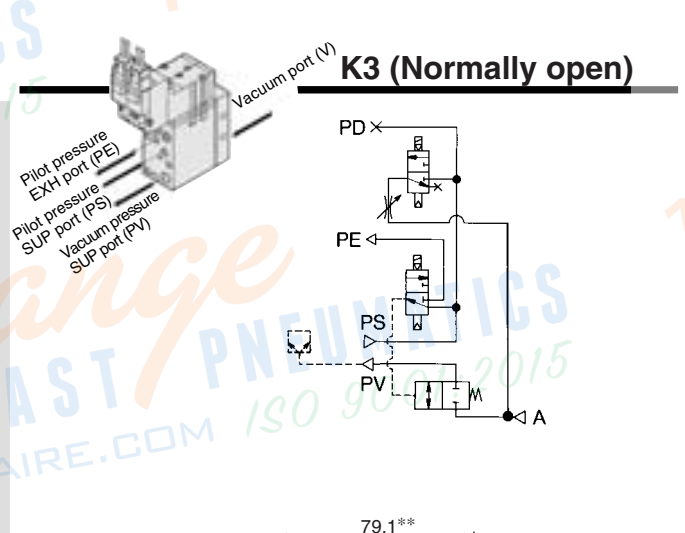
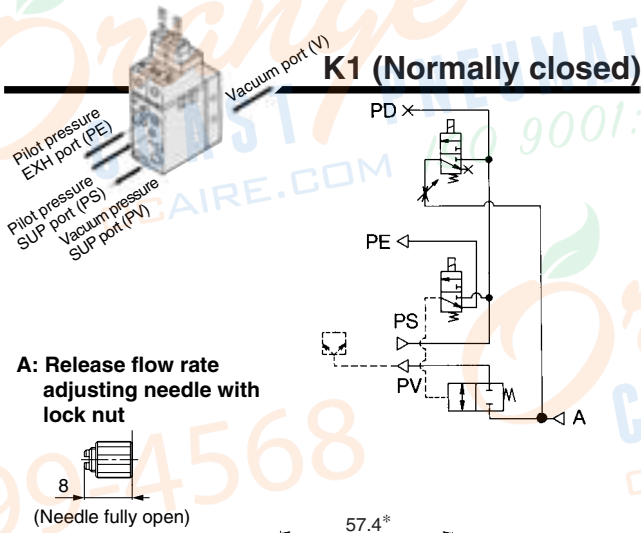

Note) Dimensions *: For mounting bracket B **: For mounting spacer

Suction Filter Unit: ZX1-F

Refer to page 874 for details.



Specifications

Unit no.	ZX1-F
Operating pressure range	Vacuum to 0.5 MPa
Operating temperature range	5 to 50°C
Filtration efficiency	30 μm
Filter media	PVF
Mass	35 g
Standard accessory	Bracket A (ZX1-OBA)



Note) If not operated within the specified range of pressure and temperature, trouble may be caused.

Vacuum Pressure Switch Unit/ZSE2, ZSE3, ZSP1

Refer to pages 875 to 880 for details.

Vacuum Pressure Switch

High speed response/10 ms
Uses a carrier diffusion semiconductor pressure sensor



Adsorption Confirmation Switch

Suitable for small size adsorption nozzle/ø0.3 to ø1.2
With suction filter
Improved wiring: connector type
Uses a carrier diffusion semiconductor pressure sensor



Vacuum Pressure Switch Specifications



Refer to Best Pneumatics Vol.6 for details.

Unit no.	ZSE2-0X	ZSE3-0X
Fluid	Air	
Set pressure range	0 to -101 kPa	
Hysteresis	3% Full span or less	
Repeatability	±1% Full span or less	
Temperature characteristics	±3% Full span or less	
Voltage	12 to 24 VDC (Ripple ±10% or less)	
Port size	M5 x 0.8, M6 x 1 (Option)	



Note) If not operated within the specified range of pressure and temperature, trouble may be caused.

Adsorption Confirmation Switch Specifications

Unit no.	ZSP1-S	ZSP1-B
Fluid	Air	
Operating pressure range	-20 to -101 kPa	
Applicable adsorption nozzle dia.	0.3 to 0.7 mm	0.5 to 1.2 mm
Hysteresis	0.5 kPa	
Internal orifice	0.5 mm	0.8 mm

• Filter case

⚠ Caution

- The case is made of polycarbonate. Therefore, do not use it with or expose it to the following chemicals: paint thinner, carbon tetrachloride, chloroform, acetic ester, aniline, cyclohexane, trichloroethylene, sulfuric acid, lactic acid, water-soluble cutting oil (alkalinic), etc.
- Do not expose it to direct sunlight.

• Other caution

⚠ Caution

It might not be possible to successfully pick a workpiece if a picking nozzle or a picking pad that is out of the applicable range is used.

ZA

ZX

ZR

ZM

ZMA

ZQ

ZH

ZU

ZL

ZY□

ZF□

ZP□

SP

ZCUK

AMJ

AMV

AEP

HEP

Related Equipment

Vacuum switch (ZSE3)
ZX100-K1□□□□-D□□

A: Release flow rate adjusting needle with lock nut

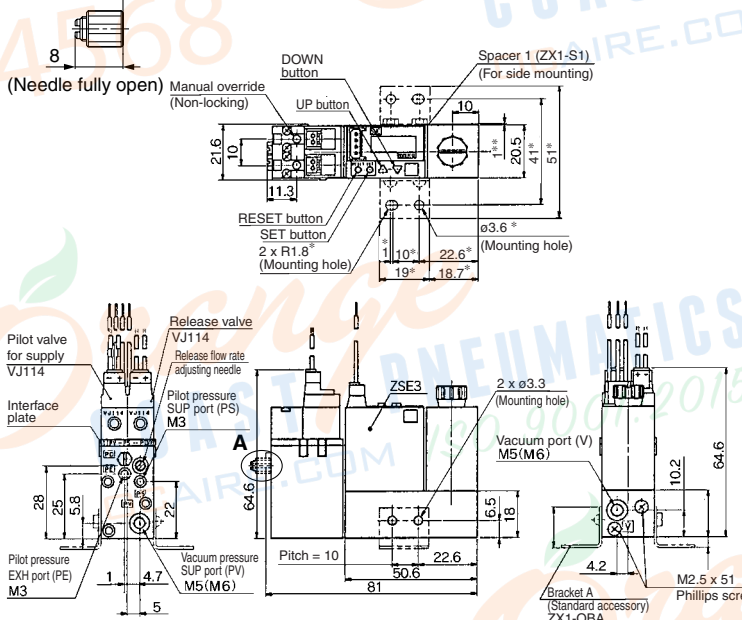

Adsorption confirmation switch (ZSP1)
ZX100-K1□□□□-P□□

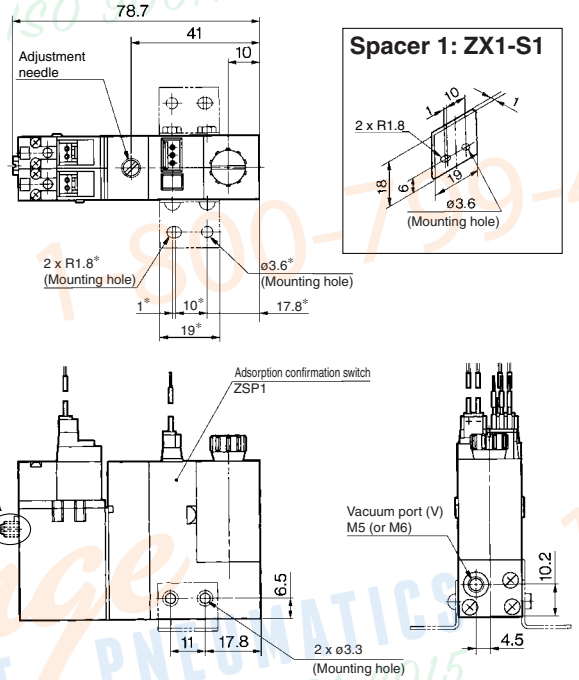

Filter unit (F)
ZX100-K1□□□□-F

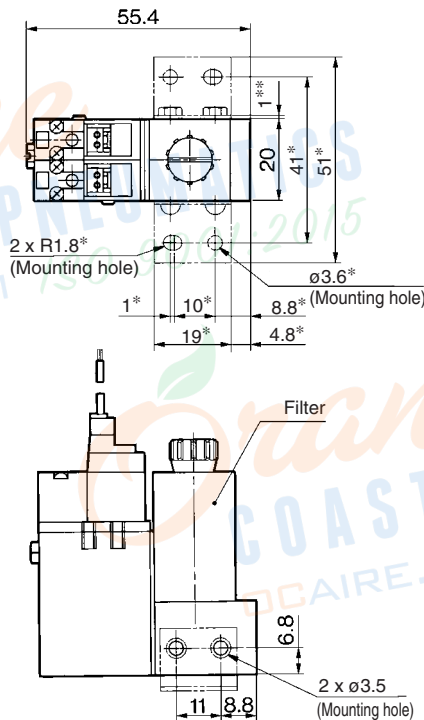

ZA
ZX
ZR
ZM
ZMA
ZQ
ZH
ZU
ZL
ZY□
ZF□
ZP□
SP
ZCUK
AMJ
AMV
AEP
HEP
Related Equipment

Series ZX

Valve Unit: Type K3

Configuration and combination

Valve unit (K3) +

- Vacuum switch (ZSE2)
- Vacuum switch (ZSE3)
- Adsorption confirmation switch (ZSP1)
- Filter unit (F)

Model
ZX100

K3□□□□

- E □
- P □
- F □
- D □□□

Vacuum switch (ZSE2) ZX100-K3□□□□-E□

A: Release flow rate adjusting needle with lock nut

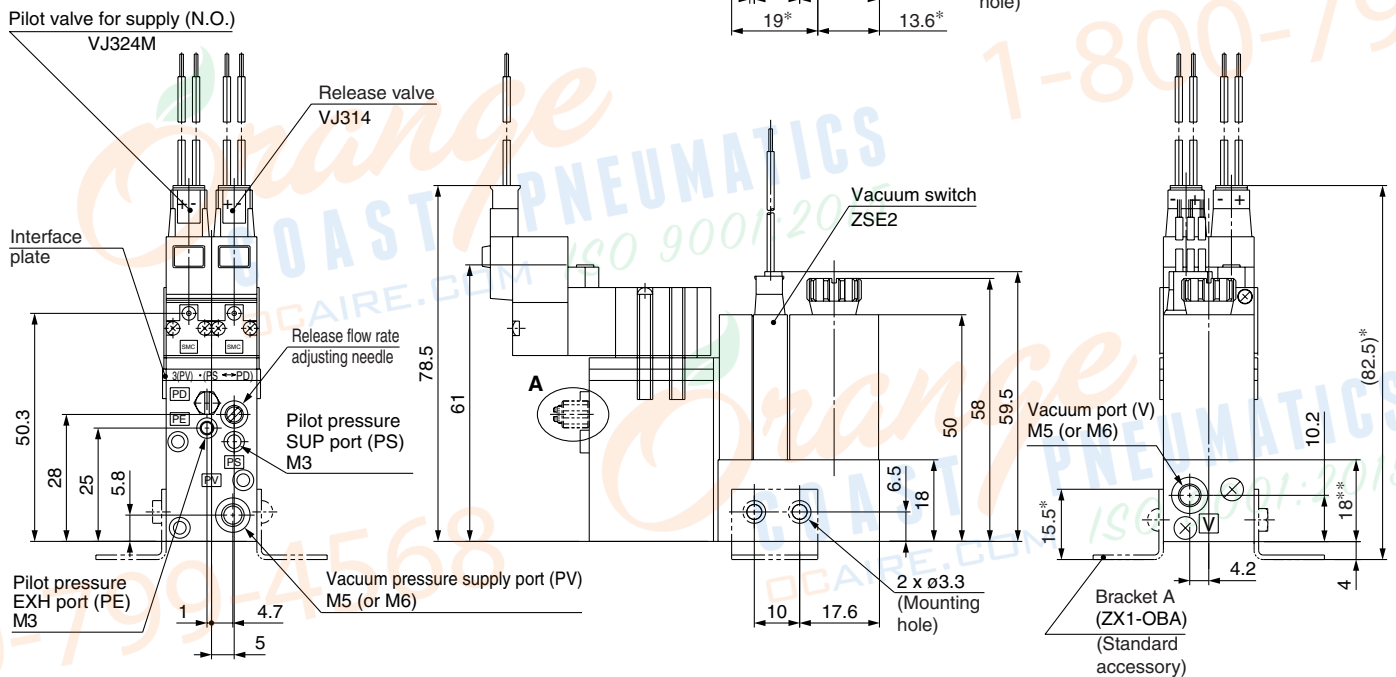
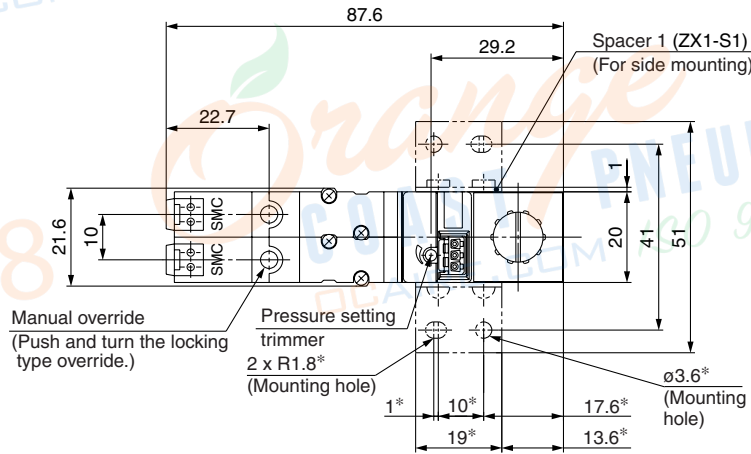
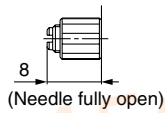

Note) Dimensions *: For mounting bracket A **: For mounting spacer 1.

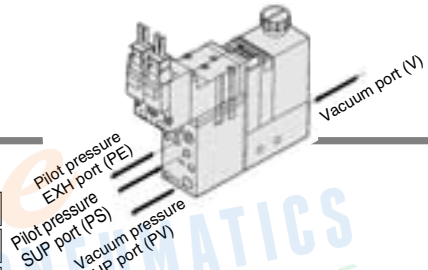

Circuit diagram

(Circuits other than those with vacuum switch are shown as below.)

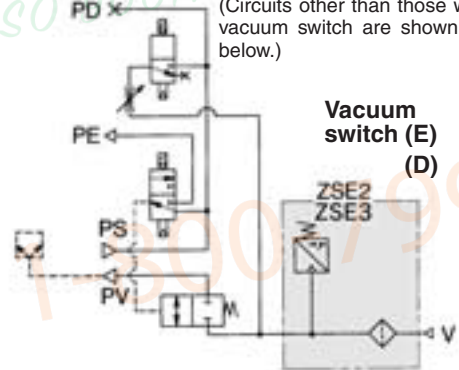

Vacuum switch (E) (D)

Adsorption confirmation switch (P)

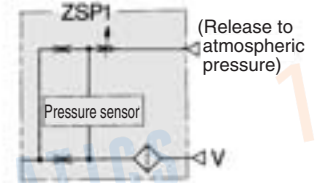

Filter unit (F)

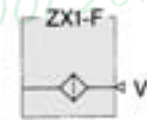

**Adsorption confirmation
switch (ZSP1)**
ZX100-K3□□□□-P□□

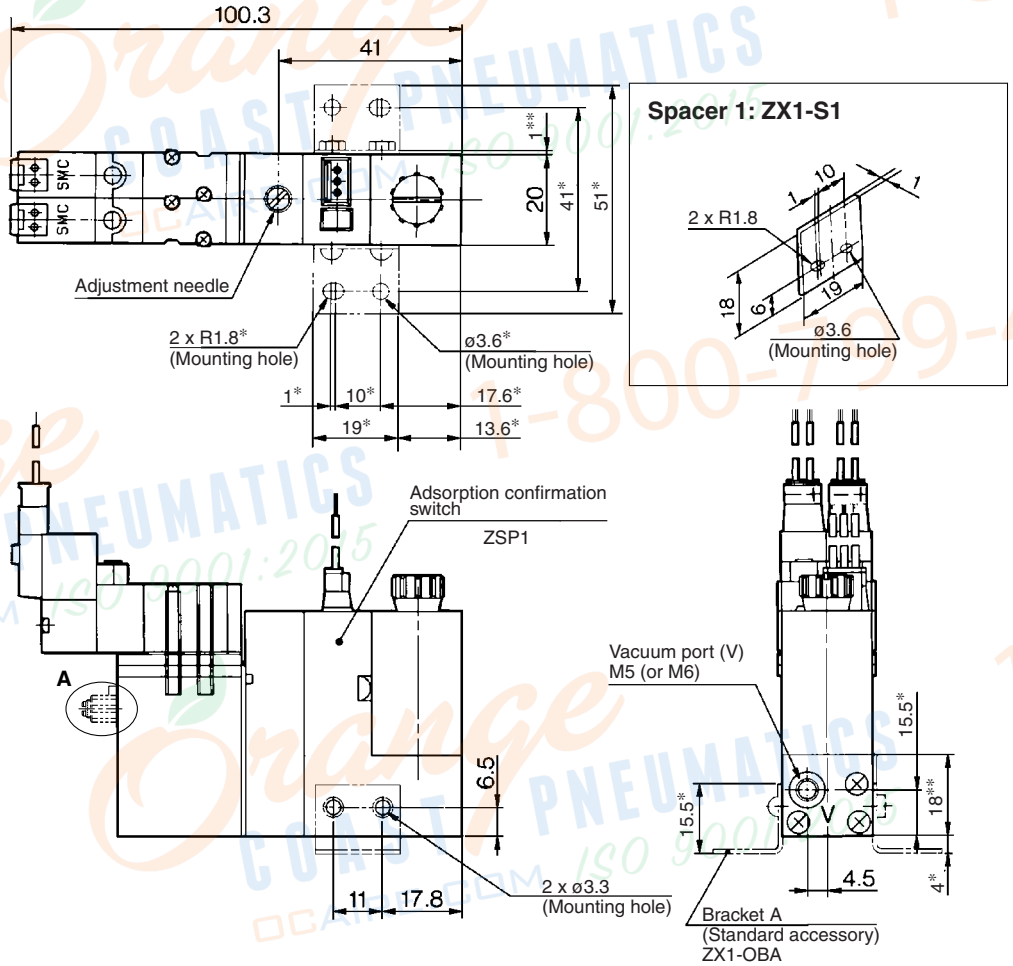

- ZA
- ZX**
- ZR
- ZM
- ZMA
- ZQ
- ZH
- ZU
- ZL
- ZY□
- ZF□
- ZP□
- SP
- ZCUK

Filter unit (F)
ZX100-K3□□□□-F

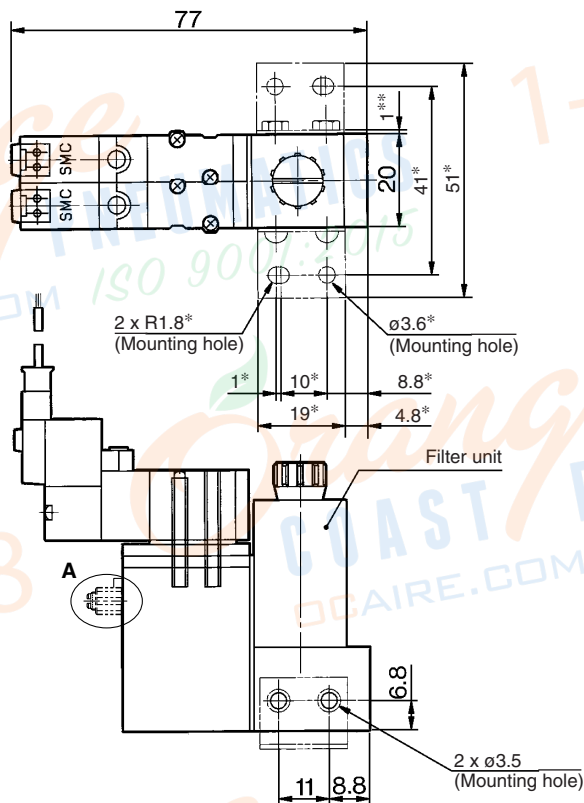

- AMJ
- AMV
- AEP
- HEP
- Related
Equipment

Series ZX

Valve Unit: Type K6

Configuration and combination

Valve unit (K6) +

- Vacuum switch (ZSE2)
- Vacuum switch (ZSE3)
- Adsorption confirmation switch (ZSP1)
- Filter unit (F)

Model ZX100 — K6 —

- E
- P
- F
- D

Vacuum switch (ZSE2)
ZX100-K6-E

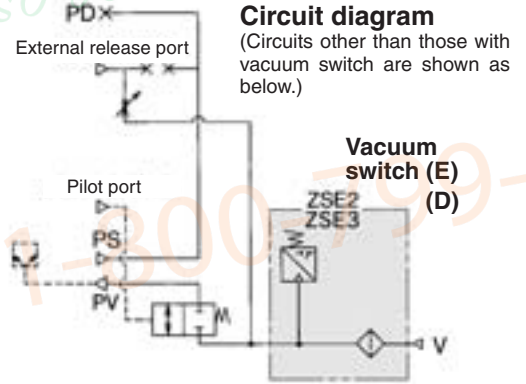
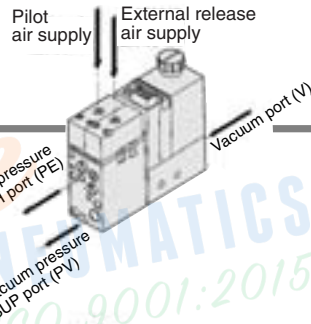

Circuit diagram

(Circuits other than those with vacuum switch are shown as below.)

Adsorption confirmation switch (P)

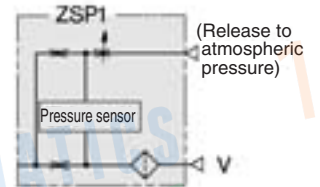

Filter unit (F)

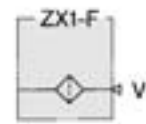

A: Release flow rate adjusting needle with lock nut

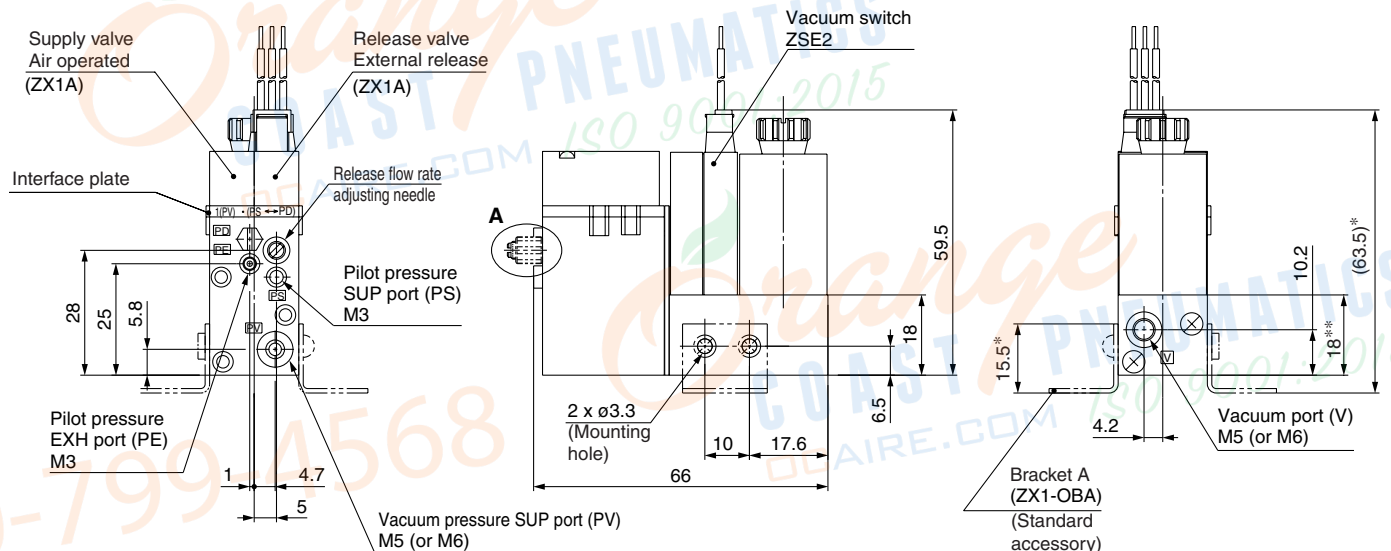
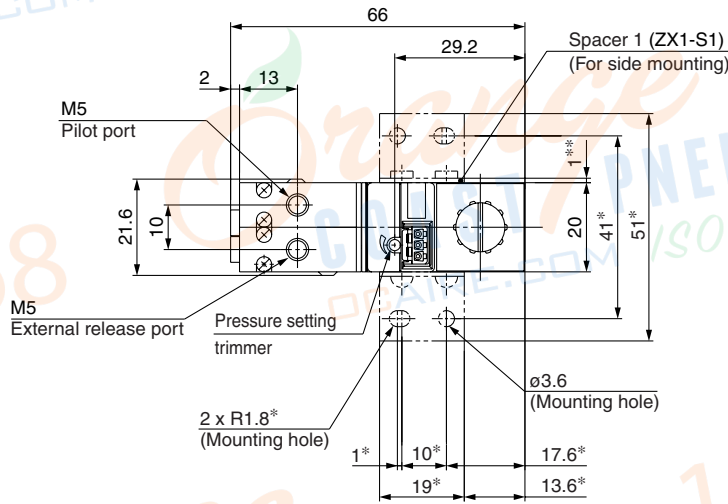
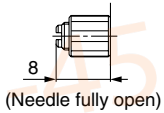

Note) Dimensions *: For mounting bracket A **: For mounting spacer 1.

**Adsorption confirmation
switch (ZSP1)**
ZX100-K6-P□□

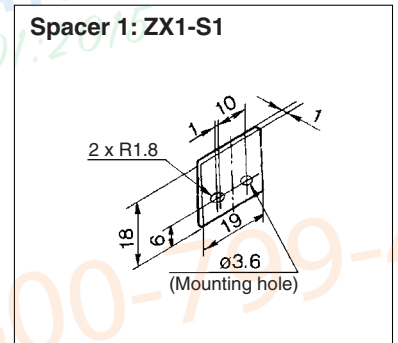
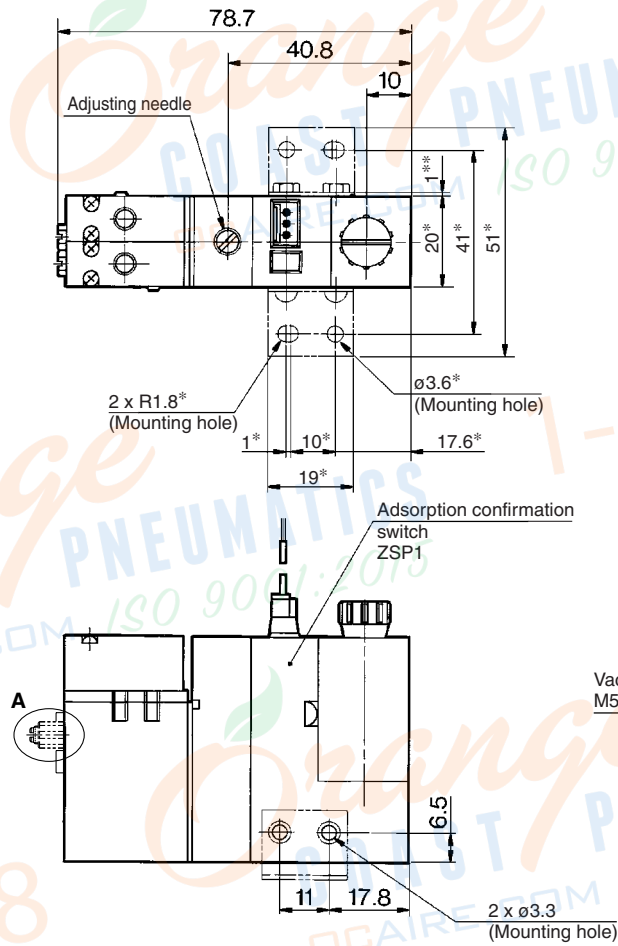

**A: Release flow rate
adjusting needle
with lock nut**

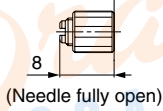

Filter unit (F)
ZX100-K6-F

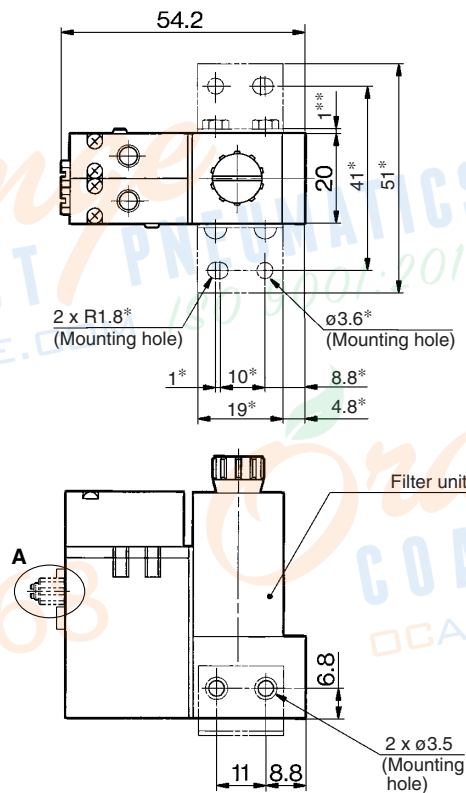

ZA
ZX
ZR
ZM
ZMA
ZQ
ZH
ZU
ZL
ZY□
ZF□
ZP□
SP
ZCUK
AMJ
AMV
AEP
HEP
Related Equipment

Series ZX

Valve Unit: Type K8

Configuration and combination

Valve unit (K8) +

- Vacuum switch (ZSE2)
- Vacuum switch (ZSE3)
- Adsorption confirmation switch (ZSP1)
- Filter unit (F)

Model ZX100 — K8 —

- E
- P
- F
- D

Vacuum switch (ZSE2)
ZX100-K8-E

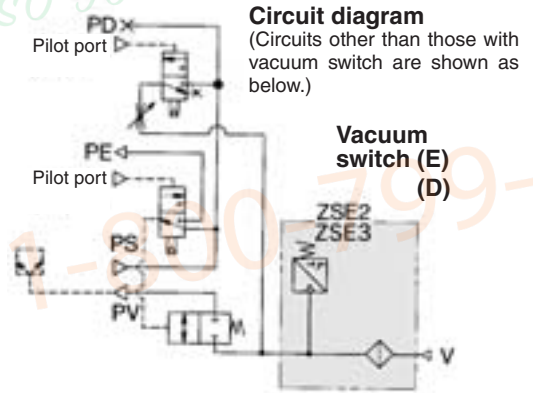
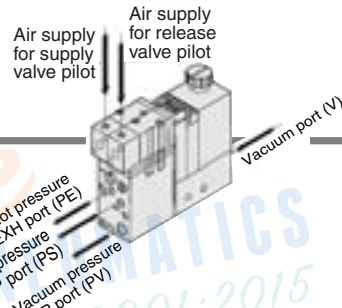

Circuit diagram
(Circuits other than those with vacuum switch are shown as below.)

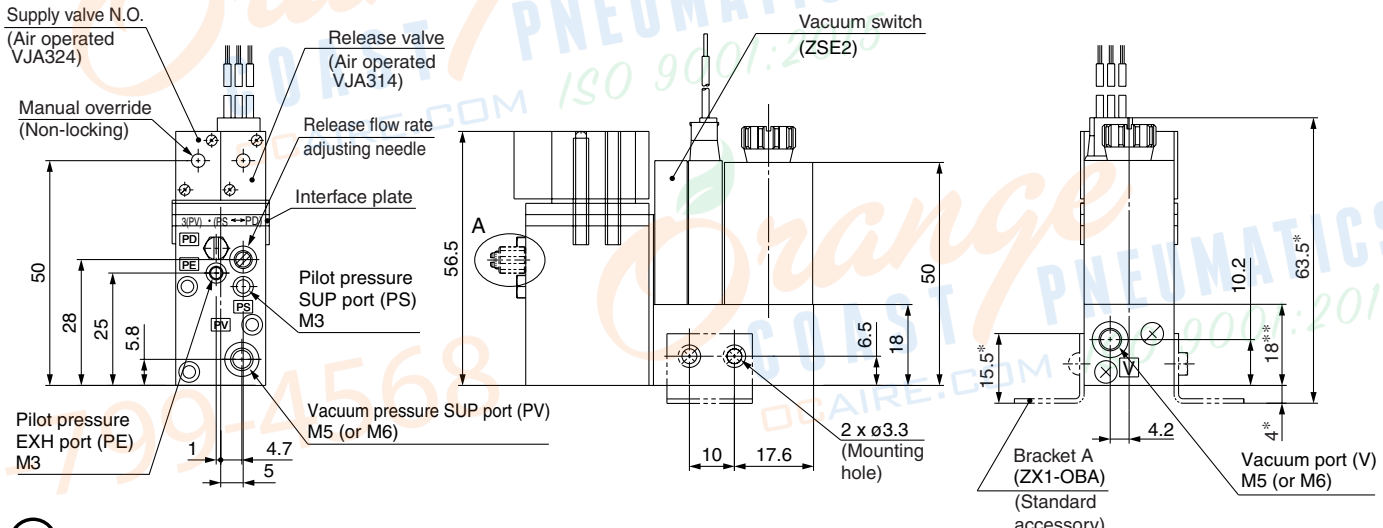
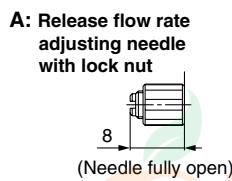
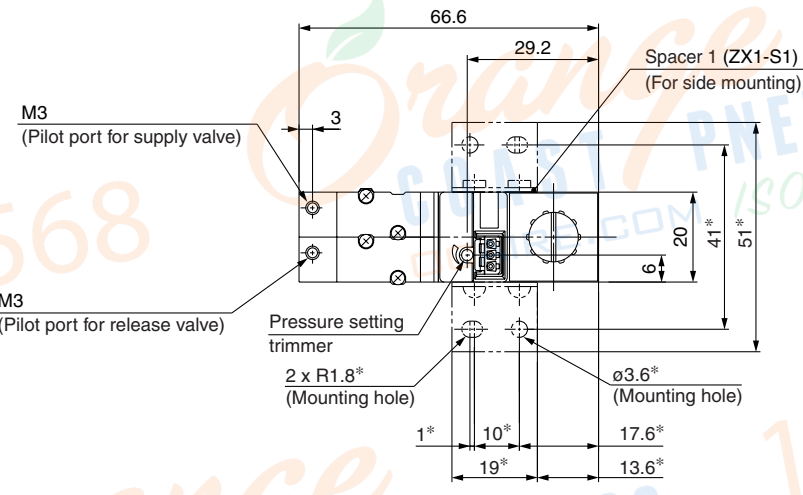
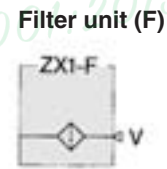
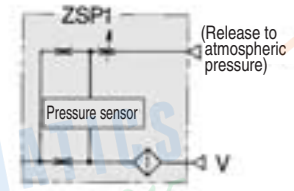
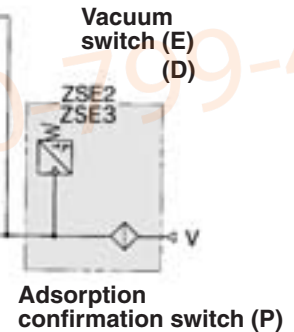

Note) Dimensions *: For mounting bracket A **: For mounting spacer 1.

**Adsorption confirmation
switch (ZSP1)**
ZX100-K8-P□□

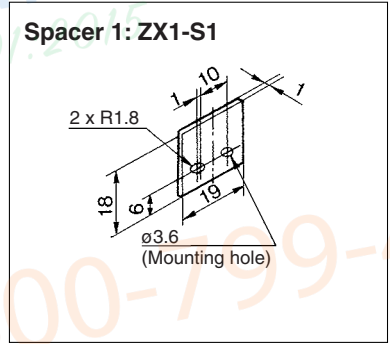
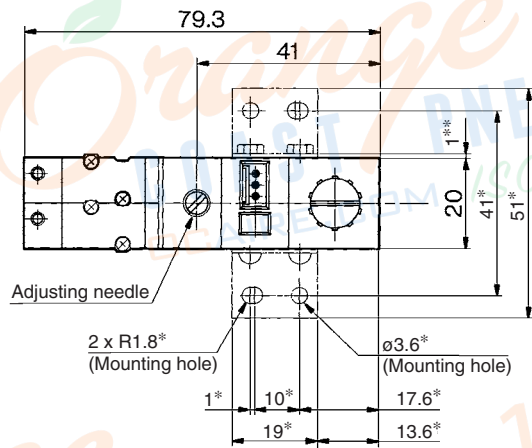

**A: Release flow rate
adjusting needle
with lock nut**

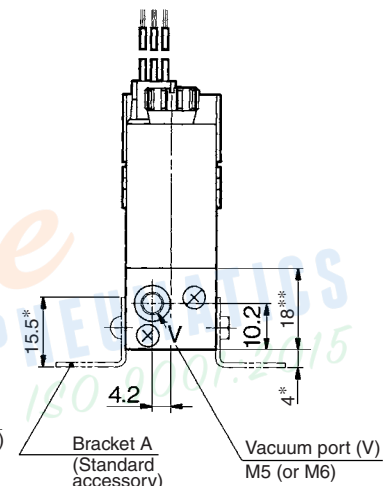
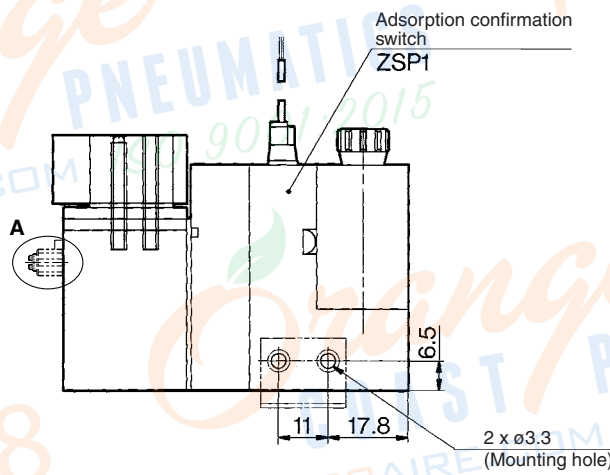
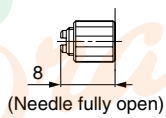

Filter unit (F)
ZX100-K8-F

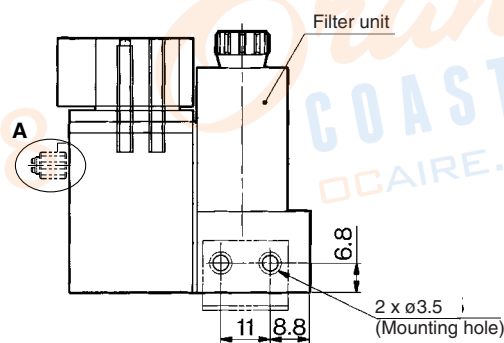
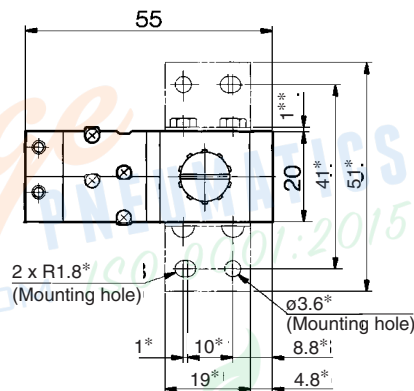

ZA
ZX
ZR
ZM
ZMA
ZQ
ZH
ZU
ZL
ZY□
ZF□
ZP□
SP
ZCUK
AMJ
AMV
AEP
HEP

Related
Equipment

Vacuum Pump System/Manifold Specifications

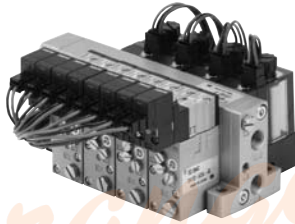
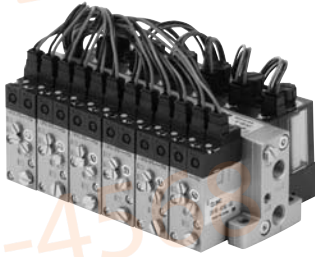

Specifications

Max. number of units		Max. 8 units
Port size	Supply port [PV]	1/8 (Rc, NPTF, G)
	Exhaust port [EXH]	1/8 (Rc, NPTF, G)
Mass		1 station: 73 g (50 g per additional station)

Note 1) PD port: Blank

Note 2) Vacuum from both sides of PV port for 6 or more stations of ZX100 external vacuum pump manifold.

Air Supply

Supply port location	Manifold Port		Left side		Right side	
	PV	PS	PV	PS	PV	PS
L (Left)	○	○	●	●	○	○
R (Right)	●	●	○	○	○	○
B (Both sides)	○	○	○	○	○	○

○: Vacuum supply from PV port ○: Air supply from PS port

●: Plugged

⦿ Note) All ports for each valve unit are provided with plugs.

How to Order Manifold

<Manifold base>

ZZX1 06 - [] R

Stations

01	1
02	2
⋮	⋮
08	8

Supply port location

Symbol	Supply port location *1	Air Supply	
		Vacuum supply	Air supply
R	Right side	PV port on the right side	PS port on the right side
L	Left side	PV port on the left side	PS port on the left side
B	Both sides	PV port on both sides	PS port on both sides

- * 1 Viewed from the front side of valve unit, confirm the port location on the right and/or left side.
- * 2 EXH ports are released to atmospheric pressure in both sides. Plugs are always attached to PD ports and all ports of the valve unit.

(Ordering example)

ZZX106-R1 pc. (Manifold base)

*ZX100-K15LZ-EC(-Q)

.....5 pcs. (Vacuum single unit)

*ZX1-BM1

.....1 pc. (Blank plate)

Thread of supply and exhaust valve

Nil	Rc
F	G (Note)
T	NPTF

Note) G thread

The thread ridge shape is compatible with the G thread standard (JIS B0202), but other shapes are not conforming to ISO16030 and ISO1179.

⚠ Caution when ordering manifold

The asterisk denotes the symbol for assembly. Prefix it to the ejector part numbers to be mounted. When it is not added, the manifold base and ejector are shipped separately.

<Individual spacer>

Specify the individual spacer when separating the supply and exhaust ports of the manifold ejector.

ZX1 - R1 - 1

Individual spacer

R1
⋮
R16

*Refer to the individual spacer.

(Ordering example)

If installed on station 1 and station 3:

ZZX106-R1 pc.

*ZX100-K15LZ-EC(-Q)

.....6 pcs.

*ZX1-R1-1

*ZX1-R1-3

*ZX1-R16 (Dummy spacer)

.....4 pcs.

Arrangement

(First station from the right end of the valve side is station 1.)

Nil	All stations
1	Station 1 only
⋮	⋮
8	Station 8 only

*When spacers are mounted alternately, specify them together.

*When retrofitting, 3 pcs. of M2.5 x 32 (for ZX) are necessary. A dummy spacer (ZX1-R16) must be mounted on the stations on which individual spacers are not mounted.

About individual spacers

- Manifold supply or valve unit supply can be selectable for each port. In the table below, ports with the symbol † mean that they are manifold supply, while others are individual supply from the valve unit.
- Symbols in the table below are printed on the surface of individual spacers.

Part no.	Symbol	Part no.	Symbol
ZX1-R1	R1	ZX1-R 9	R 9 † PV
R2	R2 † PE	R10	R10 † PV † PE
R3	R3 † PD	R11	R11 † PV † PD
R4	R4 † PD † PE	R12	R12 † PV † PD † PE
R5	R5 † PS	R13	R13 † PV † PS
R6	R6 † PS † PE	R14	R14 † PV † PS † PE
R7	R7 † PS † PD	R15	R15 † PV † PS † PD
R8	R8 † PS † PD † PE	R16	R16 † PV † PS † PD † PE

Manifold/System Circuit Example

When not using individual spacer

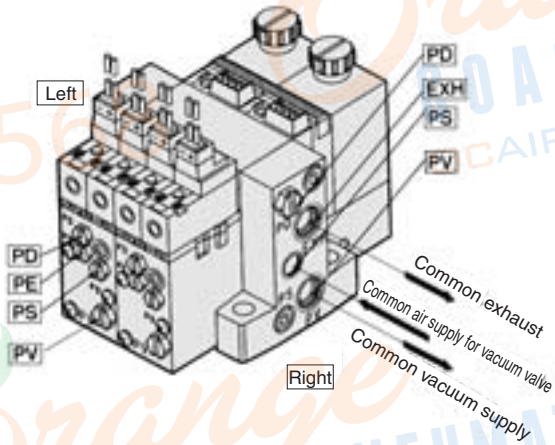

PV: Vacuum pressure SUP port
PS: Pilot pressure SUP port
PD: Release pressure SUP port
PE: Pilot pressure EXH port
EXH: Common EXH port

When using individual spacer
(When using ZX1-R1)

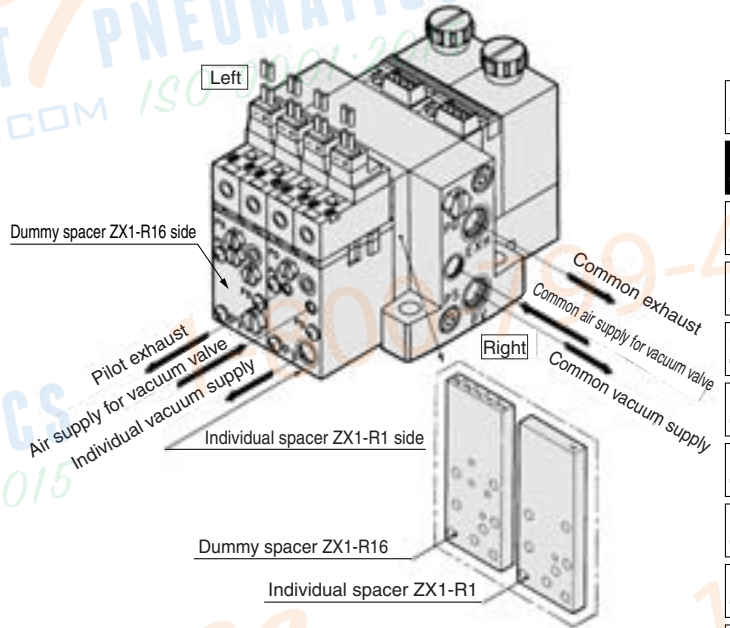

<System circuit example>

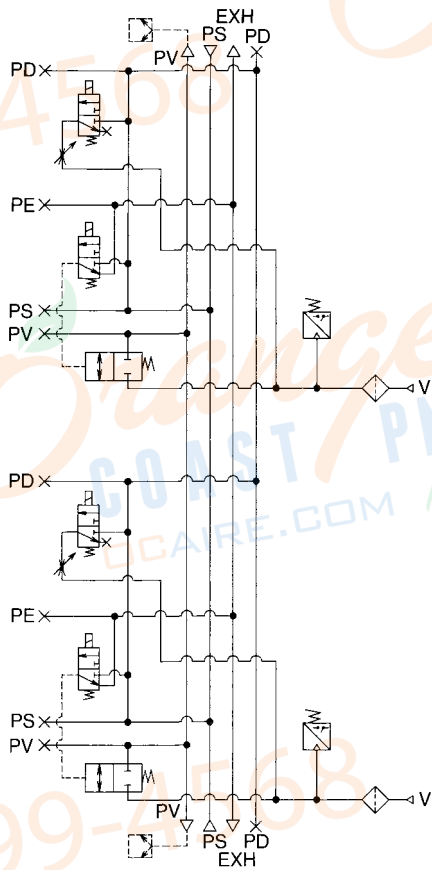

<System circuit example>

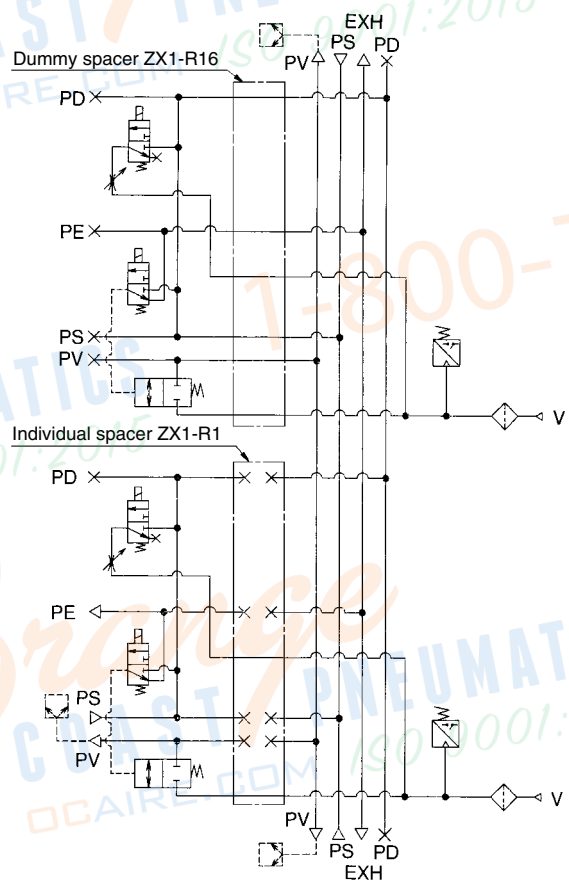

ZA
ZX
ZR
ZM
ZMA
ZQ
ZH
ZU
ZL
ZY□
ZF□
ZP□
SP
ZCUK
AMJ
AMV
AEP
HEP
Related Equipment

Series ZX

Vacuum Pump System Manifold

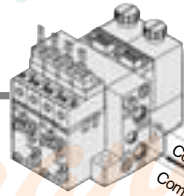

Common EXH port (EXH.)
Common pilot pressure SUP port (PS)
Common vacuum pressure SUP port (PV)

A: Release flow rate adjusting needle with lock nut

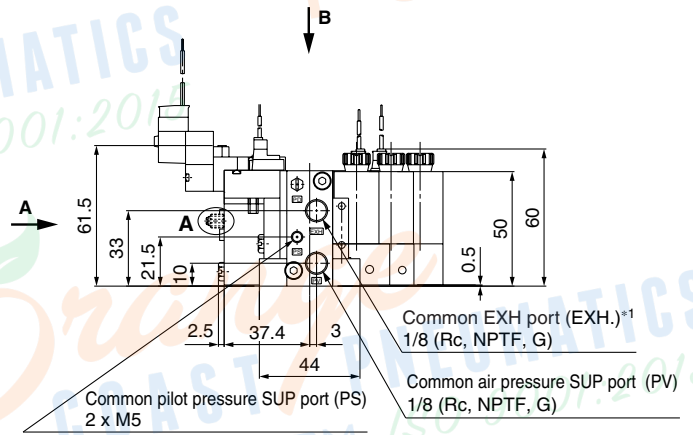
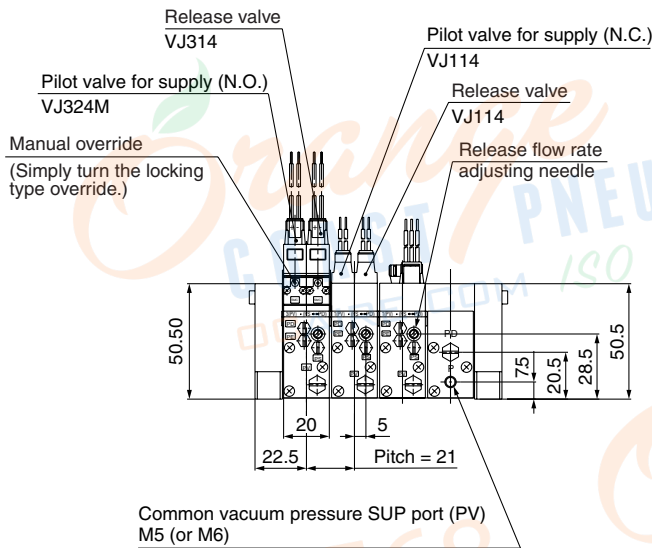
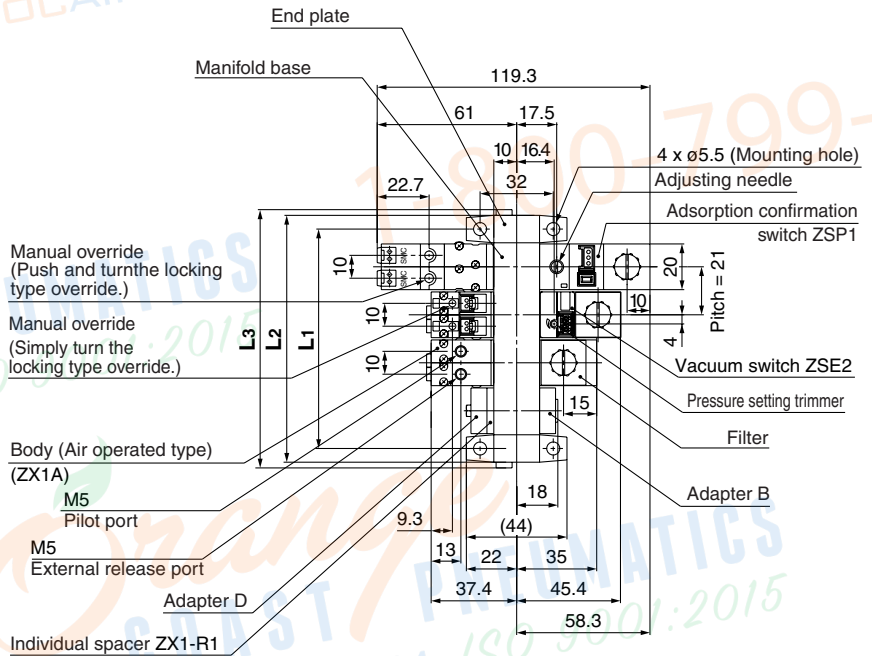
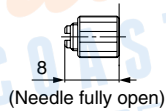

*1 The common exhaust port (EXH.) is also used as the pilot pressure exhaust (PE) port of pilot valve. Use while the port is open to the atmosphere.

		(mm)							
Symbol	Stations	1	2	3	4	5	6	7	8
L1		33	54	75	96	117	138	159	180
L2		45	66	87	108	129	150	171	192
L3		50	71	92	113	134	155	176	197

(In the case of individual spacer)

System circuit example

B cross section

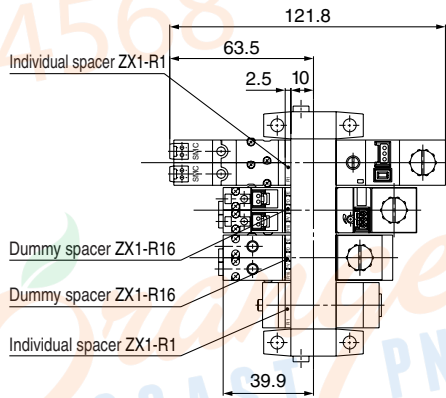

A cross section

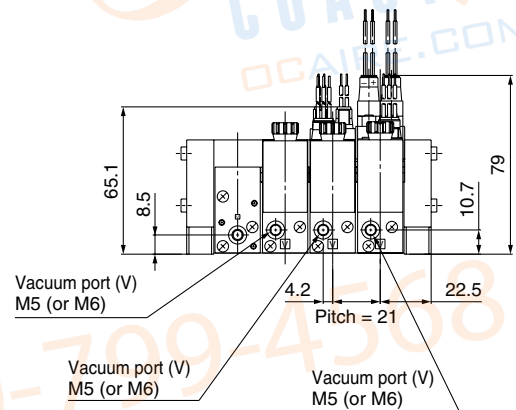
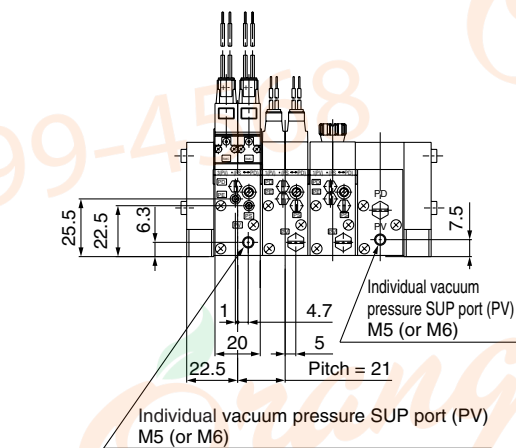

(Standard)

(Option)

(In the case of individual spacer)

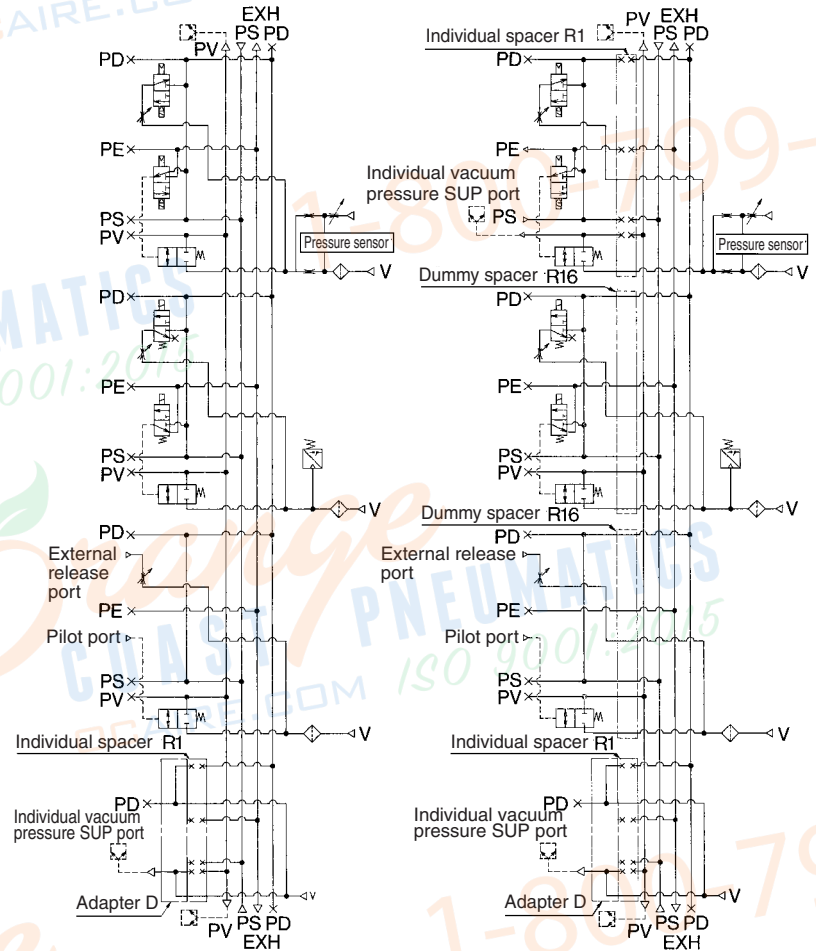

ZA
ZX
ZR
ZM
ZMA
ZQ
ZH
ZU
ZL
ZY□
ZF□
ZP□
SP
ZCUK
AMJ
AMV
AEP
HEP
Related Equipment

Series ZX

Vacuum Pump System Manifold: Type K1

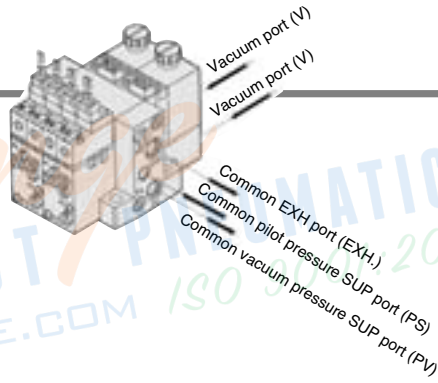

A: Release flow rate adjusting needle with lock nut

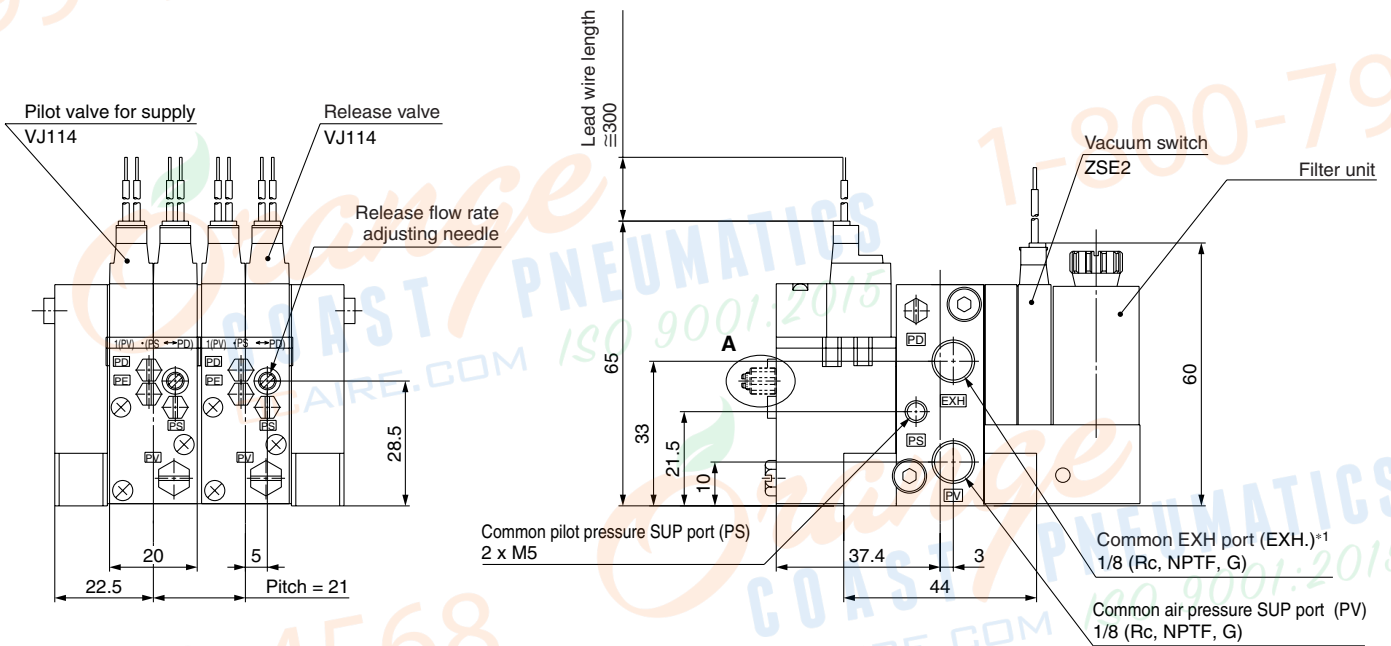
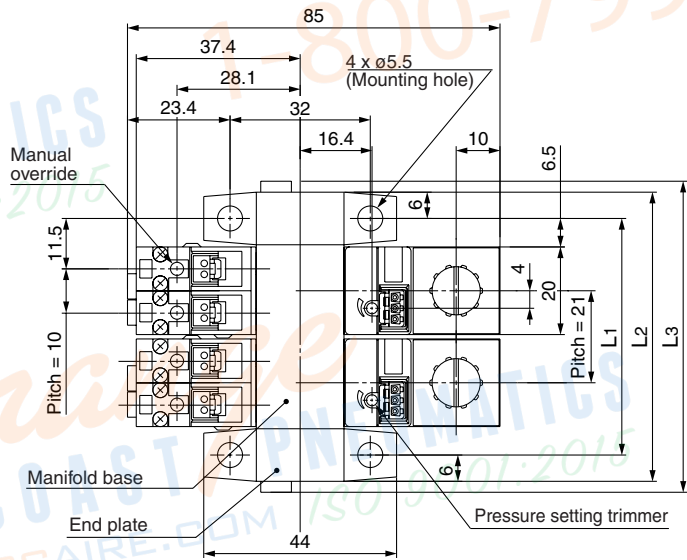
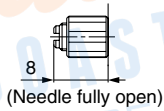

*1 The common exhaust port (EXH.) is also used as the pilot pressure exhaust (PE) port of pilot valve. Use while the port is open to the atmosphere.

		(mm)							
Symbol	Stations	1	2	3	4	5	6	7	8
L1		33	54	75	96	117	138	159	180
L2		45	66	87	108	129	150	171	192
L3		50	71	92	113	134	155	176	197

Circuit diagram

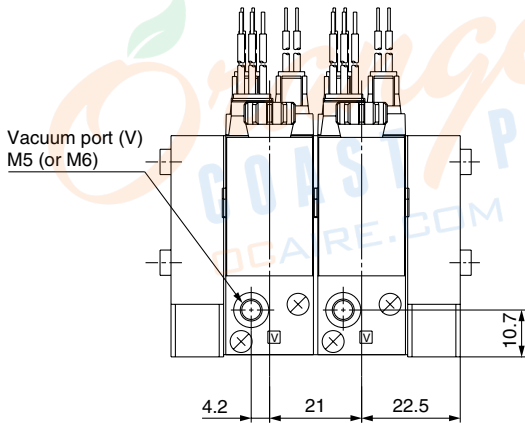
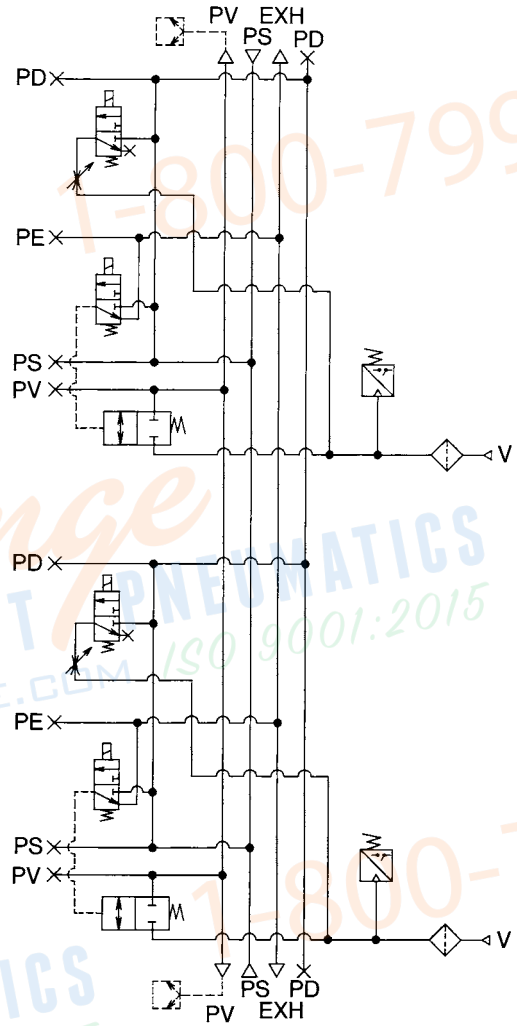

ZA
ZX
ZR
ZM
ZMA
ZQ
ZH
ZU
ZL
ZY□
ZF□
ZP□
SP
ZCUK
AMJ
AMV
AEP
HEP
Related Equipment

Series ZX

Vacuum Pump System Manifold: Type K3

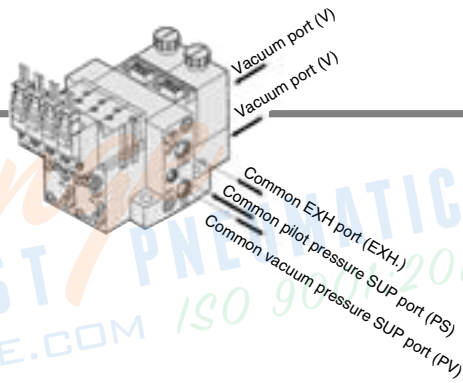

A: Release flow rate adjusting needle with lock nut

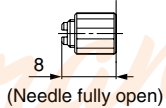

Manual override
(Push and turn the locking type override.)

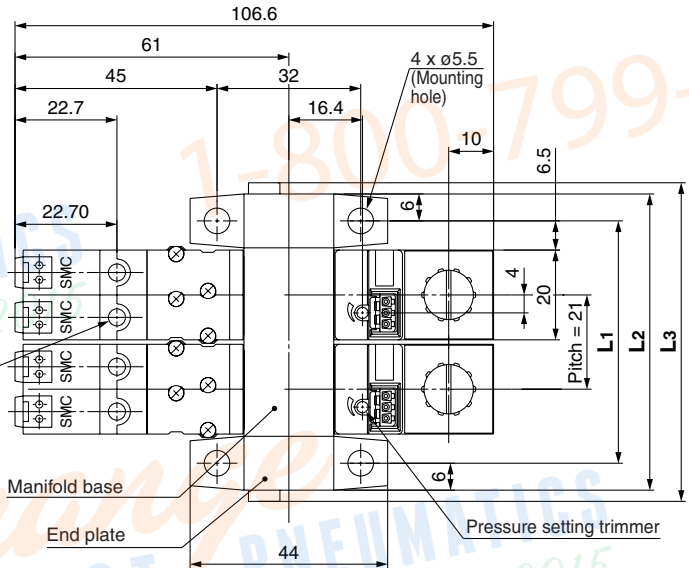

Pilot valve for supply (N.O.)
VJ324M

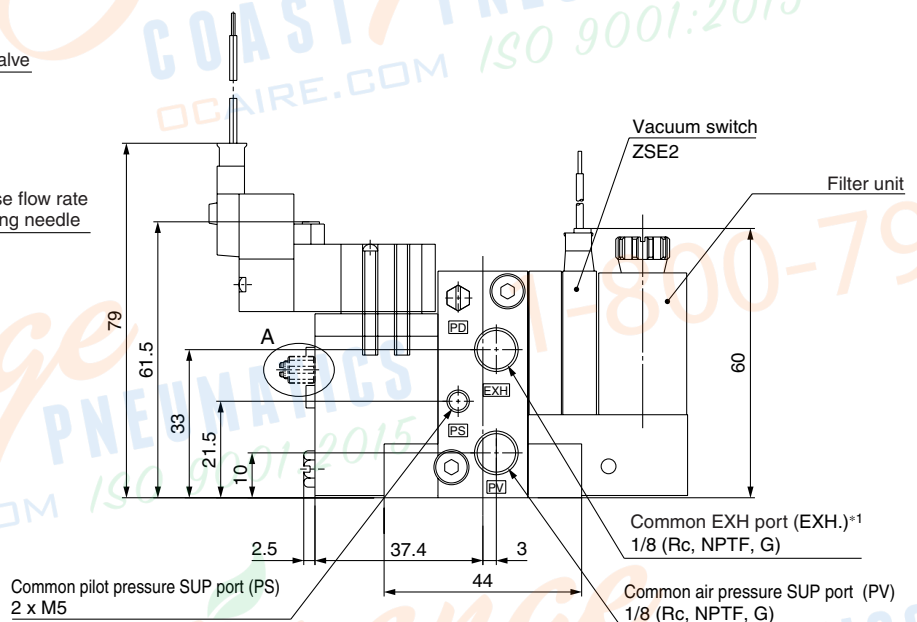
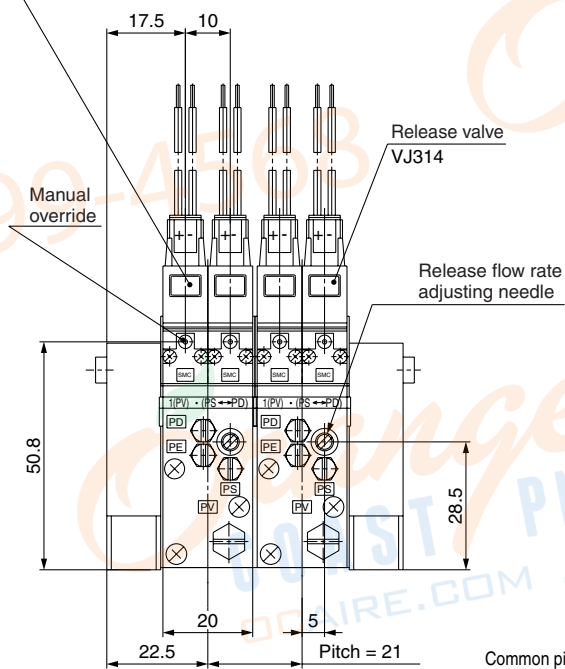

*1 The common exhaust port (EXH.) is also used as the pilot pressure exhaust (PE) port of pilot valve. Use while the port is open to the atmosphere.

Symbol	Stations	1	2	3	4	5	6	7	8
L1		33	54	75	96	117	138	159	180
L2		45	66	87	108	129	150	171	192
L3		50	71	92	113	134	155	176	197

Circuit diagram

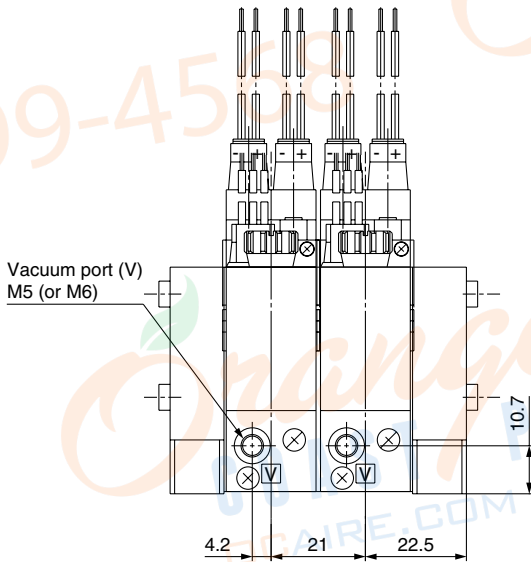
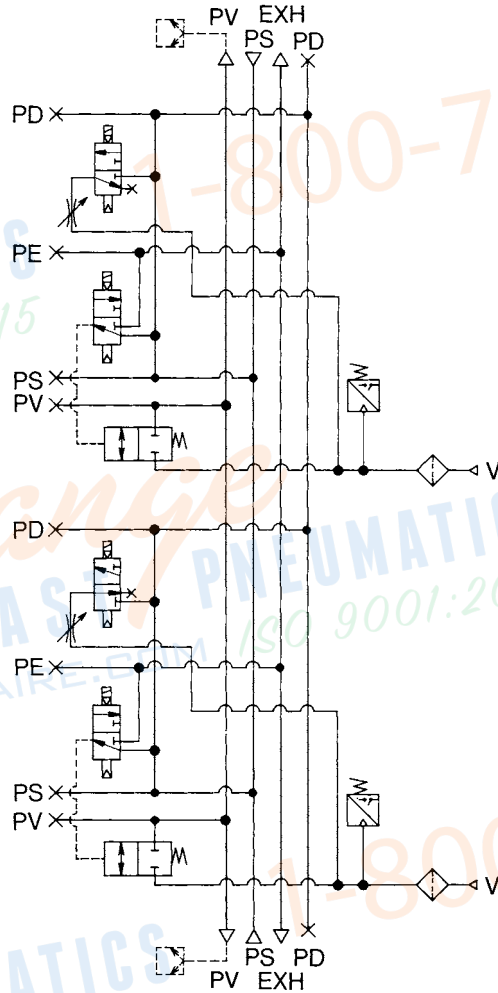

ZA
ZX
ZR
ZM
ZMA
ZQ
ZH
ZU
ZL
ZY□
ZF□
ZP□
SP
ZCUK
AMJ
AMV
AEP
HEP
Related Equipment

Series ZX

Ejector System/Unit Construction (Refer to below for unit replacement.)

Single

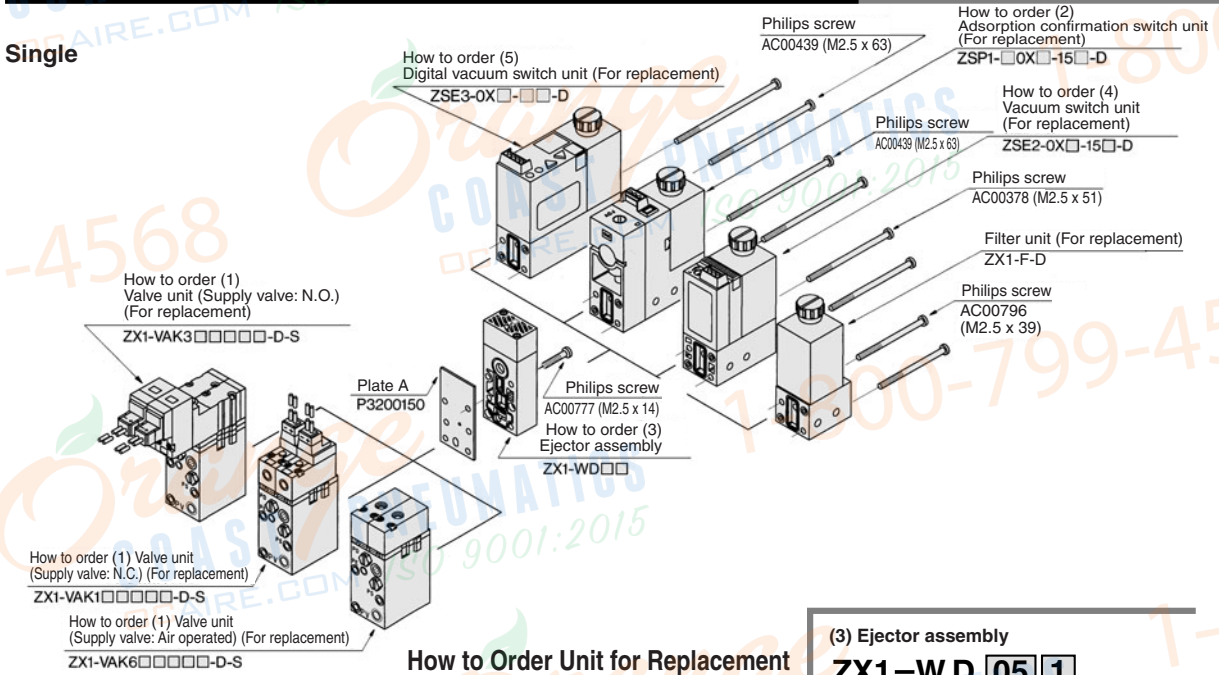

How to Order Unit for Replacement

(3) Ejector assembly

ZX1-W D 05 1

Unit for replacement	Nozzle diameter	Ejector exhaust
Nil	05 0.5 mm	1 Built-in silencer
Q CE compliant	07 0.7 mm	2 Port exhaust Rc 1/8
Single (PD and PS ports are equipped with plugs.)	10 1.0 mm	

(1) Valve unit

ZX1-V A K1 5 L Z B - L - D - S

For ejector system
Combination of supply valve and release valve
(Refer to page 867 for details.)

Pilot valve

Nil	DC: 1 W (With indicator light: 1.05 W) AC
Y*	DC: 0.45 W (With indicator light: 0.5 W)

* Only 24 VDC and 12 VDC are applicable to 0.45 W.

Solenoid valve rated voltage

	CE compliant
1* 100 VAC 50/60 Hz	—
3* 110 VAC 50/60 Hz	—
5 24 VDC	●
6 12 VDC	●
V 6 VDC	●
S 5 VDC	●
R 3 VDC	●

* Applicable to plug connector only. (Connector assembly with rectifier is attached.)

(2) Adsorption confirmation switch unit

ZSP1-B OX □ - 15 C - D

Applicable nozzle diameter

S	0.3 to 0.7mm
B	0.5 to 1.2mm

Piping specifications

Nil	Grommet (0.6 m)
L	Grommet (3 m)
C	Connector (0.6 m)
CL	Connector (3 m)
CN	Without connector

Release flow rate adjusting needle

Nil	Without lock nut
L	With lock nut

PV port size

Nil	M5 x 0.8
Y	M6 x 1 (Option)

Manual operation

Nil	Non-locking push type
B	Locking slotted type

Light/Surge voltage suppressor

Nil	None
Z	With light/surge voltage suppressor

Electrical entry

L	L plug connector
---	------------------

(5) Digital vacuum switch unit

ZSE3-0X □ - 21 C - D

Output specifications

21	2 outputs/without analog output
22	2 outputs/with analog output
23	1 output (with trouble detection)/without analog output
24	1 output (with trouble detection)/with analog output

Note) Analog output is available only on grommet type.

Piping specifications

Nil	Grommet (0.6 m)
L	Grommet (3 m)
C	Connector (0.6 m)
CL	Connector (3 m)
CN	Without connector

D: Unit for replacement.

Ex.) If an adsorption confirmation switch is replaced for a vacuum switch on ZX1071-K15LZ-PBC, indicate as ZSE2-0X-15C-D. In this case, mounting screws AC00378 (M2.5 x 51) (2 pcs.) are required.

If the unit is used on its own, not combined with others, "D" is not required. (Valve unit, ejector assembly and switch unit)

Ex.) ZSE2-0X-15C, ZX1-VAK15LZ, ZX1-W051

Series ZX

Vacuum Pump System/Unit Construction (Refer to below for unit replacement.)

Single

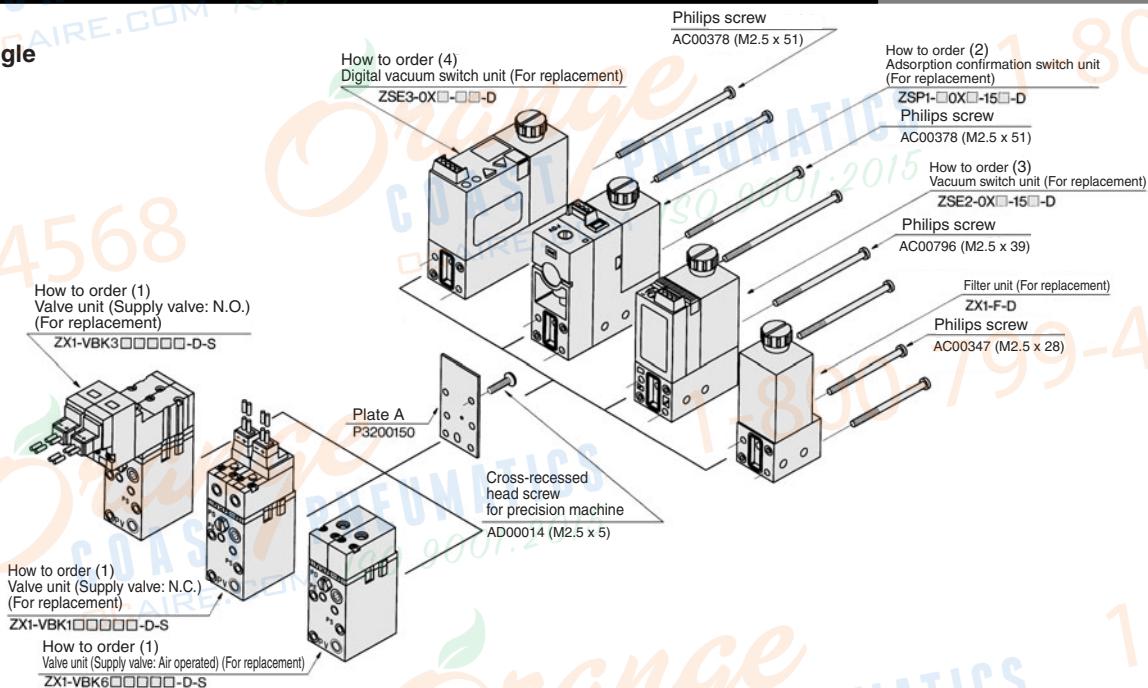

How to Order Unit for Replacement

(1) Valve unit

ZX1-V B K1 □ 5 L Z B □ - L - D - S - □

Vacuum pump for system
Combination of supply valve and release valve
(Refer to page 903 for details.)

Pilot valve

Nil	DC: 1 W (With indicator light: 1.05 W)
AC	
Y *	DC: 0.45 W (With indicator light: 0.5 W)

* Only 24 VDC and 12 VDC are applicable to 0.45 W.

Solenoid valve rated voltage

	CE compliant
1 *	100 VAC 50/60 Hz
3 *	110 VAC 50/60 Hz
5	24 VDC
6	12 VDC
V	6 VDC
S	5 VDC
R	3 VDC

* Applicable to plug connector only.
(Connector assembly with rectifier is attached.)

D: Unit for replacement
Ex.) If an adsorption confirmation switch is replaced for a vacuum switch on ZX100-K15LZ-PBC, indicate as ZSE2-0X-15C-D. In this case, mounting screws AC00796 (M2.5 x 39) are required.
If the unit is used on its own, not combined with others, "D" is not required.
Ex.) ZSE2-0X-15C, ZX1-VBK15LZ

(2) Adsorption confirmation switch unit

ZSP1-B0X □ - 15 C - D

Unit for replacement (PD port is equipped with plug.)

Nil	—
Q	CE compliant

Release flow rate adjusting needle

Nil	Without lock nut
L	With lock nut

PV port size

Nil	M5 x 0.8
Y	M6 x 1 (Option)

Manual operation

Nil	Non-locking push type
B	Locking slotted type

Light/Surge voltage suppressor

Nil	None
Z	With light/surge voltage suppressor

Electrical entry

L	L plug connector
---	------------------

Applicable nozzle diameter

S	0.3 to 0.7 mm
B	0.5 to 1.2 mm

Piping specifications

Nil	Grommet (0.6 m)
L	Grommet (3 m)
C	Connector (0.6 m)
CL	Connector (3 m)
CN	Without connector

(3) Vacuum switch unit

ZSE2-0X □ - 15 C - D

Output specifications

15	NPN open collector
55	PNP open collector

Unit for replacement

Piping specifications

Nil	Grommet (0.6 m)
L	Grommet (3 m)
C	Connector (0.6 m)
CL	Connector (3 m)
CN	Without connector

(4) Digital vacuum switch unit

ZSE3-0X □ - 21 C - D

Unit for replacement

Piping specifications

Nil	Grommet (0.6 m)
L	Grommet (3 m)
C	Connector (0.6 m)
CL	Connector (3 m)
CN	Without connector

Output specifications

21	2 outputs/without analog output
22	2 outputs/with analog output
23	1 output (with trouble detection)/without analog output
24	1 output (with trouble detection)/with analog output

Note) Analog output is available only on grommet type.

Series ZX

Vacuum Pump System/Manifold Assembly from Individual Unit

Manifold Assembly from individual unit

1. Remove Philips screws.
2. Remove cross-recessed head machine screw for precision machinery.
3. Mount plugs to valve unit.
4. Mount valve unit with Philips screws AC00347 (M2.5 x 28) 3 pcs.
5. Mount vacuum switch to manifold with Philips screws 2 pcs.
Follow tightening screw torque on Table (1).

Note 1)

Even though screw type in use differs depending on the combination (Table (2)), screws for an individual unit and a manifold are common.

Table (2)

Combination	Part no.
Vacuum switch ZSE3, ZSP1	AC00378 (M2.5 x 51)
Vacuum switch ZSE2	AC00796 (M2.5 x 39)
Filter unit ZX1-F	AC00347 (M2.5 x 28)

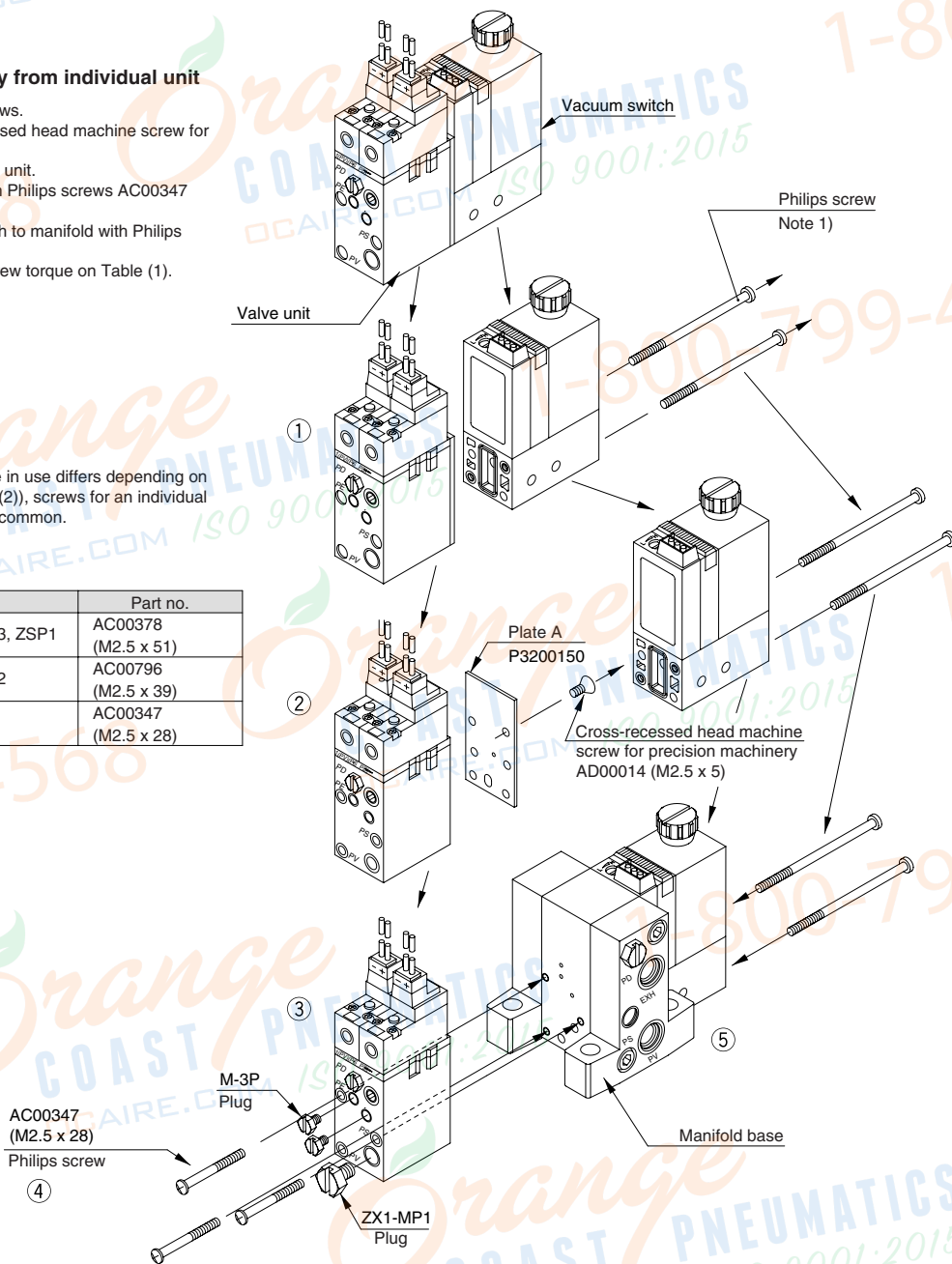

Table (1)

Part no.	Description	Quantity	Recommended tightening screw torque	In the case of manifold	Single unit
Note 1)	Philips screw	2	0.28 ± 0.1 (N·m)	Necessary	Necessary
P3200150	Plate A	1		Not necessary	Necessary
AD00014 (M2.5 x 5)	Cross-recessed head machine screw for precision machinery	1	0.28 ± 0.1 (N·m)	Not necessary	Necessary
M-3P	Plug	2	0.46 ± 0.05 (N·m)	Necessary	Not necessary
ZX1-MP1	Plug	1	1.6 ± 0.15 (N·m)	Necessary	Not necessary
AC00347 * (M2.5 x 28)	Philips screw	3	0.28 ± 0.1 (N·m)	Necessary	Not necessary

* Use AC00018 (M2.5 x 32) when individual spacers are used.

Ejector System/Manifold Assembly from Individual Unit

Manifold Assembly from individual unit

1. Remove Philips screws.
2. Remove Philips screws, and then remove ejector assembly from valve unit.
3. Mount plugs to valve unit.
4. Mount valve unit with Philips screws AC00347 (M2.5 x 28) 3 pcs.
5. Mount ejector assembly to manifold with Philips screw AC00777 (M2.5 x 14) 1 pc.
6. Mount vacuum switch to manifold with Philips screws 2 pcs.

Note 1)

Even though screw type in use differs depending on the combination (Table (2)), screws for an individual unit and a manifold are common. Follow tightening screw torque on Table (1).

Table (2)

Combination	Part no.
Vacuum switch ZSE3, ZSP1	AC00439 (M2.5 x 63)
Vacuum switch ZSE2	AC00378 (M2.5 x 51)
Filter unit ZX1-F	AC00796 (M2.5 x 39)

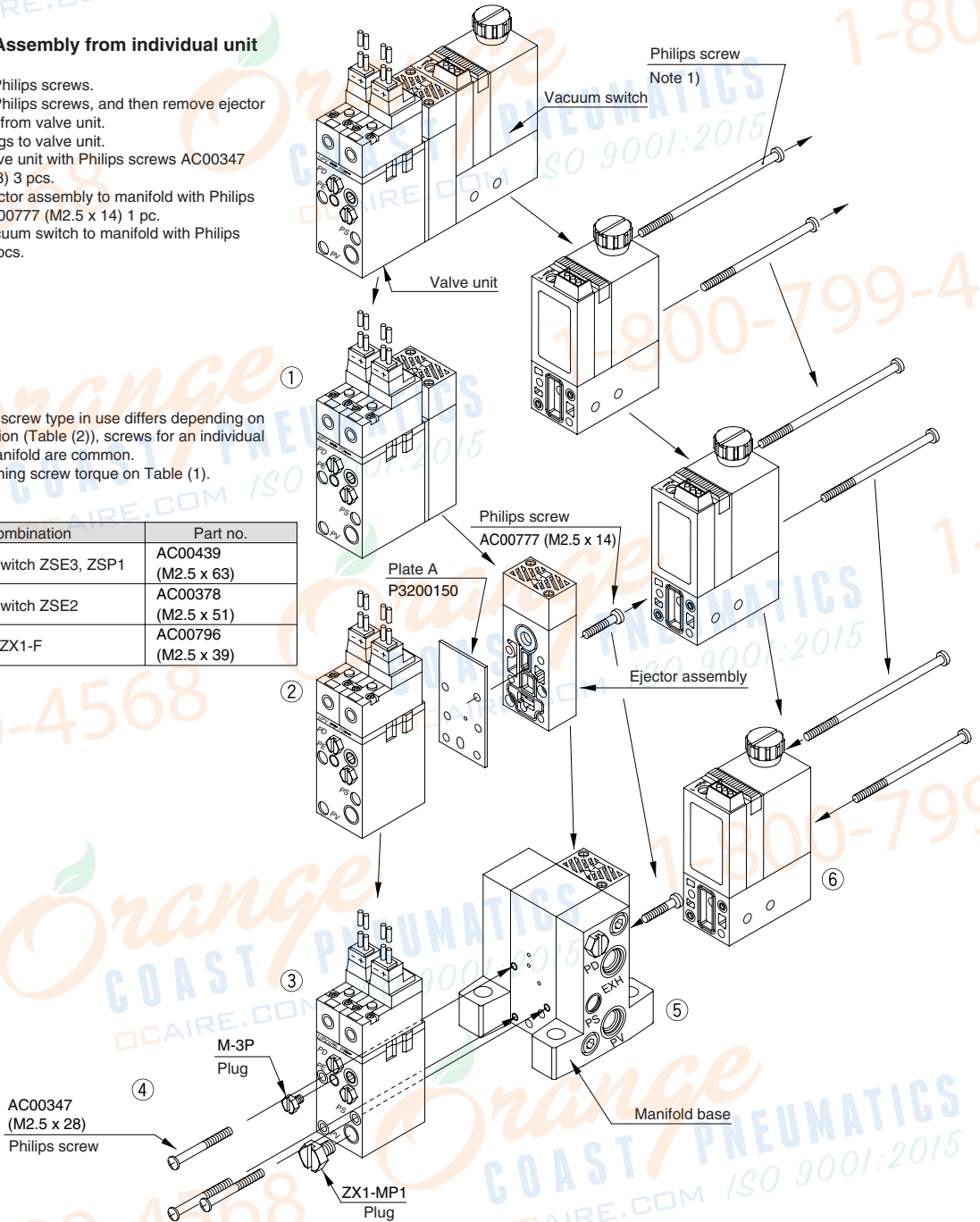

Table (1)

Part no.	Description	Quantity	Recommended tightening screw torque	In the case of manifold	Single unit
Note 1)	Philips screw	2	0.28 ± 0.1 (N·m)	Necessary	Necessary
P3200150	Plate A	1		Not necessary	Necessary
AC00777 (M2.5 x 14)	Philips screw	1	0.28 ± 0.1 (N·m)	Necessary	Necessary
M-3P	Plug	1	0.46 ± 0.05 (N·m)	Necessary	Not necessary
ZX1-MP1	Plug	1	1.6 ± 0.15 (N·m)	Necessary	Not necessary
AC00347 * (M2.5 x 28)	Philips screw	3	0.28 ± 0.1 (N·m)	Necessary	Not necessary

* Use AC00018 (M2.5 x 32) when individual spacers are used.

ZA
ZX
ZR
ZM
ZMA
ZQ
ZH
ZU
ZL
ZY□
ZF□
ZP□
SP
ZCUK
AMJ
AMV
AEP
HEP
Related Equipment



Please consult with SMC for detailed size, specifications and delivery.

1 Valve Unit/Other Combinations of Supply Valve and Release Valve (Ejector unit)

Ejector Unit

If those other than the standard combination of supply valves and release valves (Refer to page 867.) are required, select from the following combinations. (Refer to page 866 for "How to Order".)

Combination Symbol: K2

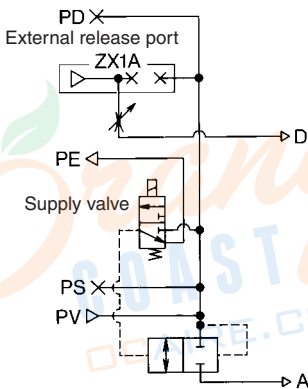

Application: The supply pressure is controlled by electric signals and a vacuum release is effected by external air.

How to Operate

Valve Condition	Supply valve	Release valve
	Solenoid valve	External 2 port valve
1. Work adsorption	ON	OFF
2. Vacuum release	OFF	ON
3. Operation stop	OFF	OFF

Combination Symbol: K7

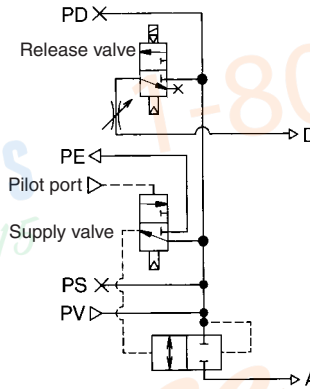

Application: The supply pressure is controlled by external air signals and a vacuum release is effected by the solenoid valve. Because the supply valve is N.O., the pressure that is supplied to the ejector is not interrupted during a power outage; as a result, the state of suction can be maintained. This combination is used for preventing the workpieces from dropping during power outages.

How to Operate

Valve Condition	Supply valve	Release valve
	Air operated valve	Solenoid valve
1. Work adsorption	OFF	OFF
2. Vacuum release	ON	ON
3. Operation stop	ON	OFF

Combination Symbol: K4

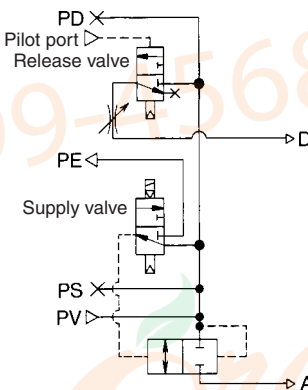

Application: The supply pressure is restricted by electric signals and a vacuum release is effected by air signals. Because the supply valve is N.C., the pressure that is supplied to the ejector is not interrupted during a power outage; as a result, the state of suction can be maintained. This combination is used for preventing the workpieces from dropping during power outages.

How to Operate

Valve Condition	Supply valve	Release valve
	Solenoid valve	Air operated valve
1. Work adsorption	OFF	OFF
2. Vacuum release	ON	ON
3. Operation stop	ON	OFF

Combination Symbol: J1

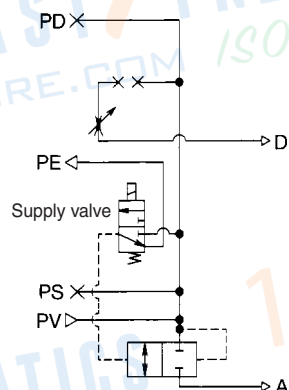

Application: This combination is used for effecting control in accordance with electric signals. A vacuum release is effected by the intrusion of air between the silencer, pad, and the workpiece. This combination is used when there is no need to accelerate the vacuum release speed.

How to Operate

Valve Condition	Supply valve	Release valve
	Solenoid valve	—
1. Work adsorption	ON	—
2. Vacuum release	OFF	—
3. Operation stop	OFF	—

Combination Symbol: K5

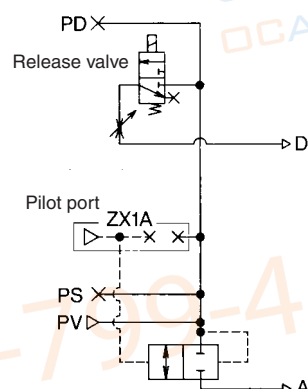

Application: The supply pressure is controlled by external air signals and a vacuum release is effected by the solenoid valve.

How to Operate

Valve Condition	Supply valve	Release valve
	External 3 port valve	Solenoid valve
1. Work adsorption	ON	OFF
2. Vacuum release	OFF	ON
3. Operation stop	OFF	OFF

Combination Symbol: J2

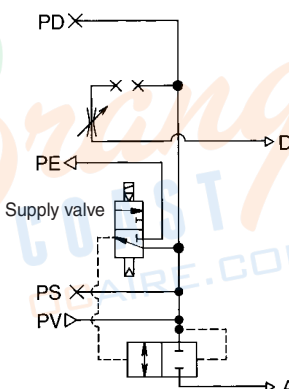

Application: It is used for controlling the supply pressure through electric signals. Because the supply valve is N.C., the pressure that is supplied to the ejector is not interrupted during a power outage; as a result, the state of suction can be maintained. This is used for preventing the workpieces from dropping during power outages. A vacuum release is effected by the intrusion of air between the silencer, pad, and the workpiece. This combination is used when there is no need to accelerate the vacuum release speed.

How to Operate

Valve Condition	Supply valve	Release valve
	Solenoid valve	—
1. Work adsorption	OFF	—
2. Vacuum release	ON	—
3. Operation stop	ON	—

Combination Symbol: J3

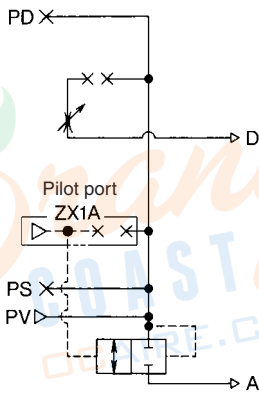

Application: The supply pressure is controlled by external air signals. A vacuum release is effected by the intrusion of air between the silencer, pad, and the workpiece. This is used when there is no need to accelerate the vacuum release speed.

How to Operate

Condition	Valve	Supply valve	Release valve
	External 3 port valve		
1. Work adsorption		ON	—
2. Vacuum release		OFF	—
3. Operation stop		OFF	—

Combination Symbol: J4

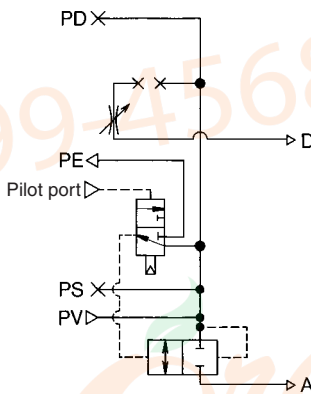

Application: The supply pressure is controlled by external air signals. Because the supply valve is N.O., the pressure that is supplied to the ejector is not interrupted during a power outage; as a result, the state of suction can be maintained. This is used for preventing the workpieces from dropping during power outages. A vacuum release is effected by the intrusion of air between the silencer, pad, and the workpiece. This type is used when there is no need to accelerate the vacuum release speed.

How to Operate

Condition	Valve	Supply valve	Release valve
	Air operated valve		
1. Work adsorption		OFF	—
2. Vacuum release		ON	—
3. Operation stop		OFF	—

Combination Symbol: D1

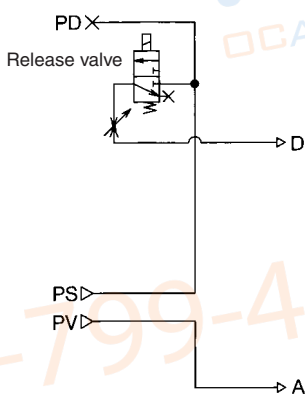

Application: The supply pressure is controlled by the external valve and a vacuum release is effected by the solenoid valve.

How to Operate

Condition	Valve	Supply valve	Release valve
	External valve	Solenoid valve	
1. Work adsorption		ON	OFF
2. Vacuum release		OFF	ON
3. Operation stop		OFF	OFF

Combination Symbol: D2

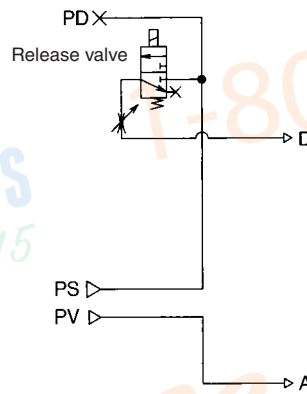

Application: The supply pressure is controlled by the external valve and a vacuum release is effected by the solenoid valve.

How to Operate

Condition	Valve	Supply valve	Release valve
	External valve	Solenoid valve	
1. Work adsorption		ON	OFF
2. Vacuum release		OFF	ON
3. Operation stop		OFF	OFF

Combination Symbol: D3

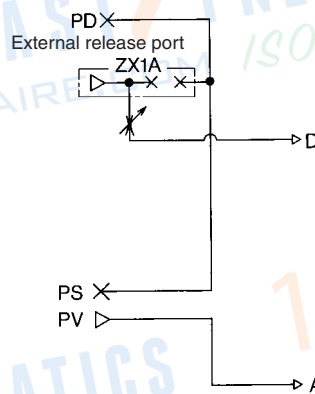

Application: The supply pressure is controlled by the external valve and a vacuum release is effected by the external 2 port valve (vacuum valve).

How to Operate

Condition	Valve	Supply valve	Release valve
	External valve	Solenoid valve	
1. Work adsorption		ON	OFF
2. Vacuum release		OFF	ON
3. Operation stop		OFF	OFF

Combination Symbol: D4

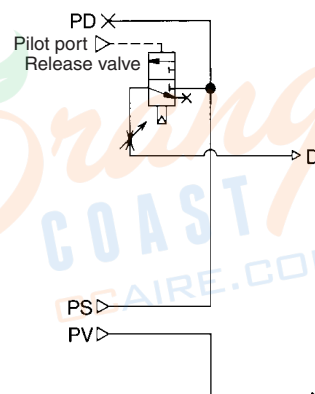

Application: The supply pressure is controlled by the external valve and a vacuum release is effected by external air signals.

How to Operate

Condition	Valve	Supply valve	Release valve
	External valve	Air operated valve	
1. Work adsorption		ON	OFF
2. Vacuum release		OFF	ON
3. Operation stop		OFF	OFF

ZA

ZX

ZR

ZM

ZMA

ZQ

ZH

ZU

ZL

ZY□

ZF□

ZP□

SP

ZCUK

AMJ

AMV

AEP

HEP

Related Equipment



Please consult with SMC for detailed size, specifications and delivery.

2 Valve Unit/Other Combinations of Supply Valve and Release Valve (Vacuum pump system)

Vacuum Pump System

If those other than the standard combination of supply valves (Refer to page 903.) and release valves are required, select from the following combinations. (Refer to page 902 for "How to Order".)

Combination Symbol: K2

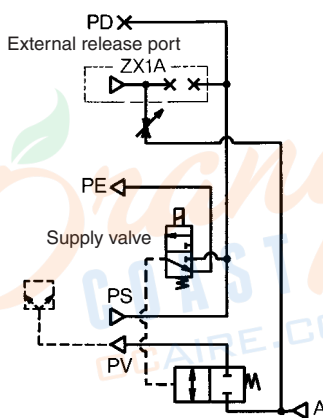

Application: The supply pressure is controlled by electric signals and a vacuum release is effected by external air.

How to Operate

Valve	Supply valve	Release valve
Condition	Solenoid valve	External 2 port valve
1. Work adsorption	ON	OFF
2. Vacuum release	OFF	ON
3. Operation stop	OFF	OFF

Combination Symbol: K7

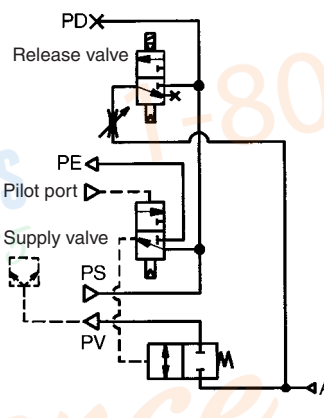

Application: The supply pressure is controlled by external air signals and a vacuum release is effected by the solenoid valve. Because the supply valve is the N.O., the pressure that is supplied to the ejector is not interrupted during a power outage; as a result, the state of suction can be maintained. This combination is used for preventing the workpieces from dropping during power outages.

How to Operate

Valve	Supply valve	Release valve
Condition	Air operated valve	Solenoid valve
1. Work adsorption	OFF	OFF
2. Vacuum release	ON	ON
3. Operation stop	ON	OFF

Combination Symbol: K4

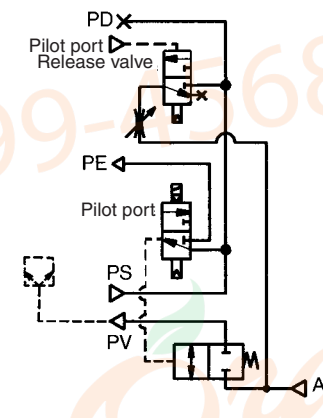

Application: The supply pressure is controlled by electric signals and a vacuum release is effected by air signals. Because the supply valve is N.O., the pressure that is supplied to the ejector is not interrupted during a power outage; as a result, the state of suction can be maintained. This combination is used for preventing the workpieces from dropping during power outages.

How to Operate

Valve	Supply valve	Release valve
Condition	Solenoid valve	Solenoid valve
1. Work adsorption	OFF	OFF
2. Vacuum release	ON	ON
3. Operation stop	ON	ON

Combination Symbol: J1

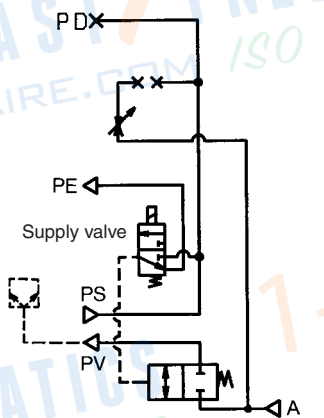

Application: This combination is used for controlling the pressure by electric signals. Normally, the workpiece is released due to the air leakage that occurs between the pad and the workpiece. However, if there is no air leakage, the workpiece will not become detached because the vacuum state is maintained even when the supply valve is turned OFF. To effect releasing, an external 2 port valve (vacuum valve) must be provided.

How to Operate

Valve	Supply valve	Release valve
Condition	Solenoid valve	—
1. Work adsorption	ON	—
2. Vacuum release	OFF	—
3. Operation stop	OFF	—

Combination Symbol: K5

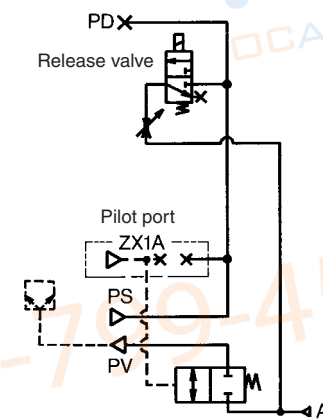

Application: The supply pressure is controlled by external air signals and a vacuum release is effected by the solenoid valve.

How to Operate

Valve	Supply valve	Release valve
Condition	External 3 port valve	Solenoid valve
1. Work adsorption	ON	OFF
2. Vacuum release	OFF	ON
3. Operation stop	OFF	OFF

Combination Symbol: J2

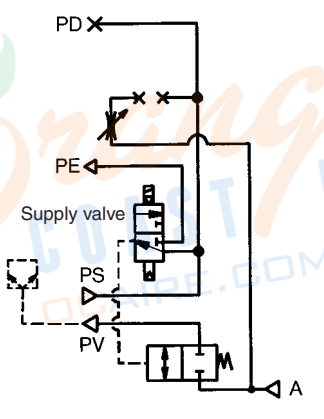

Application: Used for controlling with electric signals. Because the supply N.O., the pressure is not interrupted during a power outage. This prevents the workpieces from dropping. Normally, the workpiece is released due to leakage. However, if no air leakage, the workpiece will not detach because the vacuum state is maintained even when the supply valve is turned ON. To release, an external 2 port valve (vacuum valve) must be used.

How to Operate

Valve	Supply valve	Release valve
Condition	Solenoid valve	—
1. Work adsorption	OFF	—
2. Vacuum release	ON	—
3. Operation stop	ON	—

Combination Symbol: J3

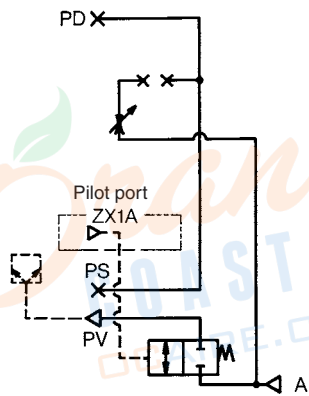

Application: The supply pressure is controlled by external air signals. Normally, the workpiece is released due to the air leakage that occurs between the pad and the workpiece. However, if there is no air leakage, the workpiece will not become detached because the vacuum state is maintained even when the supply valve is turned OFF. To effect releasing, an external 2 port valve (vacuum valve) must be provided.

How to Operate

Valve	Supply valve	Release valve
	External 3 port valve	—
Condition		
1. Work adsorption	ON	—
2. Vacuum release	OFF	—
3. Operation stop	OFF	—

Combination Symbol: D2

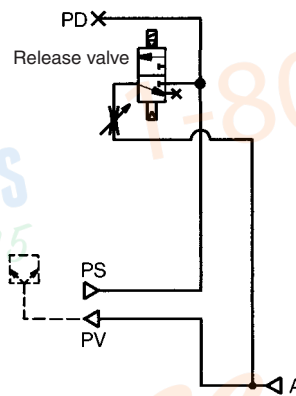

Application: The supply pressure is controlled by an external 2 port valve (vacuum valve) and a vacuum release is effected by the solenoid.

How to Operate

Valve	Supply valve	Release valve
	External 2 port valve	Solenoid valve
Condition		
1. Work adsorption	ON	OFF
2. Vacuum release	OFF	ON
3. Operation stop	OFF	OFF

Combination Symbol: J4

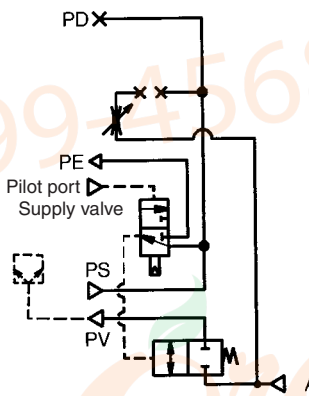

Application: Supply is controlled by external air signals. Because the valve is N.O., the pressure is not interrupted during a power outage. This prevents the workpieces from dropping. Normally, the workpiece is released due to leakage. However, if no leakage, the workpiece will not detach because the vacuum state is maintained even when the valve is turned ON. To release, an external 2 port valve (vacuum valve) must be provided.

How to Operate

Valve	Supply valve	Release valve
	Air operated valve	—
Condition		
1. Work adsorption	OFF	—
2. Vacuum release	ON	—
3. Operation stop	ON	—

Combination Symbol: D3

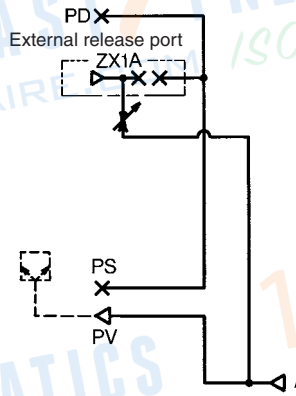

Application: The supply pressure is controlled by the external 2 port valve (vacuum valve) and releasing is also effected by the external 2 port valve.

How to Operate

Valve	Supply valve	Release valve
	External 2 port valve	Solenoid valve
Condition		
1. Work adsorption	ON	OFF
2. Vacuum release	OFF	ON
3. Operation stop	OFF	OFF

Combination Symbol: D1

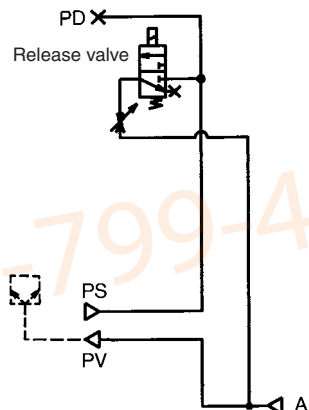

Application: The supply pressure is controlled by an external 2 port valve (vacuum valve) and a vacuum release is effected by the solenoid.

How to Operate

Valve	Supply valve	Release valve
	External 2 port valve	Solenoid valve
Condition		
1. Work adsorption	ON	OFF
2. Vacuum release	OFF	ON
3. Operation stop	OFF	OFF

Combination Symbol: D4

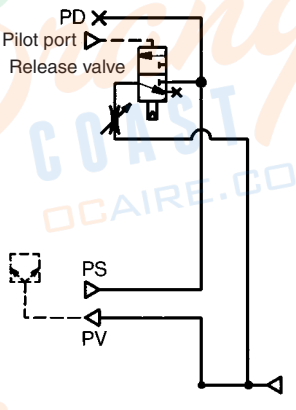

Application: The supply pressure is controlled by the external 2 port valve (vacuum valve) and vacuum release is effected by external air signals.

How to Operate

Valve	Supply valve	Release valve
	External 2 port valve	Solenoid valve
Condition		
1. Work adsorption	ON	OFF
2. Vacuum release	OFF	ON
3. Operation stop	OFF	OFF

ZA

ZX

ZR

ZM

ZMA

ZQ

ZH

ZU

ZL

ZY□

ZF□

ZP□

SP

ZCUK

AMJ

AMV

AEP

HEP

Related Equipment

Made to Order Specifications:



Please consult with SMC for detailed size, specifications and delivery.



3 High Noise Reduction Silencer Assembly

ZX1 [Nozzle diameter] [Exhaust style] — [Valve] [Voltage] [Electrical entry] [X121] — [CE compliant]

High noise reduction silencer assembly

Reduction in the exhaust noise from the ejector (Silencing effect 8 dB (A) Standard silencer assembly comparison)

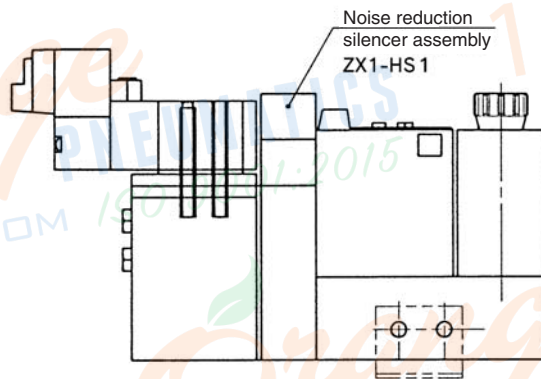

Ordering example
ZX1101-K35LZ-D23C-X121

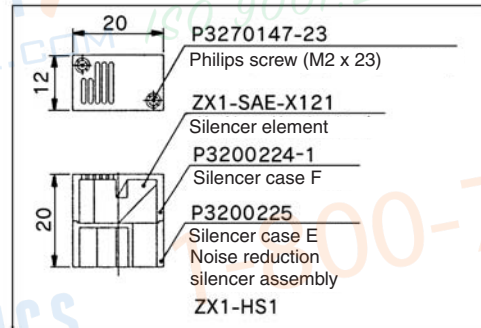

Noise reduction silencer assembly ZX1-HS 1

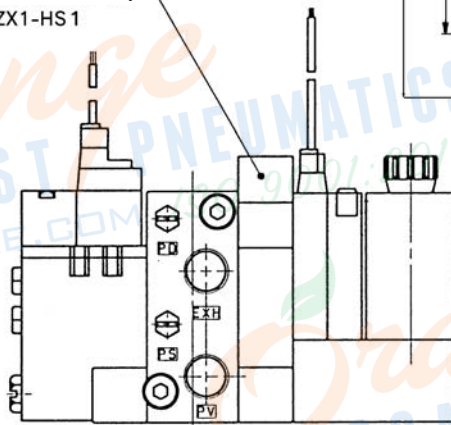

Ordering example
ZZX102-R
* ZX1101-K15LZ-EC-X121

1 pc.
2 pcs.