



**PETER
PAUL**

electronics co., inc.

World Class Solenoid Valves



Excellence By Control



**PETER
PAUL**

We at Peter Paul put a heavy emphasis on the word *quality*. In describing our products, quality is the most important term. One of the rewards of being in a specialized business like ours for over 35 years is a thorough knowledge of all the facets of manufacturing and development of superior valves and operators.

Peter Paul has kept pace with every improvement that has been made available both in material and techniques. Our fully staffed design, research and development departments consistently bring new exciting products to the world's marketplace.

Accurate, high speed manufacturing, top quality components are only part of the picture. Dedication to customers' needs, both in service and delivery, is a very significant quality. Our sales department is ready to answer questions and solve problems. Please feel free to call.

The Peter Paul people are proud of their growth, their business vitality, their reputation, and their products.



Paul S. Mangiafico
President



Michael Mangiafico
Executive Vice President



Josephine Mangiafico
Secretary / Treasurer



Mark Mangiafico
Chief Engineer



Richard Ronzello
Sales Manager



77,000 sq. ft. New Britain, Connecticut facility



23,500 sq. ft. Fajardo, Puerto Rico facility

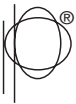

TABLE OF CONTENTS

PRODUCT GUIDE (pages 4-5)

GENERAL PURPOSE VALVES (pages 6-21)

Series 15 6-7

Series 20, 30, 50 & 70

 Two Way Normally Open 8-9

 Two Way Normally Closed 10-11

 Three Way Normally Closed (Exhaust to Atmosphere) 12-13

 Three Way Normally Closed (Piped Exhaust) 14-15

 Three Way Normally Open 16-17

 Three Way Directional Control 18-19

 Three Way Multi Purpose 20-21

EXPLOSION PROOF VALVES / LOW WATT VALVES & HIGH PRESSURE VALVES (pages 22-39)

 Series 20 (Explosion Proof) Two Way and Three Way Valves 22-23

 Series 20 (Explosion Proof) Three Way Valves 24-25

 Series 20 (Explosion Proof / High Pressure) Two Way Normally Open 26-27

 Series 20 (Explosion Proof / High Pressure) Two Way Normally Closed 28-29

 Series 20 (Explosion Proof / High Pressure) Three Way Normally Closed 30-31

 Series 50 EW Explosion Proof 32-33

 Series E50 Miniature-Explosion Proof 34-35

 Series EL50 Miniature Explosion Proof / Low Watt 36-37

 Series 50 ELW & ELLW Explosion Low Watt 38-39

LOW WATT VALVES (pages 40-43)

 Series 50 SLW & SLLW Super Low Watt 40-41

 Series 50 LW & LLW Low Watt 42-43

 Series S58 Uprated Pressure 44-45

PLASTIC BODY VALVES (pages 44-49)

 Series 58 Mini Valve & Pilot Operators 46-47

 Series 40 Plastic Valves 48-49

HIGH FLOW VALVES (pages 50-53)

 Series 20 High Flow Low Pressure 50

 Series 70 High Flow 51

 Series 80 Large Orifice 52-53

SPECIAL APPLICATIONS (pages 54-59)

 Series 30 Model F32 Filter Valve 54

 Series 50 Media Isolation Valve 55

 Series 20 Magnetic Latching Valve 56-57

SOLENOID OPERATORS 58-59

FEATURED SPECIALS (pages 60-76)

 Manifolds 61-62

 Seal Material 63-65

 Body Options 66-71

 Special Applications 71

 Coil Options 72-74

 Housing Options 75

MISCELLANEOUS OPTIONS, FILTER AND MUFFLERS 76-77

HOUSING & COIL OPTIONS 78-79

BODY & PORT OPTIONS 80-81

MAINTENANCE & CLEANING INSTRUCTIONS 82

INDUSTRY TERMS 83-92

MEDIA TABLE 93-94

FLOW CHARTS 95-97

SERIES 15 COIL CHART 98

SERIES 20 & 80 COIL CHART 99

SERIES 30 COIL CHART 100

SERIES 50 COIL CHART 101

SERIES 70 COIL CHART 102

AVAILABLE OPTIONS 103

NUMBERING SYSTEM CHART FOR SOLENOID OPERATORS 104

NUMBERING SYSTEM CHART FOR SERIES 58 105

NUMBERING SYSTEM CHART 106

SPECIFICATION FORM 003A 107

The physical portion of Peter Paul's operation consists of a 77,000 square foot plant in New Britain, Connecticut, and 23,500 square foot facility in Fajardo, Puerto Rico. These buildings are home to outstanding design, research / development, and manufacturing. The Peter Paul environment is more importantly an organization of people – people with years of experience, dedication and pride, people who bring you products that have a reputation for excellence.



Main Office, New Britain



Engineering



Lab



Model Shop



Tool Room



Multiple Spindle Screw Machines



CNC Machining



CNC Machining



CNC Machining



Machine Shop



Single Spindle Screw Machines



Computer Controlled Passivation Line



Welding



Inspection



Plunger Test



Assembly



Assembly Work Cell



Packing Room



Warehouse



Office, Puerto Rico



Coil Wrapping, Puerto Rico



**Bobbin Molding and other parts,
Puerto Rico**



Coil Winding, Puerto Rico



Coil Encapsulation, Puerto Rico

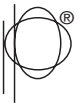

SOLENOID VALVES . . .

SERIES 58

Smallest in the line — low cost, low power consumption, high performance. Ideally suited for solid state controls.



2-WAY LEAD WIRES



2-WAY DIN CONNECTOR



3-WAY LEAD WIRES



3-WAY WITH MANUAL OVERRIDE DIN CONNECTOR

SERIES 15

The little black box — magnetic components encased in epoxy for durability and reliability. Interior parts are stainless steel and anodized aluminum.



MALE EXPORT STYLE DIN CONNECTOR



CONDUIT LEAD WIRES



3-WAY W/FEMALE DIN CONNECTOR



3-WAY LEAD WIRES

SERIES 50

Our original mini — engineered for space economy without sacrificing performance. Typical applications include medical, analytical instrumentation.



2-WAY CONDUIT



2-WAY GROMMET



3-WAY GROMMET



3-WAY CONDUIT

SERIES 30

Complete range of two-way and three-way valves particularly suitable when cost and size are major factors. The bodies are constructed of brass (2-way normally closed, brass or stainless steel is standard).



2-WAY CONDUIT



2-WAY GROMMET



3-WAY GROMMET



3-WAY CONDUIT

SERIES 20

A complete line of two-way and three-way valves with a great selection of options. Exceptional proven performance. The standard in the field.



2-WAY CONDUIT



2-WAY GROMMET



3-WAY GROMMET



3-WAY CONDUIT

SERIES 70

SUPER VALVES
2- and 3-way valves having ratings that formerly required valves of much greater size.



2-WAY CONDUIT



2-WAY GROMMET



3-WAY GROMMET



3-WAY CONDUIT

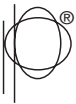

SOLENOID VALVES . . .

EXPLOSION PROOF For hazardous locations proven and tested to meet UL and CSA requirements. Safe and continuous operation at maximum pressures.



SERIES E80
INTERNAL PILOT PORT



SERIES E50
2-WAY



SERIES E20
3-WAY PIPED EXHAUST



SERIES EH20
HIGH PRESSURE IMPACT TYPE
2-WAY NORMALLY CLOSED



SERIES EH20
HIGH PRESSURE IMPACT TYPE
3-WAY NORMALLY CLOSED



SERIES EH20
HIGH PRESSURE IMPACT TYPE
2-WAY NORMALLY OPEN

HIGH PRESSURE Super high pressure ratings with bubble tight sealing. Ratings to 3000 psi.



SERIES EH20
HIGH PRESSURE EXPLOSION PROOF



SERIES 20
3-WAY NORMALLY CLOSED



SERIES 20
2-WAY NORMALLY CLOSED

HIGH FLOW Two-way, large orifice valves for dump or quick fill.



SERIES 70 HIGH FLOW
2-WAY NORMALLY CLOSED



SERIES 80



SERIES 80
INTERNAL PILOT



SERIES 80
DIRECT LIFT

The Little Black Box that meets the design and application challenges of modern industry

- SMALL
- LIGHTWEIGHT
- ECONOMICAL
- OPERATING PRESSURES FROM VACUUM TO 500 PSI
- QUALITY DESIGN AND CONSTRUCTION

Series 15 is U.L. and CSA Component listed for A.C. only.

This Series 15 valve group is available as 2-Way Normally Open, 2-Way Normally Closed, and a variety of 3-Way functional combinations to meet your application requirements.

The valves may be used with air, inert gas and liquid media at pressures from vacuum to 500 psi — depending upon orifice size and configuration.

Interior parts are stainless steel and anodized aluminum. All external magnetic components are encased in epoxy for durability and reliability.

For those who require extra heat resistance and media compatibility FKM and other elastomers are available.

Valve Temperature Range: STANDARD VALVES - 0°F (-18°C) to 104°F (40°C) ambient; 0°F (-18°C) to 150°F (65°C) media. OPTIONAL VALVES – can tolerate much higher or much lower ambient and media temperatures. Consult factory for specifics.

Standard valve porting is 1/8 NPT.

Nominal Power:

8.5 Watts AC

7.0 Watts AC (2 Way Normally Closed)

10.5 Watts DC

The entire coil and magnetic structure are epoxy encapsulated and rated for continuous duty.

The “Male Export Style DIN Connector”, 24" Lead Wire and Conduit configurations are standard.

For your convenience we have the female DIN style mating connector No. 50-17029 available.

Include voltage and frequency requirements at the end of the valve number for ordering purposes. (Example: 152G2DEM-120V/60HZ)

Valves weigh 4¼ oz. to 4¾ oz. (.27lb. to .30lb.) - depending upon particular model and trim.

Repair Packs—available, consult factory

Stackable Valves, brass and stainless steel round bodies available, consult factory.

FOR FLOW CHARTS SEE PAGES 95-97

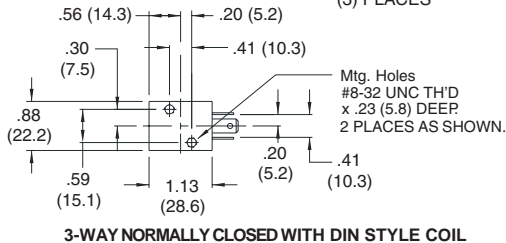
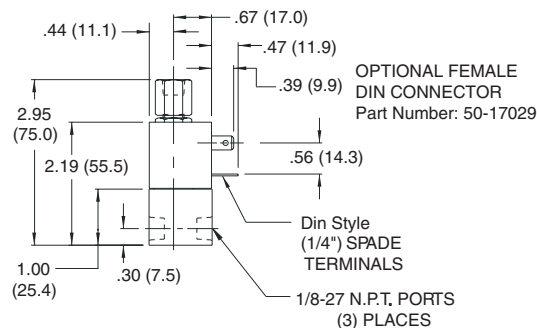
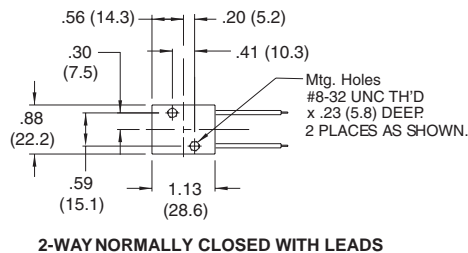
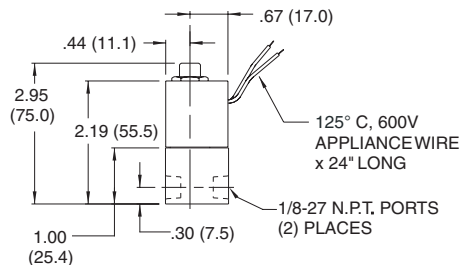
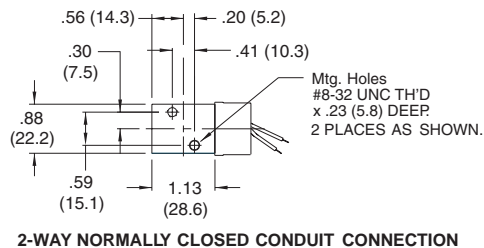
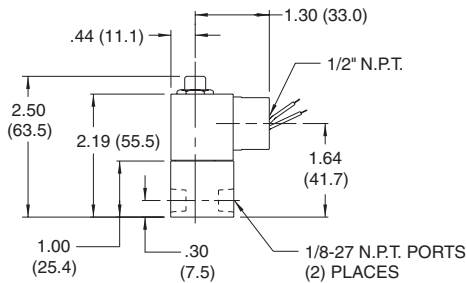

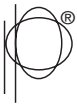

SOLENOID VALVES . . .

MODEL TYPE	FLOW CONFIGURATION	MAX. OPER. PRESS DIFF.		ORIFICE SIZE		CV FACTOR		LEAD WIRE UNIT	EXPORT STYLE CONNECTOR UNIT	CONDUIT HOUSING	
		AC	DC	INLET	EXH.	INLET	EXH.				
MODEL 151 2-Way Normally Open **	DE-ENERGIZED	ENERGIZED	400	400		1/32		.020	151G2XGM	151G2XEM	151G2XCM
			200	200		3/64		.048	151H2XGM	151H2XEM	151H2XCM
			125	125		1/16		.075	151J2XGM	151J2XEM ✓	151J2XCM
			40	40		3/32		.130	151K2XGM	151K2XEM	151K2XCM
MODEL 152 2-Way Normally Closed	DE-ENERGIZED	ENERGIZED	500	500	1/32		.022		152G2DGM	152G2DEM	152G2DCM
			400	400	3/64		.055		152H2DGM	152H2DEM	152H2DCM
			200	200	1/16		.075		152J2DGM ✓	152J2DEM	152J2DCM
			150	100	3/32		.130		152K2DGM	152K2DEM	152K2DCM
MODEL 153 3-Way Normally Closed ATMOSPHERE EXHAUST	DE-ENERGIZED	ENERGIZED	200	200	1/32	1/32	.022	.020	153GG2DGM	153GG2DEM	153GG2DCM
			150	150	3/64	3/64	.055	.048	153HH2DGM	153HH2DEM	153HH2DCM
			150	150	3/64	1/16	.055	.075	153HJ2DGM	153HJ2DEM	153HJ2DCM
			100	100	1/16	1/16	.075	.075	153JJ2DGM ✓	153JJ2DEM	153JJ2DCM
			60	60	3/32	1/16	.130	.075	153KJ2DGM	153KJ2DEM	153KJ2DCM
			50	50	3/32	3/32	.130	.130	153KK2DGM	153KK2DEM	153KK2DCM
MODEL 153 3-Way Normally Closed WITH PIPED EXHAUST **	DE-ENERGIZED	ENERGIZED	200	200	1/32	1/32	.022	.020	153GG2XGM	153GG2XEM	153GG2XCM
			150	150	3/64	3/64	.055	.048	153HH2XGM	153HH2XEM	153HH2XCM
			150	150	3/64	1/16	.055	.075	153HJ2XGM	153HJ2XEM	153HJ2XCM
			100	100	1/16	1/16	.075	.075	153JJ2XGM ✓	153JJ2XEM	153JJ2XCM
			60	60	3/32	1/16	.130	.075	153KJ2XGM	153KJ2XEM	153KJ2XCM
			50	50	3/32	3/32	.130	.130	153KK2XGM	153KK2XEM	153KK2XCM
MODEL 154 3-Way Normally Open **	DE-ENERGIZED	ENERGIZED	150	150	1/32	1/32	.020	.022	154GG2XGM	154GG2XEM	154GG2XCM
			125	125	3/64	3/64	.048	.055	154HH2XGM	154HH2XEM	154HH2XCM
			100	100	1/16	1/16	.075	.075	154JJ2XGM	154JJ2XEM	154JJ2XCM
			75	75	1/16	3/32	.075	.130	154JK2XGM	154JK2XEM	154JK2XCM
			50	50	3/32	3/32	.130	.130	154KK2XGM	154KK2XEM	154KK2XCM
MODEL 155 3-Way Directional Control **	DE-ENERGIZED	ENERGIZED	300	200	1/32*	1/32	.022*	.020	155GG2XGM	155GG2XEM	155GG2XCM
			200	150	3/64*	3/64	.055*	.048	155HH2XGM	155HH2XEM	155HH2XCM
			100	75	1/16*	1/16	.075*	.075	155JJ2XGM	155JJ2XEM	155JJ2XCM
			75	40	3/32*	1/16	.130*	.075	155KJ2XGM	155KJ2XEM	155KJ2XCM
			75	40	3/32*	3/32	.130*	.130	155KK2XGM	155KK2XEM	155KK2XCM
MODEL 156 3-Way Multi-purpose **	DE-ENERGIZED	ENERGIZED	125	125	1/32*	1/32	.022*	.020	156GG2XGM	156GG2XEM	156GG2XCM
			100	100	3/64*	3/64	.055*	.048	156HH2XGM	156HH2XEM	156HH2XCM
			65	50	1/16*	1/16	.075*	.075	156JJ2XGM	156JJ2XEM ✓	156JJ2XCM
			25	25	3/32*	3/32	.130*	.130	156KK2XGM	156KK2XEM	156KK2XCM

* Normally closed orifice.

** Pressure rating may change due to the viscosity of the liquid - consult factory for de-rating.

NOTE: The above checked (✓) Valves are most popular based on sales and likely to be in Distributor stock.

SPECIFICATIONS—2-WAY NORMALLY OPEN

OPERATING CONDITIONS

Media: Air, water, and other fluids compatible with standard Buna seals. Hot water, steam gasoline, and many oils require special seal materials - Consult representative or factory. (Series 50 pressure ratings may change due to the viscosity of the liquid-consult factory for de-rating)

Valve Temperature Range: STANDARD VALVES – 0°F (-18°C) to 104°F (40°C) ambient; 0°F (-18°C) to 150°F (65°C) media. OPTIONAL VALVES – can tolerate much higher or much lower ambient and media temperatures. Consult factory for specifics.

Maximum Operating Pressure Differentials: See Catalog listings.

Burst Pressure: Series 20, 30, 50 - 5000 PSI Series 70 - 4000 PSI

Leakage: Bubble tight for standard valves

Vacuum: To 5 Microns - Consult factory

ELECTRICAL CHARACTERISTICS

Coil Voltage: Series 20 - 5 to 825 VAC 50-60 HZ. – 1.8 to 265V DC
 Series 30 - 5.2 to 650 VAC 50-60 HZ. – 2 to 240V DC
 Series 50 - 5.4 to 575 VAC 50-60 HZ. – 3.0 to 300V DC
 Series 70 - 12 to 1050 VAC 50-60 HZ. – 2.5 to 220V DC

Nominal Power:

Series	D.C.	A.C.	Series	D.C.	A.C.
20	9.5	8.7 Watts	50	7.0	6.0 Watts
30	8.0	8.0 Watts	70	16.0	18.0 Watts

Coil Construction: Non-molded Class A, Molded and potted Class F. (Class H optional)

Typical Response Time on Air: 4 - 16 Milliseconds—all series

MECHANICAL CHARACTERISTICS

Body: Stainless steel (standard) - Ser. 20, 50, & 70
 Stainless steel (optional) - Ser. 30
 Brass (standard) - Ser. 30
 Brass (optional) - Ser. 20, 50, & 70 - Consult factory
 Aluminum (optional) - Ser. 50 - Consult factory

Orifice Diameter: See catalog listings

Porting: See catalog listings

Housing: Grommet & 1/2" NPT conduit - many options available.

Listings: Most valves are U.L. and CSA listed - Consult factory for specifics.

OPTIONS AVAILABLE: – 2 WAY NORMALLY OPEN FOR ILLUSTRATED OPTIONS SEE PAGES 76-81 FOR FLOW CHARTS SEE PAGES 95-97

HOUSING OPTIONS—see page 78

STRAIN RELIEF CONNECTOR
All Models

SINGLE AUTOMOTIVE
All Models except 51

DOUBLE AUTOMOTIVE
All Models except 51

"AN" CONNECTOR
All Models

SPLICE BOX HOUSING
All Models

JIC HOUSING
Model 21

YOKE
All Models

MOUNTING BRACKET
All Models

COIL OPTIONS—see page 79

MOLDED COIL
All Models

THIRD WIRE GROUND
All conduit Models

POTTED COIL & HOUSING

All Models

SPADE TERMINAL COIL - MOLDED
Models 21, 31, 51

HIGH TEMPERATURE MOLDED COIL
All Models

EUROPEAN DIN STYLE COIL
Models 21, 31

BODY OPTIONS—see page 80

FINE METERING
Model 21

METERING TO 1/2 ORIFICE
Model 21

MANUAL OVERRIDE
21*, 71

METERED EX PORT
Models 21, 31
Consult Factory

PORT OPTIONS—see page 81

BOTTOM CAVITY PORT
All Models

MANIFOLD MOUNT
All Models

FLANGE MOUNT
Models 21, 71

MISCELLANEOUS OPTIONS—see page 76

SILVER SHADING RING
All Models

ALUMINUM SHADING RING
All Models

BUILT IN MUFFLER
All Models

UNIVERSAL MOUNTING BRACKET
Models 21, 31, 51

Note: Availability of certain options or combination of options may vary with quantity of units ordered - Consult representative or factory.

* Not available over 250 psi

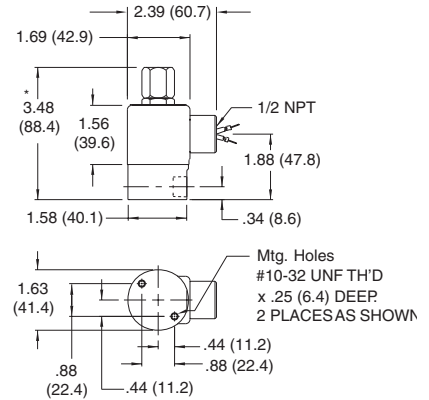

* ADD .165 (4.2) FOR SPADE TERMINAL COIL OPTION

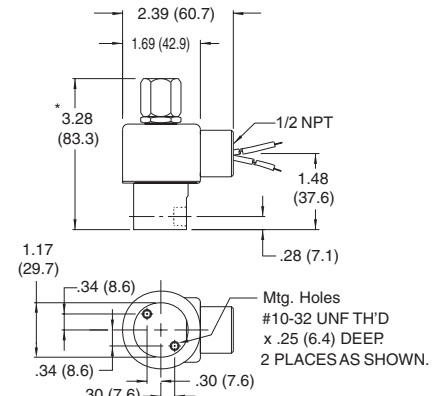

* ADD .100 (2.5) FOR SPADE TERMINAL COIL OPTION

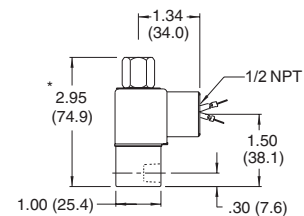

* ADD .232 (5.9) FOR SPADE TERMINAL COIL OPTION

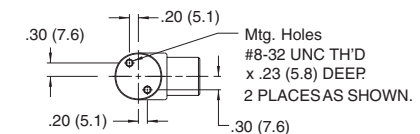

* ADD .232 (5.9) FOR SPADE TERMINAL COIL OPTION

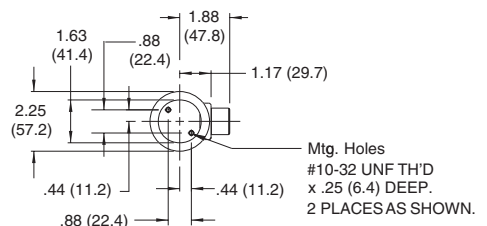
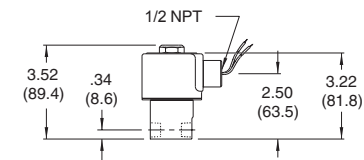

SERIES 20—MODEL 21

+MAX. OPER. PRESS. DIFF.		ORIFICE SIZE INLET EXH.	CV FACTOR INLET EXH.	VALVE NUMBER				REPAIR PACK WT. 0.25
AC	DC			GROMMET HOUSING Grommet Valve WT. 1.13 LB. 1/8 NPT PORTS		CONDUIT HOUSING Conduit Valve WT. 1.19 LB. 1/8 NPT PORTS		
400 (700)	400 (700)	1/32	.024	21G7XGV	21G9ZGV	21G7XCV	21G9ZCV	K21GDX
235 (500)	235 (500)	3/64	.053	21H7XGV	21H9ZGV	21H7XCV	21H9ZCV	K21HDX
150 (350)	150 (350)	1/16	.095	21J7XGV	21J9ZGV	21J7XCV	21J9ZCV	K21JDX
100 (150)	100 (150)	3/32	.156	21K7XGV	21K9ZGV	21K7XCV	21K9ZCV ✓	K21KDX
35 (40)	35 (40)	1/8	.201	*21N7XGV	*21N9ZGV	*21N7XCV	*21N9ZCV	K21NDX



2-WAY NORMALLY OPEN GROMMET



2-WAY NORMALLY OPEN CONDUIT

*VALVES WITH 1/8 SLEEVE ORIFICE ARE UL LISTED ONLY

SERIES 30—MODEL 31

+MAX. OPER. PRESS. DIFF.		ORIFICE SIZE INLET EXH.	CV FACTOR INLET EXH.	VALVE NUMBER				REPAIR PACK WT. 0.25
AC	DC			GROMMET HOUSING Grommet Valve WT. 0.75 LB. 1/8 NPT PORTS		CONDUIT HOUSING Conduit Valve WT. 0.81 LB. 1/8 NPT PORTS		
300	300	1/32	.024	31G5XGV	31G5XCV	31G5XCV	31G5XCV	K31GDX
175	175	3/64	.052	31H5XGV	31H5XCV	31H5XCV	31H5XCV	K31HDX
125	125	1/16	.095	31J5XGV	31J5XCV	31J5XCV	31J5XCV	K31JDX
75	75	3/32	.160	31K5XGV ✓	31K5XCV	31K5XCV	31K5XCV	K31KDX



2-WAY NORMALLY OPEN GROMMET



2-WAY NORMALLY OPEN CONDUIT

SERIES 50—MODEL 51

+MAX. OPER. PRESS. DIFF.		ORIFICE SIZE INLET EXH.	CV FACTOR INLET EXH.	VALVE NUMBER				REPAIR PACK WT. 0.25
AC	DC			GROMMET HOUSING Grommet Valve WT. 0.38 LB. 1/8 NPT PORTS		CONDUIT HOUSING Conduit Valve WT. 0.44 LB. 1/8 NPT PORTS		
400	200	1/32	.020	51G8XGB	51G8XCB	51G8XCB	51G8XCB	K51GDX
200	100	3/64	.048	51H8XGB	51H8XCB	51H8XCB	51H8XCB	K51HDX
125	60	1/16	.075	51J8XGB ✓	51J8XCB	51J8XCB	51J8XCB	K51JDX
40	40	3/32	.150	51K8XGB	51K8XCB	51K8XCB	51K8XCB	K51KDX



2-WAY NORMALLY OPEN GROMMET



2-WAY NORMALLY OPEN CONDUIT

SERIES 70—MODEL 71

+MAX. OPER. PRESS. DIFF.		ORIFICE SIZE INLET EXH.	CV FACTOR INLET EXH.	VALVE NUMBER				REPAIR PACK WT. 0.25
AC	DC			GROMMET HOUSING Grommet Valve WT. 2.00 LB. 1/4 NPT PORTS		CONDUIT HOUSING Conduit Valve WT. 2.06 LB. 1/4 NPT PORTS		
350	350	1/16	.09	71J9ZGV	71J9ZCV	71J9ZCV	71J9ZCV	K71JDX
250	250	3/32	.22	71K9ZGV	71K9ZCV	71K9ZCV	71K9ZCV	K71KDX
175	175	1/8	.35	71N9ZGV	71N9ZCV	71N9ZCV	71N9ZCV	K71NDX
125	125	5/32	.45	71O9ZGV	71O9ZCV	71O9ZCV	71O9ZCV	K71ODX
100	100	3/16	.50	71P9ZGV	71P9ZCV ✓	71P9ZCV	71P9ZCV	K71PDX



2-WAY NORMALLY OPEN GROMMET



2-WAY NORMALLY OPEN CONDUIT

WHEN ORDERING VALVES OR REPAIR PACKS ADD VOLTAGE AND FREQUENCY TO COMPLETE VALVE NUMBER.
EXAMPLES: VALVE (71K9XGV-120/60) REPAIR PACK (K71KDX-AC) See repair pack reference page 82

†Ratings in brackets are optional extended ratings; consult factory

*FKM SEALS NOT RECOMMENDED FOR PRESSURE ABOVE 500 PSI.

NOTE: The above checked (✓) Valves, but with optional molded coils, are most popular based on sales and likely to be in Distributor stock.

SPECIFICATIONS—2-WAY NORMALLY CLOSED

OPERATING CONDITIONS

Media: Air, water, and other fluids compatible with standard Buna seals. Hot water, steam gasoline, and many oils require special seal materials - Consult representative or factory.

Valve Temperature Range: STANDARD VALVES – 0°F (-18°C) to 104°F (40°C) ambient; 0°F (-18°C) to 150°F (65°C) media. OPTIONAL VALVES – can tolerate much higher or much lower ambient and media temperatures. Consult factory for specifics.

Maximum Operating Pressure Differentials: See Catalog listings.

Burst Pressure: Series 20, 30, 50 - 5000 PSI Series 70 - 4000 PSI

Leakage: Bubble tight for standard valves

Vacuum: To 5 Microns - Consult factory

ELECTRICAL CHARACTERISTICS

Coil Voltage: Series 20 - 5 to 825 VAC 50-60 HZ. – 1.8 to 265V DC
 Series 30 - 5.2 to 650 VAC 50-60 HZ. – 2 to 240V DC
 Series 50 - 5.4 to 575 VAC 50-60 HZ. – 3.0 to 300V DC
 Series 70 - 12 to 1050 VAC 50-60 HZ. – 2.5 to 220V DC

Nominal Power:

Series	D.C.	A.C.	Series	D.C.	A.C.
20	9.5	7.7 Watts	50	7.0	6.0 Watts
30	8.0	7.0 Watts	70	16.0	18.0 Watts

Coil Construction: Non-molded Class A, Molded and potted Class F. (Class H optional)

Typical Response Time on Air: 4 - 16 Milliseconds—all series

MECHANICAL CHARACTERISTICS

Body: Stainless steel (standard) - Ser. 20, 50, & 70
 Brass (optional) - Ser. 20, 50, & 70 - Consult factory
 Brass (standard) - Ser. 30
 Aluminum (optional) - Ser. 50 - Consult factory

Orifice Diameter: See catalog listings

Porting: See catalog listings

Housing: Grommet & 1/2" NPT conduit - many options available.

Listings: Most valves are U.L. and CSA listed - Consult factory for specifics.

OPTIONS AVAILABLE: – 2 WAY NORMALLY CLOSED

FOR ILLUSTRATED OPTIONS SEE PAGES 76-81

FOR FLOW CHARTS SEE PAGES 95-97

HOUSING OPTIONS—see page 78

STRAIN RELIEF CONNECTOR
All Models

SINGLE AUTOMOTIVE
All Models except 52

DOUBLE AUTOMOTIVE
All Models except 52

"AN" CONNECTOR
All Models

SPLICE BOX HOUSING
All Models

JIC HOUSING
Model 22

YOKE
All Models

MOUNTING BRACKET
All Models

COIL OPTIONS—see page 79

MOLDED COIL
All Models

THIRD WIRE GROUND
All conduit Models

POTTED COIL & HOUSING
All Models

SPADE TERMINAL COIL - MOLDED
Models 22, 32, 52

HIGH TEMPERATURE MOLDED COIL
All Models

EUROPEAN DIN STYLE COIL
Model 22, 32

BODY OPTIONS—see page 80

METERING TO 1/8 ORIFICE
Model 22, 32, 52

METERING TO 1/4 ORIFICE
Model 22, 72

METERED BYPASS
Model 22

MANUAL OVERRIDE
Model 22*, 72**†

PORT OPTIONS—see page 81

BOTTOM ORIFICE PORT
All Models

BOTTOM CAVITY PORT
Model 22**, 32, 52, 72

PORT 90° LEFT
Model 22, 32, 72

MANIFOLD MOUNT
Model 22**, 32, 52, 72

FLANGE MOUNT
Models 22**, 72

PORT 90° RIGHT
Model 22, 32, 72

MISCELLANEOUS OPTIONS—see page 76

SILVER SHADING RING
All Models

ALUMINUM SHADING RING
All Models

BUILT IN MUFFLER
All Models

UNIVERSAL MOUNTING BRACKET
Models 22, 32, 52, 72

Note: Availability of certain options or combination of options may vary with quantity of units ordered - Consult representative or factory.

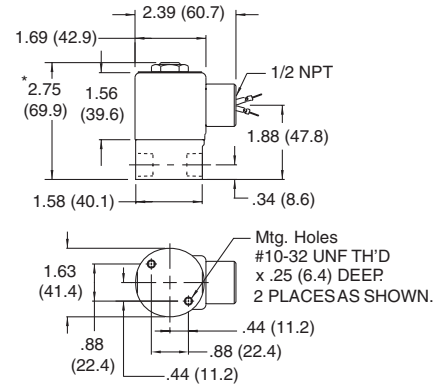

* ADD .165 (4.2) FOR SPADE TERMINAL COIL OPTION

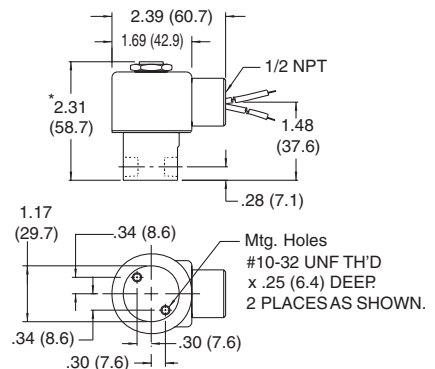

* ADD .100 (2.5) FOR SPADE TERMINAL COIL OPTION

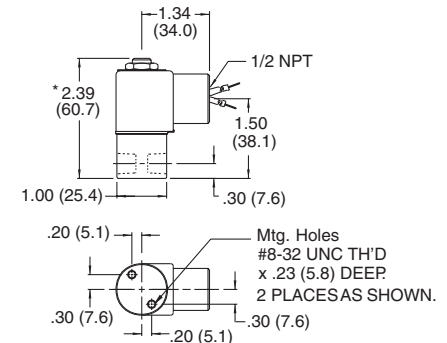

* ADD .232 (5.9) FOR SPADE TERMINAL COIL OPTION

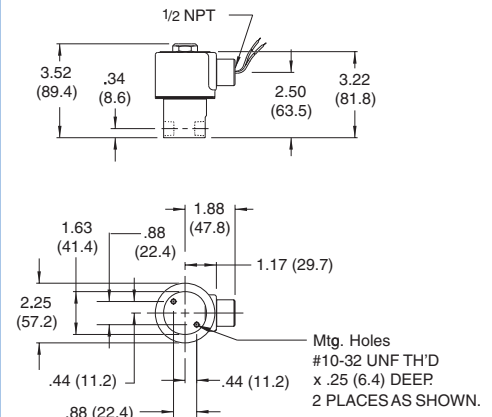

* Not available over 250 psi

** Not available in 1/4" orifice & larger

† Not available over 300 psi

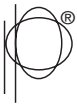

PETER PAUL

SOLENOID VALVES . . .

SERIES 20—MODEL 22

+MAX. OPER. PRESS. DIFF.		ORIFICE SIZE INLET EXH.	CV FACTOR INLET EXH.
AC	DC		
500	500	1/32	.024
250 (500)	250 (500)	3/64	.052
200 (400)	200 (400)	1/16	.095
125 (300)	125 (250)	3/32	.156
100 (200)	100 (200)	1/8	.284
75	50	5/32	.404
50	25	3/16	.500
20	5	1/4	.700
15	—	5/16	1.000

VALVE NUMBER

GROMMET HOUSING		CONDUIT HOUSING		REPAIR PACK WT. 0.25 LB
Grommet Valve WT. 1.06 LB.		Conduit Valve WT. 1.13 LB		
1/2 NPT PORTS	1/4 NPT PORTS	1/2 NPT PORTS	1/4 NPT PORTS	
22G7DGV	22G9DGV	22G7DCV	22G9DCV	K22GDD
22H7DGV	22H9DGV	22H7DCV	22H9DCV	K22HDD
22J7DGV	22J9DGV	22J7DCV	22J9DCV	K22JDD
22K7DGV	22K9DGV	22K7DCV	22K9DCV	K22KDD
22N7DGV	22N9DGV	22N7DCV	22N9DCV ✓	K22NDD
22O7DGV	22O9DGV	22O7DCV	22O9DCV	K22ODD
22P7DGV	22P9DGV	22P7DCV	22P9DCV	K22PDD
22R7DGV	22R9DGV	22R7DCV	22R9DCV	K22RDD
—	22S9DGV	—	22S9DCV	K22SDD

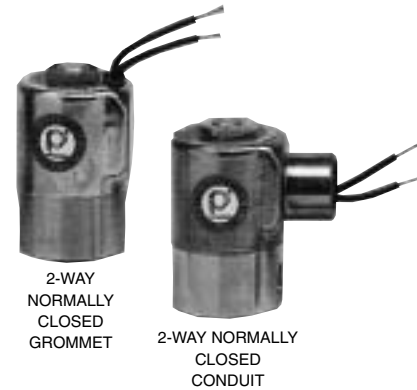

SERIES 30—MODEL 32

MAX. OPER. PRESS. DIFF.		ORIFICE SIZE INLET EXH.	CV FACTOR INLET EXH.
AC	DC		
*375 (650)	*375 (650)	1/32	.024
*280 (650)	*280 (650)	3/64	.055
275	250	1/16	.105
180	100	3/32	.195
130	80	7/64	.220
90	50	1/8	.275
60	25	5/32	.360
40	15	3/16	.400

VALVE NUMBER

GROMMET HOUSING		CONDUIT HOUSING		REPAIR PACK WT. 0.25 LB
Grommet Valve WT. 0.75 LB.		Conduit Valve WT. 0.75 LB		
1/2 NPT PORTS	1/4 NPT PORTS	1/2 NPT PORTS	1/4 NPT PORTS	
BRASS	STAINLESS	BRASS STEEL	STAINLESS STEEL	
32G5DGV	—	32G5DCV	—	K32GDD
32H5DGV	32H8DGV	32H5DCV	32H8DCV	K32HDD
32J5DGV	32J8DGV	32J5DCV	32J8DCV	K32JDD
32K5DGV	32K8DGV	32K5DCV	32K8DCV	K32KDD
32L5DGV	32L8DGV	32L5DCV	32L8DCV	K32LDD
32N5DGV ✓	32N8DGV	32N5DCV	32N8DCV	K32NDD
32O5DGV	32O8DGV	32O5DCV	32O8DCV	K32ODD
32P5DGV	32P8DGV	32P5DCV	32P8DCV	K32PDD

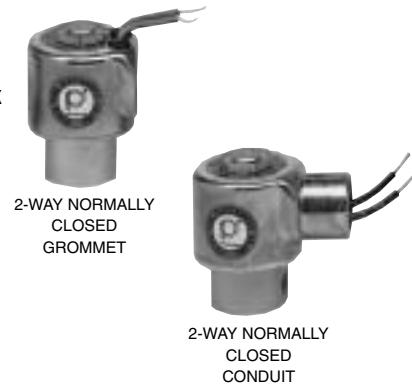

SERIES 50—MODEL 52

+MAX. OPER. PRESS. DIFF.		ORIFICE SIZE INLET EXH.	CV FACTOR INLET EXH.
AC	DC		
*500 (1000)	*250 (1000)	1/32	.022
*400 (700)	150 (450)	3/64	.055
200 (470)	100 (325)	1/16	.075
150 (270)	75 (210)	5/64	.134
100 (260)	45 (175)	3/32	.156
75 (135)	25 (100)	1/8	.230
40 (50)	10 (20)	5/32	.292

VALVE NUMBER

GROMMET HOUSING		CONDUIT HOUSING		REPAIR PACK WT. 0.19 LB
Grommet Valve WT. 0.38 LB.		Conduit Valve WT. 0.44 LB		
1/2 NPT PORTS	1/4 NPT PORTS	1/2 NPT PORTS	1/4 NPT PORTS	
52G8DGB	—	52G8DCB	—	K52GDD
52H8DGB	—	52H8DCB	—	K52HDD
52J8DGB ✓	—	52J8DCB	—	K52JDD
52V8DGB	—	52V8DCB	—	K52VDD
52K8DGB	—	52K8DCB	—	K52KDD
52N8DGB	—	52N8DCB	—	K52NDD
52O8DGB	—	52O8DCB	—	K52ODD

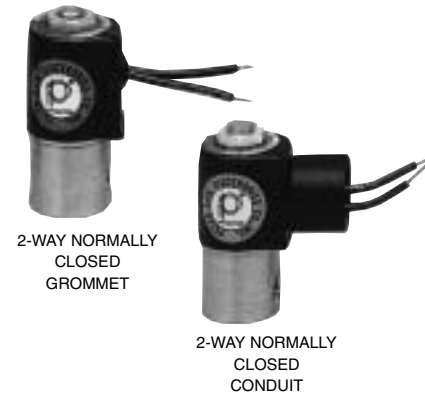

SERIES 70—MODEL 72

MAX. OPER. PRESS. DIFF.		ORIFICE SIZE INLET EXH.	CV FACTOR INLET EXH.
AC	DC		
500	500	3/32	.22
300	300	1/8	.35
225	225	5/32	.45
140	140	3/16	.55
100	100	1/4	.78

VALVE NUMBER

GROMMET HOUSING		CONDUIT HOUSING		REPAIR PACK WT. 0.38 LB
Grommet Valve WT. 2.00 LB.		Conduit Valve WT. 2.06LB		
1/2 NPT PORTS	1/4 NPT PORTS	1/2 NPT PORTS	1/4 NPT PORTS	
72K9DGV	—	72K9DCV	—	K72KDD
72N9DGV	—	72N9DCV	—	K72NDD
72O9DGV	—	72O9DCV	—	K72ODD
72P9DGV	—	72P9DCV	—	K72PDD
72R9DGV ✓	—	72R9DCV	—	K72RDD



WHEN ORDERING VALVES OR REPAIR PACKS ADD VOLTAGE AND FREQUENCY TO COMPLETE VALVE NUMBER.
 EXAMPLES: VALVE (72K9DGV-120/60) REPAIR PACK (K72KDD-AC) See repair pack reference page 82

*FKM seals not recommended for pressure ratings above 500 PSI

NOTE: The above checked (✓) Valves, but with optional molded coils, are most popular based on sales and likely to be in Distributor stock.

3-WAY NORMALLY CLOSED Exhaust to atmosphere

SPECIFICATIONS—3-WAY NORMALLY CLOSED

OPERATING CONDITIONS

Media: Air, water, and other fluids compatible with standard Buna seals. Hot water, steam gasoline, and many oils require special seal materials - Consult representative or factory.

Valve Temperature Range: STANDARD VALVES – 0°F (-18°C) to 104°F (40°C) ambient; 0°F (-18°C) to 150°F (65°C) media. OPTIONAL VALVES – can tolerate much higher or much lower ambient and media temperatures. Consult factory for specifics.

Maximum Operating Pressure Differentials: See Catalog listings.

Burst Pressure: Series 20, 30, 50 - 5000 PSI Series 70 - 4000 PSI

Leakage: Bubble tight for standard valves

Vacuum: To 5 Microns - Consult factory

ELECTRICAL CHARACTERISTICS

Coil Voltage: Series 20 - 5 to 825 VAC 50-60 HZ. – 1.8 to 265V DC
Series 30 - 5.2 to 650 VAC 50-60 HZ. – 2 to 240V DC
Series 50 - 5.4 to 575 VAC 50-60 HZ. – 3.0 to 300V DC
Series 70 - 12 to 1050 VAC 50-60 HZ. – 2.5 to 220V DC

Nominal Power:

Series	D.C.	A.C.	Series	D.C.	A.C.
20	9.5	8.7 Watts	50	7.0	6.0 Watts
30	8.0	8.0 Watts	70	16.0	18.0 Watts

Coil Construction: Non-molded Class A, Molded and potted Class F. (Class H optional)

Typical Response Time on Air: 4 - 16 Milliseconds—all series

MECHANICAL CHARACTERISTICS

Body: Stainless steel (standard) - Ser. 20, 50, & 70
Brass (standard) - Ser. 30
Brass (optional) - Ser. 20, 50, & 70 - Consult factory
Aluminum (optional) - Ser. 50 - Consult factory

Orifice Diameter: See catalog listings

Porting: See catalog listings

Housing: Grommet & 1/2" NPT conduit - many options available.

Listings: Most valves are U.L. and CSA listed - Consult factory for specifics.

OPTIONS AVAILABLE: –

3 WAY NORMALLY CLOSED EXHAUST TO ATMOSPHERE

FOR ILLUSTRATED OPTIONS SEE PAGES 76-81

FOR FLOW CHARTS SEE PAGES 95-97

HOUSING OPTIONS—see page 78

STRAIN RELIEF CONNECTOR
All Models

SINGLE AUTOMOTIVE
All Models except 53

DOUBLE AUTOMOTIVE
All Models except 53

"AN" CONNECTOR
All Models

SPLICE BOX HOUSING
All Models

JIC HOUSING
Model 23

YOKE
All Models

MOUNTING BRACKET
All Models

COIL OPTIONS—see page 79

MOLDED COIL
All Models

POTTED COIL & HOUSING
All Models

THIRD WIRE GROUND
All conduit Models

SPADE TERMINAL COIL - MOLDED
Models 23, 33, 53

HIGH TEMPERATURE MOLDED COIL
All Models

EUROPEAN DIN STYLE
Models 23, 33

BODY OPTIONS—see page 80

METERING TO 1/8 ORIFICE
Model 23, 33, 53

METERING TO 1/4 ORIFICE
Model 23, 73

METERED BYPASS
Model 23

MANUAL OVERRIDE
Model 23*, 73**

METERED EXH. PORT
Model 23, 33

PORT OPTIONS—see page 81

BOTTOM ORIFICE PORT
All Models

BOTTOM CAVITY PORT
Model 23**, 33, 53, 73

PORT 90° LEFT
All Models except 53

MANIFOLD MOUNT
Model 23**, 33, 53, 73

FLANGE MOUNT
Models 23**, 73

PORT 90° RIGHT
All Models except 53

MISCELLANEOUS OPTIONS—see page 76

SILVER SHADING RING
All Models

ALUMINUM SHADING RING
All Models

BUILT IN MUFFLER
All Models

UNIVERSAL MOUNTING BRACKET
Models 23, 33, 53

* Not available over 250 psi

** Not available in 1/4" orifice

Note: Availability of certain options or combination of options may vary with quantity of units ordered - Consult representative or factory.

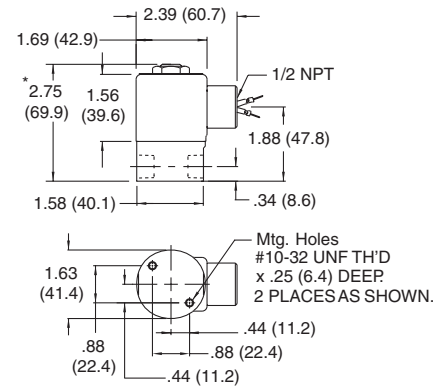

* ADD .165 (4.2) FOR SPADE TERMINAL COIL OPTION

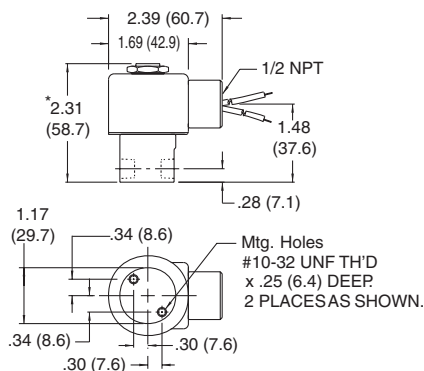

* ADD .100 (2.5) FOR SPADE TERMINAL COIL OPTION

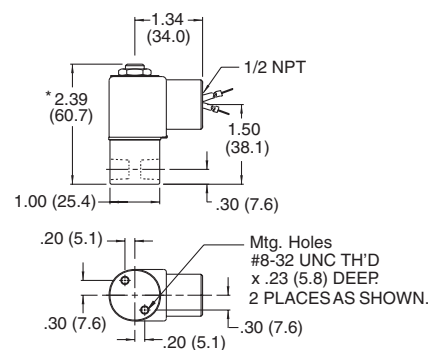

* ADD .232 (5.9) FOR SPADE TERMINAL COIL OPTION

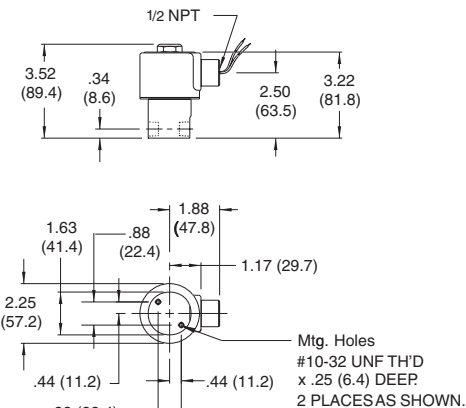

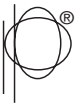

**PETER
PAUL**

SOLENOID VALVES . . .

SERIES 20—MODEL 23

+MAX. OPER. PRESS. DIFF.		ORIFICE SIZE		CV FACTOR		VALVE NUMBER		REPAIR PACK WT. 0.25
AC	DC	INLET	EXH.	INLET	EXH.	GROMMET HOUSING Grommet Valve WT. 1.06 LB. 1/2 NPT PORTS	CONDUIT HOUSING Conduit Valve WT. 1.13 LB 1/2 NPT PORTS	
400	400	1/32	1/32	.024	.024	23GG7DGV	23GG9DGV	K23GGD
150 (200)	150 (200)	3/64	1/16	.052	.095	23HJ7DGV	23HJ9DGV	K23HJD
100 (135)	100 (135)	1/16	1/16	.095	.095	23JJ7DGV	23JJ9DGV	K23JJJ
100 (135)	100 (135)	1/16	3/32	.095	.156	23JK7DGV	23JK9DGV ✓	K23JKD
75 (100)	75 (100)	3/32	3/32	.156	.156	23KK7DGV	23KK9DGV	K23KKD
50 (70)	50 (70)	1/8	3/32	.284	.156	23NK7DGV	23NK9DGV	K23NKD
35 (40)	35 (40)	1/8	1/8	.284	.201	°23NN7DGV	°23NN9DGV	°K23NND
20	20	3/16	3/32	.500	.156	23PK7DGV	23PK9DGV	K23PKD
20	20	3/16	1/8	.500	.201	°23PN7DGV	°23PN9DGV	°K23PND
15	—	1/4	3/32	.700	.156	23RK7DGV	23RK9DGV	K23RKD
15	—	1/4	1/8	.700	.201	°23RN7DGV	°23RN9DGV	°K23RND



3-WAY NORMALLY
CLOSED CONDUIT



3-WAY NORMALLY
CLOSED GROMMET

°VALVES WITH 1/8 SLEEVE ORIFICE ARE UL LISTED ONLY

SERIES 30—MODEL 33

+MAX. OPER. PRESS. DIFF.		ORIFICE SIZE		CV FACTOR		VALVE NUMBER		REPAIR PACK WT. 0.25
AC	DC	INLET	EXH.	INLET	EXH.	GROMMET HOUSING Grommet Valve WT. 0.75 LB. 1/2 NPT PORTS*	CONDUIT HOUSING Conduit Valve WT. 0.81 LB 1/2 NPT PORTS*	
300	300	1/32	1/32	.024	.024	33GG5DGV	33GG5DCV	K33GGD
175	175	3/64	1/16	.052	.095	33HJ5DGV	33HJ5DCV	K33HJD
125	125	1/16	1/16	.095	.095	33JJ5DGV	33JJ5DCV ✓	K33JJJ
75	75	3/32	3/32	.160	.160	33KK5DGV	33KK5DCV	K33KKD
50	50	1/8	3/32	.275	.160	33NK5DGV	33NK5DCV	K33NKD



3-WAY NORMALLY
CLOSED CONDUIT



3-WAY NORMALLY
CLOSED GROMMET

SERIES 50—MODEL 53

+MAX. OPER. PRESS. DIFF.		ORIFICE SIZE		CV FACTOR		VALVE NUMBER		REPAIR PACK WT. 0.25
AC	DC	INLET	EXH.	INLET	EXH.	GROMMET HOUSING Grommet Valve WT. 0.38 LB. 1/2 NPT PORTS*	CONDUIT HOUSING Conduit Valve WT. 0.44 LB 1/2 NPT PORTS*	
200	200	1/32	1/32	.022	.020	53GG8DGB	53GG8DCB	K53GGD
150	150	3/64	3/64	.055	.048	53HH8DGB	53HH8DCB	K53HHD
150	150	3/64	1/16	.055	.075	53HJ8DGB	53HJ8DCB	K53HJD
100	100	1/16	1/16	.075	.075	53JJ8DGB ✓	53JJ8DCB	K53JJJ
60	60	3/32	1/16	.156	.075	53KJ8DGB	53KJ8DCB	K53KJD
50	50	3/32	3/32	.156	.150	53KK8DGB	53KK8DCB	K53KKD
30	30	1/8	1/16	.230	.075	53NJ8DGB	53NJ8DCB	K53NJD
30	30	1/8	3/32	.230	.150	53NK8DGB	53NK8DCB	K53NKD



3-WAY NORMALLY
CLOSED CONDUIT



3-WAY NORMALLY
CLOSED GROMMET

SERIES 70—MODEL 73

+MAX. OPER. PRESS. DIFF.		ORIFICE SIZE		CV FACTOR		VALVE NUMBER		REPAIR PACK WT. 0.25
AC	DC	INLET	EXH.	INLET	EXH.	GROMMET HOUSING Grommet Valve WT. 2.00 LB. 1/2 NPT PORTS*	CONDUIT HOUSING Conduit Valve WT. 2.06 LB 1/2 NPT PORTS*	
350	350	1/16	1/16	.09	.09	73JJ9DGV	73JJ9DCV	K73JJJ
250	250	3/32	3/32	.22	.22	73KK9DGV	73KK9DCV	K73KKD
175	175	1/8	1/8	.35	.35	73NN9DGV	73NN9DCV	K73NND
125	125	5/32	5/32	.45	.45	73009DGV ✓	73009DCV	K7300D
100	100	3/16	3/16	.50	.50	73PP9DGV	73PP9DCV	K73PPD
50	50	1/4	3/16	.78	.50	73RP9DGV	73RP9DCV	K73RPD



3-WAY NORMALLY
CLOSED CONDUIT



3-WAY NORMALLY
CLOSED GROMMET

WHEN ORDERING VALVES OR REPAIR PACKS ADD VOLTAGE AND FREQUENCY TO COMPLETE VALVE NUMBER.

EXAMPLES: VALVE (73KK9DGV-120/60) REPAIR PACK (K73KKD-AC) See repair pack reference page 82

†Ratings in brackets are optional extended ratings; consult factory

NOTE: The above checked (✓) Valves, but with optional molded coils, are most popular based on sales and likely to be in Distributor stock.

3-WAY NORMALLY CLOSED Piped Exhaust

SPECIFICATIONS—3-WAY NORMALLY CLOSED

OPERATING CONDITIONS

Media: Air, water, and other fluids compatible with standard Buna seals. Hot water, steam gasoline, and many oils require special seal materials - Consult representative or factory. (Series 50 pressure ratings may change due to the viscosity of the liquid-consult factory for de-rating)

Valve Temperature Range: STANDARD VALVES – 0°F (-18°C) to 104°F (40°C) ambient; 0°F (-18°C) to 150°F (65°C) media. OPTIONAL VALVES – can tolerate much higher or much lower ambient and media temperatures. Consult factory for specifics.

Maximum Operating Pressure Differentials: See Catalog listings.

Burst Pressure: Series 20, 30, 50 - 5000 PSI Series 70 - 4000 PSI

Leakage: Bubble tight for standard valves

Vacuum: To 5 Microns - Consult factory

ELECTRICAL CHARACTERISTICS

Coil Voltage: Series 20 - 5 to 825 VAC 50-60 HZ. – 1.8 to 265V DC
Series 30 - 5.2 to 650 VAC 50-60 HZ. – 2 to 240V DC
Series 50 - 5.4 to 575 VAC 50-60 HZ. – 3.0 to 300V DC
Series 70 - 12 to 1050 VAC 50-60 HZ. – 2.5 to 220V DC

Nominal Power:

Series	D.C.	A.C.	Series	D.C.	A.C.
20	9.5	8.7 Watts	50	7.0	6.0 Watts
30	8.0	8.0 Watts	70	16.0	18.0 Watts

Coil Construction: Non-molded Class A, Molded and potted Class F. (Class H optional)

Typical Response Time on Air: 4 - 16 Milliseconds—all series

MECHANICAL CHARACTERISTICS

Body: Stainless steel (standard) - Ser. 20, 50, & 70
Brass (standard) - Ser. 30
Brass (optional) - Ser. 20, 50, & 70 - Consult factory
Aluminum (optional) - Ser. 50 & 70 - Consult factory

Orifice Diameter: See catalog listings

Porting: See catalog listings

Housing: Grommet & 1/2" NPT conduit - many options available.

Listings: Most valves are U.L. and CSA listed - Consult factory for specifics.

DE-ENERGIZED

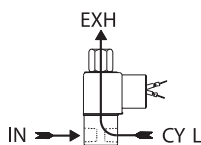

ENERGIZED

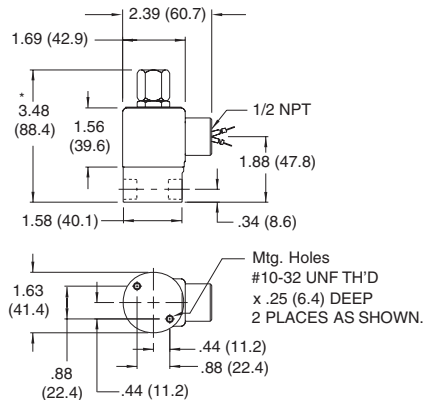
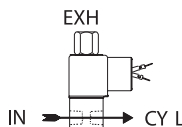

*ADD .165 (4.2) FOR SPADE TERMINAL COIL OPTION

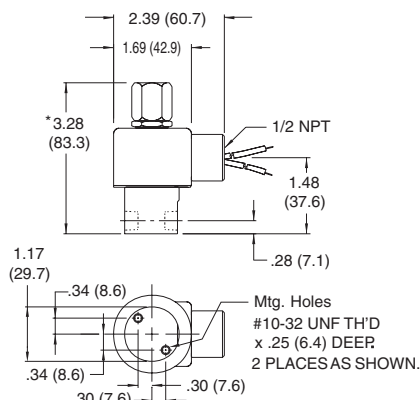

*ADD .100 (2.5) FOR SPADE TERMINAL COIL OPTION

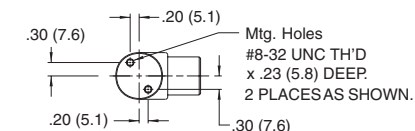
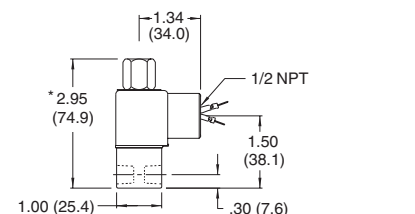

*ADD .232 (5.9) FOR SPADE TERMINAL COIL OPTION

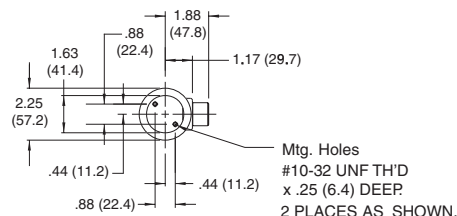
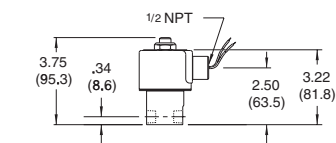

OPTIONS AVAILABLE: –

3 WAY NORMALLY CLOSED PIPED EXHAUST FOR ILLUSTRATED OPTIONS SEE PAGES 76-81 FOR FLOW CHARTS SEE PAGES 95-97

HOUSING OPTIONS—see page 78

STRAIN RELIEF CONNECTOR

All Models

SINGLE AUTOMOTIVE

All Models except 53

DOUBLE AUTOMOTIVE

All Models except 53

"AN" CONNECTOR

All Models

SPLICE BOX HOUSING

All Models

JIC HOUSING

Model 23

YOKE

All Models

MOUNTING BRACKET

All Models

COIL OPTIONS—see page 79

MOLDED COIL

All Models

POTTED COIL & HOUSING

All Models

THIRD WIRE GROUND

All conduit Models

SPADE TERMINAL COIL - MOLDED

Models 23, 33, 53

HIGH TEMPERATURE MOLDED COIL

All Models

EUROPEAN KIN STYLE COIL

Models 23, 33

BODY OPTIONS—see page 80

METERING TO 1/8 ORIFICE

Model 23, 33, 53

METERING TO 1/4 ORIFICE

Model 23, 73

METERED BYPASS

Consult Factory
Model 23

MANUAL OVERRIDE

Model 23*, 73**

METERED EXH. PORT

Model 23, 33

PORT OPTIONS—see page 81

BOTTOM ORIFICE PORT

All Models

BOTTOM CAVITY PORT

Model 23, 33, 53, 73**

PORT 90° LEFT

All Models except 53

MANIFOLD MOUNT

Model 23**, 33, 53, 73

FLANGE MOUNT

Models 23**, 73

PORT 90° RIGHT

All Models except 53

MISCELLANEOUS OPTIONS—see page 76

SILVER SHADING RING

All Models

ALUMINUM SHADING RING

All Models

BUILT IN MUFFLER

All Models

UNIVERSAL MOUNTING BRACKET

Models 23, 33, 53

Note: Availability of certain options or combination of options may vary with quantity of units ordered - Consult representative or factory.

* Not available over 250 psi

** Not available in 1/4" orifice



**PETER
PAUL**

SOLENOID VALVES . . .

SERIES 20—MODEL 23

+MAX. OPER. PRESS. DIFF.		ORIFICE SIZE		CV FACTOR		GROMMET HOUSING		CONDUIT HOUSING		REPAIR PACK WT. 0.25
AC	DC	INLET	EXH.	INLET	EXH.	1/8 NPT PORTS	1/4 NPT PORTS	1/8 NPT PORTS	1/4 NPT PORTS	
400	400	1/32	1/32	.024	.024	23GG7XGV	23GG9ZGV	23GG7XCV	23GG9ZCV	K23GGX
150 (200)	150 (200)	3/64	1/16	.052	.095	23HJ7XGV	23HJ9ZGV	23HJ7XCV	23HJ9ZCV	K23HJX
100 (135)	100 (135)	1/16	1/16	.095	.095	23JJ7XGV	23JJ9ZGV	23JJ7XCV	23JJ9ZCV	K23JJX
100 (135)	100 (135)	1/16	3/32	.095	.156	23JK7XGV	23JK9ZGV ✓	23JK7XCV	23JK9ZCV	K23JKX
75 (100)	75 (100)	3/32	3/32	.156	.156	23KK7XGV	23KK9ZGV	23KK7XCV	23KK9ZCV	K23KKX
50 (70)	50 (70)	1/8	3/32	.284	.156	23NK7XGV	23NK9ZGV	23NK7XCV	23NK9ZCV	K23NKX
35 (40)	35 (40)	1/8	1/8	.284	.201	*23NN7XGV	*23NN9ZGV	*23NN7XCV	*23NN9ZCV	K23NNX
20	20	3/16	3/32	.500	.156	23PK7XGV	23PK9ZGV	23PK7XCV	23PK9ZCV	K23PKX
20	20	3/16	1/8	.500	.201	*23PN7XGV	*23PN9ZGV	*23PN7XCV	*23PN9ZCV	K23PNX
15	-	1/4	3/32	.700	.156	23RK7XGV	23RK9ZGV	23RK7XCV	23RK9ZCV	K23RKX
15	-	1/4	1/8	.700	.201	*23RN7XGV	*23RN9ZGV	*23RN7XCV	*23RN9ZCV	K23RNX

*VALVES WITH 1/8 SLEEVE ORIFICE ARE UL LISTED ONLY



3-WAY NORMALLY
CLOSED GROMMET



3-WAY NORMALLY
CLOSED CONDUIT

SERIES 30—MODEL 33

+MAX. OPER. PRESS. DIFF.		ORIFICE SIZE		CV FACTOR		GROMMET HOUSING		CONDUIT HOUSING		REPAIR PACK WT. 0.25
AC	DC	INLET	EXH.	INLET	EXH.	1/8 NPT PORTS	1/4 NPT PORTS	1/8 NPT PORTS	1/4 NPT PORTS	
300	300	1/32	1/32	.024	.024	33GG5XGV		33GG5XCV		K33GGX
175	175	3/64	1/16	.052	.095	33HJ5XGV		33HJ5XCV		K33HJX
125	125	1/16	1/16	.095	.095	33JJ5XGV		33JJ5XCV ✓		K33JJX
75	75	3/32	3/32	.160	.160	33KK5XGV		33KK5XCV		K33KKX
50	50	1/8	3/32	.275	.160	33NK5XGV		33NK5XCV		K33NKX



3-WAY NORMALLY
CLOSED GROMMET

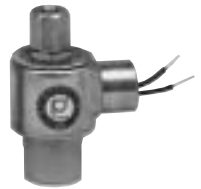

3-WAY NORMALLY
CLOSED CONDUIT

SERIES 50—MODEL 53

+MAX. OPER. PRESS. DIFF.		ORIFICE SIZE		CV FACTOR		GROMMET HOUSING		CONDUIT HOUSING		REPAIR PACK WT. 0.25
AC	DC	INLET	EXH.	INLET	EXH.	1/8 NPT PORTS	1/4 NPT PORTS	1/8 NPT PORTS	1/4 NPT PORTS	
200	200	1/32	1/32	.022	.020	53GG8XGB		53GG8XCB		K53GGX
150	150	3/64	3/64	.055	.048	53HH8XGB		53HH8XCB		K53HHX
150	150	3/64	1/16	.055	.075	53HJ8XGB		53HJ8XCB		K53HJX
100	100	1/16	1/16	.075	.075	53JJ8XGB ✓		53JJ8XCB		K53JJX
60	60	3/32	1/16	.156	.075	53KJ8XGB		53KJ8XCB		K53KJX
50	50	3/32	3/32	.156	.150	53KK8XGB		53KK8XCB		K53KKX
30	30	1/8	1/16	.230	.075	53NJ8XGB		53NJ8XCB		K53NJX
30	30	1/8	3/32	.230	.150	53NK8XGB		53NK8XCB		K53NKX



3-WAY NORMALLY
CLOSED GROMMET



3-WAY NORMALLY
CLOSED CONDUIT

SERIES 70—MODEL 73

+MAX. OPER. PRESS. DIFF.		ORIFICE SIZE		CV FACTOR		GROMMET HOUSING		CONDUIT HOUSING		REPAIR PACK WT. 0.25
AC	DC	INLET	EXH.	INLET	EXH.	1/4 NPT PORTS	1/2 NPT PORTS	1/4 NPT PORTS	1/2 NPT PORTS	
350	350	1/16	1/16	.09	.09	73JJ9ZGV		73JJ9ZCV		K73JJX
250	250	3/32	3/32	.22	.22	73KK9ZGV		73KK9ZCV		K73KKX
175	175	1/8	1/8	.35	.35	73NN9ZGV		73NN9ZCV		K73NNX
125	125	5/32	5/32	.45	.45	73OO9ZGV ✓		73OO9ZCV		K73OOX
100	100	3/16	3/16	.50	.50	73PP9ZGV		73PP9ZCV		K73PPX
50	50	1/4	3/16	.78	.50	73RP9ZGV		73RP9ZCV		K73RPX



3-WAY NORMALLY
CLOSED GROMMET



3-WAY NORMALLY
CLOSED CONDUIT

WHEN ORDERING VALVES OR REPAIR PACKS ADD VOLTAGE AND FREQUENCY TO COMPLETE VALVE NUMBER.
EXAMPLES: VALVE (73KK9ZGV-120/60) REPAIR PACK (K73KKX-AC) See repair pack reference page 82

†Ratings in brackets are optional extended ratings; consult factory

NOTE: The above checked (✓) Valves, but with optional molded coils, are most popular based on sales and likely to be in Distributor stock.

SPECIFICATIONS—3-WAY NORMALLY OPEN

OPERATING CONDITIONS

Media: Air, water, and other fluids compatible with standard Buna seals. Hot water, steam gasoline, and many oils require special seal materials - Consult representative or factory. (Series 50 pressure ratings may change due to the viscosity of the liquid-consult factory for de-rating)

Valve Temperature Range: STANDARD VALVES – 0°F (-18°C) to 104°F (40°C) ambient; 0°F (-18°C) to 150°F (65°C) media. OPTIONAL VALVES – can tolerate much higher or much lower ambient and media

temperatures. Consult factory for specifics.

Maximum Operating Pressure Differentials: See Catalog listings.

Burst Pressure: Series 20, 30, 50 - 5000 PSI Series 70 - 4000 PSI

Leakage: Bubble tight for standard valves

Vacuum: To 5 Microns - Consult factory

ELECTRICAL CHARACTERISTICS

Coil Voltage: Series 20 - 5 to 825 VAC 50-60 HZ. – 1.8 to 265V DC
 Series 30 - 5.2 to 650 VAC 50-60 HZ. – 2 to 240V DC
 Series 50 - 5.4 to 575 VAC 50-60 HZ. – 3.0 to 300V DC
 Series 70 - 12 to 1050 VAC 50-60 HZ. – 2.5 to

220V DC

Nominal Power:

Series	D.C.	A.C.	Series	D.C.	A.C.
20	9.5	8.7 Watts	50	7.0	6.0 Watts
30	8.0	8.0 Watts	70	16.0	18.0 Watts

Coil Construction: Non-molded Class A, Molded and potted Class F. (Class H optional)

Typical Response Time on Air: 4 - 16 Milliseconds—all series

MECHANICAL CHARACTERISTICS

Body: Stainless steel (standard) - Ser. 20, 50, & 70
 Brass (standard) - Ser. 30
 Brass (optional) - Ser. 20, 50, & 70 - Consult factory
 Aluminum (optional) - Ser. 50 & 70 - Consult factory

Orifice Diameter: See catalog listings

Porting: See catalog listings

Housing: Grommet & 1/2" NPT conduit - many options available.

Listings: Most valves are U.L. and CSA listed - Consult factory for specifics.

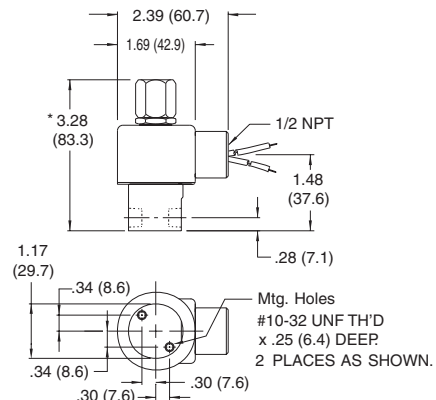
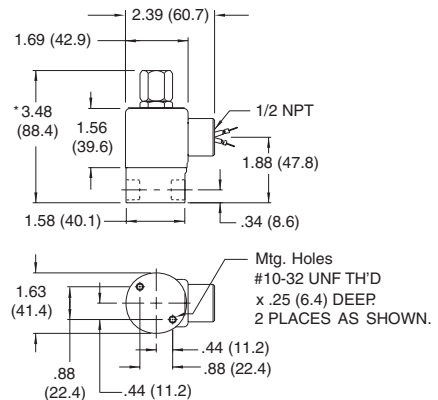
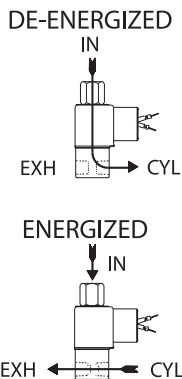

*ADD .100 (2.5) FOR SPADE TERMINAL COIL OPTION

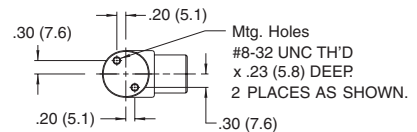
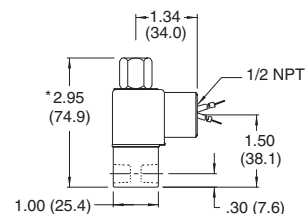

*ADD .232 (5.9) FOR SPADE TERMINAL COIL OPTION

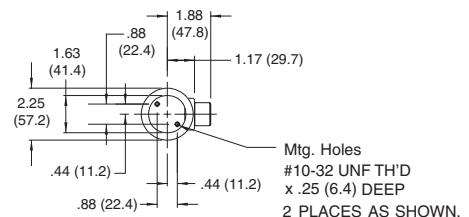
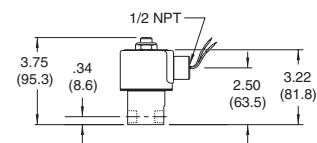

OPTIONS AVAILABLE: – 3 WAY NORMALLY OPEN

FOR ILLUSTRATED OPTIONS SEE PAGES 76-81

FOR FLOW CHARTS SEE PAGES 95-97

HOUSING OPTIONS—see page 78

STRAIN RELIEF CONNECTOR
 All Models

SINGLE AUTOMOTIVE
 All Models except 54

DOUBLE AUTOMOTIVE
 All Models except 54

"AN" CONNECTOR
 All Models

SPLICE BOX HOUSING
 All Models

JIC HOUSING
 Model 24

YOKE
 All Models

MOUNTING BRACKET
 All Models

* Not available over 250 psi

COIL OPTIONS—see page 79

MOLDED COIL
 All Models

THIRD WIRE GROUND
 All conduit Models
POTTED COIL & HOUSING
 All Models

SPADE TERMINAL COIL - MOLDED
 Models 24, 34, 54

HIGH TEMPERATURE MOLDED COIL
 All Models

EUROPEAN DIN STYLE COIL
 Models 24, 34

BODY OPTIONS—see page 80

METERING TO 1/8" ORIFICE
 Models 24, 34, 54

METERING TO 3/16" ORIFICE
 Model 74

MANUAL OVERRIDE
 24*, 74

Note: Availability of certain options or combination of options may vary with quantity of units ordered - Consult representative or factory.

PORT OPTIONS—see page 81

BOTTOM ORIFICE PORT
 All Models

BOTTOM CAVITY PORT
 All Models

PORT 90° LEFT
 All Models except 54

MANIFOLD MOUNT
 All Models

FLANGE MOUNT
 Models 24, 74

PORT 90° RIGHT
 All Models except 54

MISCELLANEOUS OPTIONS—see page 76

SILVER SHADING RING
 All Models



ALUMINUM SHADING RING
 All Models

BUILT IN MUFFLER
 All Models

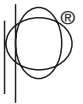
UNIVERSAL MOUNTING BRACKET
 Models 24, 34, 54





SERIES 20—MODEL 24



+MAX. OPER. PRESS. DIFF.		ORIFICE SIZE		CV FACTOR		VALVE NUMBER				REPAIR PACK WT. 0.25		
AC	DC	INLET	EXH.	INLET	EXH.	GROMMET HOUSING Grommet Valve WT. 1.06 LB. 1/4 NPT PORTS		CONDUIT HOUSING Conduit Valve WT. 1.13 LB. 1/4 NPT PORTS				
400	400	1/32	1/32	.024	.024	24GG7XGV	24GG9ZGV	24GG7XCV	24GG9ZCV	K24GGX		
150 (225)	150	3/64	1/16	.052	.095	24HJ7XGV	24HJ9ZGV	24HJ7XCV	24HJ9ZCV	K24HJX		
100 (150)	100	1/16	1/16	.095	.095	24JJ7XGV	24JJ9ZGV	24JJ7XCV	24JJ9ZCV	K24JJX		
100 (150)	100	1/16	3/32	.095	.156	24JK7XGV	24JK9ZGV ✓	24JK7XCV	24JK9ZCV	K24JKX		
100 (125)	100	1/16	1/8	.095	.284	24JN7XGV	24JN9ZGV	24JN7XCV	24JN9ZCV	K24JNX		
75 (90)	75	3/32	1/8	.156	.284	24KN7XGV	24KN9ZGV	24KN7XCV	24KN9ZCV	K24KNX		
30	30	1/8	1/8	.201	.284	24NN7XGV	24NN9ZGV	24NN7XCV	24NN9ZCV	K24NNX		

°VALVES WITH 1/8 SLEEVE ORIFICE ARE UL LISTED ONLY



SERIES 30—MODEL 34

+MAX. OPER. PRESS. DIFF.		ORIFICE SIZE		CV FACTOR		VALVE NUMBER				REPAIR PACK WT. 0.25		
AC	DC	INLET	EXH.	INLET	EXH.	GROMMET HOUSING Grommet Valve WT. 0.75 LB. 1/4 NPT PORTS		CONDUIT HOUSING Conduit Valve WT. 0.81 LB. 1/4 NPT PORTS				
300	300	1/32	1/32	.024	.024	34GG5XGV	34GG5XCV	34GG5XCV	34GG5XCV	K34GGX		
175	175	3/64	1/16	.052	.095	34HJ5XGV	34HJ5XCV ✓	34HJ5XCV	34HJ5XCV	K34HJX		
100	100	1/16	3/32	.095	.160	34JK5XGV	34JK5XCV	34JK5XCV	34JK5XCV	K34JKX		
60	60	3/32	1/8	.160	.275	34KN5XGV	34KN5XCV	34KN5XCV	34KN5XCV	K34KNX		

SERIES 50—MODEL 54

+MAX. OPER. PRESS. DIFF.		ORIFICE SIZE		CV FACTOR		VALVE NUMBER				REPAIR PACK WT. 0.25		
AC	DC	INLET	EXH.	INLET	EXH.	GROMMET HOUSING Grommet Valve WT. 0.38 LB. 1/4 NPT PORTS		CONDUIT HOUSING Conduit Valve WT. 0.44 LB. 1/4 NPT PORTS				
150	150	1/32	1/32	.020	.022	54GG8XGB	54GG8XCB	54GG8XCB	54GG8XCB	K54GGX		
125	125	3/64	3/64	.048	.055	54HH8XGB ✓	54HH8XCB	54HH8XCB	54HH8XCB	K54HHX		
100	75	1/16	1/16	.075	.075	54JJ8XGB	54JJ8XCB	54JJ8XCB	54JJ8XCB	K54JJX		
75	45	1/16	3/32	.075	.156	54JK8XGB	54JK8XCB	54JK8XCB	54JK8XCB	K54JKX		
50	50	3/32	3/32	.150	.156	54KK8XGB	54KK8XCB	54KK8XCB	54KK8XCB	K54KKX		
40	25	3/32	1/8	.150	.230	54KN8XGB	54KN8XCB	54KN8XCB	54KN8XCB	K54KNX		

SERIES 70—MODEL 74

+MAX. OPER. PRESS. DIFF.		ORIFICE SIZE		CV FACTOR		VALVE NUMBER				REPAIR PACK WT. 0.25		
AC	DC	INLET	EXH.	INLET	EXH.	GROMMET HOUSING Grommet Valve WT. 2.00 LB. 1/4 NPT PORTS		CONDUIT HOUSING Conduit Valve WT. 2.06 LB. 1/4 NPT PORTS				
350	350	1/16	1/16	.09	.09	74JJ9ZGV	74JJ9ZCV	74JJ9ZCV	74JJ9ZCV	K74JJX		
250	250	3/32	3/32	.22	.22	74KK9ZGV	74KK9ZCV	74KK9ZCV	74KK9ZCV	K74KKX		
175	175	1/8	1/8	.35	.35	74NN9ZGV	74NN9ZCV	74NN9ZCV	74NN9ZCV	K74NNX		
125	125	5/32	5/32	.45	.45	74009ZGV	74009ZCV	74009ZCV	74009ZCV	K7400X		
100	100	3/16	3/16	.50	.50	74PP9ZGV ✓	74PP9ZCV	74PP9ZCV	74PP9ZCV	K74PPX		

WHEN ORDERING VALVES OR REPAIR PACKS ADD VOLTAGE AND FREQUENCY TO COMPLETE VALVE NUMBER. EXAMPLES: VALVE (74KK9ZGV-120/60) REPAIR PACK (K74KKX-AC) See repair pack reference page 88

†Ratings in brackets are optional extended ratings; consult factory

NOTE: The above checked (✓) Valves, but with optional molded coils, are most popular based on sales and likely to be in Distributor stock.

SPECIFICATIONS—3-WAY DIRECTIONAL CONTROL

OPERATING CONDITIONS

Media: Air, water, and other fluids compatible with standard Buna seals. Hot water, steam gasoline, and many oils require special seal materials - Consult representative or factory. (Series 50 pressure ratings may change due to the viscosity of the liquid-consult factory for de-rating)

Valve Temperature Range: STANDARD VALVES – 0°F (-18°C) to 104°F (40°C) ambient; 0°F (-18°C) to 150°F (65°C) media. OPTIONAL VALVES – can tolerate much higher or much lower ambient and media temperatures. Consult factory for specifics.

Maximum Operating Pressure Differentials: See Catalog listings.

Burst Pressure: Series 20, 30, 50 - 5000 PSI Series 70 - 4000 PSI

Leakage: Bubble tight for standard valves

Vacuum: To 5 Microns - Consult factory

ELECTRICAL CHARACTERISTICS

Coil Voltage: Series 20 - 5 to 825 VAC 50-60 HZ. – 1.8 to 265V DC
 Series 30 - 5.2 to 650 VAC 50-60 HZ. – 2 to 240V DC
 Series 50 - 5.4 to 575 VAC 50-60 HZ. – 3.0 to 300V DC
 Series 70 - 12 to 1050 VAC 50-60 HZ. – 2.5 to

220V DC

Nominal Power:

Series	D.C.	A.C.	Series	D.C.	A.C.
20	9.5	8.7 Watts	50	7.0	6.0 Watts
30	8.0	8.0 Watts	70	16.0	18.0 Watts

Coil Construction: Non-molded Class A, Molded and potted Class F. (Class H optional)

Typical Response Time on Air: 4 - 16 Milliseconds—all series

MECHANICAL CHARACTERISTICS

Body: Stainless steel (standard) - Ser. 20, 50, & 70
 Brass (standard) - Ser. 30
 Brass (optional) - Ser. 20, 50, & 70 - Consult factory
 Aluminum (optional) - Ser. 50 - Consult factory

Orifice Diameter: See catalog listings

Porting: See catalog listings

Housing: Grommet & 1/2" NPT conduit - many options available.

Listings: Most valves are U.L. and CSA listed - Consult factory for specifics.

DE-ENERGIZED

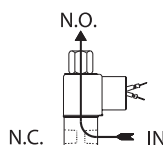

ENERGIZED

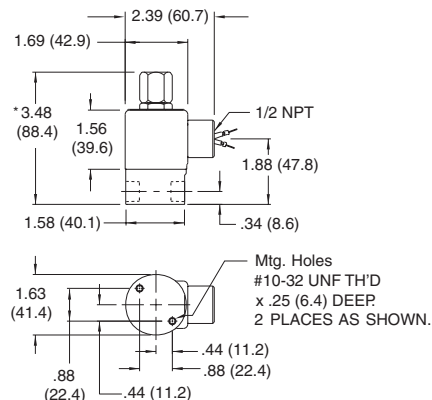
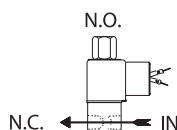

*ADD .165 (4.2) FOR SPADE TERMINAL COIL OPTION

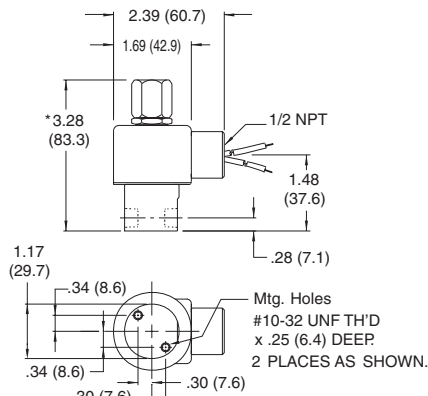

*ADD .100 (2.5) FOR SPADE TERMINAL COIL OPTION

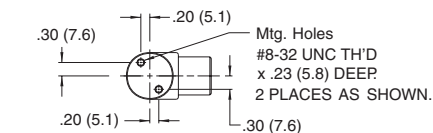
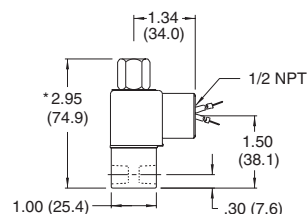

*ADD .232 (5.9) FOR SPADE TERMINAL COIL OPTION

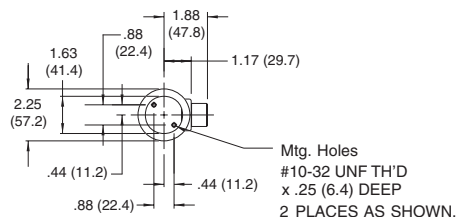
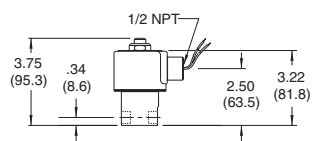

OPTIONS AVAILABLE: – 3 WAY DIRECTIONAL CONTROL

FOR ILLUSTRATED OPTIONS SEE PAGES 76-81

FOR FLOW CHARTS SEE PAGES 95-97

HOUSING OPTIONS—see page 78

STRAIN RELIEF CONNECTOR

All Models

SINGLE AUTOMOTIVE

All Models except 55

DOUBLE AUTOMOTIVE

All Models except 55

“AN” CONNECTOR

All Models

SPLICE BOX HOUSING

All Models

JIC HOUSING

Model 25

YOKE

All Models

MOUNTING BRACKET

All Models

COIL OPTIONS—see page 79

MOLDED COIL

All Models

THIRD WIRE GROUND

All conduit Models

POTTED COIL & HOUSING

All Models

SPADE TERMINAL COIL - MOLDED

Models 25, 35, 55

HIGH TEMPERATURE MOLDED COIL

All Models

EUROPEAN DIN STYLE COIL

Models 25, 35

BODY OPTIONS—see page 80

METERING TO 1/8" ORIFICE

Models 25, 35, 55

METERING TO 3/16" ORIFICE

Model 75

METERED BYPASS

Model 25

MANUAL OVERRIDE

Models 25*, 75

Note: Availability of certain options or combination of options may vary with quantity of units ordered - Consult representative or factory.

PORT OPTIONS—see page 81

BOTTOM ORIFICE PORT

All Models

BOTTOM CAVITY PORT

All Models

PORT 90° LEFT

All Models except 55

MANIFOLD MOUNT

All Models

FLANGE MOUNT

Models 25, 75

PORT 90° RIGHT

All Models except 55

MISCELLANEOUS OPTIONS—see page 76

SILVER SHADING RING

All Models

ALUMINUM SHADING RING

All Models

BUILT IN MUFFLER

All Models

UNIVERSAL MOUNTING BRACKET

Models 25, 35, 55

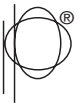

SOLENOID VALVES . . .

SERIES 20—MODEL 25

+MAX. OPER. PRESS. DIFF.		ORIFICE SIZE		CV FACTOR		GROMMET HOUSING		CONDUIT HOUSING		REPAIR PACK WT. 0.25
AC	DC	INLET	EXH.	INLET	EXH.	1/2 NPT PORTS	1/4 NPT PORTS	1/2 NPT PORTS	1/4 NPT PORTS	
500	500	1/32*	1/32	.024*	.024	25GG7XGV	25GG9ZGV	25GG7XCV	25GG9ZCV	K25GGX
235 (400)	235 (300)	3/64*	3/64	.052*	.052	25HH7XGV	25HH9ZGV	25HH7XCV	25HH9ZCV	K25HHX
200 (225)	200 (200)	1/16*	3/64	.095*	.052	25JH7XGV	25JH9ZGV	25JH7XCV	25JH9ZCV	K25JHX
150 (225)	150 (200)	1/16*	1/16	.095*	.095	25JJ7XGV ✓	25JJ9ZGV	25JJ7XCV	25JJ9ZCV	K25JJX
100 (150)	100 (125)	3/32*	3/32	.156*	.156	25KK7XGV	25KK9ZGV	25KK7XCV	25KK9ZCV	K25KKX
100 (125)	100	1/8*	3/32	.284*	.156	25NK7XGV	25NK9ZGV	25NK7XCV	25NK9ZCV	K25NKX
35 (40)	35 (40)	1/8*	1/8	.284*	.201	25NN7XGV	25NN9ZGV	25NN7XCV	25NN9ZCV	K25NNX

*VALVES WITH 1/8 SLEEVE ORIFICE ARE UL LISTED ONLY



3-WAY DIRECTIONAL CONTROL GROMMET



3-WAY DIRECTIONAL CONTROL CONDUIT

SERIES 30—MODEL 35

+MAX. OPER. PRESS. DIFF.		ORIFICE SIZE		CV FACTOR		GROMMET HOUSING		CONDUIT HOUSING		REPAIR PACK WT. 0.25
AC	DC	INLET	EXH.	INLET	EXH.	1/2 NPT PORTS	1/4 NPT PORTS	1/2 NPT PORTS	1/4 NPT PORTS	
300	300	1/32*	1/32	.024*	.024	35GG5XGV		35GG5XCV		K35GGX
175	175	3/64*	1/16	.052*	.095	35HJ5XGV ✓		35HJ5XCV		K35HJX
125	125	1/16*	1/16	.095*	.095	35JJ5XGV		35JJ5XCV		K35JJX
75	75	3/32*	3/32	.160*	.160	35KK5XGV		35KK5XCV		K35KKX
50	50	1/8*	3/32	.275*	.160	35NK5XGV		35NK5XCV		K35NKX



3-WAY DIRECTIONAL CONTROL GROMMET



3-WAY DIRECTIONAL CONTROL CONDUIT

SERIES 50—MODEL 55

+MAX. OPER. PRESS. DIFF.		ORIFICE SIZE		CV FACTOR		GROMMET HOUSING		CONDUIT HOUSING		REPAIR PACK WT. 0.25
AC	DC	INLET	EXH.	INLET	EXH.	1/2 NPT PORTS	1/4 NPT PORTS	1/2 NPT PORTS	1/4 NPT PORTS	
300	200	1/32*	1/32	.022*	.020	55GG8XGB		55GG8XCB		K55GGX
200	100	3/64*	3/64	.055*	.048	55HH8XGB		55HH8XCB		K55HHX
100	50	1/16*	1/16	.075*	.075	55JJ8XGB ✓		55JJ8XCB		K55JJX
75	25	3/32*	1/16	.156*	.075	55KJ8XGB		55KJ8XCB		K55KJX
75	40	3/32*	3/32	.156*	.150	55KK8XGB		55KK8XCB		K55KKX
45	25	1/8*	3/32	.230*	.150	55NK8XGB		55NK8XCB		K55NKX



3-WAY DIRECTIONAL CONTROL GROMMET



3-WAY DIRECTIONAL CONTROL CONDUIT

SERIES 70—MODEL 75

+MAX. OPER. PRESS. DIFF.		ORIFICE SIZE		CV FACTOR		GROMMET HOUSING		CONDUIT HOUSING		REPAIR PACK WT. 0.25
AC	DC	INLET	EXH.	INLET	EXH.	1/2 NPT PORTS	1/4 NPT PORTS	1/2 NPT PORTS	1/4 NPT PORTS	
350	350	1/16*	1/16	.09*	.09	75JJ9ZGV		75JJ9ZCV		K75JJX
250	250	3/32*	3/32	.22*	.22	75KK9ZGV		75KK9ZCV		K75KKX
175	175	1/8*	1/8	.35*	.35	75NN9ZGV		75NN9ZCV		K75NNX
125	125	5/32*	5/32	.45*	.45	75009ZGV ✓		75009ZCV		K7500X
100	100	3/16*	3/16	.50*	.50	75PP9ZGV		75PP9ZCV		K75PPX



3-WAY DIRECTIONAL CONTROL GROMMET



3-WAY DIRECTIONAL CONTROL CONDUIT

WHEN ORDERING VALVES OR REPAIR PACKS ADD VOLTAGE AND FREQUENCY TO COMPLETE VALVE NUMBER. EXAMPLES: VALVE (75KK9ZGV-120/60) REPAIR PACK (K75KKX-AC) See repair pack reference page 82

*Normally closed orifice

†Ratings in brackets are optional extended ratings; consult factory

NOTE: The above checked (✓) Valves, but with optional molded coils, are most popular based on sales and likely to be in Distributor stock.

SPECIFICATIONS—3-WAY MULTI-PURPOSE

OPERATING CONDITIONS

Media: Air, water, and other fluids compatible with standard Buna seals. Hot water, steam gasoline, and many oils require special seal materials - Consult representative or factory. (Series 50 pressure ratings may change due to the viscosity of the liquid-consult factory for de-rating)

Valve Temperature Range: STANDARD VALVES – 0°F (-18°C) to 104°F (40°C) ambient; 0°F (-18°C) to 150°F (65°C) media. OPTIONAL VALVES – can tolerate much higher or much lower ambient and media temperatures. Consult factory for specifics.

Maximum Operating Pressure Differentials: See Catalog listings.

Burst Pressure: Series 20, 30, 50 - 5000 PSI Series 70 - 4000 PSI

Leakage: Bubble tight for standard valves

Vacuum: To 5 Microns - Consult factory

ELECTRICAL CHARACTERISTICS

Coil Voltage: Series 20 - 5 to 825 VAC 50-60 HZ. – 1.8 to 265V DC
Series 30 - 5.2 to 650 VAC 50-60 HZ. – 2 to 240V DC
Series 50 - 5.4 to 575 VAC 50-60 HZ. – 3.0 to 300V

DC Series 70 - 12 to 1050 VAC 50-60 HZ. – 2.5 to 220V

Nominal Power:

Series	D.C.	A.C.	Series	D.C.	A.C.
20	9.5	8.7 Watts	50	7.0	6.0 Watts
30	8.0	8.0 Watts	70	16.0	18.0 Watts

Coil Construction: Non-molded Class A, Molded and potted Class F. (Class H optional)

Typical Response Time on Air: 4 - 16 Milliseconds—all series

MECHANICAL CHARACTERISTICS

Body: Stainless steel (standard) - Ser. 20, 50, & 70
Brass (standard) - Ser. 30
Brass (optional) - Ser. 20, 50, & 70 - Consult factory
Aluminum (optional) - Ser. 50 - Consult factory

Orifice Diameter: See catalog listings

Porting: See catalog listings

Housing: Grommet & 1/2" NPT conduit - many options available.

Listings: Most valves are U.L. and CSA listed - Consult factory for specifics.

OPTIONS AVAILABLE: – 3 WAY MULTI-PURPOSE FOR ILLUSTRATED OPTIONS SEE PAGES 76-81 FOR FLOW CHARTS SEE PAGES 95-97

HOUSING OPTIONS—see page 78

STRAIN RELIEF CONNECTOR
All Models

SINGLE AUTOMOTIVE
All Models except 56

DOUBLE AUTOMOTIVE
All Models except 56

"AN" CONNECTOR
All Models

SPLICE BOX HOUSING
All Models

JIC HOUSING
Model 26

YOKE
All Models

MOUNTING BRACKET
All Models

COIL OPTIONS—see page 79

MOLDED COIL
All Models

THIRD WIRE GROUND
All conduit Models

POTTED COIL & HOUSING

SPADE TERMINAL COIL - MOLDED
Models 26, 36, 56

SPADE TERMINAL COIL -NON-MOLDED
Models 26, 36, 56

HIGH TEMPERATURE MOLDED COIL
All Models

EUROPEAN DIN STYLE COIL
Models 26, 36

BODY OPTIONS—see page 80

METERING TO 3/32" ORIFICE
Models 56

METERING TO 1/8" ORIFICE
Model 26, 36

METERING TO 3/16" ORIFICE
Model 76

METERED BYPASS
Model 26

MANUAL OVERRIDE
Models 26, 76

PORT OPTIONS—see page 81

BOTTOM ORIFICE PORT
All Models

BOTTOM CAVITY PORT
All Models

PORT 90° LEFT
Models 26, 36, 76

MANIFOLD MOUNT
All Models

FLANGE MOUNT
Models 26, 76

PORT 90° RIGHT
Models 26, 36, 76

MISCELLANEOUS OPTIONS—see page 76

SILVER SHADING RING
All Models

ALUMINUM SHADING RING
All Models

UNIVERSAL MOUNTING BRACKET
Models 26, 36, 56

Note: Availability of certain options or combination of options may vary with quantity of units ordered - Consult representative or factory.

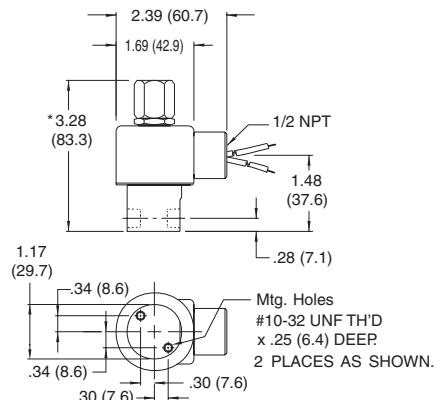
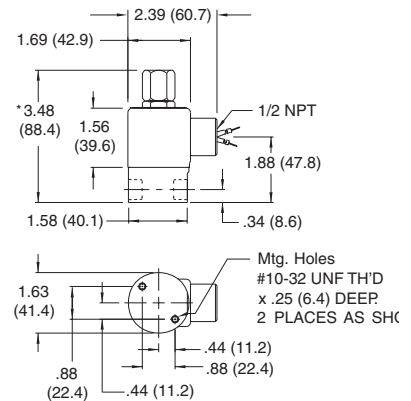

*ADD .100 (2.5) FOR SPADE TERMINAL COIL OPTION

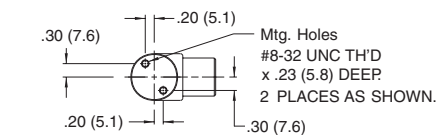
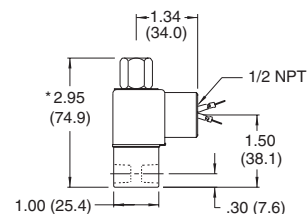

*ADD .232 (5.9) FOR SPADE TERMINAL COIL OPTION

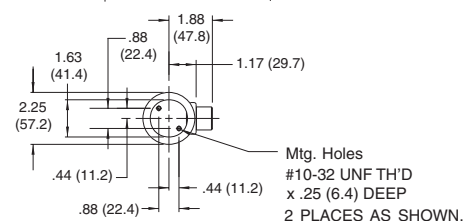
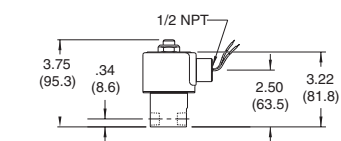

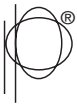

SERIES 20—MODEL 26

+MAX. OPER. PRESS. DIFF.		ORIFICE SIZE		CV FACTOR		VALVE NUMBER			
AC	DC	INLET EXH.		INLET EXH.		GROMMET HOUSING		CONDUIT HOUSING	
						Grommet Valve WT. 1.13 LB.		Conduit Valve WT. 1.19 LB	
						1/8 NPT	1/4 NPT	1/8 NPT	1/4 NPT
						PORTS	PORTS	PORTS	PORTS
400	400	1/32*	1/32	.024*	.024	26GG7XGV	26GG9ZGV	26GG7XCV	26GG9ZCV
150	150	3/64*	3/64	.052*	.052	26HH7XGV	26HH9ZGV	26HH7XCV	26HH9ZCV
100	100	1/16*	1/16	.095*	.095	26JJ7XGV	26JJ9ZGV	26JJ7XCV	26JJ9ZCV ✓
75	75	3/32*	3/32	.156*	.156	26KK7XGV	26KK9ZGV	26KK7XCV	26KK9ZCV
35	35	1/8*	1/8	.284*	.201	°26NN7XGV	°26NN9ZGV	°26NN7XCV	°26NN9ZCV

°VALVE WITH 1/8 SLEEVE ORIFICE ARE UL LISTED ONLY

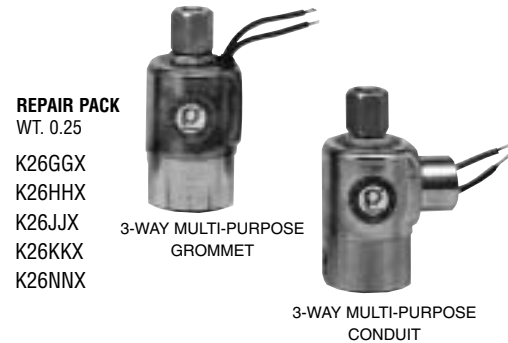

SERIES 30—MODEL 36

+MAX. OPER. PRESS. DIFF.		ORIFICE SIZE		CV FACTOR		VALVE NUMBER			
AC	DC	INLET EXH.		INLET EXH.		GROMMET HOUSING		CONDUIT HOUSING	
						Grommet Valve WT. 0.75 LB.		Conduit Valve WT. 0.81 LB	
						1/8 NPT PORTS		1/8 NPT PORTS	
300	300	1/32*	1/32	.024*	.024	36GG5XGV		36GG5XCV	
150	150	3/64*	3/64	.052*	.052	36HH5XGV		36HH5XCV ✓	
75	75	1/16*	1/16	.095*	.095	36JJ5XGV		36JJ5XCV	
50	30	3/32*	3/32	.160*	.160	36KK5XGV		36KK5XCV	

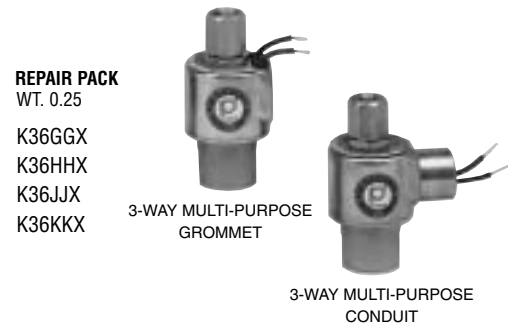

SERIES 50—MODEL 56

+MAX. OPER. PRESS. DIFF.		ORIFICE SIZE		CV FACTOR		VALVE NUMBER			
AC	DC	INLET EXH.		INLET EXH.		GROMMET HOUSING		CONDUIT HOUSING	
						Grommet Valve WT. 0.38 LB.		Conduit Valve WT. 0.44 LB	
						1/8 NPT PORTS		1/8 NPT PORTS	
125	125	1/32*	1/32	.022*	.020	56GG8XGB		56GG8XCB	
100	100	3/64*	3/64	.055*	.048	56HH8XGB		56HH8XCB	
65	50	1/16*	1/16	.075*	.075	56JJ8XGB ✓		56JJ8XCB	
25	25	3/32*	3/32	.156*	.150	56KK8XGB		56KK8XCB	

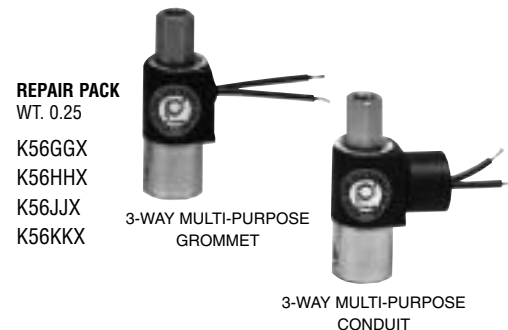

SERIES 70—MODEL 76

+MAX. OPER. PRESS. DIFF.		ORIFICE SIZE		CV FACTOR		VALVE NUMBER			
AC	DC	INLET EXH.		INLET EXH.		GROMMET HOUSING		CONDUIT HOUSING	
						Grommet Valve WT. 2.00 LB.		Conduit Valve WT. 2.06 LB	
						1/4 NPT PORTS		1/4 NPT PORTS	
225	225	1/16*	1/16	.09*	.09	76JJ9ZGV		76JJ9ZCV	
150	150	3/32*	3/32	.22*	.22	76KK9ZGV		76KK9ZCV ✓	
100	100	1/8*	1/8	.35*	.35	76NN9ZGV		76NN9ZCV	
75	75	5/32*	5/32	.45*	.45	76009ZGV		76009ZCV	
60	60	3/16*	3/16	.50*	.50	76PP9ZGV		76PP9ZCV	



WHEN ORDERING VALVES OR REPAIR PACKS ADD VOLTAGE AND FREQUENCY TO COMPLETE VALVE NUMBER.

EXAMPLES: VALVE (75KK9ZGV-120/60) REPAIR PACK (K75KKX-AC) See repair pack reference page 82

*Normally Closed Orifice

NOTE: The above checked (✓) Valves, but with optional molded coils, are most popular based on sales and likely to be in Distributor stock.

SPECIFICATIONS — 2-WAY — 3-WAY EXPLOSION PROOF VALVES

OPERATING CONDITIONS

Media: Air, water, and other fluids, compatible with standard Buna seals. Hot water, steam, gasoline, and many oils require special seal materials.
(Consult representative or factory.)

Valve Temperature Range: Standard Valve-0°F(-18°C) to 104°F(40°C) ambient;
0°F (-18°C) to 150°F(65°C) media. Optional Valves can tolerate much higher or much lower ambient and media temperatures. Consult factory for specifics.

Maximum Operating Pressure Differentials: See Catalog Listings

Burst Pressure: 5000 PSI

Leakage: Bubble tight for standard valves

Vacuum: To 5 Microns - Consult factory

ELECTRICAL CHARACTERISTICS

Coil Voltage: 5 to 825 VAC 50-60 HZ - 1.8 to 265V DC

Nominal Power:	<u>Wattage</u>
	<u>A.C. 7.3 Watts</u>
	<u>D.C. 9.5 Watts</u>

Coil Construction: Molded coil and third wire ground (standard)

Typical Response Time on Air: 4-16 Milliseconds

MECHANICAL CHARACTERISTICS

Body: Stainless steel

Orifice Diameter: See catalog listings

Porting: See catalog listings

Housing: 1/2" NPT conduit

Listings: Valves are U.L. Listed and CSA Certified for Hazardous Locations—Class I, Div 1, Group C and D - Class II, Div 1, Groups E, F, and G; Div 2 Groups A,B,C,D,E,F, and G.

OPTIONS AVAILABLE: — 3 WAY MULTI-PURPOSE
FOR ILLUSTRATED OPTIONS SEE PAGES 76-81
FOR FLOW CHARTS SEE PAGES 95-97

HOUSING OPTIONS – see page 78

MOUNTING BRACKET
All Models

COIL OPTIONS – see page 79

MOLDED COIL
Standard

POTTED COIL & HOUSING
All models

**HIGH TEMPERATURE
MOLDED COIL**
All Models

THIRD WIRE GROUND
All Models

BODY OPTIONS – see page 80

FINE METERING
All Models

METERING TO 1/8" ORIFICE
All Models

METERING TO 1/4" ORIFICE
Models E22, E23

METERED BYPASS
Models E22, E23

MANUAL OVERRIDE
All Models*

METERED EXHAUST PORT
Model E23

PORT OPTIONS – see page 81

BOTTOM ORIFICE PORT
Models E22**, E23**

BOTTOM CAVITY PORT
Models E22**, E23**

PORT 90° LEFT
Models E22, E23

MANIFOLD MOUNT
Models E22**, E23**

FLANGE MOUNT
Models E22**, E23**

PORT 90° RIGHT
Models E22, E23

MISCELLANEOUS
Options – see page 76

SILVER SHADING RING
All Models

ALUMINUM SHADING RING
All Models

BUILT IN MUFFLER
All Models

Note: Availability of certain options or combination of options may vary with quantity of units ordered – consult representative or factory.

* Not available over 250 psi

** Not available in 1/4" orifice

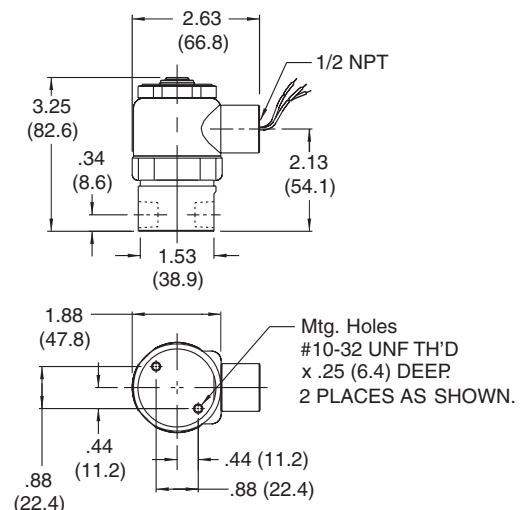
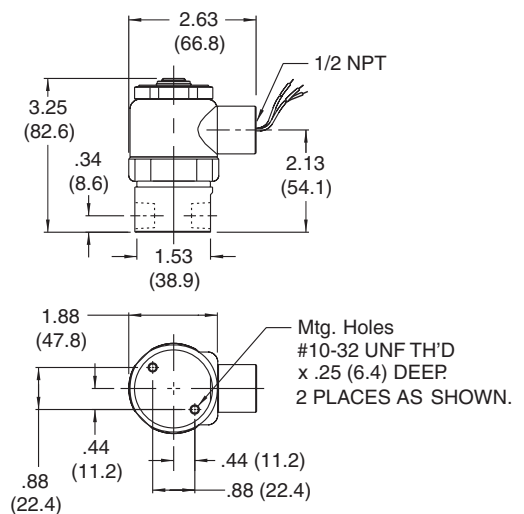
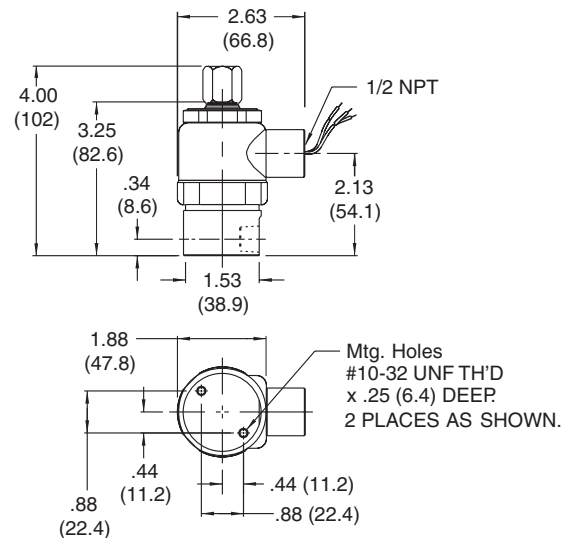

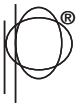

SOLENOID VALVES . . .

SERIES 20 — MODEL E21—2-WAY NORMALLY OPEN

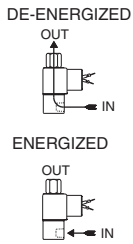

	† MAX. OPER. PRESS DIFF.		ORIFICE SIZE	CV FACTOR
	AC	DC		
	400 (700)	400 (700)	1/32	.024
	235 (500)	235 (500)	3/64	.053
	150 (350)	150 (350)	1/16	.095
	100 (150)	100 (150)	3/32	.156
	35 (40)	35 (40)	1/8	.227

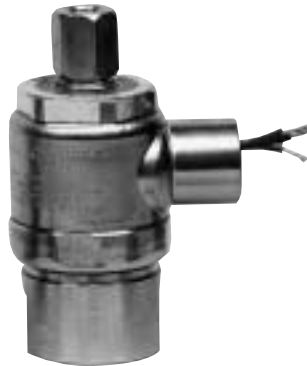

VALVE NUMBER CONDUIT HOUSING	
1/8 NPT PORTS	1/4 NPT PORTS
E21G7XCCM	E21G9ZCCM
E21H7XCCM	E21H9ZCCM
E21J7XCCM	E21J9ZCCM
E21K7XCCM	E21K9ZCCM ✓
°E21N7XCCM	°E21N9ZCCM

°VALVES WITH 1/8 SLEEVE ORIFICE ARE NOT UL NOR CSA LISTED

SERIES 20 — MODEL E22—2-WAY NORMALLY CLOSED

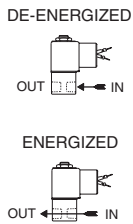

	† MAX. OPER. PRESS DIFF.		ORIFICE SIZE	CV FACTOR
	AC	DC		
	500	500	1/32	.024
	250 (500)	250 (500)	3/64	.052
	200 (400)	200 (400)	1/16	.095
	125 (300)	125 (250)	3/32	.156
	100 (200)	100 (200)	1/8	.284
	75	50	5/32	.404
	50	25	3/16	.500
	20	5	1/4	.700



VALVE NUMBER CONDUIT HOUSING	
1/8 NPT PORTS	1/4 NPT PORTS
E22G7DCCM	E22G9DCCM
E22H7DCCM	E22H9DCCM
E22J7DCCM	E22J9DCCM
E22K7DCCM	E22K9DCCM
E22N7DCCM	E22N9DCCM ✓
E22O7DCCM	E22O9DCCM
E22P7DCCM	E22P9DCCM
E22R7DCCM	E22R9DCCM ✓

SERIES 20 — MODEL E23—3-WAY NORMALLY CLOSED — EXHAUST TO ATMOSPHERE

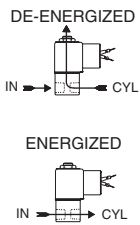

	† MAX. OPER. PRESS DIFF.		ORIFICE SIZE		CV FACTOR	
	AC	DC	INLET	EXH.	INLET	EXH.
	400	400	1/32	1/32	.024	.024
	150 (200)	150 (200)	3/64	1/16	.052	.095
	100 (135)	100 (135)	1/16	1/16	.095	.095
	100 (135)	100 (135)	1/16	3/32	.095	.156
	75 (100)	75 (100)	3/32	3/32	.156	.156
	50 (70)	50 (70)	1/8	3/32	.284	.156
	35 (40)	35 (40)	1/8	1/8	.284	.227
	20	20	3/16	3/32	.500	.156
	20	20	3/16	1/8	.500	.227
	15	—	1/4	3/32	.700	.156
	15	—	1/4	1/8	.700	.227



VALVE NUMBER CONDUIT HOUSING	
1/8 NPT PORTS	1/4 NPT PORTS
E23GG7DCCM	E23GG9DCCM
E23HJ7DCCM	E23HJ9DCCM
E23JJ7DCCM	E23JJ9DCCM
E23JK7DCCM	E23JK9DCCM
E23KK7DCCM	E23KK9DCCM ✓
E23NK7DCCM	E23NK9DCCM
°E23NN7DCCM	E23NN9DCCM
E23PK7DCCM	E23PK9DCCM
°E23PN7DCCM	E23PN9DCCM
E23RK7DCCM	E23RK9DCCM
°E23RN7DCCM	E23RN9DCCM

°VALVES WITH 1/8 SLEEVE ORIFICE ARE NOT UL NOR CSA LISTED

† Ratings in brackets are optional extended ratings; consult factory

When ordering add voltage and frequency to complete valve number. Example: (E23GG7DCCM-120/60)

NOTE: The above checked (✓) Valves, but with optional molded coils, are most popular based on sales and likely to be in Distributor stock.

SPECIFICATIONS — 3-WAY EXPLOSION PROOF VALVES

OPERATING CONDITIONS

Media: Air, water, and other fluids, compatible with standard Buna seals.
Hot water, steam, gasoline, and many oils require special seal materials - Consult representative or factory.

Valve Temperature Range: 0°F (-18°C) to a maximum of 221°F (105°C) including coil heat rise, ambient and media temperatures. Other temperature ranges available on request—along with specific application parameter information specified.

Maximum Operating Pressure Differentials: See Catalog Listings

Burst Pressure: 5000 PSI

Leakage: Bubble tight for standard valves

Vacuum: To 5 Microns - Consult factory

ELECTRICAL CHARACTERISTICS

Coil Voltage: 5 to 825 VAC 50-60 HZ - 1.8 to 265V DC

Nominal Power:

Wattage
A.C. 7.3 Watts
D.C. 9.5 Watts

Coil Construction: Molded coil and third wire ground (standard)

Typical Response Time on Air: 4-16 Milliseconds

MECHANICAL CHARACTERISTICS

Body: Stainless steel

Orifice Diameter: See catalog listings

Porting: See catalog listings

Housing: 1/2" NPT conduit

Listings: Valves are U.L. Listed and CSA Certified for Hazardous Locations—Class I, Div 1, Group C and D - Class II, Div 1, Groups E, F, and G; Div 2 Groups A,B,C,D,E,F, AND G.

OPTIONS AVAILABLE — 3-WAY EXPLOSION PROOF

FOR ILLUSTRATED OPTIONS SEE PAGES 76-81
FOR FLOW CHARTS SEE PAGES 95-97

HOUSING OPTIONS – see page 78

MOUNTING BRACKET
All Models

COIL OPTIONS – see page 79

MOLDED COIL
Standard

POTTED COIL & HOUSING
All models

HIGH TEMPERATURE MOLDED COIL
All Models

BODY OPTIONS – see page 80

METERING TO 1/8" ORIFICE
All Models

METERING TO 1/4" ORIFICE
Models E23

METERED BYPASS
Models E23, E25, E26

MANUAL OVERRIDE
All Models*

METERED EXHAUST PORT
Model E23, E25, E26

PORT OPTIONS – see page 81

BOTTOM ORIFICE PORT
All Models

BOTTOM CAVITY PORT
Models E23**, E24, E25, E26

PORT 90° LEFT
All Models

MANIFOLD MOUNT
Models E23**, E24, E25, E26

FLANGE MOUNT
Models E23**, E24, E25, E26

PORT 90° RIGHT
All Models

MISCELLANEOUS
Options – see page 76

SILVER SHADING RING
All Models

ALUMINUM SHADING RING
All Models

BUILT IN MUFFLER
All Models

Note: Availability of certain options or combination of options may vary with quantity of units ordered – consult representative or factory.

* Not available over 250 psi

** Not available in 1/4" orifice

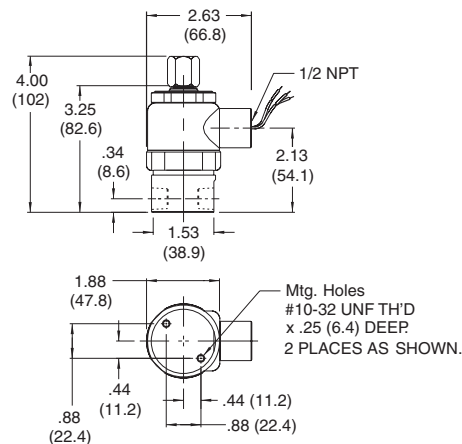
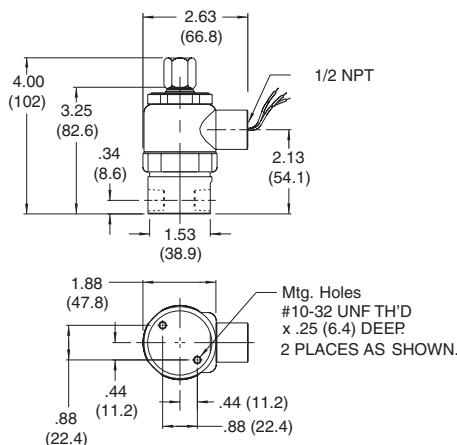
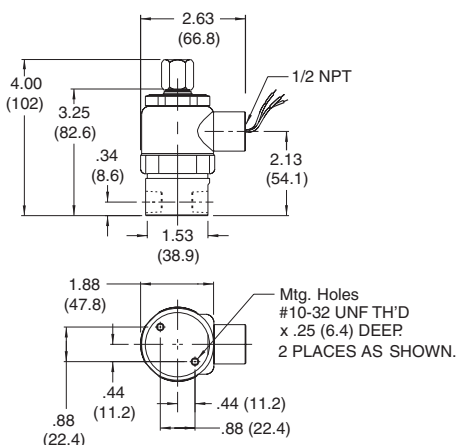
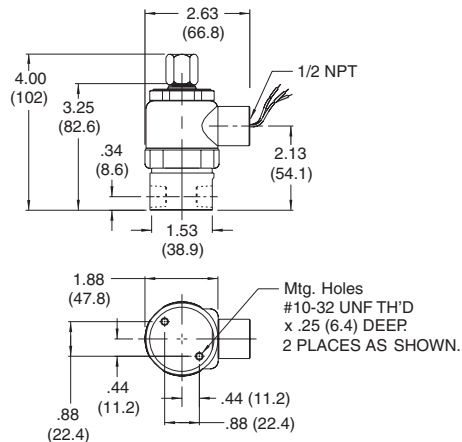



**PETER
PAUL**

SOLENOID VALVES . . .

SERIES 20 — MODEL E23—3-WAY NORMALLY CLOSED —PIPED EXHAUST

DE-ENERGIZED IN → EXH. ↑ CYL →	† MAX. OPER. PRESS DIFF.		ORIFICE SIZE		CV FACTOR		VALVE NUMBER CONDUIT HOUSING	
	AC	DC	INLET	EXH.	INLET	EXH.	1/8 NPT PORTS	1/4 NPT PORTS
ENERGIZED IN → EXH. ↑ CYL →	400	400	1/32	1/32	.024	.024	E23GG7XCCM	E23GG9ZCCM
	150 (200)	150 (200)	3/64	1/16	.052	.095	E23HJ7XCCM	E23HJ9ZCCM
	100 (135)	100 (135)	1/16	1/16	.095	.095	E23JJ7XCCM	E23JJ9ZCCM
	100 (135)	100 (135)	1/16	3/32	.095	.156	E23JK7XCCM	E23JK9ZCCM
	75 (100)	75 (100)	3/32	3/32	.156	.156	E23KK7XCCM	E23KK9ZCCM ✓
	50 (70)	50 (70)	1/8	3/32	.284	.156	E23NK7XCCM	E23NK9ZCCM
	35 (40)	35 (40)	1/8	1/8	.284	.227	°E23NN7XCCM	E23NN9ZCCM
	20 —	20 —	3/16	3/32	.500	.156	E23PK7XCCM	E23PK9ZCCM
	20 —	20 —	3/16	1/8	.500	.227	°E23PN7XCCM	°E23PN9ZCCM
	15 —	15 —	1/4	3/32	.700	.156	E23RK7XCCM	E23RK9ZCCM
15 —	15 —	1/4	1/8	.700	.227	°E23RN7XCCM	°E23RN9ZCCM	

°VALVES WITH 1/8 SLEEVE ORIFICE ARE NOT UL NOR CSA APPROVED

SERIES 20 — MODEL E24—3-WAY NORMALLY OPEN

DE-ENERGIZED IN → EXH. ↓ CYL →	† MAX. OPER. PRESS DIFF.		ORIFICE SIZE		CV FACTOR		VALVE NUMBER CODUIT HOUSING	
	AC	DC	INLET	EXH.	INLET	EXH.	1/8 NPT PORTS	1/4 NPT PORTS
ENERGIZED IN → EXH. ↓ CYL →	400	400	1/32	1/32	.024	.024	E24GG7XCCM	E24GG9ZCCM
	150 (225)	150 (225)	3/64	1/16	.052	.095	E24HJ7XCCM	E24HJ9ZCCM
	100 (150)	100 (150)	1/16	1/16	.095	.095	E24JJ7XCCM	E24JJ9ZCCM
	100 (125)	100 (125)	1/16	1/8	.095	.284	E24JN7XCCM	E24JN9ZCCM
	75 (90)	75 (90)	3/32	1/8	.156	.284	E24KN7XCCM	E24KN9ZCCM ✓
	30	30	1/8	1/8	.227	.284	°E24NN7XCCM	°E24NN9ZCCM

°VALVES WITH 1/8 SLEEVE ORIFICE ARE NOT UL NOR CSA APPROVED

SERIES 20 — MODEL E25—3-WAY DIRECTIONAL CONTROL

DE-ENERGIZED N.C. → N.O. ↑ IN →	† MAX. OPER. PRESS DIFF.		ORIFICE SIZE		CV FACTOR		VALVE NUMBER CODUIT HOUSING	
	AC	DC	INLET	EXH.	INLET	EXH.	1/8 NPT PORTS	1/4 NPT PORTS
ENERGIZED N.C. → N.O. ↑ IN →	500	500	1/32*	1/32	.024*	.024	E25GG7XCCM	E25GG9ZCCM
	235 (400)	235 (300)	3/64*	3/64	.052*	.052	E25HH7XCCM	E25HH9ZCCM
	200 (225)	200 (200)	1/16*	3/64	.095*	.052	E25JH7XCCM	E25JH9ZCCM
	150 (225)	150 (200)	1/16*	1/16	.095*	.095	E25JJ7XCCM	E25JJ9ZCCM
	100 (150)	100 (125)	3/32*	3/32	.156*	.156	E25KK7XCCM	E25KK9ZCCM
	100 (125)	100 (125)	1/8*	3/32	.284*	.156	E25NK7XCCM	E25NK9ZCCM ✓
	35 (40)	35 (40)	1/8*	1/8	.284*	.227	°E25NN7XCCM	°E25NN9ZCCM

°VALVES WITH 1/8 SLEEVE ORIFICE ARE NOT UL NOR CSA APPROVED

SERIES 20 — MODEL E26—3-WAY MULTI-PURPOSE

DE-ENERGIZED N.C. → N.O. ↑ COM. →	† MAX. OPER. PRESS DIFF.		ORIFICE SIZE		CV FACTOR		VALVE NUMBER CODUIT HOUSING	
	AC	DC	INLET	EXH.	INLET	EXH.	1/8 NPT PORTS	1/4 NPT PORTS
ENERGIZED N.C. → N.O. ↑ COM. →	400	400	1/32*	1/32	.024*	.024	E26GG7XCCM	E26GG9ZCCM
	150	150	3/64*	3/64	.052*	.052	E26HH7XCCM	E26HH9ZCCM
	100	100	1/16*	1/16	.095*	.095	E26JJ7XCCM	E26JJ9ZCCM ✓
	75	75	3/32*	3/32	.156*	.156	E26KK7XCCM	E26KK9ZCCM
	35	35	1/8*	1/8	.284*	.277	°E26NN7XCCM	°E26NN9ZCCM

°VALVES WITH 1/8 SLEEVE ORIFICE ARE NOT UL NOR CSA APPROVED

* Normally Closed Orifice

† Ratings in brackets are optional extended ratings; consult factory

When ordering add voltage and frequency to complete valve number. Example: (E26GG7XCCM-120/60)

NOTE: The above checked (✓) Valves are most popular based on sales and likely to be in Distributor stock.

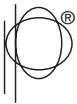

PETER PAUL

SERIES 20 MODEL H21 & EH21 2-WAY NORMALLY OPEN HIGH PRESSURE



Model H21 with standard body

2-Way Normally Open

Coil Voltage: DC Only

Maximum Operating Pressure Differential: 2000 PSI (Gas or Liquid)

Orifice Size: .6 mm

CV Factor: .010

Filtration: Down to 60 microns or less is recommended

Burst Pressure: 5000 PSI

Valve Temperature Range: Standard Valves - 0°F (- 18°C) to 104°F (40°C) ambient; 0°F (- 18°C) to 150°F (65°C) media. Optional Valves - can tolerate much higher or much lower ambient and media temperatures. Consult factory for specifications.



EH21

EXCLUSIVE FEATURES INCLUDE:

A precision stainless steel **PLUNGER** that supplies the necessary impact force to energize valve.

A Kel-F® **PIN**† which functions as a sealing element, that is carefully machined for maximum concentricity and fine finish.

The **ORIFICE GUIDE** is one piece, for near perfect alignment. This means bubble-tight sealing from low pressures right up to maximum pressure rating with the bonus of longer life. The one piece Orifice/Guide can be pressed into almost any standard cavity making it available as an operator for special customer installations.

† Other pin materials available. consult factory

PATENTED

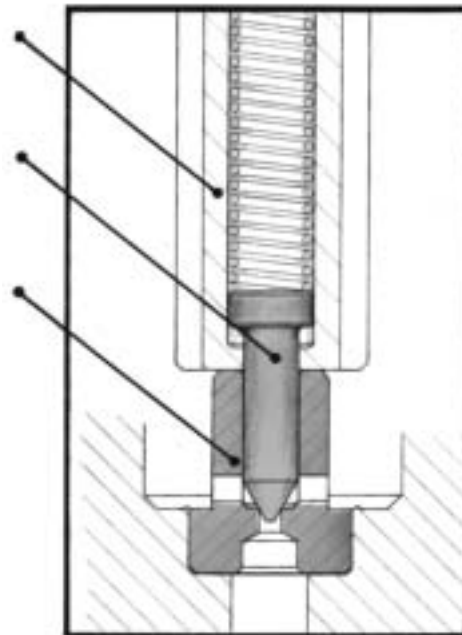

OTHER FEATURES INCLUDE:

Simple construction...

Only 2 moving parts

Available in both standard and explosion proof construction

1/8 or 1/4 NPT ports

PRINCIPLES OF OPERATION

When the valve coil is energized, the plunger is drawn towards the sleeve end stop. The plunger is allowed to accelerate freely for a short distance before it makes contact with the pin shoulder. Upon contact it imparts considerable force on the pin causing it to lift off the seat. A return spring provides the return force, directly on the pin, to seal the orifice when the coil is de-energized.

GAS PRESSURE RATINGS*	ORIFICE SIZE	CV FACTOR	VALVE NUMBER	LIQUID PRESSURE RATINGS*	ORIFICE SIZE	CV FACTOR	VALVE NUMBER
3000	1/32	.022	EH21G7DCCM	3000	1/32	.022	EH21G7DCCM
2500	3/64	.041	EH21H7DCCMG	1500	3/64	.041	EH21H7DCCML
1350	1/16	.061	EH21J7DCCMG	850	1/16	.061	EH21J7DCCML
450	3/32	.084	EH21K7DCCMG	300	3/32	.084	EH21K7DCCML

OPTIONS AVAILABLE: – 2 WAY NORMALLY OPEN HI-PRESSURE VALVE

COIL OPTIONS – see page 79

MOLDED COIL

POTTED COIL & HOUSING

POTTED COIL & HOUSING

HIGH TEMPERATURE MOLDED COIL

MISCELLANEOUS OPTIONS – see page 76

SILVER SHADING RING

ALUMINUM SHADING RING

Note: Availability of certain options or combination of options may vary with quantity of units ordered- Consult representative or factory.



SPECIFICATIONS

MODEL EH21

Two-way normally open valve for high pressure applications.

OPERATING CONDITIONS

Media: Air and other non-corrosive gases, water and oil.

Filtration: Down to 60 microns or less is recommended.

Burst Pressure: 5000 PSI

Maximum Operating Pressure Differential: to 3000 PSI

Valve Temperature Range: Standard Valves - 0°F (- 18°C) to 104°F (40°C) ambient; 0°F (- 18°C) to 150°F (65°C) media. Optional Valves - can tolerate much higher or much lower ambient and media temperatures. Consult factory for specifications.

Listings: Valves are U.L. Listed and CSA Certified for Hazardous Locations—Class I, Div 1, Groups C and D - Class II, Div 1, Groups E, F, and G; Div 2 Groups A,B,C,D,E,F, and G.

ELECTRICAL CHARACTERISTICS

Coil Voltage: 5 to 825 VAC, 50-60 Hz. 1.8 to 265 VDC

Nominal Power: 7.3 watts A.C. 9.5 watts D.C.

Coil Construction: Molded coil and third wire ground (standard)

MECHANICAL CHARACTERISTICS

Body: Stainless Steel

Orifice Diameter: 1/32" - 3/32"

Porting: 1/8" NPT

Housing: Explosion Proof—1/2" NPT conduit

Mounting: Valve must be mounted within 30° of vertical

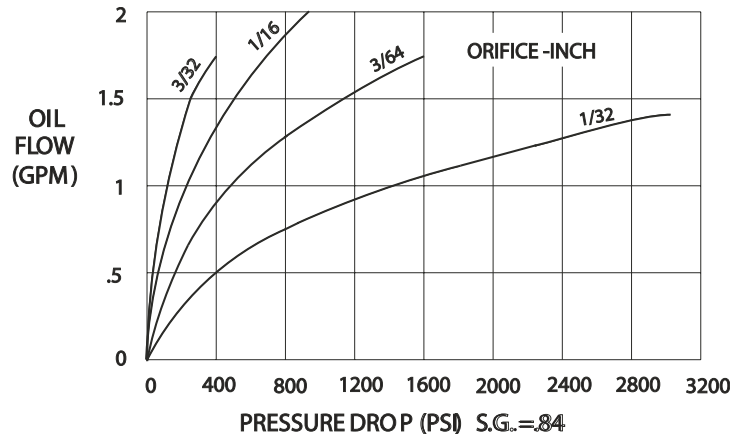
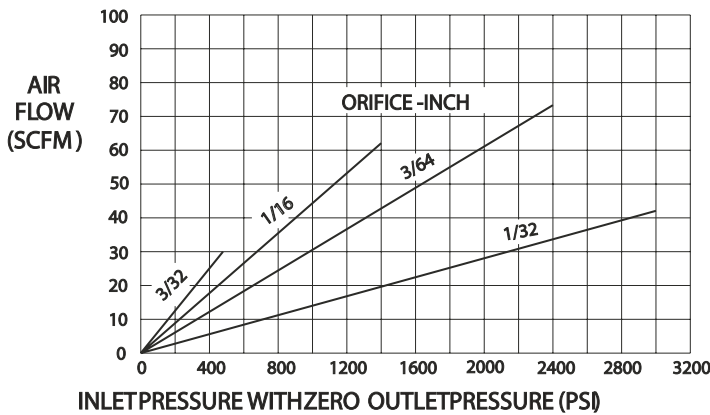
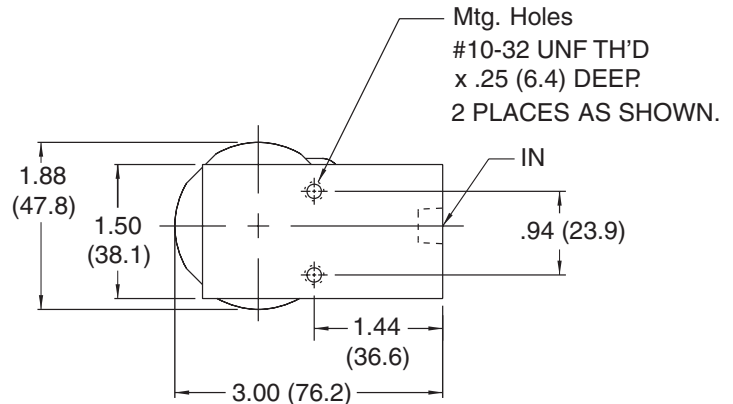
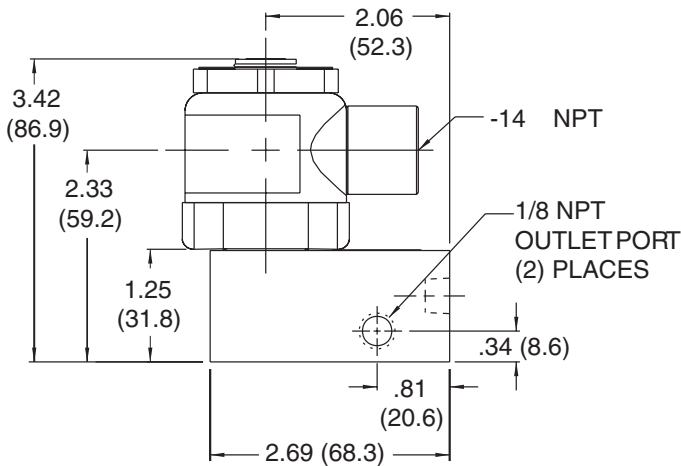

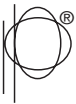

PETER PAUL

SERIES 20 MODEL H22 & EH22 2-WAY NORMALLY CLOSED HIGH PRESSURE IMPACT TYPE SOLENOID VALVE

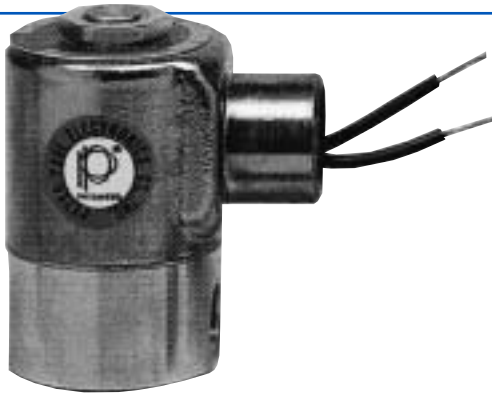

H22



EH22

EXCLUSIVE FEATURES INCLUDE:

A precision stainless steel PLUNGER that supplies the necessary impact force to energize valve.

A Kel-F® PIN† which functions as a sealing element, that is carefully machined for maximum concentricity and fine finish.

The ORIFICE GUIDE is one piece, for near perfect alignment. This means bubble-tight sealing from low pressures right up to maximum pressure rating with the bonus of longer life. The one piece Orifice/Guide can be pressed into almost any standard cavity making it available as an operator for special customer installations.

† Other pin materials available. consult factory

PATENTED

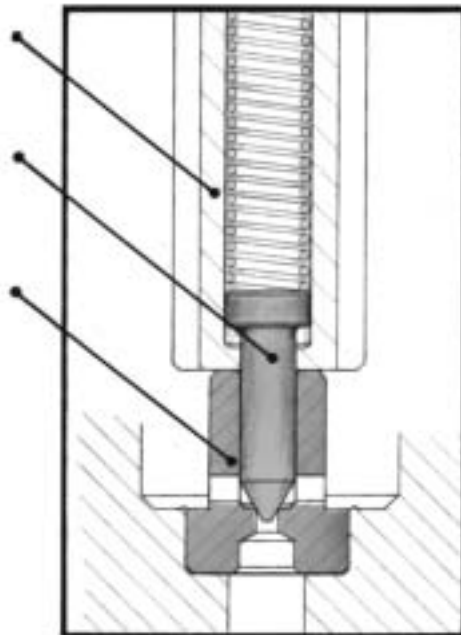

OTHER FEATURES INCLUDE:

Simple construction...

Only 2 moving parts

Available in both standard and explosion proof construction

1/8 or 1/4 NPT ports

PRINCIPLES OF OPERATION

When the valve coil is energized, the plunger is drawn towards the sleeve end stop. The plunger is allowed to accelerate freely for a short distance before it makes contact with the pin shoulder. Upon contact it imparts considerable force on the pin causing it to lift off the seat. A return spring provides the return force, directly on the pin, to seal the orifice when the coil is de-energized.

OPTIONS AVAILABLE: – 2 WAY NORMALLY CLOSED HI-PRESSURE VALVE

HOUSING OPTIONS* see page 78

*STRAIN RELIEF CONNECTOR

*SINGLE AUTOMOTIVE

*DOUBLE AUTOMOTIVE

* "AN" CONNECTOR

MOUNTING BRACKET

COIL OPTIONS – see page 79

MOLDED COIL

POTTED COIL & HOUSING

MISCELLANEOUS OPTIONS – see page 76

HIGH TEMPERATURE MOLDED COIL

SILVER SHADING RING

ALUMINUM SHADING RING

Note: Availability of certain options or combination of options may vary with quantity of units ordered- Consult representative or factory.

*Not available with explosion proof housing

Note: When ordering, add voltage and frequency to complete valve number (Example H22G7DCV—120/60)
To order operator only, add "O" as prefix to valve number (Example OH22GADGV—120/60)

SERIES 20 MODEL H22 2-WAY NORMALLY CLOSED-HIGH PRESSURE									
GAS PRESSURE RATINGS*		ORIFICE SIZE	CV FACTOR	VALVE NUMBER					
AC	DC			GROMMET		CONDUIT		EXPLOSION PROOF	
				1/8 NPT	1/4NPT	1/8 NPT	1/4 NPT	1/8 NPT	1/4 NPT
3000	3000	1/32	.022	H22G7DGV	H22G9DGV	H22G7DCV	H22G9DCV	EH22G7DCCM	EH22G9DCCM
2500	1500	3/64	.041	H22H7DGVG	H22H9DGVG	H22H7DCVG	H22H9DCVG	EH22H7DCCMG	EH22H9DCCMG
1750	500	1/16	.065	H22J7DGVG	H22J9DGVG	H22J7DCVG	H22J9DCVG	EH22J7DCCMG	EH22J9DCCMG
650	100	3/32	.100	H22K7DGVG	H22K9DGVG	H22K7DCVG	H22K9DCVG	EH22K7DCCMG	EH22K9DCCMG

LIQUID PRESSURE RATINGS*		ORIFICE SIZE	CV FACTOR	VALVE NUMBER					
AC	DC			GROMMET		CONDUIT		EXPLOSION PROOF	
				1/8 NPT	1/4NPT	1/8 NPT	1/4 NPT	1/8 NPT	1/4 NPT
3000	3000	1/32	.022	H22G7DGV	H22G9DGV	H22G7DCV	H22G9DCV	EH22G7DCCM	EH22G9DCCM
1500	1500	3/64	.041	H22H7DGV	H22H9DGV	H22H7DCV	H22H9DCV	EH22H7DCCML	EH22H9DCCML
1000	500	1/16	.065	H22J7DGV	H22J9DGV	H22J7DCV	H22J9DCV	EH22J7DCCML	EH22J9DCCML
300	100	3/32	.100	H22K7DGV	H22K9DGV	H22K7DCV	H22K9DCV	EH22K7DCCML	EH22K9DCCML

SPECIFICATIONS

SERIES 20—MODEL H22

Three-way normally closed valve for high pressure applications. Valve must be mounted within 30° of vertical.

OPERATING CONDITIONS

†Media: Air and other non-corrosive gases, water and oil.

Valve Temperature Range: Standard Valve-0°F(-18°C) to 104°F(40°) ambient; 0°F(-18°C) to 150°F(65°C) media. Optional Valves can tolerate much higher or much lower ambient and media temperatures. Consult factory for specifics.

Burst Pressure: 5000 PSI

Maximum Operating Pressure Differential: to 3000 PSI

†To insure trouble free operation, filtration down to 60 microns or less is recommended.

Listings: Valves are U.L. Listed and CSA Certified for Hazardous Locations—Class I, Div 1, Group C and D - Class II, Div 1, Groups E, F, and G; Div 2 Groups A,B,C,D,E,F, and G.

ELECTRICAL CHARACTERISTICS

Coil Voltage: 5 to 825 VAC, 50-60 Hz. 1.8 to 265 VDC

Nominal Power:

H22

EH 22

A.C. 7.7 watts

A.C. 7.3 watts

D.C. 9.5 watts

D.C. 9.5 watts

Coil Construction: Standard valve—molded and non-molded
Explosion Proof valve—molded coil and 3rd wire ground (standard)

Typical Response Time on Air: 4-16 milliseconds

MECHANICAL CHARACTERISTICS

Body: Stainless Steel

Orifice Diameter: 1/32" - 3/32"

Porting: 1/8" and 1/4" NPT

Housing: Standard valve—1/2" NPT conduit and grommet
Explosion Proof valve—1/2" NPT conduit with 3rd Wire Ground (EP only)

STANDARD



GROMMET HOUSING

WT. 1.06 LB.



CONDUIT HOUSING

WT. 1.13 LB.

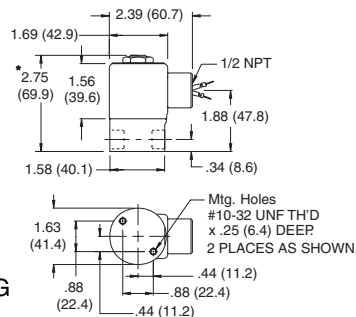

EXPLOSION PROOF

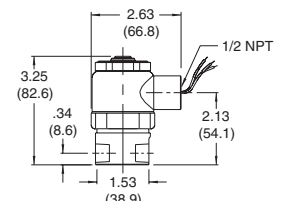

WT. 1.56 LB.

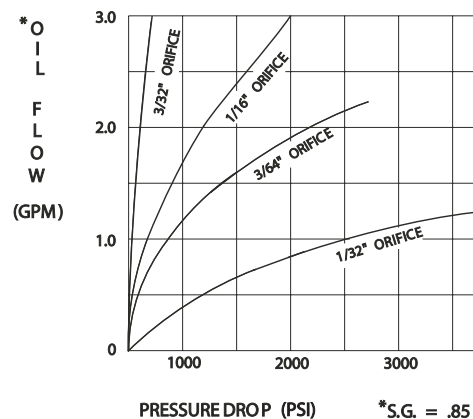
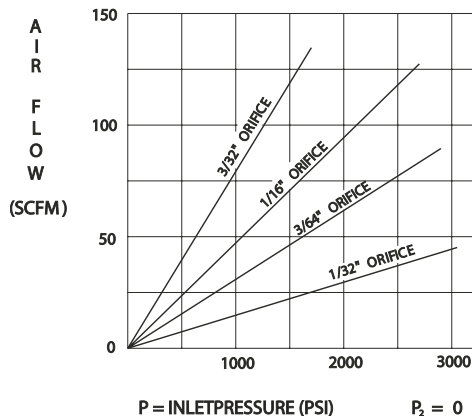
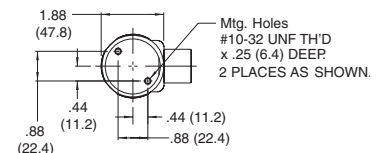

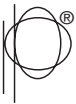

PETER PAUL

SERIES 20 MODEL H23 & EH23 & H24 HIGH PRESSURE IMPACT TYPE DUAL OPERATOR SOLENOID VALVE

3-way media control at super-high pressure ratings



EH23



Series 20-Model H24 with single solenoid

3-Way Normally Open
Coil Voltage: DC Only
CV Factor Inlet: .010
CV Factor Exhaust: .024
Maximum Operating Pressure Differential:
1000 PSI (Gas or Liquid)
Orifice Size: .6 mm x 1/32"

Using the heart of the highly successful model H-22 valve, Peter Paul Electronics introduces a new dual operator valve that allows the same media control as a three way normally closed valve but at much higher pressure ratings than previously available.

To function as a 3-Way NC valve, operators must be alternately energized and de-energized. Pressure applied to "IN" Port must *always* be equal to or greater than the pressure in "CYL" Port

+EXCLUSIVE FEATURES INCLUDE:

- A precision stainless steel PLUNGER that supplies the necessary impact force to energize valve.
- A Kel-F® PIN* which functions as a sealing element, that is carefully machined for maximum concentricity and fine finish.
- The ORIFICE GUIDE is one piece, for near perfect alignment. This means bubble-tight sealing from low pressures right up to maximum pressure* rating with the bonus of longer life.
- All internal connections are contained in the valve body. No need for sleeve adaptors or connecting tubes. All port connections are in the valve body.

* Other pin materials available. consult factory

PATENTED

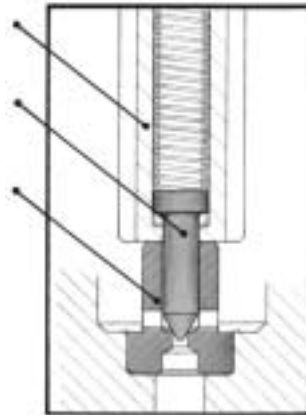

OTHER FEATURES INCLUDE:

- Simple construction...
- Only 2 moving parts per operator
- Available in both standard and explosion proof construction
- 1/4 NPT ports

PRINCIPLES OF OPERATION

When the valve coil is energized, the plunger is drawn towards the sleeve end stop. The plunger is allowed to accelerate freely for a short distance before it makes contact with the pin shoulder. Upon contact it imparts considerable force on the pin causing it to lift off the seat. A return spring provides the return force, directly on the pin, to seal the orifice when the coil is de-energized.

Here is how it's done...

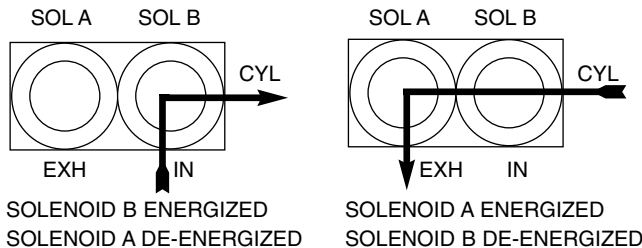

NOTE: ALL PORTS OPEN WHEN BOTH SOLENOIDS ENERGIZED
ALL PORTS CLOSED WHEN BOTH SOLENOIDS DE-ENERGIZED

OPTIONS AVAILABLE: – 3 WAY HI-PRESSURE VALVE

HOUSING OPTIONS see page 78

*STRAIN RELIEF CONNECTOR

* "AN" CONNECTOR

COIL OPTIONS – see page 79

MOLDED COIL

POTTED COIL & HOUSING

HIGH TEMPERATURE MOLDED COIL

MISCELLANEOUS OPTIONS – see page 76

SILVER SHADING RING

ALUMINUM SHADING RING

*Not available with explosion proof housing

MODEL EH23-EXPLOSION PROOF VERSION is U.L. Listed and CSA Certified for hazardous locations—Class I, Groups C & D; Class II, Groups E, F, AND G - Consult factory.

Note: Availability of certain options or combination of options may vary with quantity of units ordered- Consult representative or factory.



GAS PRESSURE RATINGS		ORIFICE		CV	VALVE NUMBER		LIQUID PRESSURE RATINGS		ORIFICE		CV	VALVE NUMBER	
AC	DC	SIZE	FACTOR	STANDARD VALVE	EXP. PROOF VALVE	AC	DC	SIZE	FACTOR	STANDARD VALVE	EXP. PROOF VALVE		
3000	3000	1/32	.022	H23GG19DCV	EH23GG19DCCM	3000	3000	1/32	.022	H23GG19DCV	EH23GG19DCCM		
2500	1500	3/64	.041	H23HH19DCVG	EH23HH19DCCMG	1500	1500	3/64	.050	H23HH19DCVL	EH23HH19DCCML		
1750	500	1/16	.065	H23JJ19DCVG	EH23JJ19DCCMG	1000	500	1/16	.070	H23JJ19DCVL	EH23JJ19DCCML		
650	100	3/32	.100	H23KK19DCVG	EH23KK19DCCMG	300	100	3/32	.130	H23KK19DCVL	EH23KK19DCCML		

†Availability of certain options or combination of options may vary with quantity of units ordered. Consult representative or factory.

Note: When ordering, add voltage and frequency to complete valve number (Example H23GG19DCV—120/60)

SPECIFICATIONS

SERIES 20—MODEL H23

Three-way normally closed valve for high pressure applications. Valve must be mounted within 30° of vertical.

OPERATING CONDITIONS

†**Media:** Air and other non-corrosive gases, water and oil.

Valve Temperature Range: 0°F (-18°C) to a maximum of 221°F (105°C) including coil heat rise, ambient and media temperatures. Other temperature ranges available on request—along with specific application parameter information specified.

Burst Pressure: 5000 PSI

Maximum Operating Pressure Differential: to 3000 PSI

†To insure trouble free operation, filtration down to 60 microns or less is recommended.

Listings: Valves are U.L. Listed and CSA Certified for Hazardous Locations—Class I, Div 1, Group C and D - Class II, Div 1, Groups E, F, and G; Div 2 Groups A,B,C,D,E,F, and G.

ELECTRICAL CHARACTERISTICS

Coil Voltage: 5 to 825 VAC, 50-60 Hz. 1.8 to 265 VDC

Nominal Power: Wattage Per Operator

A.C. 7.3 watts

D.C. 9.5 watts

Coil Construction: Standard Valve—molded and non-molded
Explosion Proof valve—molded

Typical Response Time on Air: 4-16 milliseconds

MECHANICAL CHARACTERISTICS

Body: 300 Series Stainless Steel

†Aluminum Alloy-option available

Orifice Diameter: 1/32" - 3/32"

Porting: 1/4" NPT

Housing: Standard & Explosion Proof valves—1/2" NPT conduit

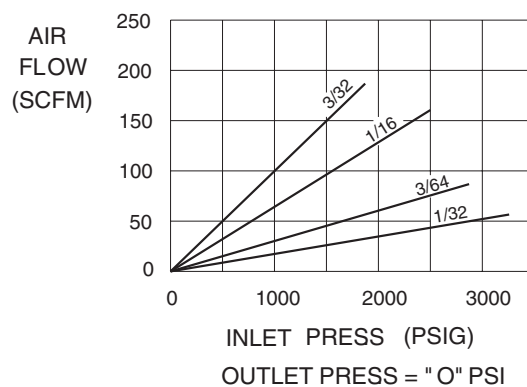
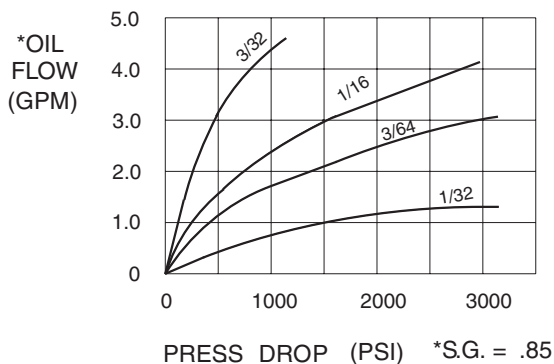
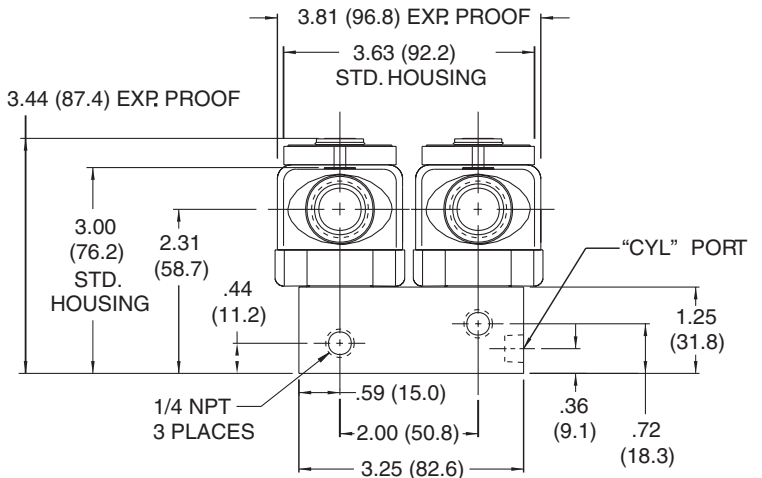
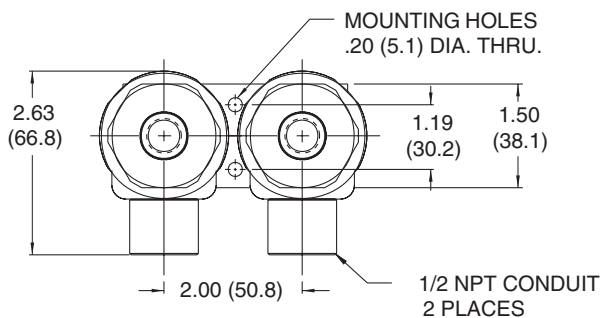

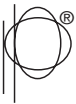

PETER PAUL

SERIES 50 EW (5 WATTS AC & DC) MINIATURE HAZARDOUS LOCATION VALVES!

Meet today's demands for economy of space and energy consumption.

APPLICATION:

Peter Paul developed a UL approved, low watt, miniature hazardous location valve with minimal space and energy requirements in volatile environments. This valve is the smallest hazardous location solenoid, with the best ambient and high temperature ratings on the market. A NEMA 4 rating is standard. The Series 50 EW miniature valve with encapsulated coil also serves as a general purpose valve for pneumatic and hydraulic conditions.

SPECIFICATIONS—

OPERATING CONDITIONS

Media: Air and other fluids, compatible with standard Buna seals. Hot water, steam, gasoline, oils, some hydrolic fluids, and many other media require special seal materials - Consult representative of factory.

Valve Temperature Range: Standard Valves - 0°F (-18°C) to 140°F (60°C) ambient; 0°F (-18°C) to 150°F (60°C) media. Optional Valves - can tolerate much higher or much lower ambient and media temperatures. Consult factory for specifications.

Maximum Operating Pressure Differentials: See catalog listings

Burst Pressure: 5000 PSI

Leakage: Bubble tight for standard valves

Vacuum: To 5 Microns - Consult factory

ELECTRICAL CHARACTERISTICS

Coil Voltage: 24 to 277 VAC 50-60 HZ.-6 to 200 VDC. All standard voltages (U.S. & Export) carried in stock. Special voltages readily produced on order.

Nominal Power: **Series 50**
EW 5.0 watts AC and DC

Coil Construction: Standard, Molded with 24" leads.

Typical Response Time on Air: 4-16 Milliseconds

Operating Speed: Up to 600 CPM

Duty Cycle: Continuous or Intermittent

MECHANICAL CHARACTERISTICS

Material: All interior parts are stainless steel

Orifice Diameter: See catalog listings

Porting: 1/8 NPT

Housing: Encapsulated construction with 1/2 NPT conduit connection and third wire ground.

Listings: Valves are U.L. Listed for Hazardous Locations—Class I, Div 1, Groups A, B, C and D - Class II, Div 1 Groups E, F, and G; Div 2 Groups A, B, C, D, E, F and G. "T" Rating as low as T4

Life expectancy: Millions of cycles, depending on application, lubrication, etc.

Valve Weight: Only .60 lbs average

Repair Packs: Consult Factory

FOR FLOW CHARTS SEE PAGES 95-97

MINIATURE EXPLOSIONPROOF SOLENOID VALVE OPERATORS

A complete line of valve operators for O.E.M. applications are offered for those who wish to incorporate them in their own product line. Full technical information and details are available for Peter Paul.

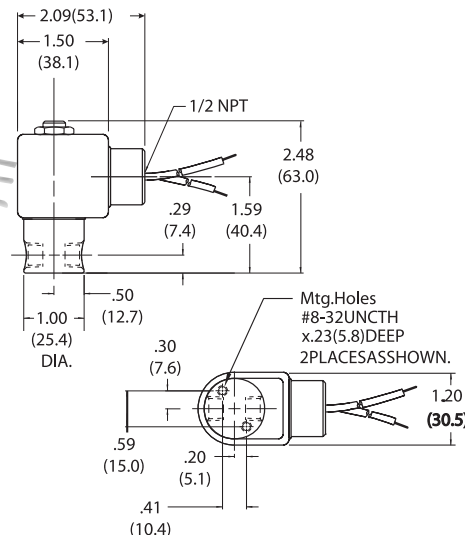

2-Way Normally Closed

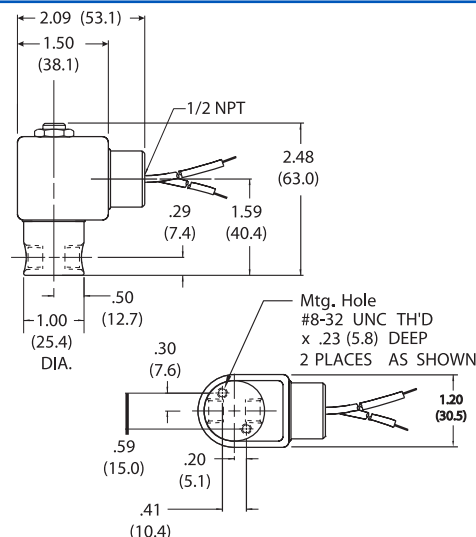

**3-Way Normally Closed
Exhaust to Atmosphere**

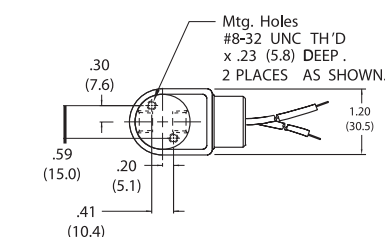
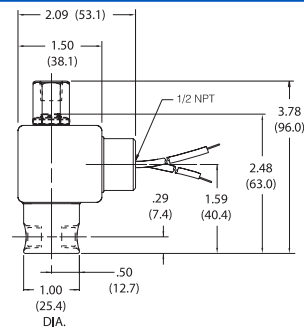

3-Way Styles with Piped Sleeve

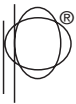

MODEL TYPE	FLOW CONFIGURATION		Valve Number	MAX. OPER. PRESS DIFF.		ORIFICE SIZE		CV FACTOR	
				AC	DC	INLET	EXH.	INLET	EXH.
MODEL EW51 2-Way Normally Open **	DE-ENERGIZED	ENERGIZED	EW51G8XCCP	700	700				.020
			EW51H8XCCP	500	500		1/32		.048
			EW51J8XCCP	200	200		3/64		.075
			EW51V8XCCP	135	135		1/16		.134
			EW51K8XCCP	100	100		5/64		.150
							3/32		
MODEL EW52 2-Way Normally Closed	DE-ENERGIZED	ENERGIZED	EW52G8DCCP	1000	1000	1/32		.022	
			EW52H8DCCP	500	500	3/64		.055	
			EW52J8DCCP	400	250	1/16		.075	
			EW52V8DCCP	200	200	3/64		.134	
			EW52K8DCCP	150	150	3/32		.156	
			EW52N8DCCP	125	75	1/8		.230	
			EW52O8DCCP	50	10	5/32		.292	
MODEL EW53 3-Way Normally Closed ATMOSPHERE EXHAUST	DE-ENERGIZED	ENERGIZED	EW53GG8DCCP	250	250	1/32	1/32	.022	.020
			EW53HH8DCCP	150	150	3/64	3/64	.055	.048
			EW53HJ8DCCP	150	150	3/64	1/16	.055	.075
			EW53JJ8DCCP	100	100	1/16	1/16	.075	.075
			EW53KK8DCCP	50	50	3/32	3/32	.150	.150
MODEL EW53 3-Way Normally Closed WITH PIPED EXHAUST **	DE-ENERGIZED	ENERGIZED	EW53GG8XCCP	250	250	1/32	1/32	.022	.020
			EW53HH8XCCP	150	150	3/64	3/64	.055	.048
			EW53HJ8XCCP	150	150	3/64	1/16	.055	.075
			EW53JJ8XCCP	100	100	1/16	1/16	.075	.075
			EW53KK8XCCP	50	50	3/32	3/32	.150	.150
MODEL EW54 3-Way Normally Open **	DE-ENERGIZED	ENERGIZED	EW54GG8XCCP	200	150	1/32	1/32	.020	.022
			EW54HH8XCCP	125	90	3/64	3/64	.048	.055
			EW54JJ8XCCP	100	60	1/16	1/16	.075	.075
			EW54VV8XCCP	75	40	3/64	3/64	.134	.134
			EW54KK8XCCP	50	25	3/32	3/32	.150	.150
MODEL EW55 3-Way Directional Control **	DE-ENERGIZED	ENERGIZED	EW55GG8XCCP	300	225	1/32*	1/32	.022*	.020
			EW55HH8XCCP	250	80	3/64*	3/64	.055*	.048
			EW55JJ8XCCP	125	40	1/16*	1/16	.075*	.075
			EW55VV8XCCP	70	25	5/64*	5/64	.134*	.134
			EW55KK8XCCP	55	20	3/32*	3/32	.150*	.150
MODEL EW56 3-Way Multi-purpose **	DE-ENERGIZED	ENERGIZED	EW56GG8XCCP	125	100	1/32*	1/32	.022*	.020
			EW56HH8XCCP	100	40	3/64*	3/64	.055*	.048
			EW56JJ8XCCP	65	20	1/16*	1/16	.075*	.075
			EW56VV8XCCP	45	15	5/64*	5/64	.134*	.134
			EW56KK8XCCP	40	10	3/32*	3/32	.150*	.150

*Normally closed orifice

** Pressure rating may change due to the viscosity of the liquid - consult factory for de-rating.

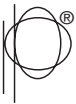

PETER PAUL

SERIES E50 MINIATURE EXPLOSION PROOF VALVES!

Meet today's demands for economy of space and energy consumption. For hazardous locations.

APPLICATION:

General purpose or safety valves for pneumatic and hydraulic applications. The versatility of these valves is increased to include the handling of hot air, hot water, refrigerants and many other media, by the use of different seals.

SPECIFICATIONS—

OPERATING CONDITIONS

Media: Air and other fluids, compatible with standard Buna seals. Hot water, steam, gasoline, oils, some hydraulic fluids, and many other media require special seal materials - Consult representative or factory.

Valve Temperature Range: Standard Valves - 0°F (- 18°C) to 104°F (40°C) ambient; 0°F (- 18°C) to 150°F (65°C) media. Optional Valves - can tolerate much higher or much lower ambient and media temperatures. Consult factory for specifications.

Maximum Operating Pressure Differentials: See catalog listings

Burst Pressure: 5000 PSI

Leakage: Bubble tight for standard valves

Vacuum: To 5 Microns - Consult factory

ELECTRICAL CHARACTERISTICS

Coil Voltage: 5.4 to 575 VAC 50-60 HZ. —3.0 to 300 VDC. All standard voltages (U.S. & Export) carried in stock. Special voltages readily produced on order.

Nominal Power:

D.C. Valves	A.C. VALVES	
	2 WNC Valves	3 Way & 2 WNO Valves
7.2 Watts	4.0 Watts	5.6 Watts

Coil Construction: Standard, Molded with 24" leads. For Non-molded construction consult Factory.

Typical Response Time on Air: 4-16 Milliseconds

Operating Speed: Up to 600 CPM

Duty Cycle: Continuous or Intermittent

MECHANICAL CHARACTERISTICS

Material: All interior parts are stainless steel

Orifice Diameter: See catalog listings

Porting: 1/8 NPT

Housing: Explosionproof construction with 1/2 NPT conduit connection and third wire ground.

Available in stainless steel (consult factory)

Listings: Valves are U.L. Listed and CSA Certified for Hazardous Locations—Class I, Div 1, Group C and D - Class II, Div 1, Groups E, F, and G; Div 2 Groups A,B,C,D,E,F, and G.

Life expectancy: Millions of cycles, depending on application, lubrication, etc.

Valve Weight: Only .65 lbs average

Repair Packs: Consult Factory

OPTIONS: Also available in all stainless steel construction

Metering, bottom orifice or cavity porting, manifold mount, built in muffler, universal mounting bracket, potted coil, Class H molded coil.

FOR FLOW CHARTS SEE PAGES 95-97

MINIATURE EXPLOSION-PROOF SOLENOID VALVE OPERATORS

A complete line of valve operators for O.E.M. applications are offered for those who wish to incorporate them in their own product line. Full technical information and details are available from Peter Paul.

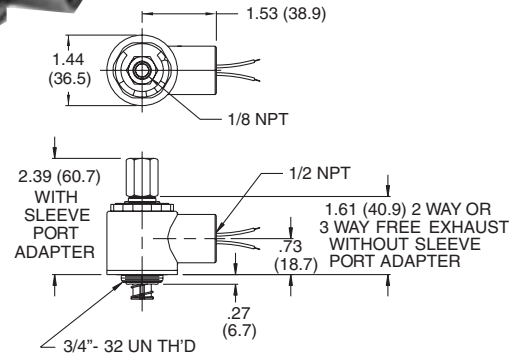

Operator

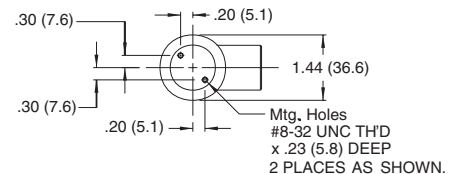
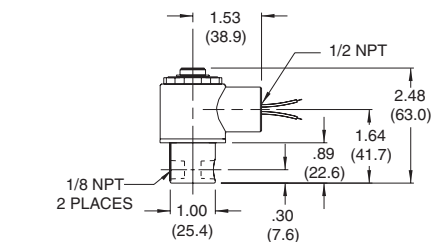

2-Way Normally Closed and 3-Way Normally Closed Exhaust to Atmosphere

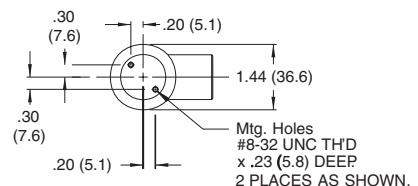
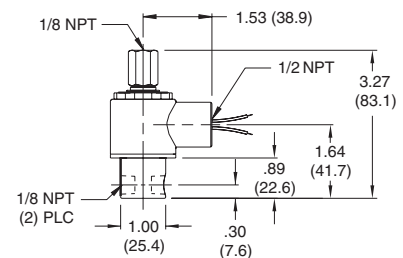

3-Way Normally Closed Piped Exhaust

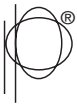

SOLENOID VALVES . . .

MODEL TYPE	FLOW CONFIGURATION	VALVE NO.	MAXIMUM OPERATING PRESSURE DIFFERENTIAL		ORIFICE SIZE		CV FACTOR	
			AC	DC	INLET	EXHAUST	INLET	EXHAUST
MODEL E51 2 Way Normally Open **	 DE-ENERGIZED OUT IN ENERGIZED OUT IN	E51G8XCCM	400	200		1/32		.020
		E51H8XCCM	200	100		3/64		.048
		E51J8XCCM	125	60		1/16		.075
		E51K8XCCM	40	40		3/32		.150
MODEL E52 2 Way Normally Closed	 DE-ENERGIZED OUT IN ENERGIZED OUT IN	E52G8DCCM	500	250	1/32		.022	
		E52H8DCCM	400	150	3/64		.055	
		E52J8DCCM	200	100	1/16		.075	
		E52K8DCCM✓	100	45	3/32		.156	
		E52N8DCCM	75	25	1/8		.230	
MODEL E53 3 Way Normally Closed Exhaust To Atmosphere	 DE-ENERGIZED IN CYL ENERGIZED IN CYL	E53GG8DCCM	200	200	1/32	1/32	.022	.020
		E53HH8DCCM	150	150	3/64	3/64	.055	.048
		E53HJ8DCCM✓	150	150	3/64	1/16	.055	.075
		E53JJ8DCCM	100	100	1/16	1/16	.075	.075
		E53KJ8DCCM	60	60	3/32	1/16	.156	.075
		E53KK8DCCM	50	50	3/32	3/32	.156	.156
		E53NJ8DCCM	30	30	1/8	1/16	.230	.075
		E53NK8DCCM	30	30	1/8	3/32	.230	.156
MODEL E53 3 Way Normally Closed Piped Exhaust **	 DE-ENERGIZED IN CYL ENERGIZED IN CYL	E53GG8XCCM	200	200	1/32	1/32	.022	.020
		E53HH8XCCM	150	150	3/64	3/64	.055	.048
		E53HJ8XCCM✓	150	150	3/64	1/16	.055	.075
		E53JJ8XCCM	100	100	1/16	1/16	.075	.075
		E53KJ8XCCM	60	60	3/32	1/16	.156	.075
		E53KK8XCCM	50	50	3/32	3/32	.156	.156
		E53NJ8XCCM	30	30	1/8	1/16	.230	.075
		E53NK8XCCM	30	30	1/8	3/32	.230	.075
MODEL E54 3 Way Normally Open **	 DE-ENERGIZED IN EXH CYL ENERGIZED IN EXH CYL	E54GG8XCCM	150	150	1/32	1/32	.020	.022
		E54HH8XCCM✓	125	125	3/64	3/64	.048	.055
		E54JJ8XCCM	100	75	1/16	1/16	.075	.075
		E54JK8XCCM	75	45	1/16	3/32	.075	.156
		E54KK8XCCM	50	50	3/32	3/32	.156	.156
		E54JN8XCCM	50	30	1/16	1/8	.075	.230
		E54KN8XCCM	40	25	3/32	1/8	.156	.230
MODEL E55 3 Way Directional Control **	 DE-ENERGIZED N.O. N.C. IN ENERGIZED N.O. N.C. IN	E55GG8XCCM	300	200	1/32*	1/32	.022*	.020
		E55HH8XCCM	200	100	3/64*	3/64	.055*	.048
		E55JJ8XCCM	100	50	1/16*	1/16	.075*	.075
		E55KJ8XCCM✓	75	25	3/32*	1/16	.156*	.075
		E55KK8XCCM	75	40	3/32*	3/32	.156*	.156
		E55NJ8XCCM	65	20	1/8*	1/16	.230*	.075
		E55NK8XCCM	45	20	1/8*	3/32	.230*	.06
MODEL E56 3 Way Multi-Purpose Control **	 DE-ENERGIZED N.O. N.C. COM. IN ENERGIZED N.O. N.C. COM. IN	E56GG8XCCM	125	125	1/32*	1/32	.022*	.020
		E56HHXCCM	100	100	3/64*	3/64	.055*	.048
		E56JJ8XCCM	65	50	1/16*	1/16	.075*	.075
		E56KK8XCCM✓	25	25	3/32*	3/32	.156*	.156

*Normally closed orifice - in these model numbers

For 3/32 sleeve orifice consult factory (not UL or CSA listed)

** Pressure rating may change due to the viscosity of the liquid - consult factory for de-rating.

NOTE: The above checked (✓) Valves are most popular based on sales and likely to be in Distributor stock.

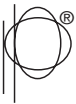

PETER PAUL

SERIES EL 50 MINIATURE EXPLOSION PROOF VALVES (1.8 WATTS AC AND DC) SERIES ELL50 MINIATURE EXPLOSION PROOF VALVES (.85 WATTS DC)

Meet today's demands for economy of space and energy consumption. For hazardous locations.

APPLICATION:

General purpose or safety valves for pneumatic and hydraulic applications. The versatility of these valves is increased to include the handling of hot air, hot water, refrigerants and many other media, by the use of different inserts.

SPECIFICATIONS— OPERATING CONDITIONS

Media: Air and other common gases, common refrigerants except ammonia, city gas supplied by public utilities, Nos. 1 and 2 fuel oils, oils having viscosities not more than 40, SU at 100° F, steam, some hydraulic and water or other aqueous non-flammable liquids. Some media require special seal material - Consult Factory.

Valve Temperature Range: Standard Valves - 0°F (- 18°C) to 104°F (40°C) ambient; 0°F (- 18°C) to 150°F (65°C) media. Optional Valves - can tolerate much higher or much lower ambient and media temperatures. Consult factory for specifications.

Maximum Operating Pressure Differentials: See table listings

Burst Pressure: 4000 PSI

Leakage: Bubble tight for standard valves

Vacuum: To 5 Microns - Consult factory

ELECTRICAL CHARACTERISTICS

Coil Voltage: 5-120 V DC 12-240 V 60HZ. All standard voltages carried in stock. Other voltages readily produced on order.

Nominal Power:

EL50 1.8 watts AC and DC

ELL50 .85 watts DC

Coil Construction: Nonmolded coil, Molded with 24" leads. Molded coil potted inside housing. ALSO MOLDED CLASS H COIL.

Typical Response Time on Air: 4-16 Milliseconds

Operating Speed: Up to 600 CPM

Duty Cycle: Continuous or Intermittent

MECHANICAL CHARACTERISTICS

Material: All interior parts are stainless steel

Orifice Diameter: See table listings

Porting: 1/8 PTF

1/8 NTP - available (consult factory)

Housing: Explosionproof construction with 1/2 NPT conduit connection.

Available in stainless steel (consult factory)

Listings: Valves are U.L. Listed and CSA Certified for Hazardous Locations—Class I, Div 1, Group C and D - Class II, Div 1, Groups E, F, and G; Div 2 Groups A,B,C,D,E,F, and G.

Life expectancy: Millions of cycles, depending on application, lubrication, etc.

Valve Weight: Only .65 lbs average

Repair Packs: Consult Factory

OPTIONS:

Metering, bottom orifice or cavity porting, built in muffler, universal mounting bracket, potted coil, Class H molded coil. Third wire ground available on request.

FOR FLOW CHARTS SEE PAGES 95-97

MINIATURE EXPLOSION-PROOF SOLENOID VALVE OPERATORS

A complete line of valve operators for O.E.M. applications are offered for those who wish to incorporate them in their own product line. Full technical information and details are available from Peter Paul.

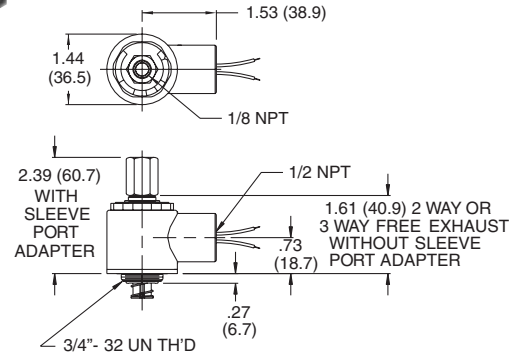

Operator

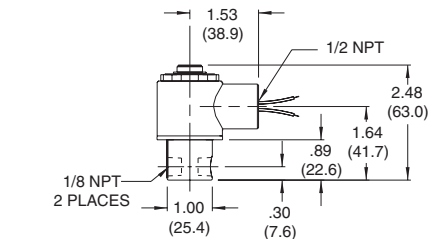

2 Way and 3-Way Normally Closed Exhaust to Atmosphere

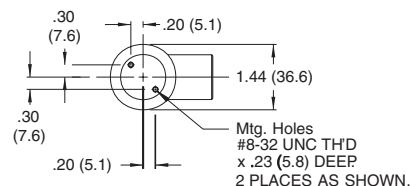
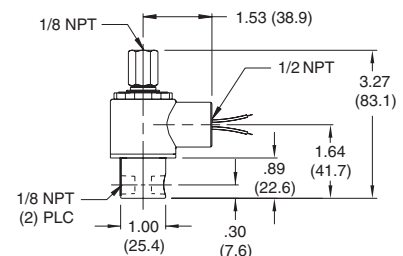
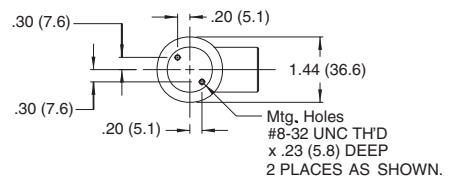

3-Way Normally Closed Piped Exhaust

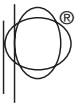

Series EL50

MODEL TYPE	FLOW CONFIGURATION	VALVE NO.	MAXIMUM OPERATING PRESSURE DIFFERENTIAL		ORIFICE SIZE		CV FACTOR	
			AC	DC	INLET	EXHAUST	INLET	EXHAUST
MODEL EL51 2 Way Normally Open **		EL51G8XCM	200	200		1/32		.020
		EL51H8XCM	120	120		3/64		.048
		EL51J8XCM	50	50		1/16		.075
MODEL EL52 2 Way Normally Closed		EL52G8DCM	120	120	1/32		.022	
		EL52H8DCM	80	80	3/64		.055	
		EL52J8DCM	50	50	1/16		.075	
MODEL EL53 3 Way Normally Closed Exhaust To Atmosphere		EL53GG8DCM	120	120	1/32	1/32	.022	.020
		EL53GH8DCM	120	120	1/32	3/64	.022	.048
		EL53HH8DCM	60	60	3/64	3/64	.055	.048
		EL53JJ8DCM	30	30	1/16	1/16	.075	.075
MODEL EL53 3 Way Normally Closed Piped Exhaust **		EL53GG8XCM	120	120	1/32	1/32	.055	.048
		EL53GH8XCM	120	120	1/32	3/64	.022	.048
		EL53HH8XCM	60	60	3/64	3/64	.055	.048
		EL53JJ8XCM	30	30	1/16	1/16	.075	.075

Series ELL50 Explosion Proof Valve Numbers

MODEL TYPE	FLOW CONFIGURATION	VALVE NO.	MAXIMUM OPERATING PRESSURE DIFFERENTIAL	ORIFICE SIZE		CV FACTOR	
			GAS ONLY	INLET	EXHAUST	INLET	EXHAUST
			DC				
MODEL ELL52 2 Way Normally Closed		ELL52G8DCCM	120	1/32		.022	
MODEL ELL53 3 Way Normally Closed Exhaust To Atmosphere		ELL53GG8DCCM	120	1/32	1/32	.022	.022
MODEL ELL53 3 Way Normally Closed Piped Exhaust		ELL53GG8XCCM	120	1/32	1/32	.022	.022

** Pressure rating may change due to the viscosity of the liquid - consult factory for de-rating.

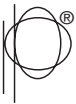

**PETER
PAUL**

SERIES 50 ELW (1.8 WATTS AC & DC) SERIES 50 ELLW (.50 WATTS DC) MINIATURE HAZARDOUS LOCATION VALVES!

Meet today's demands for economy of space and energy consumption.

APPLICATION:

Peter Paul developed a UL approved, low watt, miniature hazardous location valve with minimal space and energy requirements in volatile environments. This valve is the smallest hazardous location solenoid, with the best ambient and high temperature ratings on the market. A NEMA 4 rating is standard. The Series 50 ELW miniature valve with encapsulated coil also serves as a general purpose valve for pneumatic and hydraulic conditions.

SPECIFICATIONS—

OPERATING CONDITIONS

Media: Air and other fluids, compatible with standard Buna seals. Hot water, steam, gasoline, oils, some hydraulic fluids, and many other media require special seal materials - Consult representative of factory.

Valve Temperature Range: Standard Valves - 0°F (-18°C) to 140°F (60°C) ambient; 0°F (-18°C) to 150°F (60°C) media. Optional Valves - can tolerate much higher or much lower ambient and media temperatures. Consult factory for specifications.

Maximum Operating Pressure Differentials: See catalog listings

Burst Pressure: 5000 PSI

Leakage: Bubble tight for standard valves

Vacuum: To 5 Microns - Consult factory

ELECTRICAL CHARACTERISTICS

Coil Voltage: 24 to 277 VAC 50-60 HZ.-6 to 120 VDC. All standard voltages (U.S. & Export) carried in stock. Special voltages readily produced on order.

Nominal Power: **Series 50**

ELW 1.8 watts AC and DC

ELLW .50 watts DC only

Coil Construction: Standard, Molded with 24" leads.

Typical Response Time on Air: 4-16 Milliseconds

Operating Speed: Up to 600 CPM

Duty Cycle: Continuous or Intermittent

MECHANICAL CHARACTERISTICS

Material: All interior parts are stainless steel

Orifice Diameter: See catalog listings

Porting: 1/8 NPT

Housing: Encapsulated construction with 1/2 NPT conduit connection and third wire ground.

Listings: Valves are U.L. Listed for Hazardous Locations—Class I, Div 1, Groups A, B, C and D - Class II, Div 1 Groups E, F, and G; Div 2 Groups A, B, C, D, E, F and G. "T" Rating as low as T5

Life expectancy: Millions of cycles, depending on application, lubrication, etc.

Valve Weight: Only .60 lbs average

Repair Packs: Consult Factory

FOR FLOW CHARTS SEE PAGES 95-97

MINIATURE EXPLOSIONPROOF SOLENOID VALVE OPERATORS

A complete line of valve operators for O.E.M. applications are offered for those who wish to incorporate them in their own product line. Full technical information and details are available from Peter Paul.

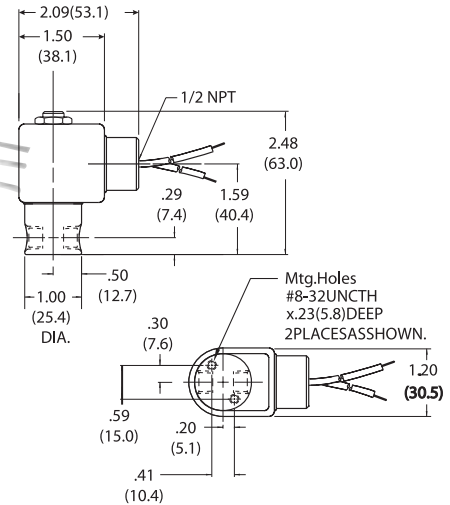

2-Way Normally Closed

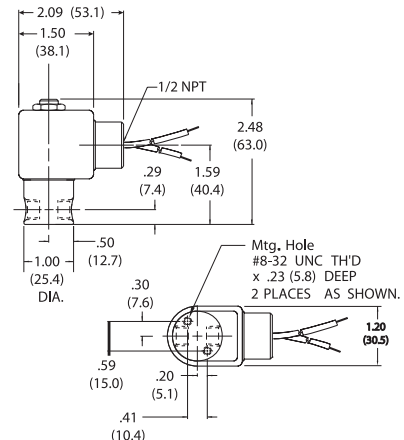

**3-Way Normally Closed
Exhaust to Atmosphere**

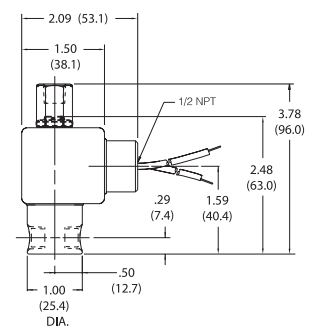

3-Way Normally Closed Piped Exhaust



SOLENOID VALVES . . .

Table A	FLOW CONFIGURATION	VALVE NO.	SUFFIX	ELW 1.8 Watts		MAXIMUM OPERATING PRESSURE DIFFERENTIAL						
				ORIFICE SIZE		Gas		Liquid				
				Inlet	Exhaust	AC	DC	AC	DC			
Model ELW51 2 Way Normally Open	DE-ENERGIZED 	ENERGIZED 	ELW51G8XCCP ELW51H8XCCP (G or L) ELW51J8XCCP (G or L) ELW51V8XCCP (G or L) ELW51K8XCCP (G or L)		G 1/32 H 3/64 J 1/16 V 5/64 K 3/32	300 270 135 70 55	200 120 50 35 30	300 120 40 30 25	200 65 30 20 15			
	Model ELW52 2 Way Normally Closed	DE-ENERGIZED 	ENERGIZED 	ELW52G8DCCP ELW52H8DCCP ELW52J8DCCP ELW52V8DCCP ELW52K8DCCP ELW52N8DCCP ELW52O8DCCP	G 1/32 H 3/64 J 1/16 V 5/64 K 3/32 N 1/8 O 5/32	600 250 150 100 85 50 15	200 80 50 25 20 50 15	600 250 150 100 85 50 15	200 80 50 25 20 50 15			
		Model ELW53 3 Way Normally Closed Exhaust to Atmosphere	DE-ENERGIZED 	ENERGIZED 	ELW53GG8DCCP ELW53GH8DCCP (G or L) ELW53GJ8DCCP (G or L) ELW53GV8DCCP (G or L) ELW53GK8DCCP (G or L) ELW53HH8DCCP (G or L) ELW53HJ8DCCP (G or L) ELW53HV8DCCP (G or L) ELW53HK8DCCP (G or L) ELW53JJ8DCCP (G or L) ELW53JV8DCCP (G or L) ELW53JK8DCCP (G or L) ELW53VV8DCCP (G or L) ELW53VK8DCCP (G or L) ELW53KK8DCCP (G or L)	G 1/32 G 1/32 G 1/32 G 1/32 G 1/32 H 3/64 H 3/64 H 3/64 H 3/64 J 1/16 J 1/16 J 1/16 V 5/64 V 5/64 V 5/64 K 3/32 K 3/32	G 1/32 H 3/64 J 1/16 V 5/64 K 3/32 H 3/64 H 3/64 J 1/16 V 5/64 K 3/32 J 1/16 J 1/16 V 5/64 V 5/64 V 5/64 K 3/32 K 3/32	215 215 135 70 55 120 120 70 55 85 70 50 50 50 35	135 120 50 35 30 70 50 30 30 40 40 30 30 30 30 25 20	215 120 40 30 25 15 120 40 30 30 25 15 20 20 25 15 15	135 65 30 20 15 65 30 20 15 30 20 15 20 20 15 15	
			Model ELW53 3 Way Normally Closed Piped Exhaust	DE-ENERGIZED 	ENERGIZED 	ELW53GG8XCCP ELW53GH8XCCP (G or L) ELW53GJ8XCCP (G or L) ELW53GV8XCCP (G or L) ELW53GK8XCCP (G or L) ELW53HH8XCCP (G or L) ELW53HJ8XCCP (G or L) ELW53HV8XCCP (G or L) ELW53HK8XCCP (G or L) ELW53JJ8XCCP (G or L) ELW53JV8XCCP (G or L) ELW53JK8XCCP (G or L) ELW53VV8XCCP (G or L) ELW53VK8XCCP (G or L) ELW53KK8XCCP (G or L)	G 1/32 G 1/32 G 1/32 G 1/32 G 1/32 H 3/64 H 3/64 H 3/64 H 3/64 J 1/16 J 1/16 J 1/16 V 5/64 V 5/64 V 5/64 K 3/32 K 3/32	G 1/32 H 3/64 J 1/16 V 5/64 K 3/32 H 3/64 H 3/64 J 1/16 V 5/64 K 3/32 J 1/16 J 1/16 V 5/64 V 5/64 V 5/64 K 3/32 K 3/32	215 215 135 70 55 120 120 70 55 85 70 50 50 50 35	135 120 50 35 30 70 50 30 30 40 40 30 30 30 30 25 20	215 120 40 30 25 15 120 40 30 30 25 15 20 20 25 15 15	135 65 30 20 15 65 30 20 15 30 20 15 20 20 15 15

Table B	FLOW CONFIGURATION	VALVE NO.	ELLW .50 Watts		Gas Only
			Inlet	Exhaust	DC
Model ELLW52 2 Way Normally Closed		ELLW52G8DCCP	G 1/32		120
Model ELLW53 3 Way Normally Closed Exhaust to Atmosphere		ELLW53GG8DCCP	G 1/32	G 1/32	120
Model ELLW53 3 Way Normally Closed Piped Exhaust		ELLW53GG8XCCP	G 1/32	G 1/32	120

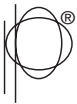

PETER PAUL

SERIES 50 SUPER LOW WATT (SLW) (1.8 WATTS AC & DC) SERIES 50 SUPER LOW LOW WATT (SLLW) (.50 WATTS DC)

Meet today's demands for economy of space and energy consumption.

APPLICATION:

General purpose or safety valves for pneumatic and hydraulic applications. The versatility of these valves is increased to include the handling of hot air, hot water, refrigerants and many other media, by the use of different Seals.

Note: The SLLW Valve is not a safety valve.

SPECIFICATIONS—

OPERATING CONDITIONS

Media: Air and other fluids, compatible with standard Buna seals. Hot water, steam, gasoline, oils, some hydraulic fluids, and many other media require special seal materials - Consult representative of factory.

Valve Temperature Range: Standard Valves - 0°F (- 18°C) to 140°F (60°C) ambient; 0°F (- 18°C) to 150°F (65°C) media. Optional Valves - can tolerate much higher or much lower ambient and media temperatures. Consult factory for specifications.

Maximum Operating Pressure Differentials: See catalog listings

Burst Pressure: 5000 PSI

Leakage: Bubble tight for standard valves

Vacuum: To 5 Microns - Consult factory

ELECTRICAL CHARACTERISTICS

Coil Voltage: 24 to 277 VAC 50-60 HZ.—6 to 120 VDC. All standard voltages (U.S. & Export) carried in stock. Special voltages readily produced on order.

Nominal Power: **Series 50**

SLW 1.8 watts AC and DC

SLLW .50 watts DC only

Coil Construction: Standard, Molded with 24" leads.

Typical Response Time on Air: 4-16 Milliseconds

Operating Speed: Up to 600 CPM

Duty Cycle: Continuous or Intermittent

MECHANICAL CHARACTERISTICS

Material: All interior parts are stainless steel

Orifice Diameter: See catalog listings

Porting: 1/8 NPT

Housing: 1/2 NPT conduit connection and third wire ground.

Life expectancy: Millions of cycles, depending on application, lubrication, etc.

Valve Weight: Only .60 lbs average

OPTIONS: Metering, bottom orifice or cavity porting, manifold mount, built in muffler, universal mounting bracket, potted coil.

FOR FLOW CHARTS SEE PAGES 95-97

SOLENOID VALVE OPERATORS

A complete line of valve operators for O.E.M. applications are offered for those who wish to incorporate them in their own product line. Full technical information and details are available from Peter Paul.

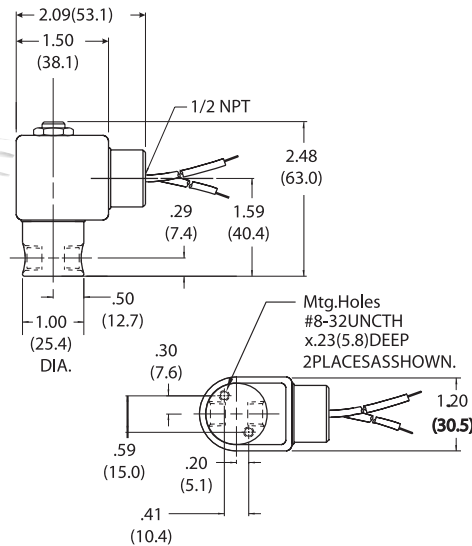
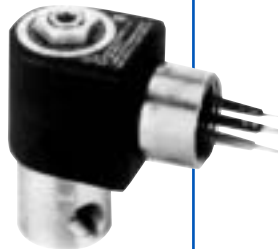

2-Way Normally Closed

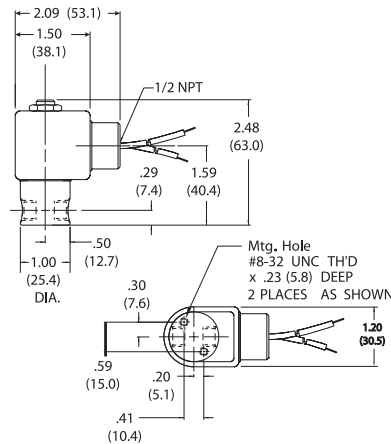

3-Way Normally Closed Exhaust to Atmosphere

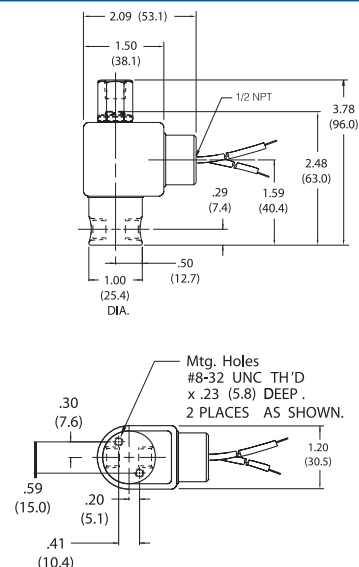

3-Way Normally Closed Piped Exhaust



SOLENOID VALVES . . .

Table A	FLOW CONFIGURATION	VALVE NO.	SUFFIX	SLW 1.8 Watts		MAXIMUM OPERATING PRESSURE DIFFERENTIAL			
				ORIFICE SIZE		Gas		Liquid	
				Inlet	Exhaust	AC	DC	AC	DC
Model SLW51 2 Way Normally Open		SLW51G8XCCP			G 1/32	300	200	300	200
		SLW51H8XCCP (G or L)		H 3/64	270	120	120	65	
		SLW51J8XCCP (G or L)		J 1/16	135	50	40	30	
		SLW51V8XCCP (G or L)		V 5/64	70	35	30	20	
		SLW51K8XCCP (G or L)		K 3/32	55	30	25	15	
Model SLW52 2 Way Normally Closed		SLW52G8DCCP		G 1/32	600	200	600	200	
		SLW52H8DCCP		H 3/64	250	80	250	80	
		SLW52J8DCCP		J 1/16	150	50	150	50	
		SLW52V8DCCP		V 5/64	100	25	100	25	
		SLW52K8DCCP		K 3/32	85	20	85	20	
		SLW52N8DCCP		N 1/8	50		50		
		SLW52O8DCCP		O 5/32	15		15		
Model SLW53 3 Way Normally Closed Exhaust to Atmosphere		SLW53GG8DCCP		G 1/32	G 1/32	215	135	215	135
		SLW53GH8DCCP (G or L)		G 1/32	H 3/64	215	120	120	65
		SLW53GJ8DCCP (G or L)		G 1/32	J 1/16	135	50	40	30
		SLW53GV8DCCP (G or L)		G 1/32	V 5/64	70	35	30	20
		SLW53GK8DCCP (G or L)		G 1/32	K 3/32	55	30	25	15
		SLW53HH8DCCP (G or L)		H 3/64	H 3/64	120	70	120	65
		SLW53HJ8DCCP (G or L)		H 3/64	J 1/16	120	50	40	30
		SLW53HV8DCCP (G or L)		H 3/64	V 5/64	70	35	30	20
		SLW53HK8DCCP (G or L)		H 3/64	K 3/32	55	30	25	15
		SLW53JJ8DCCP (G or L)		J 1/16	J 1/16	85	40	40	30
		SLW53JV8DCCP (G or L)		J 1/16	V 5/64	70	35	30	20
		SLW53JK8DCCP (G or L)		J 1/16	K 3/32	55	30	25	15
		SLW53VV8DCCP (G or L)		V 5/64	V 5/64	50	30	30	20
		SLW53VK8DCCP (G or L)		V 5/64	K 3/32	50	30	25	15
		SLW53KK8DCCP (G or L)		K 3/32	K 3/32	35	20	25	15
Model SLW53 3 Way Normally Closed Piped Exhaust		SLW53GG8XCCP		G 1/32	G 1/32	215	135	215	135
		SLW53GH8XCCP (G or L)		G 1/32	H 3/64	215	120	120	65
		SLW53GJ8XCCP (G or L)		G 1/32	J 1/16	135	50	40	30
		SLW53GV8XCCP (G or L)		G 1/32	V 5/64	70	35	30	20
		SLW53GK8XCCP (G or L)		G 1/32	K 3/32	55	30	25	15
		SLW53HH8XCCP (G or L)		H 3/64	H 3/64	120	70	120	65
		SLW53HJ8XCCP (G or L)		H 3/64	J 1/16	120	50	40	30
		SLW53HV8XCCP (G or L)		H 3/64	V 5/64	70	35	30	20
		SLW53HK8XCCP (G or L)		H 3/64	K 3/32	55	30	25	15
		SLW53JJ8XCCP (G or L)		J 1/16	J 1/16	85	40	40	30
		SLW53JV8XCCP (G or L)		J 1/16	V 5/64	70	35	30	20
		SLW53JK8XCCP (G or L)		J 1/16	K 3/32	55	30	25	15
		SLW53VV8XCCP (G or L)		V 5/64	V 5/64	50	30	30	20
		SLW53VK8XCCP (G or L)		V 5/64	K 3/32	50	30	25	15
		SLW53KK8XCCP (G or L)		K 3/32	K 3/32	35	20	25	15

Table B	FLOW CONFIGURATION	VALVE NO.	SLLW .50 Watts		Gas Only
			Inlet	Exhaust	DC
Model SLLW52 2 Way Normally Closed		SLLW52G8DCCP	G 1/32		120
Model SLLW53 3 Way Normally Closed Exhaust to Atmosphere		SLLW53GG8DCCP	G 1/32	G 1/32	120
Model SLLW53 3 Way Normally Closed Piped Exhaust		SLLW53GG8XCCP	G 1/32	G 1/32	120

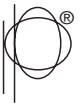

PETER PAUL

SERIES 50 LOW WATT (LW 2.5 WATTS AC AND DC) SERIES 50 LOW LOW WATT (LLW 0.65 WATTS DC)

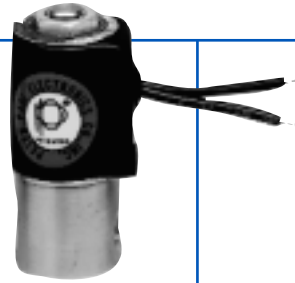

APPLICATION:

General purpose or safety valves for pneumatic and hydraulic applications. The versatility of these valves is increased to include the handling of hot air, hot water, refrigerants and many other media, by the use of different Seals.

Note: The LLW Valve is not a safety valve.

SPECIFICATIONS—

OPERATING CONDITIONS

Media: Air and other fluids, compatible with standard Buna seals. Hot water, steam, gasoline, oils, some hydraulic fluids, and many other media require special seal materials - Consult representative of factory.

Valve Temperature Range: Standard Valves - 0°F (-18°C) to 104°F (40°C) ambient; 0°F (-18°C) to 150°F (65°C) media. Optional Valves - can tolerate much higher or much lower ambient and media temperatures. Consult factory for specifications.

Maximum Operating Pressure Differentials: See catalog listings

Burst Pressure: 5000 PSI

Leakage: Bubble tight for standard valves

Vacuum: To 5 Microns - Consult factory

ELECTRICAL CHARACTERISTICS

Coil Voltage: 24 to 277 VAC 50-60 HZ.— 6 to 120 VDC. All standard voltages (U.S. & Export) carried in stock. Special voltages readily produced on order.

Nominal Power: **Series 50**

LW 2.5 watts AC and DC

LLW 0.65 watts DC only

Coil Construction: Standard, Molded with 24" leads. For Non-molded construction consult Factory.

Typical Response Time on Air: 4-16 Milliseconds

Operating Speed: Up to 600 CPM

Duty Cycle: Continuous or Intermittent

MECHANICAL CHARACTERISTICS

Material: All interior parts are stainless steel

Orifice Diameter: See catalog listings

Porting: 1/8, NPT

Housing: Grommet & 1/2 NPT conduit - many options available.

Life expectancy: Millions of cycles, depending on application, lubrication, etc.

Valve Weight: Only .40 lbs average

OPTIONS: Metering, bottom orifice or cavity porting, manifold mount, built in muffler, universal mounting bracket, potted coil.

FOR FLOW CHARTS SEE PAGES 95-97

SOLENOID VALVE OPERATORS

A complete line of valve operators for O.E.M. applications are offered for those who wish to incorporate them in their own product line. Full technical information and details are available from Peter Paul.

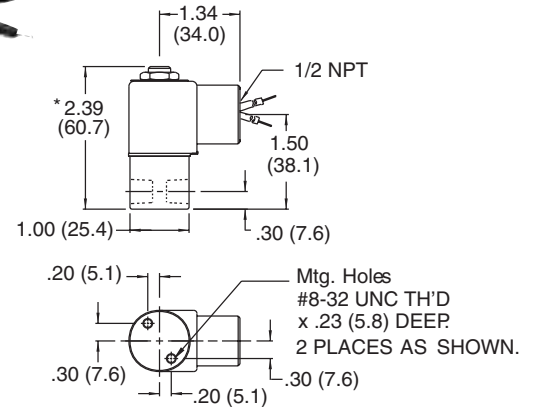

*ADD .232 (5.9) FOR SPADE TERMINAL COIL OPTION

2-Way Normally Closed

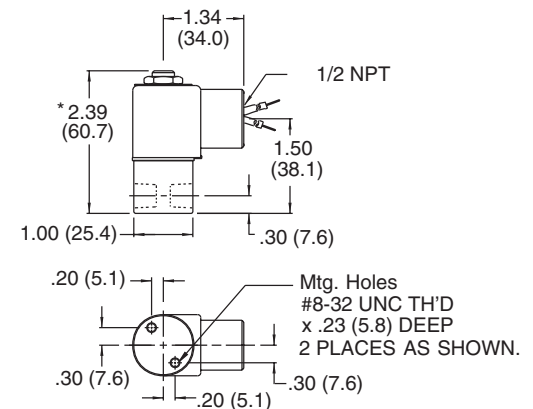

*ADD .232 (5.9) FOR SPADE TERMINAL COIL OPTION

3-Way Normally Closed Exhaust to Atmosphere

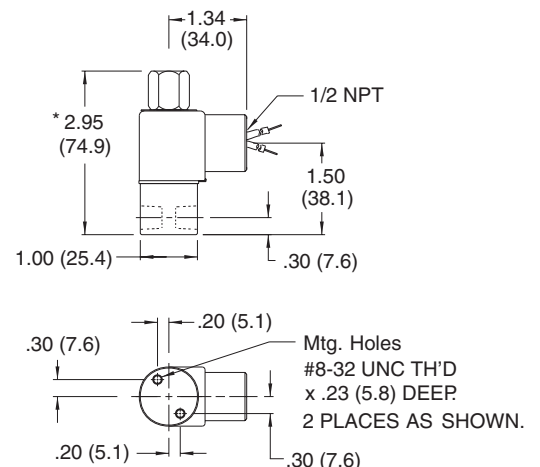

*ADD .232 (5.9) FOR SPADE TERMINAL COIL OPTION

3-Way Normally Closed Piped Exhaust



PETER PAUL

SOLENOID VALVES . . .

Table A	FLOW CONFIGURATION		VALVE NO.	SUFFIX	LW 2.5 Watts		MAXIMUM OPERATING PRESSURE DIFFERENTIAL			
					ORIFICE SIZE		Gas		Liquid	
					Inlet	Exhaust	AC	DC	AC	DC
Model LW51 2 Way Normally Open	DE-ENERGIZED 	ENERGIZED 	LW51G8XGB		G 1/32	300	200	300	200	
			LW51H8XGB (G or L)		H 3/64	270	120	120	65	
			LW51J8XGB (G or L)		J 1/16	135	50	40	30	
			LW51V8XGB (G or L)		V 5/64	70	35	30	20	
			LW51K8XGB (G or L)		K 3/32	55	30	25	15	
Model LW52 2 Way Normally Closed	DE-ENERGIZED 	ENERGIZED 	LW52G8DGB		G 1/32	600	200	600	200	
			LW52H8DGB		H 3/64	250	80	250	80	
			LW52J8DGB		J 1/16	150	50	150	50	
			LW52V8DGB		V 5/64	100	25	100	25	
			LW52K8DGB		K 3/32	85	20	85	20	
			LW52N8DGB		N 1/8	50		50		
			LW52O8DGB		O 5/32	15		15		
Model LW53 3 Way Normally Closed Exhaust to Atmosphere	DE-ENERGIZED 	ENERGIZED 	LW53G8DGB		G 1/32	215	135	215	135	
			LW53GH8DGB (G or L)		G 1/32	215	120	120	65	
			LW53GJ8DGB (G or L)		G 1/32	135	50	40	30	
			LW53GV8DGB (G or L)		G 1/32	70	35	30	20	
			LW53GK8DGB (G or L)		G 1/32	55	30	25	15	
			LW53HH8DGB (G or L)		H 3/64	120	70	120	65	
			LW53HJ8DGB (G or L)		H 3/64	120	50	40	30	
			LW53HV8DGB (G or L)		H 3/64	70	35	30	20	
			LW53HK8DGB (G or L)		H 3/64	55	30	25	15	
			LW53JJ8DGB (G or L)		J 1/16	85	40	40	30	
			LW53JV8DGB (G or L)		J 1/16	70	35	30	20	
			LW53JK8DGB (G or L)		J 1/16	55	30	25	15	
			LW53VV8DGB (G or L)		V 5/64	50	30	30	20	
			LW53VK8DGB (G or L)		V 5/64	50	30	25	15	
			LW53KK8DGB (G or L)		K 3/32	35	20	25	15	
Model LW53 3 Way Normally Closed Piped Exhaust	DE-ENERGIZED 	ENERGIZED 	LW53G8XGB		G 1/32	215	135	215	135	
			LW53GH8XGB (G or L)		G 1/32	215	120	120	65	
			LW53GJ8XGB (G or L)		G 1/32	135	50	40	30	
			LW53GV8XGB (G or L)		G 1/32	70	35	30	20	
			LW53GK8XGB (G or L)		G 1/32	55	30	25	15	
			LW53HH8XGB (G or L)		H 3/64	120	70	120	65	
			LW53HJ8XGB (G or L)		H 3/64	120	50	40	30	
			LW53HV8XGB (G or L)		H 3/64	10	35	30	20	
			LW53HK8XGB (G or L)		H 3/64	55	30	25	15	
			LW53JJ8XGB (G or L)		J 1/16	85	40	40	30	
			LW53JV8XGB (G or L)		J 1/16	70	35	30	20	
			LW53JK8XGB (G or L)		J 1/16	55	30	25	15	
			LW53VV8XGB (G or L)		V 5/64	50	30	30	20	
			LW53VK8XGB (G or L)		V 5/64	50	30	25	15	
			LW53KK8XGB (G or L)		K 3/32	35	20	25	15	

Table B	FLOW CONFIGURATION	VALVE NO.	LLW .65 Watts		Gas Only
			Inlet	Exhaust	DC
Model LLW52 2 Way Normally Closed		LLW52G8DGB	G 1/32		120
Model LLW53 3 Way Normally Closed Exhaust to Atmosphere		LLW53GG8DGB	G 1/32	G 1/32	120
Model LLW53 3 Way Normally Closed Piped Exhaust		LLW53GG8XGB	G 1/32	G 1/32	120



PETER PAUL

SERIES S58 Uprated Pressure Sub-Miniature Valves (3.5 watts)

Meet today's demands for economy of space and energy consumption.

APPLICATION:

The Series S58 can be easily interfaced with circuit boards and miniaturized components. The versatility is for connecting electronic signals to pneumatic outputs. The small size is ideal for stand alone (with #10-32 ports) or multiple valves mounted on one manifold. May be used to "pilot" larger valves. These valves are ideal for micro electronic production equipment and medical or chemical analytical applications and can operate directly from most programmable controllers.

SPECIFICATIONS—

OPERATING CONDITIONS

Media: Air and other common gasses - filtration recommended - 30 microns or less.

Valve Temperature Range: Standard Valves - 5°F (-15°C) to 122° F (50° C) ambient; media. Optional valves.

Maximum Operating Pressure Differentials: See catalog listings

Burst Pressure: 1500 PSI

Leakage: Bubble tight for standard valves

Vacuum: To 5 Microns - Consult factory

Coil Voltage: 6 to 220 VAC 50-60 HZ.— 2 to 150 VDC. All standard voltages (U.S. & Export) carried in stock. Special voltages readily produced on order.

ELECTRICAL CHARACTERISTICS

Nominal Power:	Series	Watts
	S58	3.5

Coil Construction: Molded

Typical Response Time on Air: AC - 3 TO 9 ms. DC - 9 ms.

Duty Cycle: Continuous

MECHANICAL CHARACTERISTICS

Material: Moving parts - stainless steel
Body - stainless steel or brass
Seals - Nitrile (Buna N) Standard. FKM EPDM ® Optional.

Orifice Diameter: See catalog listings

Porting: 10-32 Thd., stud mount

Housing: Metal Housing with flying leads

Life expectancy: Millions of cycles, depending on application, lubrication, etc.

Valve Weight: 2 3/4 oz

Repair Packs: Consult factory

Options: **Stainless Steel or Brass Body**
Stainless Steel or Brass 10-32 Thd. Stud Mount.

FOR FLOW CHARTS SEE PAGES 95-97

For numbering system chart see page 105

MINIATURE SOLENOID VALVE OPERATORS

A complete line of valve operators for O.E.M. applications are offered for those who wish to incorporate them in their own product line. Full technical information and details are available from Peter Paul.

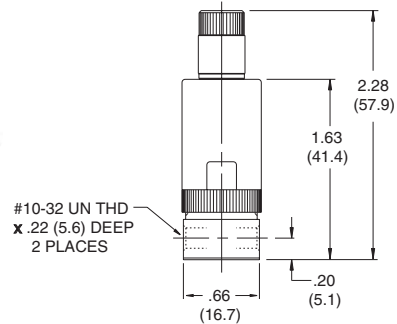

2-Way Normally Closed

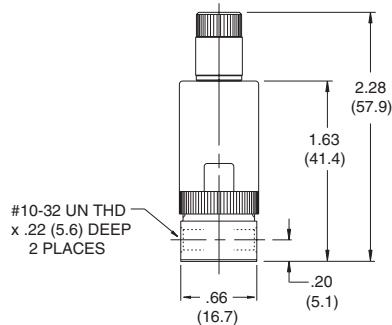
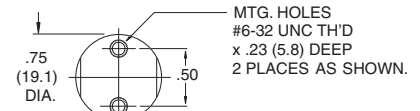

3-Way Normally Closed Exhaust to Atmosphere

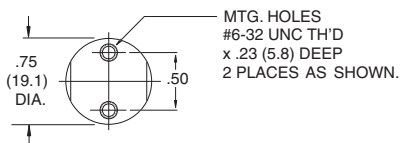
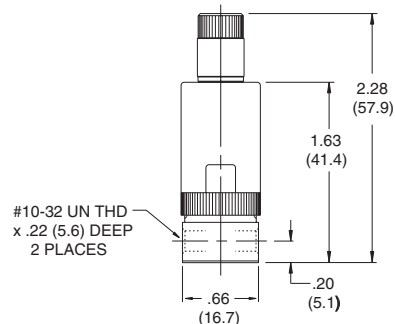
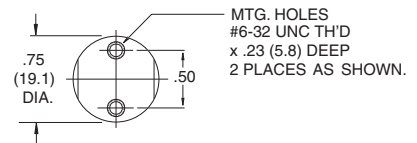

3-Way Normally Closed Piped Exhaust

SOLENOID VALVES . . .

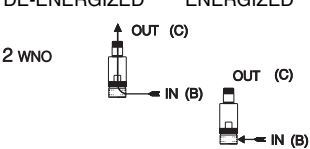
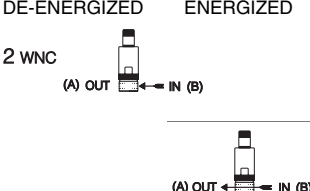
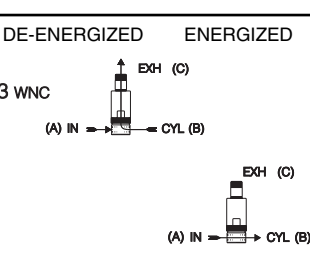
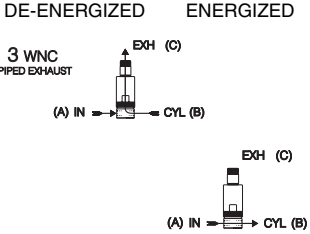
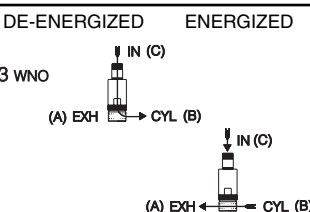
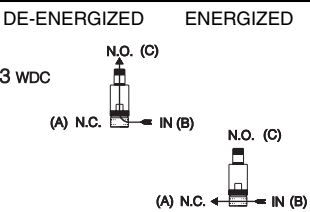
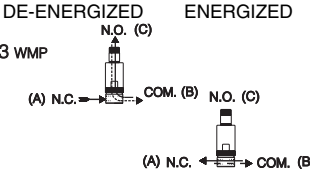
Model Type	FLOW CONFIGURATION	Maximum Operations Pressure Differential		Orifice Size		CV Factor		Lead Wire Unit
		AC	DC	Inlet	Exhaust	Inlet	Exhaust	
Series 58 Model S581 2 Way Normally Open	DE-ENERGIZED ENERGIZED 2 WNO 		500		.6 MM		0.010	S581A21PG S581F21PG S581M21PG S581W21PG
			500		.8 MM		0.020	
			150		1.0 MM		0.030	
			150		1.2 MM		0.040	
Series 58 Model S582 2 Way Normally Closed	DE-ENERGIZED ENERGIZED 2 WNC 		500		.6 MM		0.010	S582A21DG S582F21DG S582M21DG S582W21DG S582Y21DG S582J21DG
			500		.8 MM		0.020	
			350		1.0 MM		0.030	
			250		1.2 MM		0.034	
			200		1.4 MM		0.054	
			150		1.6 MM		0.064	
Series 58 Model S583 3 Way Normally Closed Exhaust to Atmosphere	DE-ENERGIZED ENERGIZED 3 WNC 	300	380	.6 MM	.6 MM	0.010	0.010	S583AA21DG S583AF21DG S583FF21DG S583FM21DG S583MM21DG S583MW21DG S583WW21DG S583YW21DG S583JW21DG
		300	380	.6 MM	.8 MM	0.010	0.020	
		250	310	.8 MM	.8 MM	0.020	0.020	
		145	150	.8 MM	1.0 MM	0.020	0.030	
		100	150	1.0 MM	1.0 MM	0.030	0.030	
		100	150	1.0 MM	1.2 MM	0.030	0.034	
		100	150	1.2 MM	1.2 MM	0.034	0.034	
		100	150	1.4 MM	1.2 MM	0.054	0.034	
		100	150	1.6 MM	1.2 MM	0.060	0.034	
Series 58 Model S583 3 Way Normally Closed Piped Exhaust	DE-ENERGIZED ENERGIZED 3 WNC PIPED EXHAUST 	300	380	.6 MM	.6 MM	0.010	0.010	S583AA21PG S583AF21PG S583FF21PG S583FM21PG S583MM21PG S583MW21PG S583WW21PG S583YW21PG S583JW21PG
		300	380	.6 MM	.8 MM	0.010	0.020	
		250	310	.8 MM	.8 MM	0.020	0.020	
		150	150	.8 MM	1.0 MM	0.020	0.030	
		145	150	1.0 MM	1.0 MM	0.030	0.030	
		100	150	1.0 MM	1.2 MM	0.030	0.034	
		100	150	1.2 MM	1.2 MM	0.034	0.034	
		100	150	1.4 MM	1.2 MM	0.054	0.034	
100	150	1.6 MM	1.2 MM	0.060	0.034			
Series 58 Model S584 3 Way Normally Open	DE-ENERGIZED ENERGIZED 3 WNO 		145	.6 MM	.6 MM	0.010	0.010	S584AA21PG S584FF21PG S584MM21PG S584WW21PG S584WY21PG S584WJ21PG
			100	.8 MM	.8 MM	0.020	0.020	
			65	1.0 MM	1.0 MM	0.030	0.030	
			50	1.2 MM	1.2 MM	0.034	0.034	
			50	1.2 MM	1.4 MM	0.054	0.054	
			50	1.2 MM	1.6 MM	0.060	0.060	
Series 58 Model S585 3 Way Directional Control	DE-ENERGIZED ENERGIZED 3 WDC 		350	.6 MM*	.6 MM	0.010	0.010	S585AA21PG S585FF21PG S585MM21PG S585WW21PG S585YW21PG S585JW21PG
			200	.8 MM*	.8 MM	0.020	0.020	
			150	1.0 MM*	1.0 MM	0.030	0.030	
			135	1.2 MM*	1.2 MM	0.034	0.034	
			75	1.4 MM*	1.2 MM	0.054	0.034	
			70	1.6 MM*	1.2 MM	0.060	0.034	
Series 58 Model S586 3 Way Multipurpose	DE-ENERGIZED ENERGIZED 3 WMP 		145	.6 MM*	.6 MM	0.010	0.010	S586AA21PG S586FF21PG S586MM21PG S586WW21PG
			90	.8 MM*	.8 MM	0.020	0.020	
			55	1.0 MM*	1.0 MM	0.030	0.030	
			23	1.2 MM*	1.2 MM	0.034	0.034	

*Normally closed port

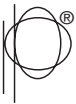

PETER PAUL

SERIES 58 Low Watt Sub-Miniature Valves (3.5 WATTS) SERIES L58 Low Watt Sub-Miniature Valves (0.9 WATTS)

Meet today's demands for economy of space and energy consumption.

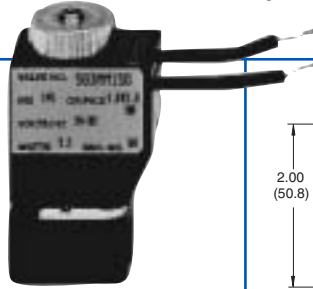

APPLICATION:

The Series 58 can be easily interfaced with circuit boards and miniaturized components. The versatility is for connecting electronic signals to pneumatic outputs. The small size is ideal for stand alone (with #10-32 ports) or multiple valves mounted on one manifold. May be used to "pilot" larger valves. These valves are ideal for micro electronic production equipment and medical or chemical analytical applications and can operate directly from most programmable controllers.

SPECIFICATIONS—

OPERATING CONDITIONS

Media: Air and other common gasses - filtration recommended 30 microns or less.

Valve Temperature Range: Standard Valves - 5°F (-15°C) to 122° F (50° C) ambient; media.

Maximum Operating Pressure Differentials: See catalog listings

Burst Pressure: 1500 PSI

Leakage: Bubble tight for standard valves

Vacuum: To 5 Microns - Consult factory

Coil Voltage: 6 to 220 VAC 50-60 Hz. - 2 to 150V DC. All standard voltages (U.S. & Export) carried in stock. Special voltages readily produced on order.

ELECTRICAL CHARACTERISTICS

Nominal Power:	Series	Watts
Table A	58	3.5
Table B	L58	0.9

Coil Construction: Molded

Typical Response Time on Air: AC - 3 TO 9 ms. DC - 9 ms.

Duty Cycle: Continuous or intermittent

MECHANICAL CHARACTERISTICS

Material: Moving parts - stainless steel
Body - Plastic
Seals - Nitrile (Buna N) Standard. FKM or EPDM © Optional.

Orifice Diameter: See catalog listings

Porting: 10-32 Thd., Stud Mount, Manifold Mount

Life expectancy: Millions of cycles, depending on application, lubrication, etc.

Valve Weight: Approximately 2 oz.

Repair Packs: Consult factory.

Options: Stainless Steel or Brass Body
Stainless Steel or Brass 10-32 Thd. Stud Mount

FOR FLOW CHARTS SEE PAGES 95-97

For Numbering system chart see page 105

MINIATURE SOLENOID VALVE OPERATORS

A complete line of valve operators for O.E.M. applications are offered for those who wish to incorporate them in their own product line. Full technical information and details are available from Peter Paul.

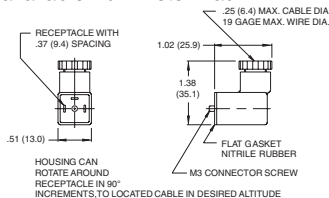

With European Style Micro DIN Connector Plug number 58-19005

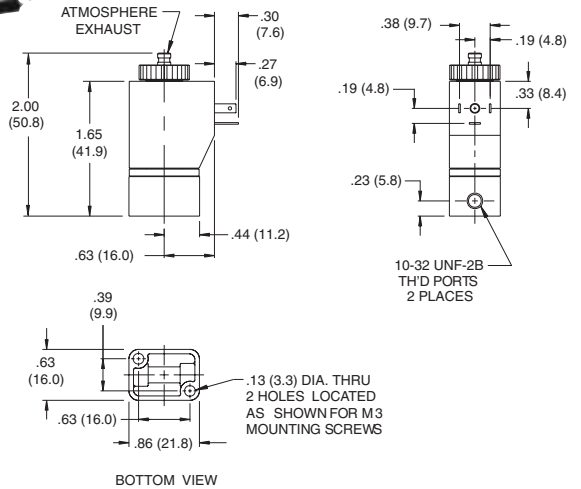

2-Way Normally Closed

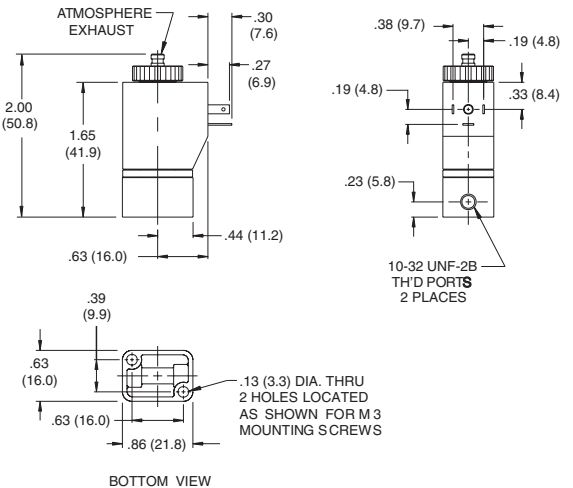

3-Way Normally Closed Exhaust to Atmosphere

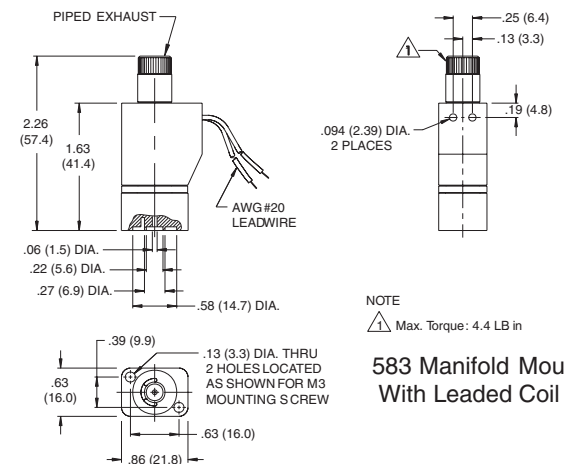

3-Way Normally Closed Piped Exhaust

583 Manifold Mount With Leaded Coil

SOLENOID VALVES . . .























Table A	FLOW CONFIGURATION	Valve No:	Max Operating Pressure Differential		3.5 Watts Orifice Size		CV Factor	
			AC	DC	Inlet	Exhaust	Inlet	Exhaust
Model 581 2 Way Normally Open	DE-ENERGIZED ENERGIZED 2 WNO   OUT (C) OUT (C) IN (B) IN (B)	581A15PE	300	300		.6MM		0.010
		581F15PE	275	275		.8MM		0.020
		581M15PE	230	230		1.0MM		0.030
		581W15PE	150	150		1.2MM		0.034
Model 582 2 Way Normally Closed	DE-ENERGIZED ENERGIZED 2 WNC   OUT OUT IN IN	582A15DE	300	300	.6MM		0.010	
		582F15DE	250	250	.8MM		0.020	
		582M15DE	150	150	1.0MM		0.030	
		582W15DE	135	135	1.2MM		0.034	
Model 583 3 Way Normally Closed Exhaust to Atmosphere	DE-ENERGIZED ENERGIZED 3 WNC   IN IN CYL CYL	583AA15DE	300	300	.6MM	.6MM	0.010	0.010
		583AF15DE	300	300	.6MM	.8MM	0.010	0.020
		583FF15DE	250	250	.8MM	.8MM	0.020	0.020
		583MM15DE	145	145	1.0MM	1.0MM	0.030	0.030
		583WW15DE	100	100	1.2MM	1.2MM	0.034	0.034
Model 583 3 Way Normally Closed Piped Exhaust	DE-ENERGIZED ENERGIZED 3 WNC   IN IN CYL CYL EXH EXH	583AA15PE	300	300	.6MM	.6MM	0.010	0.010
		583AF15PE	300	300	.6MM	.8MM	0.010	0.020
		583FF15PE	250	250	.8MM	.8MM	0.020	0.020
		583MM15PE	145	145	1.0MM	1.0MM	0.030	0.030
		583WW15PE	100	100	1.2MM	1.2MM	0.034	0.034
Model 584 3 Way Normally Open	DE-ENERGIZED ENERGIZED 3 WNO   IN (C) IN (C) (A) EXH (A) EXH CYL (B) CYL (B)	584AA15PE	145	145	.6MM	.6MM	0.010	0.010
		584FF15PE	100	100	.8MM	.8MM	0.020	0.020
		584MM15PE	50	50	1.0MM	1.0MM	0.030	0.030
		584WW15PE	40	40	1.2MM	1.2MM	0.034	0.034
Model 585 3 Way Directional Control	DE-ENERGIZED ENERGIZED 3 WDC   N.O. (C) N.O. (C) (A) N.C. (A) N.C. IN (B) IN (B)	585AA15PE	300	300	.6MM	.6MM	0.010	0.010
		585FF15PE	200	200	.8MM	.8MM	0.020	0.020
		585MM15PE	50	50	1.0MM	1.0MM	0.030	0.030
		585WW15PE	35	35	1.2MM	1.2MM	0.034	0.034
Model 586 3 Way Multi- Purpose	DE-ENERGIZED ENERGIZED 3 WMP   N.O. (C) N.O. (C) (A) N.C. (A) N.C. COM. (B) COM. (B)	586AA15PE	145	145	.6MM	.6MM	0.010	0.010
		586FF15PE	100	100	.8MM	.8MM	0.020	0.020
		586MM15PE	50	50	1.0MM	1.0MM	0.030	0.030
		586WW15PE	20	20	1.2MM	1.2MM	0.034	0.034

Table B	FLOW CONFIGURATION	Valve No:	Max Operating Pressure Differential		.9 Watts Orifice Size		CV Factor	
			AC	DC	Inlet	Exhaust	Inlet	Exhaust
Model L581 2 Way Normally Open	DE-ENERGIZED ENERGIZED 2 WNO   OUT (C) OUT (C) IN (B) IN (B)	L581A15PE	150	150		.6MM		0.010
		L581F15PE	130	130		.8MM		0.020
Model L582 2 Way Normally Closed	DE-ENERGIZED ENERGIZED 2 WNC   OUT OUT IN IN	L582A15DE	150	150	.6MM		0.010	
Model L583 3 Way Normally Closed Exhaust to Atmosphere	DE-ENERGIZED ENERGIZED 3 WNC   IN IN CYL CYL	L583AA15DE	145	145	.6MM	.6MM	0.010	0.010
		L583AF15DE	145	145	.6MM	.8MM	0.010	0.020
Model L583 3 Way Normally Closed Piped Exhaust	DE-ENERGIZED ENERGIZED 3 WNO   IN IN CYL CYL EXH EXH	L583AA15PE	145	145	.6MM	.6MM	0.010	0.010
		L583AF15PE	145	145	.6MM	.8MM	0.010	0.020



PETER PAUL

SERIES 40 PLASTIC VALVES (3.3 WATTS AC AND 5 WATTS DC)

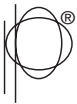
APPLICATION:

General purpose valves are engineered for competitive cost and reliable service in humidifiers, pneumatic actuation systems, beverage dispensers and other equipment.

SPECIFICATIONS—

OPERATING CONDITIONS

Media: The valves may be used with air, inert gas and liquid media.

Valve Temperature Range: Standard Valves - 0°F (-18°C) to 104°F (40°C) ambient; 0°F (-18°C) to 150°F (60°C) media. Optional Valves - can tolerate much higher or much lower ambient and media temperatures. Consult factory for specifications.

Maximum Operating Pressure Differentials: See catalog listings

Burst Pressure: 1000 PSI

Leakage: Bubble tight for standard valves

Vacuum: To 5 Microns - Consult factory

ELECTRICAL CHARACTERISTICS

Coil Voltage: 24 to 277 VAC 50-60 HZ.—6 to 120 VDC. All standard voltages (U.S. & Export) carried in stock. Special voltages readily produced on order.

Nominal Power:

<u>D.C. VALVES</u>	<u>A.C. VALVES</u>
5 Watts	3.3 watts

Coil Construction: Standard, Molded with 24" leads.

Typical Response Time on Air: 4-16 Milliseconds

Operating Speed: Up to 600 CPM

Duty Cycle: Continuous or Intermittent

MECHANICAL CHARACTERISTICS

Material: All interior parts are stainless steel and, acetal and PET.

Orifice Diameter: See catalog listings

Porting: 1/8 NPT

Life expectancy: Millions of cycles, depending on application, lubrication, etc.

Valve Weight: Only .27 (14 1/2 oz.) lbs average

Repair Packs: Consult Factory

FOR FLOW CHARTS SEE PAGES 95-97

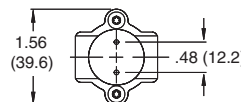
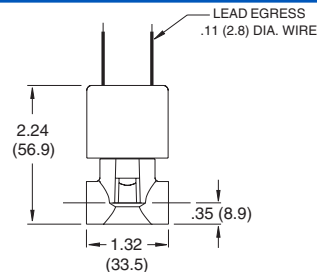
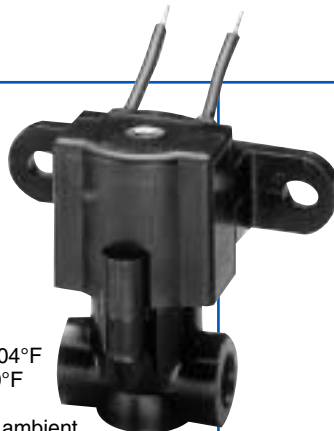

BOTTOM MOUNTING HOLES
.072 (1.83) DIA. X .19 (4.8) DEEP
(#2 PLASTITE SCREWS)

2-Way and 3-Way Normally Closed Exhaust to Atmosphere

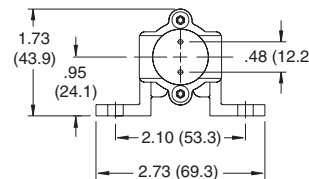
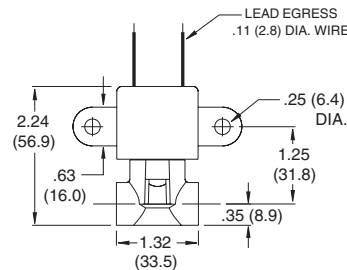

BOTTOM MOUNTING HOLES
.072 (1.83) DIA. X .19 (4.8) DEEP
(#2 PLASTITE SCREWS)

With Bracket

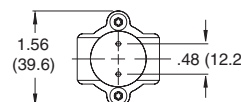
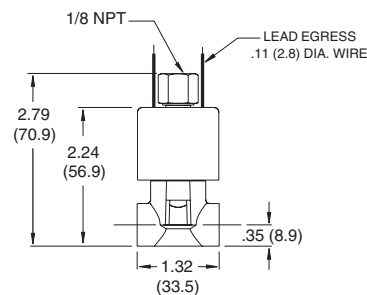

BOTTOM MOUNTING HOLES
.072 (1.83) DIA. X .19 (4.8) DEEP
(#2 PLASTITE SCREWS)

3-Way Normally Closed Piped Exhaust

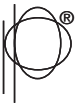

SOLENOID VALVES . . .

MODEL TYPE	FLOW CONFIGURATION	Valve No: Without Bracket	Valve No: With Bracket	Max Operating Pressure Differential		Orifice Size		CV Factor	
				AC	DC	Inlet	Exhaust	Inlet	Exhaust
Model 42 2 Way Normally Closed		42G5DGM** 42H5DGM** 42J15DGM 42K15DGM 42N15DGM	42G5DBM** 42H5DBM** 42J15DBM 42K15DBM 42N15DBM	300	300	1/32		0.022	
				300	150	3/64		0.055	
				300	100	1/16		0.090	
				250	60	3/32		0.145	
				125	30	1/8		0.200	
Model 43 Exhaust To Atmosphere		43JJ15DGM 43KK15DGM 43NK15DGM	43JJ15DBM 43KK15DBM 43NK15DBM	150	150	1/16	1/16	0.090	0.075
				60	60	3/32	3/32	0.145	0.145
				30	30	1/8	3/32	0.200	0.145
Model 43 Piped Exhaust		43JJ15XGM 43KK15XGM 43NK15XGM	43JJ15XBM 43KK15XBM 43NK15XBM	150	150	1/16	1/16	0.090	0.075
				60	60	3/32	3/32	0.145	0.145
				30	30	1/8	3/32	0.200	0.145

SERIES 40 SOLENOID VALVES OPTIONAL BRASS BODIES*



S-40 Forged Brass Body,
1/4 Compression fittings, with Filter
Available with or without bracket.

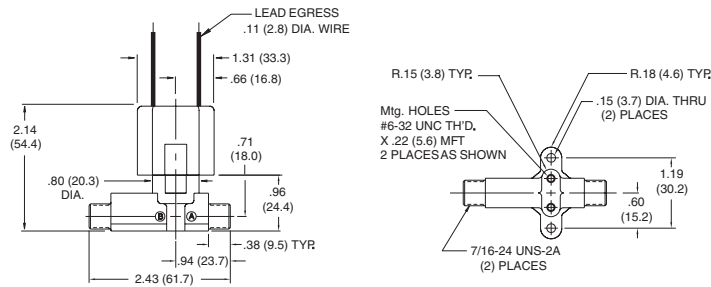

S-40 Forged Brass Body, 1/8 NPT Male Fittings
Plastic Overmold
Available with or without bracket.

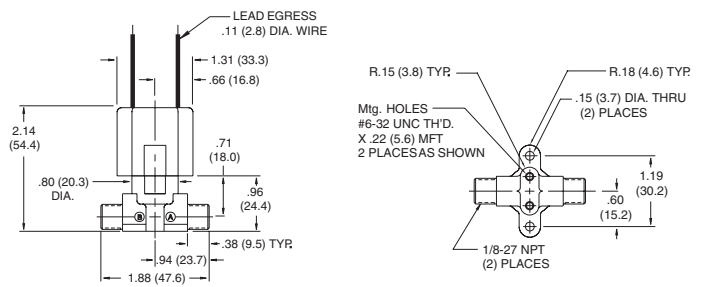

S-40 Forged Brass Body, 1/4 Compression fittings,
Plastic Overmold
Available with or without bracket.

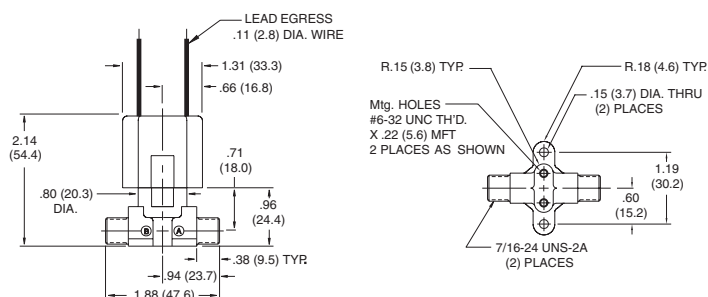

S-40 Forged Brass Body, 1/8 NPT Female fittings,
Plastic Overmold
Available with or without bracket.

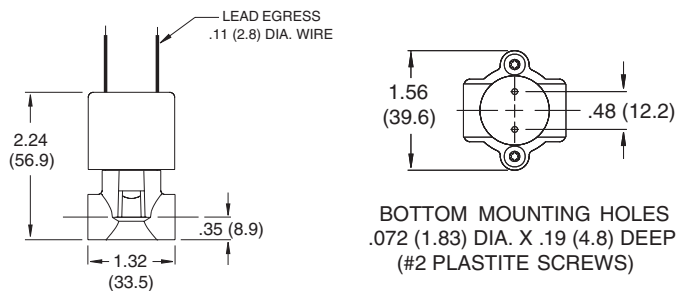

** These orifice sizes available only with Brass Bodies
* Brass Bodies have a 3/32 Maximum Orifice Size.

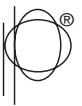

PETER PAUL

SERIES 20 High Flow Low Pressure Model 22T

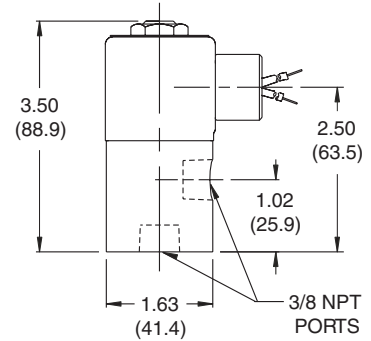
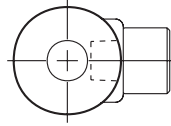
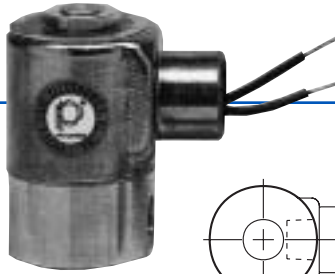

SPECIFICATIONS - OPERATING CONDITIONS

Media: Air and other fluids, compatible with standard Buna seals. Hot water, steam, gasoline, and many oils require special seal materials - Consult factory.

Valve Temperature Range: STANDARD VALVES – 0°F (-18°C) to 104°F (40°C) ambient; 0°F (-18°C) to 150°F (65°C) media. OPTIONAL VALVES – can tolerate much higher or much lower ambient and media temperatures. Consult factory for specifics.

Burst Pressure: Series 20 - 5000 PSI

Leakage: Bubble tight for standard valves

Vacuum: To 15° Mercury

ELECTRICAL CHARACTERISTICS

Coil Voltage: 5 to 825 VAC 50-60 HZ.

Nominal Power: 7.7 Watts AC

Coil Construction: Molded and Non-Molded.

Typical Response Time on Air: 4-16 Milliseconds

MECHANICAL CHARACTERISTICS

Body: Stainless steel

Porting: 3/8" NPT

Housing: Grommet & 1/2 NPT conduit - many options available

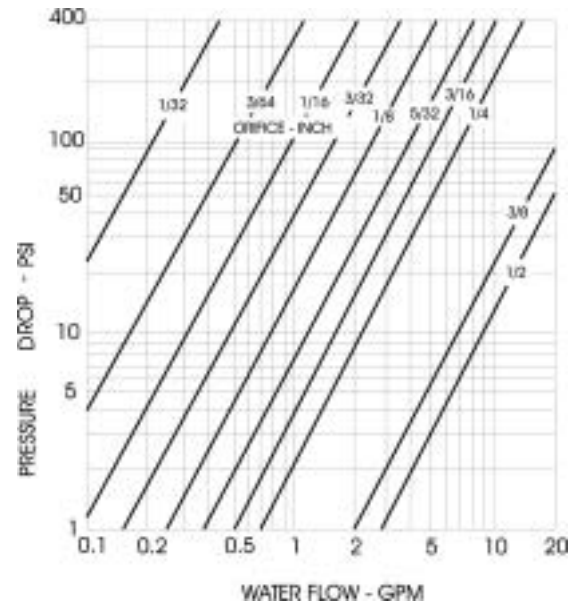

MAX. PRESS DROP P.S.I.	ORIFICE SIZE	CV FACTOR	VALVE NUMBER
AC			GROMMET HOUSING 3/8 NPT PIPE PORTS
0 - 10	3/8	2.0	22T1DGV _____
or up to 15° vacuum			CONDUIT HOUSING 3/8 NPT PIPE PORTS
			22T1DCV _____

WHEN ORDERING ADD VOLTAGE AND FREQUENCY TO COMPLETE VALVE NUMBER.

EXAMPLE: (22TDGV-120/60)

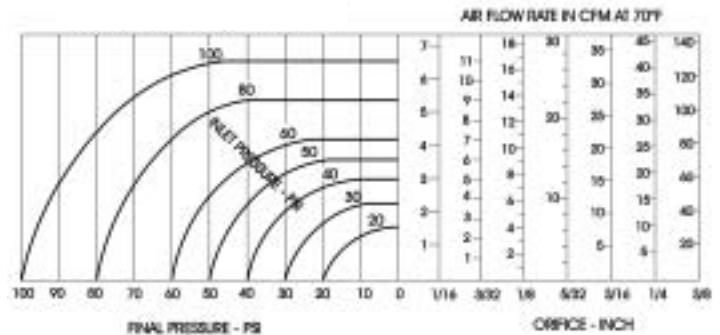

OPTIONS AVAILABLE:

HOUSING OPTIONS *see page 78
STRAIN RELIEF CONNECTOR

SINGLE AUTOMOTIVE

DOUBLE AUTOMOTIVE

“AN” CONNECTOR

MOUNTING BRACKET

COIL OPTIONS *see page 79

MOLDED COIL

POTTED COIL & HOUSING

HIGH TEMPERATURE MOLDED COIL

MISCELLANEOUS OPTIONS see page 76

SILVER SHADING RING

ALUMINUM SHADING RING

Note: Availability of certain options or combination of options may vary with quantity of units ordered - Consult representative or factory



PETER PAUL

SERIES 70 HIGH FLOW MODEL 72



TWO-WAY NORMALLY CLOSED VALVES
LOW PRESSURE & VACUUM APPLICATIONS

NOW! MORE CAPABILITIES AND CAPACITIES FROM THE 70 SUPER VALVE SERIES.

THIS "72" PROVIDES **HIGH FLOW** at low pressures

- Vacuum lines • Low pressure gas and low pressure liquids
- Gravity feed lubrication • Quick media fill or dump

SPECIFICATIONS

Catalog Number	72T10DCM	72B11DCM
Valve Type	2WNC	2WNC
Orifice Diameter	3/8"	1/2"
Flow Rate	see curves	see curves
CV Factor	1.92	2.92
Pipe Size	3/8 NPT	1/2 NPT
Internal Leakage	bubble tight	bubble tight
External Leakage	bubble tight	bubble tight
Maximum Operating Pressure Differential	25 PSI	15 PSI
Vacuum	down to 5 microns	down to 5 microns
Repair Packs	K72TDD (A.C. or D.C.)	K72BDD (A.C. or D.C.)

72T10DCM & 72B11DCM

- Voltage** most A.C. & D.C. voltages
- Wattage** 18 watts A.C., 16 watts D.C.
- Response Time**
 - (On Air) 6 to 12 milliseconds to open; 12 to 28 milliseconds to close
- Operating Speed** up to 350 cycles per minute
- Heat Rise** 80°C (176°F) max. in 25°C ambient for continuous duty
- Valve Temperature Range:** STANDARD VALVES – 0°F (-18°C) to 104°F (40°C) ambient; 0°F (-18°C) to 150°F (65°C) media. OPTIONAL VALVES – can tolerate much higher or much lower ambient and media temperatures. Consult factory for specifics.
- Proof Pressure** 5 times maximum operating pressure differential
- Burst Pressure** 500 psi
- Media** air, inert gases and oil
- Filtration** helpful but not required
- Lubrications** helpful but not required
- Ambient Temperature**
 - Range 18°C (0°F) to 40°C (104°F)
- Life Expectancy** millions of cycles on most applications
- Vibrations & Shock** 3 G's and above
- Elastomers** FKM (standard)
- *Body** Aluminum anodized, corrosion resistant (All other parts stainless steel)

*Different materials for special applications can be made available.
i.e. STAINLESS STEEL body for hostile conditions. Consult factory.

AIR FLOW CURVES

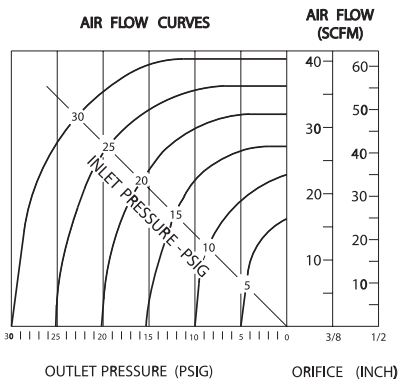

WATER FLOW CURVES

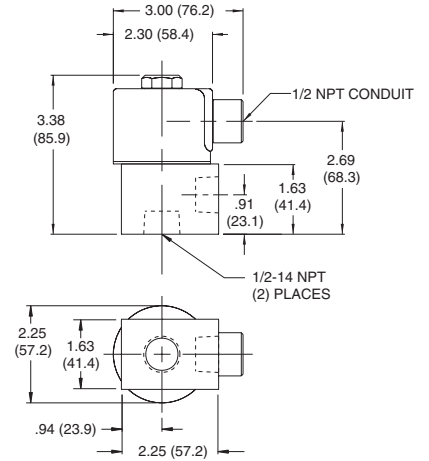
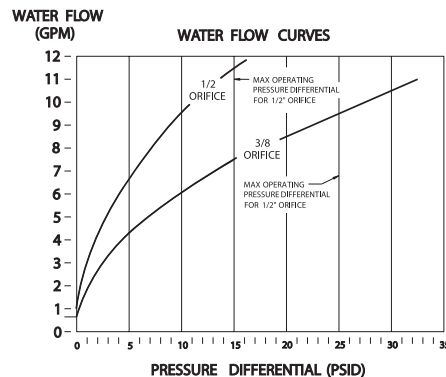

SERIES 70 1/2" ORIFICE 2-WAY N.C. VALVE

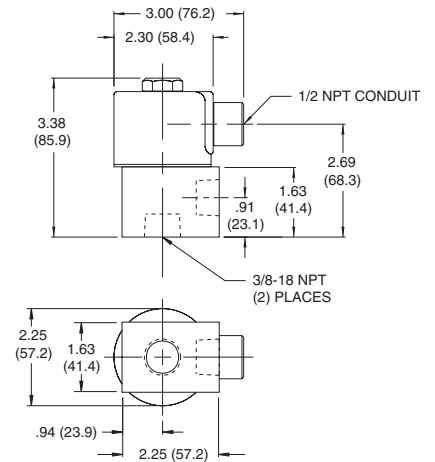

SERIES 70 3/8" ORIFICE 2-WAY N.C. VALVE



PETER PAUL

SERIES 80 LARGE ORIFICE TWO WAY DIAPHRAGM VALVES

NEW! Up to 3" NPT and stainless steel bodies available. Consult factory.

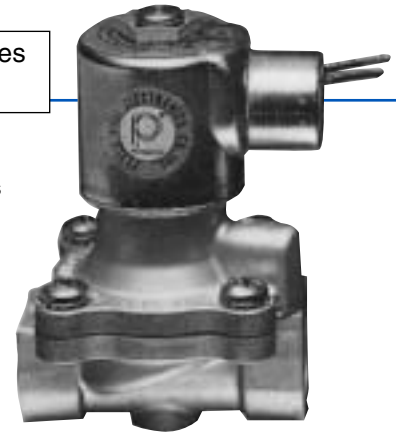

SERIES 80 Valves for general applications are available **normally closed** or **normally open**.

Models 818 and 828 are solenoid operated diaphragm valves that use a differential pressure principal. (Internal Pilot).

Model 827 is a solenoid operated diaphragm valve that can operate at low pressures without any differential pressure across the diaphragm (Direct Lift).

The 80 Series has been designed for high flow applications—large ½ diameter orifice.

80 Series valves are constructed with the same quality materials and workmanship as the smaller Peter Paul Valves. Bodies are made of strong brass forgings.

Internal metal parts are stainless steel. Seals are made from Nitrile Rubber (Buna N). Other materials can be provided for special applications.

80 Series valves can be used with most common media—water—air—oil—etc.

80 Series valves use the same coils and housings as Peter Paul's popular 20 Series valves, therefore, the same wide range of voltages and variations in coil construction and housing configurations are available.

Nominal Power Consumption

D.C.—9.5 Watts A.C.—7.7 Watts (Typical)

Valve Temperature Range: STANDARD VALVES – 0°F (-18°C) to 104°F (40°C) ambient; 0°F (-18°C) to 150°F (65°C) media.

OPTIONAL VALVES – can tolerate much higher or much lower ambient and media temperatures. Consult factory for specifics.

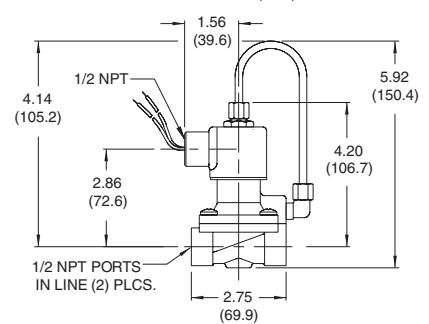
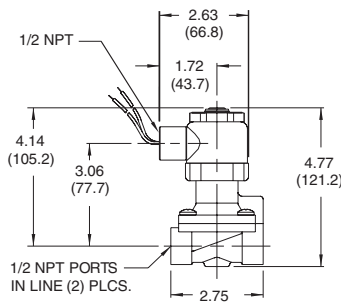
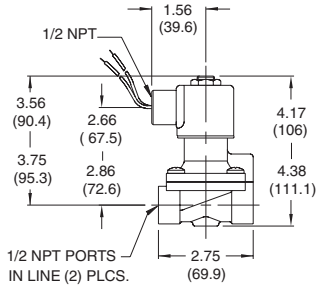
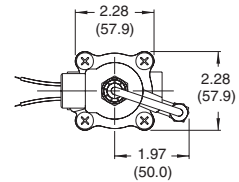
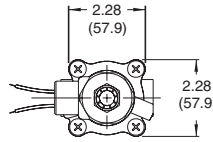
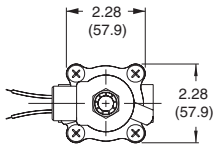

827

E828

818

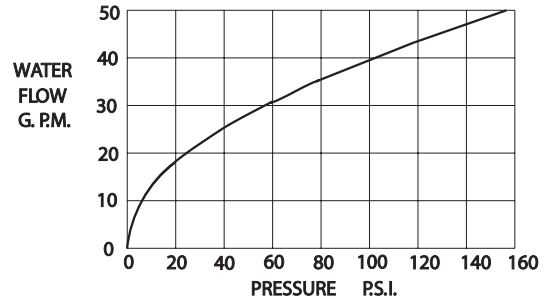
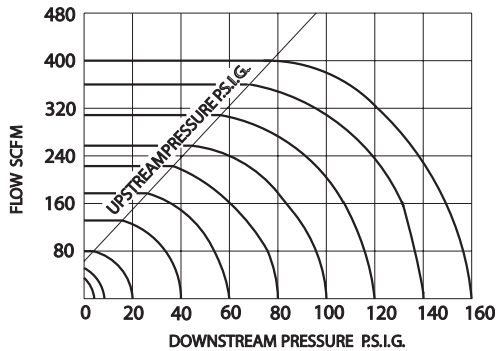

VALVE TYPE	VALVE NUMBER (CONDUIT HOUSING)	ORIFICE SIZE	PIPE SIZE	MAXIMUM OPERATING PRESSURE AC	MAXIMUM OPERATING PRESSURE DC	MINIMUM OPERATING PRESSURE	CV FACTOR
Normally Closed - Direct Lift	827C12DCV	5/8	1/2 NPT	100 PSI	40 PSI	0	4.0
Normally Closed - Internal Pilot	828C12DCV	5/8	1/2 NPT	150 PSI	150 PSI	5 PSI	4.0
Normally Open - Internal Pilot	818C12DCV	5/8	1/2 NPT	150 PSI	150 PSI	5 PSI	4.0
Normally Closed - Internal Pilot - Explosion Proof	E828C12DCCM	5/8	1/2 NPT	150 PSI	150 PSI	5 PSI	4.0
Normally Closed - Internal Pilot - Explosion Proof	E818C12DCCM	5/8	1/2 NPT	150 PSI	150 PSI	5 PSI	4.0

828 LARGE ORIFICE VALVE WITH SOLID STATE TIMER

In many applications timing is everything

The 828 2 way normally closed valve is particularly suited to applications like draining condensation in compressed air systems. The timer provides the versatility needed for this function. The 828 integrated timer/valve creates opportunities for hundreds of applications.

80 Series valves are constructed with the same quality materials and workmanship as the smaller Peter Paul Valves. Bodies are made of strong brass forgings. Internal metal parts are stainless steel. Seals are made from Nitrile Rubber (Buna N). Other materials can be provided for special applications. 80 Series valves can be used with most common media—water—air—oil—etc.

80 Series valves use the same coils and housings as Peter Paul's popular 20 Series valves, therefore, the same wide range of voltages, variations in coil construction and housing configurations are available.

For OTHER VALVES and VALVE CONFIGURATIONS WITH TIMERS – consult PETER PAUL.
(This timer can be used with series "20" and "30" valves.)



SPECIFICATIONS

PRESSURE 5-150 PSI **VOLTAGE** 120/60 110/50 240 A.C.

PIPE SIZE 1/2 NPT (in line) – **ORIFICE** 5/8"

NOMINAL POWER CONSUMPTION 9.5 Watts

LINE CORD 6 Ft. w/ Standard Three Prong Plug

TIMER ADJUSTMENT:

Off Time 1 to 45 min. **On Time** .25 sec. to 25 sec.

PUSH BUTTON MANUAL OVERRIDE

STATUS LIGHTS to show power and operation.

Timer and coil may be rotated 360°

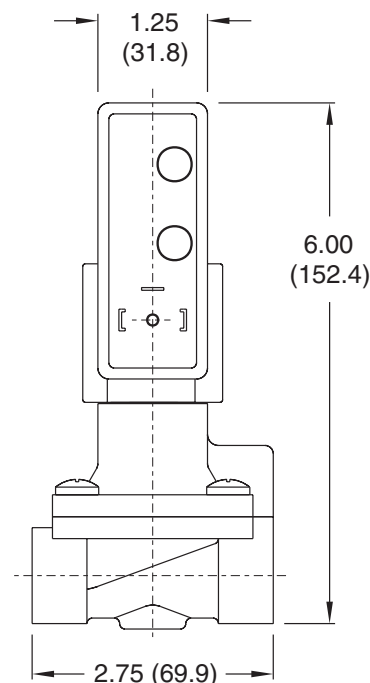
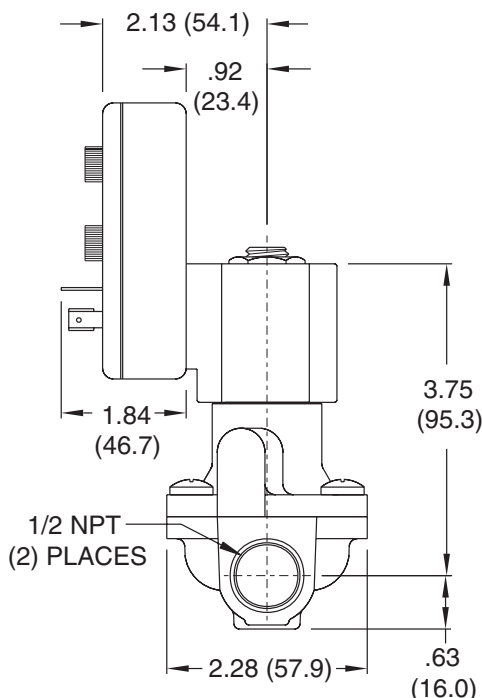

TIMER FUNCTION

Upon application of power to the input terminals, the off cycle is initiated. At the end of the pre-set off time, the solenoid is energized and the on cycle begins. At the end of the preset on time, power is removed from the solenoid and a new cycle begins. Cycling continues until power is removed from the input terminals.

SPECIAL APPLICATIONS

Series 30 - Model F32 - Filter Valve

SPECIFICATIONS - OPERATING CONDITIONS

Media: Air, water.

Valve Temperature Range: STANDARD VALVES – 0°F (-18°C) to 104°F (40°C) ambient; 0°F (-18°C) to 150°F (65°C) media. OPTIONAL VALVES – can tolerate much higher or much lower ambient and media temperatures. Consult factory for specifics.

Burst Pressure: Series 30 - 4000 PSI

Leakage: Bubble tight

ELECTRICAL CHARACTERISTICS

Coil Voltage: 5 to 650 VAC 50-60 HZ – 2 to 240 V DC

Nominal Power: 9 Watts AC & DC

Coil Construction: Molded and Non-Molded.

Typical Response Time on Air: 4-16 Milliseconds

MECHANICAL CHARACTERISTICS

Body: Brass (Standard)
Stainless Steel (Optional)

Porting: 1/8" NPT

Housing: Grommet & 1/2 NPT conduit - many options available

Filtration: 140 MICRON

NOTE: OTHER MICRON FILTRATION IS AVAILABLE—CONSULT FACTORY

MAX. PRESS		ORIFICE		CV FACTOR	VALVE NUMBER	
DROP P.S.I.	ORIFICE SIZE	GROMMET HOUSING 1/8 NPTF PIPE PORTS	CONDUIT HOUSING 1/8 NPTF PIPE PORTS			
280	280	3/64	.055	F32H5DBGV	F32H5DBCV	
280	250	1/16	.105	F32J5DBGV	F32J5DBCV	
180	100	3/32	.195	F32K5DBGV	F32K5DBCV	
130	80	7/64	.220	F32L5DBGV	F32L5DBCV	
90	50	1/8	.275	F32N5DBGV	F32N5DBCV	

WHEN ORDERING ADD VOLTAGE AND FREQUENCY TO COMPLETE VALVE NUMBER. EXAMPLE: (F32H5DBGV-120/60)

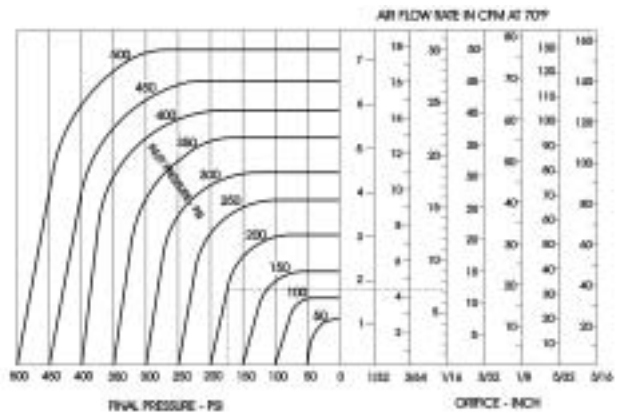
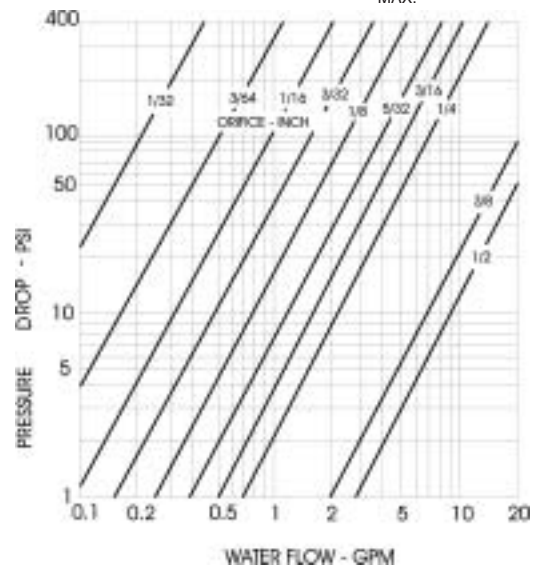
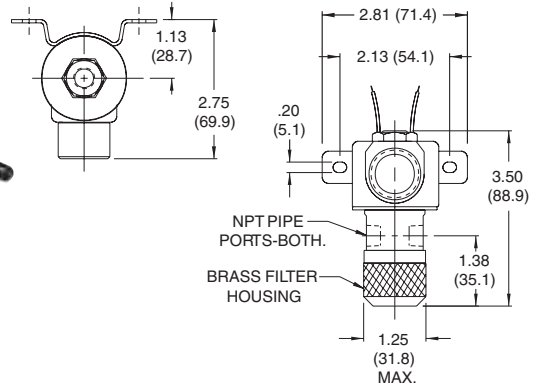
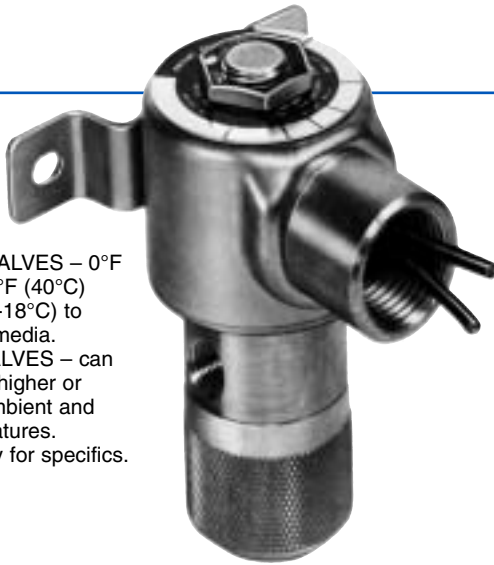

OPTIONS AVAILABLE: -SPECIAL APPLICATION VALVES

HOUSING OPTIONS *see page 78
STRAIN RELIEF CONNECTOR

SINGLE AUTOMOTIVE

DOUBLE AUTOMOTIVE

"AN" CONNECTOR

MOUNTING BRACKET

COIL OPTIONS *see page 79

MOLDED COIL

POTTED COIL & HOUSING

HIGH TEMPERATURE MOLDED COIL

MISCELLANEOUS OPTIONS see page 76

SILVER SHADING RING

ALUMINUM SHADING RING

Note: Availability of certain options or combination of options may vary with quantity of units ordered - Consult representative or factory

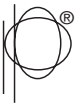

PETER PAUL

Series 50 - Media Isolation Valve

Meet today's demands for economy of space and energy consumption.

APPLICATION:

Compact, Series 50 solenoid valves are now configured with molded nylon valve bodies and custom porting which isolate potentially corrosive media from the valve operator for applications in the medical, instrumentation, chemical, and food processing industries. These 2-way normally closed valves, are available for both continuous and intermittent duty, based on the back pressure encountered in operation.

SPECIFICATIONS - OPERATING CONDITIONS

Type: 2-Way Normally Closed

Media: Liquids compatible with Nylon and Nitrile (Gas, possible)

Maximum Inlet Pressure: 50 PSI

Power: 4.25 Watts AC, 7.25 Watts DC

Electrical Connections: 1/4" Spade Terminals

Back Pressure: 5 PSI Maximum

Fluid Connections: Inlet – 1/8 NPT Female Port (Side)
Outlet – 1/8 NPT Male Port (Bottom)

Orifice: 3/64"

Flow: Cv = 0.037

Mounting Position: Vertical Recommended

Coil: Molded – Class A (can be rotated 360°)

Voltages: All common AC and DC Voltages

Options: Silicone or EPDM Diaphragms Available

INTERMITTENT DUTY

Maximum Inlet Pressure: 35 PSI

Voltage: All common DC Voltages

Power: 17 Watts DC

Duty Cycle: 0.167 Minutes ON Max.
0.833 Minutes OFF Min.

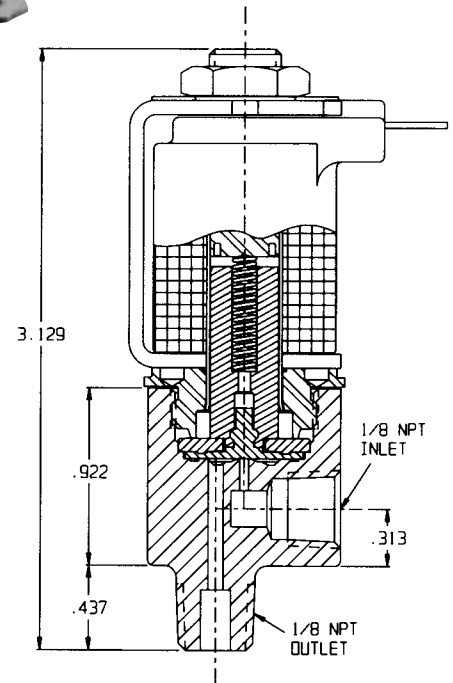

WATER FLOW

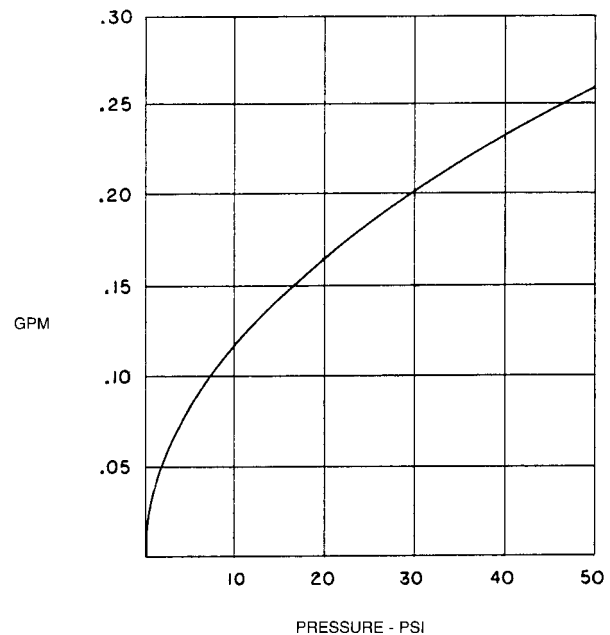

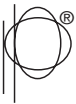

PETER PAUL

SERIES 20 Magnetic Latching Valve

Meet today's demands for economy of space and energy consumption.

APPLICATION:

This type of valve is often used in remote areas where continuous power may not be available or with battery-powered portable equipment where power capacity is limited. It is also valuable in equipment where coil heating, due to continuous applications of power, is undesirable such as in medical and chemical analyzers, etc.

SPECIFICATIONS—

OPERATING CONDITIONS

Media: Air and other fluids, compatible with standard Buna seals. Hot water, steam, gasoline, oils, some hydraulic fluids, and many other media require special seal materials - Consult representative of factory.

Valve Temperature Range: Standard Valves - 0°F (-18°C) to 104°F (40°C) ambient; 0°F (-18°C) to 150°F (65°C) media. Optional Valves - can tolerate much higher or much lower ambient and media temperatures. Consult factory for specifications.

Maximum Operating Pressure Differentials: See catalog listings

Burst Pressure: 5000 PSI

Leakage: Bubble tight for standard valves

Vacuum: To 5 Microns - Consult factory

ELECTRICAL CHARACTERISTICS

Coil Voltage: 6 to 60 VDC. All standard voltages (U.S. & Export) carried in stock. Special voltages readily produced on order.

Nominal Power: 10 watts

Typical Response Time on Air: Approximate 30 millisecond pulse to energize
Approximate 30 millisecond pulse to de-energize

Operating Speed: Up to 60 CPM

Duty Cycle: Continuous

MECHANICAL CHARACTERISTICS

Material: All interior parts are stainless steel

Orifice Diameter: See catalog listings

Porting: See catalog listings

Housing: European style DIN COIL for your convenience we have the female DIN style mating connector No. 20-198** available for an additional fee.

Life expectancy: Millions of cycles, depending on application, lubrication, etc.

Valve Weight: 1.2 lbs lbs average

Repair Packs: Consult Factory

Metering, bottom orifice or cavity porting, manifold mount, built in muffler, universal mounting bracker, brass body.

FOR FLOW CHARTS SEE PAGES 95-97

SOLENOID VALVE OPERATORS

A complete line of valve operators for O.E.M. applications are offered for those who wish to incorporate them in their own product line. Full technical information and details are available from Peter Paul.

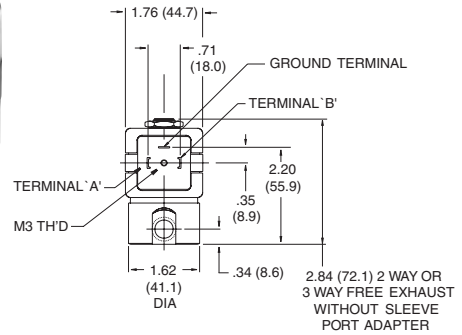

2-Way Normally Closed

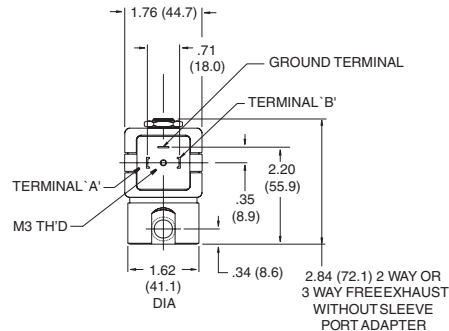
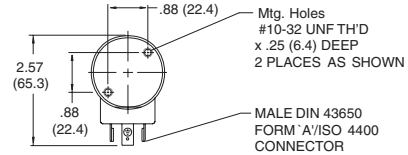

3-Way Normally Closed Exhaust to Atmosphere

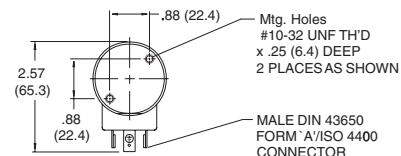
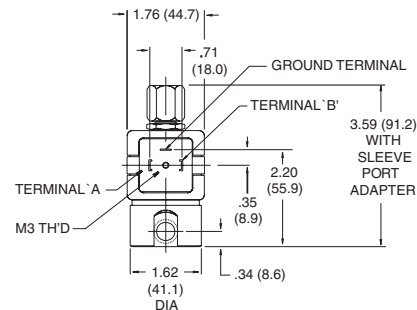
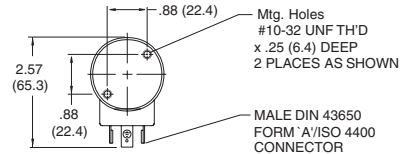

3-Way Normally Closed Piped Exhaust

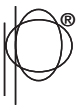

SOLENOID VALVES . . .

MODEL TYPE	FLOW CONFIGURATION	Valve No: 1/8 NPT	Valve No: 1/4 NPT	Max Operating Pressure Differential	Orifice Size		CV Factor			
				DC	Inlet	Exhaust	Inlet	Exhaust		
Model 21 2 Way Normally Open	DE-ENERGIZED ENERGIZED 	21G7XELM	21G9ZELM	400		1/32		.024		
		21H7XELM	21H9ZELM	235		3/64		.053		
		21J7XELM	21J9ZELM	150		1/16		.095		
		21K7XELM	21K9ZELM	100		3/32		.156		
Model 22 2 Way Normally Closed	DE-ENERGIZED ENERGIZED 	22G7DELM	22G9DELM	500	1/32		.024			
		22H7DELM	22H9DELM	250	3/64		.052			
		22J7DELM	22J9DELM	200	1/16		.095			
		22K7DELM	22K9DELM	125	3/32		.156			
		22N7DELM	22N9DELM	100	1/8		.214			
		22O7DELM	22O9DELM	50	5/32		.404			
		22P7DELM	22P9DELM	25	3/16		.500			
		22R7DELM	22R9DELM	5	1/4		.700			
		22S9DELM	22S9DELM		5/16		1.000			
		Model 23 3 Way Normally Closed Exhaust to Atmosphere	DE-ENERGIZED ENERGIZED 	23GG7DELM	23GG9DELM	400	1/32	1/32	.024	.024
23HJ7DELM	23HJ9DELM			150	3/64	1/16	.052	.095		
23JJ7DELM	23JJ9DELM			100	1/16	1/16	.095	.095		
23JK7DELM	23JK9DELM			100	1/16	3/32	.095	.156		
23KK7DELM	23KK9DELM			75	3/32	3/32	.156	.156		
23NK7DELM	23NK9DELM			50	1/8	3/32	.214	.156		
23PK7DELM	23PK9DELM			20	3/16	3/32	.500	.156		
23RK7DELM	23RK9DELM				1/4	3/32	.700	.156		
Model 23 3 Way Normally Closed Piped Exhaust	DE-ENERGIZED ENERGIZED 			23GG7XELM	23GG9ZELM	400	1/32	1/32	.024	.024
				23HJ7XELM	23HJ9ZELM	150	3/64	1/16	.052	.095
		23JJ7XELM	23JJ9ZELM	100	1/16	1/16	.095	.095		
		23JK7XELM	23JK9ZELM	100	1/16	3/32	.095	.156		
		23KK7XELM	23KK9ZELM	75	3/32	3/32	.156	.156		
		23NK7XELM	23NK9ZELM	50	1/8	3/32	.214	.156		
		23PK7XELM	23PK9ZELM	20	3/16	3/32	.500	.156		
		23RK7XELM	23RK9ZELM		1/4	3/32	.700	.156		
		Model 24 3 Way Normally Open	DE-ENERGIZED ENERGIZED 	24GG7XELM	24GG9ZELM	400	1/32	1/32	.024	.024
				24HJ7XELM	24HJ9ZELM	150	3/64	1/16	.052	.095
24JJ7XELM	24JJ9ZELM			100	1/16	1/16	.095	.095		
24JK7XELM	24JK9ZELM			100	1/16	3/32	.095	.156		
24JN7XELM	24JN9ZELM			100	1/16	1/8	.095	.214		
24KN7XELM	24KN9ZELM			75	3/32	1/8	.156	.214		
Model 25 3 Way Directional Control	DE-ENERGIZED ENERGIZED 			25GG7XELM	25GG9ZELM	500	1/32*	1/32	.024*	.024
		25HH7XELM	25HH9ZELM	235	3/64*	3/64	.052*	.052		
		25JH7XELM	25JH9ZELM	200	1/16*	3/64	.095*	.052		
		25JJ7XELM	25JJ9ZELM	150	1/16*	1/16	.095*	.095		
		25KK7XELM	25KK9ZELM	100	3/32*	3/32	.156*	.156		
		25NK7XELM	25NK9ZELM	100	1/8*	3/32	.214*	.156		
		Model 26 3 Way Multi- Purpose	DE-ENERGIZED ENERGIZED 	26GG7XELM	26GG9ZELM	400	1/32*	1/32	.024*	.024
26HH7XELM	26HH9ZELM			150	3/64*	3/64	.052*	.052		
26JJ7XELM	26JJ9ZELM			100	1/16*	1/16	.095*	.095		
26KK7XELM	26KK9ZELM			75	3/32*	3/32	.156*	.156		

Extended pressure rating available. Consult factory.

SERIES O20

For two and three-way OEM applications. Peter Paul offers a complete line of operators to control most media. Available up to 1/4" orifice. Consult factory for technical data and detail prints.

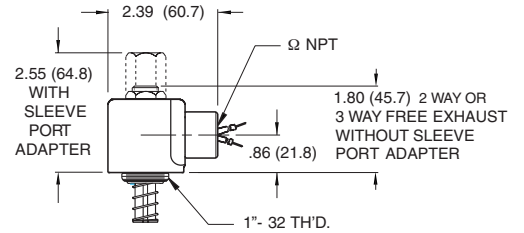

SERIES OE20 EXPLOSION PROOF SOLENOID OPERATORS

For two and three-way OEM application Peter Paul's unique, unitized design offers the advantages of simplicity of installation (unit is assembled and tested requiring no disassembly) for common voltages and frequencies and carries the U.L. and C.S.A. label. Approved for hazardous locations, Class I — Groups C and D (where atmosphere contains certain specific explosive gases). Class II — Group E (where atmosphere contains metallic dust). F (where atmosphere contains non-metallic combustible dust). And Group G (where atmosphere contains grain dust).

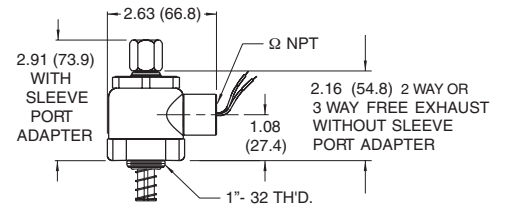

SERIES OH20

For 2WNC applications where high pressures are used—or where inert seals are required with bubble-tight sealing. Operator and precision press-in seat must be installed to factory specs. Consult factory for technical data and detail prints.

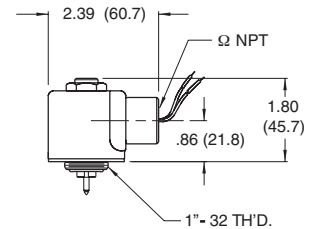

SERIES OEH20

For 2WNC applications where explosion-proof operators are required with high pressure ratings or inert seal requirement with bubble-tight sealing. Operator and precision press-in seat must be installed to factory specs. Consult factory for technical data and detail prints.

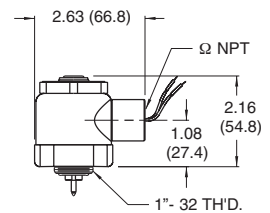

SERIES O30

For two-way and three-way OEM applications. Peter Paul offers a complete line of operators to control most media. Available up to 3/16" orifice. Consult factory for technical data and detail prints.

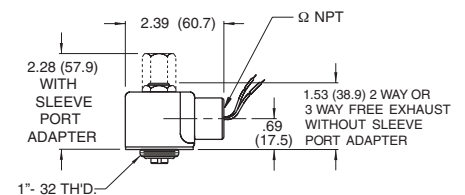

SERIES O50

For two-way and three-way OEM applications. Peter Paul offers a complete line of miniature operators to control most media. Available up to 1/8" orifice. Consult factory for technical data and detail prints.

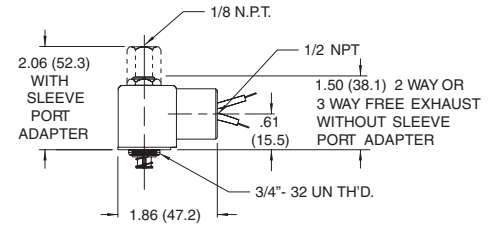

SERIES OE50

For two and three-way OEM application Peter Paul's unique, unitized design offers the advantages of simplicity of installation (unit is assembled and tested requiring no disassembly) for common voltages and frequencies and carries the U.L. and C.S.A. label. Approved for hazardous locations, Class I — Groups C and D (where atmosphere contains certain specific explosive gases). Class II — Group E (where atmosphere contains metallic dust). F (where atmosphere contains non-metallic combustible dust). And Group G (where atmosphere contains grain dust).

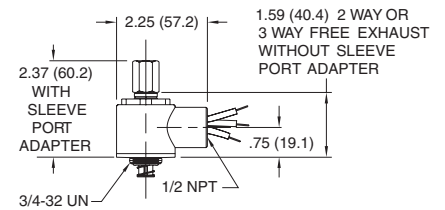

SERIES O70

For two-way and three-way OEM applications. Peter Paul offers a complete line of large capacity operators to control most media. Available up to 1/4" orifice. Consult factory for technical data and detail prints.

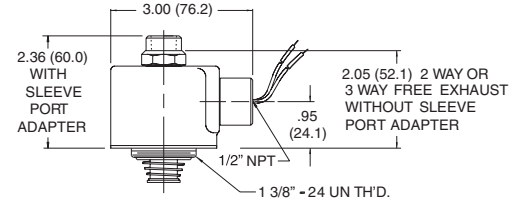

SERIES O15

For two-way and three-way OEM applications. Peter Paul offers a complete line of miniature operators to control most media. Available up to 3/32" orifices. This line's unique design incorporates the coil and magnetic structure encapsulated completely in molded epoxy. Consult factory for technical data and detail drawing of cavity machining dimensions.

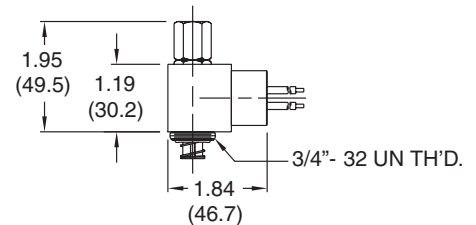

SERIES OELW

For two-way and three-way OEM applications. Peter Paul offers a complete line of miniature operators to control most media. Available up to 1/8" orifice. Consult factory for technical data and detail prints.

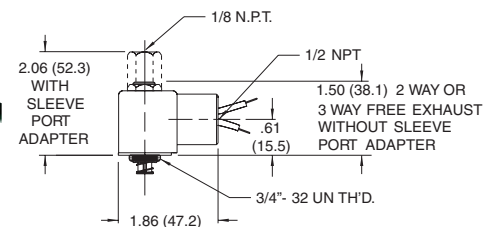



PETER PAUL VALVE TYPES — 2-WAY NORMALLY OPEN • 2-WAY NORMALLY CLOSED • 3-WAY NORMALLY OPEN • 3-WAY NORMALLY CLOSED EXHAUST TO ATMOSPHERE • 3-WAY NORMALLY CLOSED PIPE EXHAUST • 3-WAY DIRECTIONAL CONTROL • 3-WAY MULTI PURPOSE



SPECIALTY VALVES — A few of the many valve variations for custom or special purpose. We are prepared to make unusual valves available easily at any time.

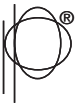

Broad Range of Solenoid Valve Manifolds



Typical of the standard and custom brass, aluminum, and stainless steel manifolds and stacking bodies we produce are (clockwise from 6) anodized aluminum modular stacking bodies with a variety of valve housings and common tie rod; anodized aluminum 2-station manifold with Series 50 conduit valves; 4-station manifold with Series 50 grommet valves; stainless steel 8-station directional control valve with Series 30 conduit valves; special 2-station aluminum block with Series 20 spade terminal coils; brass 3-station manifold with Series 15 DIN style connectors; brass manifold with 2-way NC Series 30 grommet valves; and 6-station anodized aluminum manifold with Series 50 yoke/spade terminal coils.

Standard, conventional, one-piece machined stainless steel, aluminum, or optional brass solenoid valve manifolds allow the economical, low profile grouping of valves in compact arrays. Like any other purpose-designed, machined component, these manifolds are perfect for fixed, continuous operations such as beverage dispensing. They are configurationally inflexible.

In an effort to solve these problems while retaining the simplicity and convenience of standard solenoid valve manifolds, we developed a line of modular, stainless steel and anodized aluminum stacking valve bodies linked together with common tie rods. For horizontal or vertical mounting, these stacking bodies simplify in-the-field solenoid valve addition or replacement and accommodate models from Peter Paul standard Series 50 and 15 valve series. These manifold building blocks simplify both OEM and user inventories; custom manifolds can be constructed using a variety of solenoid valve types in linear arrays. Each modular valve body is precision machined, drilled, and tapped just as complete manifolds are: The basic difference is that they are linked together by common threaded tie rods, with modules sealed from each other with O-rings, and sandwiched, as a group, together with precision machined end caps. The result is a unique and proprietary method for creating and altering groupings of solenoid valves while maintaining the significantly reduced potential for leakage and thread damage for which one-piece manifolds were originally designed.

Easily Mounted Screw-In Solenoid Valve Bodies Now Offered

We now produce new, brass, screw-in solenoid valve bodies offering simplified assembly, disassembly, and field replacement.

Our new screw-in valve bodies speed and simplify valve-to-manifold attachments. To help eliminate leakage and provide the required high burst pressure ratings, brass valve bodies are offered with 1/8" NPT and 1/4" NPT male ports, currently in our Series 50 valves. The standard ports also make the manifolds easier to produce, with one center drill connecting all the valves.

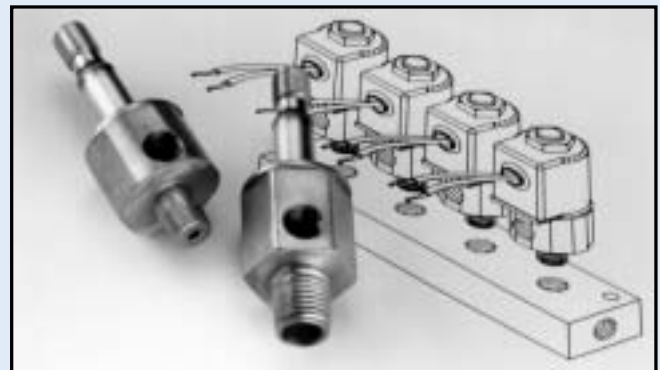

Our new brass, screw-in solenoid valve bodies with 1/8" NPT or 1/4" NPT male ports simplify valve-to-manifold attachment and manifold production. Shown here is a diagram of a four-station manifold, to which brass bodies with 1/8" NPT ports have been manually attached. Two brass bodies with 1/8" or 1/4" NPT male ports are shown in the foreground.

Special Valve For CFC Recovery

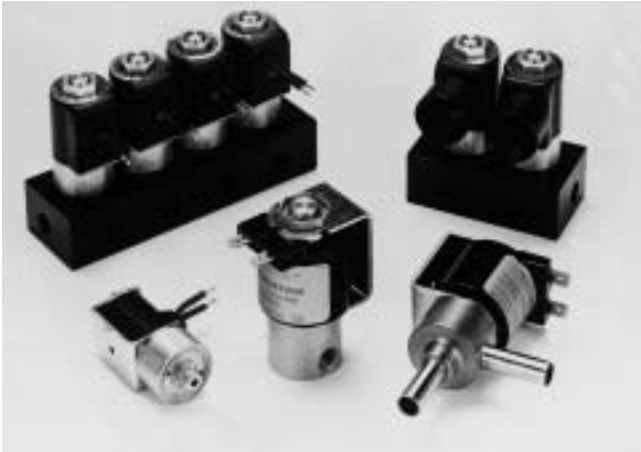

These are some basic valve and manifold combinations we're providing to the refrigerant recovery/recycle equipment market, including Series 50 and Series 20 (center and lower right) valves. Our built-in back pressure design on some models gives us a leg up by helping to eliminate possible refrigerant leakage to atmosphere during HVACR system servicing.

Specifications: The Most Common Peter Paul Solenoid Valves For Refrigerant Applications

	Series 20 With Back Pressure	Series 20 Without Back Pressure	Series 50
Valve Type	2-Way Normally Closed	2-Way Normally Closed	2-Way Normally Closed
Orifice Size	5/64	5/64	1/16 or 5/64
Voltage	Any AC or DC voltage	Any AC or DC voltage	5/64: Any AC or DC voltage 1/16: AC or DC voltage
Inlet Pressure	280 psi maximum	300 psi maximum	300 psi maximum
Back Pressure	150 psi maximum	none	none
Power Consumption	12 Watts AC; 9.5 Watts DC	12 Watts AC; 9.5 Watts DC	6.6 Watts AC; 7 Watts DC
Electrical Connections	Spade terminals	Spade terminals	Spade terminals
Body Connections	1/8 NPT pipe ports or copper (sweat) tubing	1/8 NPT pipe ports or copper (sweat) tubing	1/8 NPT pipe ports or manifold mounting
Seals	Neoprene®	Neoprene®	Neoprene®

Stacking Valve Bodies

The Peter Paul manifold configuration involving stacking valve bodies held together with threaded tie rods is designed for multiple solenoid valve operation and greater flow capacity. Utilizing a standard mounting "footprint" for either common cavity or common orifice, these modular manifolds allow the use of either type within the same manifold. Most importantly, the common flow path through the manifold has been increased almost 700% providing unrestricted flow for quicker response times.

This do-it-yourself building block manifold is widely used in the emission analyzer and gas processing fields. The new style modules are 90% machined and drilled from bar stock. Each module can be in a center or end position in the manifold. A common, pre-drilled port connects all modules in the stack: the finish drilling of each valve module determines the flow pattern through the manifold. It is now possible to mix and match these valve bodies with only minor drilling operations to meet an individual user's application requirements.



Type Available:	Grommet, Conduit, Spade Terminal or DIN Type
Coil Options:	Molded and Non-molded
Series Available:	15 & 50
Orifice Sizes:	Refer to Series 15 or 50
Porting:	1/8" NPT
Pressure Rating:	Refer to Series 15 or 50

Stacking valve bodies for Series 15 and 50 solenoid valves consist of passivated 303 stainless steel or anodized aluminum bodies. These components can be assembled in either outboard or center locations within the modular manifold using threaded tie rods.

Food-Grade Valve Applications



NSF approvals have been received for the Series 15, 20, 30, 50 and Series 70 valves.

Our new NSF approvals allow most of our complete product line to be used in food grade applications, including Series 15, 20, 30, 50 and Series 70 valves. Consult factory.

NSF criteria C-2 covers sanitation requirements for equipment and/or devices used in storing, preparing, or handling foods and beverages. FDA guidelines are for non-metallic material that comes in contact with food-type media. The seal materials that meet FDA's requirements are FLUOREL and SANTOPRENE®. Fluorel is used where higher temperatures exist.

Making Kalrez® Seals Affordable For Volume Valve Applications



We have developed a new and significant cost saving procedure for laser cutting Kalrez® seals from sheet stock for solenoid valve plunger assemblies. Previously (and difficultly) molded seals requiring more than double the amount of Kalrez have now been replaced by a Kalrez seal disc and stainless steel seal cup which are press fit into the plunger. Shown here, clockwise from left, are the new seal cup, seal, and plunger; a Series 52 solenoid valve plunger assembly complete; and a typical molded Kalrez seal from a previous solenoid valve design.

Kalrez® Perfluoroelastomer seals, a product of DuPont Dow Elastomers, are impervious to more than 1,600 chemicals and solvents, inert to most chemically induced swelling, useful in temperatures from -20°F to 600°F, and last much longer than other elastomer seals. Kalrez is also a very expensive design material, even in medical and chemical resistant applications for which no other seal material is nearly as durable.

We have been using Kalrez for solenoid valve plunger seals in applications where nothing else would do. These molded Kalrez seals often more than doubled the price of comparable valves incorporating other elastomer seals.

We have developed a procedure for laser cutting Kalrez seals from 3" square sheet stock. We've now been able to cut the amount of Kalrez used per seal by about half, reducing the cost per seal, even in relatively small quantities, by about 40-60%." Currently limited to 3/32" and smaller orifice sizes, the valve plunger assembly has been slightly modified to use a stainless steel seal cup to attach the Kalrez seal to the plunger. The use of the seal cup actually governs the plunger length better, and two tiny notches on the seal circumference allow the seal to vent gases from within the plunger. The result: A bubble-tight seal for the most difficult chemical applications, without the use of Teflon. "It's an elegant solution to an expensive problem."

Swell-Resistant Printers Gum Seals

We've worked a special elastomer for use with water-based printing inks. We think of ink as being almost benign, but sometimes it can be rather aggressive to certain materials, and swelling of the rubber typically causes a big problem in the dispensing valves for ink.

Peter Paul has worked with our existing rubber supplier on a specific material for ink that was originally developed for the rubber stamp industry and the automatic mailing label industry. If a rubber stamp were to swell up, the lettering and logo would become distorted...so we've come up with a special material: We've developed an elastomer with customized nitrile rubber and very unique for the printing industry. We

started supplying this in conventional plungers and disk compensated plungers, and we're now starting to supply it in media isolation diaphragms for ink dispensing and retrieval systems, some in high-speed ink jet printers.

Commercial ink jet printers do things like posters and large billboards. They fire all the ink jets at one time and deflect them so they have to practically vacuum away the ink that isn't used. Some of these inks are magnetic so the media isolation valve is really the only way to control the flow of these inks. We found that while a number of diaphragm materials are useable, we picked a specific material for the water-based ink printer. It seems to mold well in existing tooling and is relatively



Normal elastomers and printing inks can sometimes combine to cause swell and hence distortions in the printing industry. So we investigated.

economical in cost, seeming to perform fairly well for the water-based inks. This product is currently available in Series 50 and Series 20 size in the diaphragm media isolation valves.



Solenoid Valves For Low Temperature Applications

Our solenoid valves, those precision electro-mechanical "switches" required to perform millions of unattended cycles in applications ranging from coffee vending machines to metal cutting machine tools, are also widely employed at low temperatures to about -40° C involving gaseous and liquid compounds including refrigerants and liquids nitrogen.

For these uses, the full range of our 2- and 3-way valves can be specified with the Teflon® or Kel-F seals required for processing semi corrosives; typically, all valve parts must be oxygen cleaned to remove oils and other surface contaminants. In many such applications, a compressed liquid is metered by the valve. Many of these valves will be UL recognized and CSA listed.

We can provide a wide variety of solenoid valves and manifolds, if required, for low temperature operation involving refrigerants of liquid nitrogen.

EPDM Seals

Special EPDM (Ethylene Propylene Diene Monomers) solenoid valve seals are used for applications where high-pressure gases tend to be absorbed in standard rubber seals.

When gas is absorbed into a rubber solenoid valve seal, it doesn't normally cause any physical degrading of properties but will cause the rubber to display a phenomenon called explosive decompression. If the system were to be vented or pressure reduced, gas that is trapped inside the rubber tends to cause the seal to balloon and swell, sometimes actually fracturing. Users in the fire extinguisher field, for instance, find that rubber swelling over a period of time may actually causes the fire extinguisher valve to shut off.

Used in place of conventional seal materials, such as urethanes, EPDM is more suitable for specific, hard-to-fill applications such as high-pressure gases used in aerospace projects.



Solenoid valve plunger travel stroke is typically 0.020 to 0.050 in., depending on orifice size. Choosing the wrong seal material could literally shut off the valve flow. Notice the swelling in the seal at right.

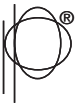

Added Moisture Protection Available For Series 50 Explosion-Proof Solenoid Valves

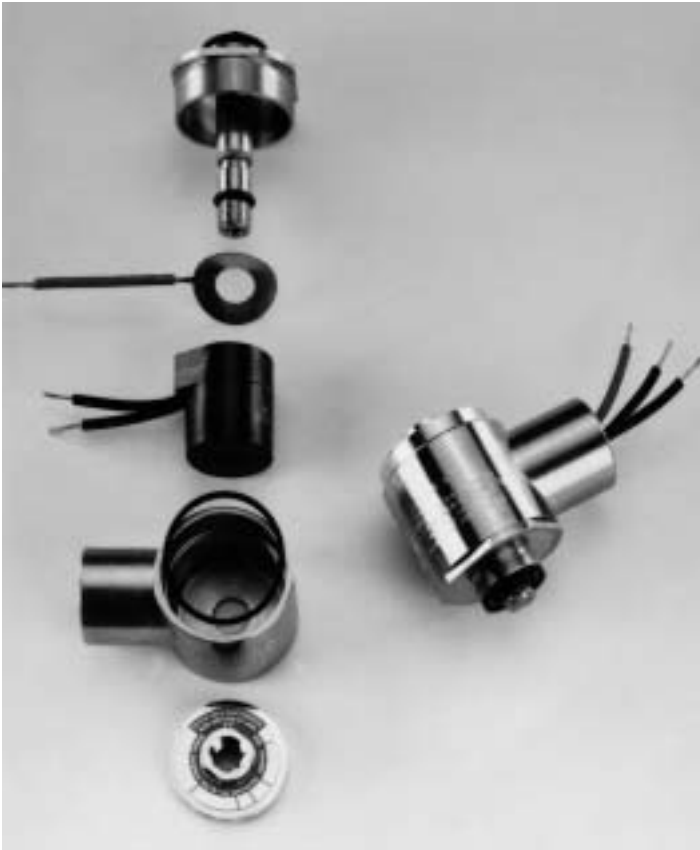

Our Series 50 Explosion-Proof solenoid valves and operators with molded coils for hazardous locations are now offered with added protection from moisture in the form of new O-ring and flat gasket fluorocarbon elastomer seals. The locations of these new seals are shown in the explode view of a coil for an E50 valve (inset).

Added moisture protection provisions for E50 and low watt EL50 and ELL50 miniature Explosion-Proof solenoid valves are now available for Explosion-Proof valves with molded coils requiring added protection from moisture may now be satisfied with new fluorocarbon elastomer O-ring and flat gasket seal to further protect the coil from any possible moisture contamination. While redundant for all but the most arduous process uses, these added seals will still provide a solenoid valve at somewhat lower cost than one with a fully potted coil, top and bottom seals, and an RTV conduit seal.

Designed to meet today's demands for economy of space and energy consumption in hazardous locations, our E50/EL50/ELL50 miniature Explosion-Proof solenoid valves are offered in seven basic designs, based on maximum operating pressure differential, orifice size, CV factor, and operating media. Built to UL standards for safe and continuous operation at maximum rated pressures, the specifications for these general purpose of safety valves for pneumatic and hydraulic applications are conservatively rated at 85% of rated voltage and maximum pressure. In addition to air and other fluids compatible with standard Buna N seals, these valves operate in hot water, steam, gasoline, oil, refrigerant, hydraulic fluid, and other environments requiring special seal materials. Explosion-Proof design with 1/2 NPT conduit connection and stainless steel construction allows these valves to meet the requirements of hazardous locations Class I, Group C and D, and Class II, Group E, F, and G.



FKM Seals Developed For Gasoline And Propane Valve Applications

Today's alternative powered vehicles and reformulated gasolines are causing increased occurrences of solenoid valve seal swelling and cracking in service. This has created the need to reformulate existing FKM compounds to maximize their properties in reformulated gasolines which have significant amounts of MTBE and alcohol.

Additives also have been causing problems with seal integrity, frequently in propane-powered vehicle applications. These fuel applications involve seal swelling with existing standard fluorocarbon elastomers, generically called FKM, but available with trade names such as FKM and Fluorel. We discovered that, by maximizing the fluorine content of their FKM, the swelling was reduced. Further enhancement of the physical properties was made by removing the traditional colorant and adding carbon black. Therefore, the normal color of this new FKM is black.

We see more and more FKM problems in vehicle applications involving solenoid valves, both gasoline powered and alternative fuels (e.g. propane). In some states, reformulated gasoline can be up to 15% MTBE, causing problems with traditional FKM systems. Swelling and rubber decomposition appear with time. Beyond vehicular applications, other related uses, particularly in the medical field, have shown to be more stable and long-lasting when the new FKM is applied.

Solenoid Squirt Valve



Peter Paul Squirt valves Series 15 (left) and Series 50 (right) are part of a family of Squirt valves for process industries and special applications. This valve was originally developed for marking a continuous web of cloth, paper, wood or anything moving on a conveyor which needs to be marked.

Our new Squirt valve is an in-line, two-way Normally Closed Series 50 or 15 solenoid valve with double plunger seal which does not allow continuous flow, but will shut off, energized or de-energized. This prevents a continuous flow condition if someone accidentally left the Squirt valve "on". You get one squirt or drop and no more.

Its main claim to fame is probably its size, currently 50 and 15 solenoid valves with a variety of tube sizes which control drop size. Low pressure ratings of two psi to ten psi are available; anything less than two pounds pressure does not provide enough velocity for a good squirt or drop.

Because this valve was originally developed for marking cloth with dye to highlight defects in yard goods, the valve had to meet both small size and low cost requirements. You might call it non-critical dispensing: It doesn't have to be perfectly exact for oil or any light liquid. If you dispense a drop of oil on a bearing before assembling it, the application would be good enough. The same could be suggested with glue, other types of lubricants, sealants...any light liquid dispensed at low pressure in drop increments.

The small dispenser tube is critical only in its diameter and controls drop size and squirt length. The bigger the drop, the shorter the carry.

These mostly stainless steel versions are available in either AC or DC.

Metering Adapter Adds To Utility Of Our Series 20 And 30 Solenoid Valves



Adjustable, stainless steel metering adapters shown mounted on our (left to right) Series 30 grommet valve, Series 30 conduit valve with in-body metering, Series 20 Explosion-Proof conduit valve, and Series 20 with spade terminals and in-body metering.

A new, adjustable, stainless steel metered adapter for Series 20 and 30, 2-way N.O. and 3-way solenoid valves provides a manually adjustable flow control to a valve which creates a speed control for the process the valve is controlling.

While our solenoid valves can be configured with metering in the valve bodies, the use of metering in the sleeve port adapter on either the top inlet or exhaust allows the user to set the best possible flow parameters for the specific application. For instance, to restrict the return speed of a cylinder, the metering adapter acts as a damper on the process. With the use of these adapters, it is also possible to pipe the exhaust from the solenoid valve out of the area rather than exhausting directly to atmosphere. The metering adapters are available for either 1/8 NPT or 1/4 NPT porting and are used for liquid and gaseous media.

The metering adapter is typically used as a metered exhaust for 3-way normally open valves, or as a metered normally open port in multi-purpose or directional control valves.

Universal Mounting Bracket Now Available For Peter Paul Solenoid Valves



Our new universal mounting bracket is shown here attached to (left to right) Series 15, 30, and 50 and 70 solenoid valves. The zinc plated, carbon steel bracket (foreground) is provided with screws.

The bodies of all our solenoid valves offer an underside pair of drilled and tapped holes for easy mounting. But where the mounting surface is very thick or physically inaccessible, a simple top mounting is desirable.

For such applications, we have developed a universal, plated steel mounting bracket, part number B96, for individual, solenoid valves in Series 15, 20, 30, 50, and 70. Provided with screws and several countersunk hole configurations, the brackets are easily installed and may be used in virtually any operating environment.

Manual Override Now Offered On Many Peter Paul Solenoid Valves



Manual override (turn-lock or momentary push button) is a factory option and is available on specified solenoid valves including (clockwise for 10) Series 20, grommet housing, multipurpose; Series 70, conduit housing, 3-way NO; and Series 58, DIN-type connector, 3-way NC.

Manual override, a mechanical device which permits the momentary or locking manual opening of NC valves or the closing of NO valves, is available as a factory option on many models of our Series 58, 20, and 70 solenoid valves.

There are a number of common processing situations in which it may be necessary to actuate a single solenoid valve in a array of valves without disturbing the electrical sequencing or piping to these valves. The manual override option is built into the bodies of these valves and will not affect their normal operation unless actuated in the case of power failure or similar circumstance.

The manual override option adds only marginally to the cost of the valve; other body options, as you know, include metering, metered bypass, manifold mount, flange mount, and orifice metering.

Screw-In Series 20 Solenoid Valve Bodies Offered With Larger Ports



New, brass, and stainless steel screw-in, Series 20 solenoid valve bodies offering simplified assembly, disassembly, and field replacement are now produced with enlarged ports for higher flow applications.

The Series 20 screw-in valve bodies speed and simplify valve-to-manifold attachment in processes involving liquid or gaseous media compatible with brass. Assembled barely more than finger tight, these brass bodies incorporate two O-rings to help eliminate leakage and provide the required high burst pressure ratings. These bodies are offered for use with brass, stainless steel, or anodized aluminum manifolds where media compatibility is not a problem.

These unique, screw-in valve bodies (1/2-20" male UNF-2A port) are available for many of our standard valve models and are used for both conventional, one-piece machined manifolds of with out proprietary modular solenoid valve building block manifolds.

Our large port, screw-in, Series 20 valve bodies for simplified manifold mounting are now offered in brass for compatibility with a broad range of liquid and gaseous process media and with existing brass, anodized aluminum, and stainless steel manifold designs. Dual O-rings in these screw-in valve bodies virtually eliminate the possibility of leakage and provide attractively high burst pressure ratings.

Unique Solenoid Valve Indicates The Location Of Track Flaws For The Railroad Industry



The complete Series 30 spray valve used to mark suspect areas of track for subsequent inspection and repair incorporates a unique lower nozzle section which is removable for cleaning of all parts that come in contact with the oil-base paint which is dispersed by the valve. The valves are part of automated testing systems used by independent rail testing services.

We have developed a special, two-way, Normally Closed solenoid valve used by rail flaw inspection services to pinpoint track problem areas for the railroad industry. Designated the Series 30 spray valve, this 12 VDC, 8 watt, 60 psi valve is part of an ultrasonic or induction detection system used by independent rail testing service organizations for checking each rail, end-to-end, to automatically identify faults, cracks, and railhead (wear) loss. When a flaw is found, the solenoid valve is automatically energized and a yellow, oil-based paint is pressure sprayed through the adjustable valve nozzle, marking the defective area for subsequent identification and repair.

Paint flow is straight through the valve from the adapter on top to the nozzle-like bottom of the brass body, which incorporates a 7/64" orifice. The nozzle portion of the valve is removable so that all of the internal parts, including the nozzle, can be cleaned to prevent clogging. In addition to marking track areas for manual inspection and repair, the track riding test vehicles provide their operators with a visual display of track anomalies including cross-sectional views and realhead wear diagrams and retain these data electronically for off-line analysis and report generation. The design of the Series 30 spray valve has been tested in several similar applications, with particular emphasis on O-ring and seal compatibility with the material being discharged.

High Flow Valve



Low pressures, high flows, compact size, larger flow passages...that's what's cooking with commercial cookers.

Here's a solution to provide a Series 30 Normally Closed valve for LP and natural gas...very low pressures up to about 2 psi but with high flows ($C_v = .57$), compact size, and economy in a Series 30 valve. As you can see from the photograph, this style has larger flow passages for higher flows through the valve. Larger drilled ports also allow higher flows. While our competitors provide C_v 's of about .40, they probably use multiple valves on smaller burners with more pressure drop. The seal materials are typically FKM, with brass bodies, yoke, and spade coil, most of the appliance-type. For standard equipment, it had to be basically small and economical. High flow is usually needed for commercial cookers and could be used with any kind of gas-fired heaters. They're also employed for incubators and poultry brooders. And these valves might also be useful for decorative gas-fired lights, infrared heaters, small heaters, patio heaters, and more.

Our valve is a very high flow, low cost unit with compact size.

The same technology would potentially apply to gravity feed systems such as lubricators...low pressure lubrication, low pressure dispensing of various materials from a low pressure valve requiring a large orifice, but overall small in size. Perhaps we could provide some samples for you.

Series 50 with Welded Stainless Steel Fittings



Series 50 Welded Fittings

Designed to meet stringent purity requirements in analysis equipment and other applications requiring all welded components. Available with various options including 3-way operation and diode rectifier coils for quiet operation. Continuous operation at maximum rated pressure. Shown as 3-way with welded stainless steel fittings

It may come as a surprise to learn that about 80% of the product information calls involve special, unique, and non-standard applications for our solenoid valves.

For instance, a customer asked us to modify a standard Series 50, 3-way, Directional Control valve with stainless steel components and FKM seals for oxygen service to incorporate special welded fittings (one tee and one elbow) with threaded ends as shown in the picture.

These modifications of standard Series 50 drawings took a few minutes to complete by CAD. They were immediately faxed to the customer and approved. The result, as you can see to the left, is a valve with relatively simple external modifications which precisely meets the requirements of the user's application. Five easy steps: Request; drawings, mechanical changes; prototype; production.

High Flow Vacuum Solenoid Valves Developed For Medical & Industrial Applications



New line of solenoid valves for sterilizing medical instruments includes a large air-operated valve with extended plunger stroke for high-flow and a smaller valve, 2-Way, Normally-Closed with 12 VDC power.

We have developed a new series of solenoid valves for use in vacuum chambers for sterilizing medical instruments. These valves feature high flows; bubble-tight; standard vacuum fittings and standard flanges for international use; electron beam seamless welding of flange to body; purity requirements allowing no trapped particles on the inner diameter; several million cycle endurance for critical life operation; and Teflon™ outside coating to eliminate dust and possible wear-creating particles.

Two basic models have been developed: The smaller one is electrically operated with 1/2" orifice, 2-Way, Normally Closed with FKM plunger seals.

The larger of the new valves is air-operated by cylinder with a 1" orifice to meet high-flow requirements. The spring-loaded assembly seals on the orifice for failsafe operation. Assembly of this larger unit also involves electron beam welding. Both valves employ anodized aluminum bodies with all stainless steel inner moving parts. Of particular interest to prospective users, a major medical products producer required elaborate testing of valve open/close times, as well as extensive endurance testing.



Cutaway of large, air-operated valve shows 1" orifice.

Stainless Steel Series 58 Solenoid Valves



Two Peter Paul Series 58 valves with stainless steel bodies are (left) 2-Way, NC, stud mount, and coil with lead wires; (right) 3-Way, NC, piped exhaust, 10/32 ports, and coil with lead wires.

Additions to our line of molded Series 58 solenoid valves have been developed with two stainless steel bodies. These bodies supplement the existing six models of plastic valves currently used in portable medical devices, analyzers, portable test equipment, and similar applications.

These stainless steel bodies represent an option for the 58 valves while retaining all the same coil options, voltages, wattages, orifice sizes, pressure ratings, and elastomers.

Two stainless steel models are offered in both 2-Way and 3-Way versions: A stud mount, utilizing a 10/32 stud as the orifice connection and an annular groove as the cavity connection. These connections are separated and sealed with O-rings. The other body style uses 10/32 female ports for both the cavity and orifice connections. Optionally, the user can upgrade from the plastic bodied Series 58 to either of the stainless steel bodies.



Series 50 Valves Configured For Precision Electronic Production Equipment



Two examples of the new, sealed, Peter Paul Series 50 solenoid valves for electronics and chip manufacture are shown. A 24 VDC, 7.0 watt, 1/16" orifice, 100 psi solenoid valve (top) is offered with grommet housing and 1/4" O.D. stainless steel tubing welded to the body; the sleeve assembly is threaded to the body and sealed with an elastomeric gasket. The valve below incorporates welded 1/8" O.D. input/output tubing but with body and sleeve assembly welded together, eliminating the gasket and threads, for total, positive, permanent sealing.

We've announced a new, completely sealed, Series 50 solenoid valve to meet today's stringent requirements for chip manufacturing, analysis equipment, and other types of ultra high purity equipment requiring welded components.

Available immediately in a 2-way, Normally Closed configuration, the valve can be produced in many AC or DC voltages. These Series 50 valves feature all 430F stainless steel construction with either 1/8" or 1/4" O.D. stainless steel welded tubing as their port connections. The sleeve assemblies of these valves can be attached with conventional threads and elastomeric seals or, for the most critical applications, with the body welded directly to the sleeve assembly. Both grommet and conduit-style housings are offered, with internal electro polish available.

Employing all our standard components for millions of trouble-free operating cycles, these fully sealed Series 50 solenoid valves are available with all standard options including 3-way operation, quiet operating diode rectified coils, and more for continuous operation at maximum rated pressures as required.

. . . Special Options

3-Way and 2-Way Solenoid Valves For Quiet (No-Click) Operation

Peter Paul Electronics Co., Inc. has developed solenoid valves for use in medical applications such as hospital beds, breathing apparatus, and inflatable mattresses for burn patients in which a bumper is installed for quiet operation.

In normal industrial applications, the click of a solenoid valve is not an issue, but in the quiet of a hospital environment it can be nerve wracking to hear constant clicking as the valve is actuated. Several new plunger and bumper designs used in the 3-way function have a top seal but eliminate the metal-to-metal contact.

One way to "eliminate the click" is to put in a rigid top seal that's non-compensating and doesn't move. The top seal contacts the end stop, but no metal contact is made. It requires a unique plunger and uses a special end stop to accommodate it. Many times the pressure ratings are reduced just a bit due to the increased air gap in the valve, affecting magnetic performance. Usually these applications are low-pressure air or vacuum, therefore the reduced rating of the valve is generally not an issue.

Rectified coils are also often specified in medical equipment, either full bridge or half bridge, to eliminate the potential for noise. A valve, which might potentially cause a hum or buzz can be very annoying to a patient, so a full wave rectified unit for AC service is often preferred. A DC unit, not requiring a rectifier, is sometimes used in specific applications.

Also common is a bumper in a 2-way valve, usually just a flat disk with no sealing action. Bumpers may be urethane or filled Teflon or special low cold-flow Teflon, which doesn't become deformed like virgin Teflon.

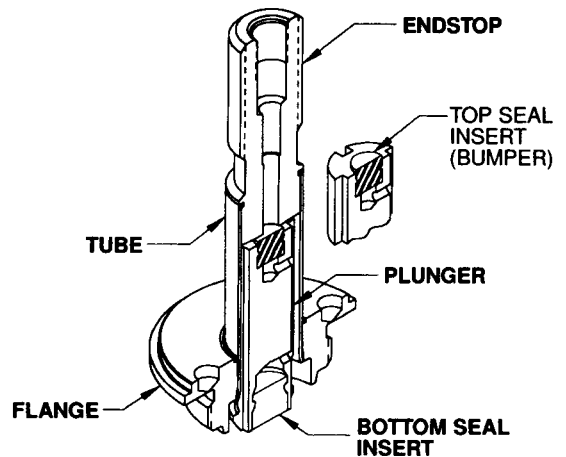

Typical Peter Paul Electronics 3-way and 2-way solenoid valves for use in medical applications such as hospital beds, breathing apparatus, and quiet, no-click operation (shown on cutaway).

Occasionally, a bumper is included in a valve for a non-medical application where long life is critical. With a bit more cost, a Teflon-coated plunger combined with a bumper will provide very long, quiet valve life under many operating conditions.

Diode Rectified Solenoid Valve Coils For Quiet Operation

Most solenoid valves now in operation are powered by AC current, primarily because AC voltages are more readily available. AC solenoids have faster pull-in (cycle) times, with a ratio as high as 3:1 compared to DC power. However, AC or DC powered valves have a natural tendency to audibly “click” at the beginning of each on-cycle and can sometimes, under adverse conditions, emit a low, but audible hum in operation.

While perfectly acceptable for the majority of applications, valves destined for quiet environments, such as hospitals, often cannot accept the possibility of a hum or, in extreme cases, a buzz. Further, in an AC valve, anything that will prevent proper mating of the plunger pole faces, including dirt and corrosion, can cause noisy operation. In addition, AC solenoids, because of the in-rush current and fast cycling, can evidence higher heat rise than would be experienced under steady-state conditions, another problem in hospital/medical/ laboratory applications. The reactance on AC solenoids increases progressively, reducing the current as the plunger moves into its seated position. If the plunger is restricted, the temperature will increase as the square of the current.

All of these inherent AC valve conditions have led us to provide many AC valves with diode rectified coils, allowing the valve to run on DC power for cooler and quieter operation in application where these are required. Fortunately, semi-conductor diodes are considerably less expensive today than in the past, and their use has not caused a significant cost increase where DC operation is necessary.

Operating on DC, the valve plunger need not be seated on its stop in order to prevent coil burnout, and the typical DC solenoid exhibits a longer life because it is not subjected to the peak voltages produced by the more broadly cycling AC current. The closed gap pull force is greater on DC than AC for the same pole area. Normally the AC pull curve has a sharper bend at each peak or valley, while the DC curve is consistently flatter.

Given the many superior properties of solenoid valves with diode rectified coils converting AC input power to DC operation, and the increase in medical-oriented applications where these DC valve capabilities are desirable, we are able to offer most basic solenoid valves with a diode rectified coil to meet specific user criteria. For applications which require it, a 4-diode full wave bridge also is available.



Location of the rectified fly back diode array in DC rectified solenoid valve coil is shown (cutaway). Most of our valves can be so configured, including the Models 50, 20, and 30 (left to right) above, all specified with diode rectified coils for the inherent low noise/low temperature provided by DC operation. They are used primarily for low noise/low temperature quiet locations such as hospitals and laboratories.

Peter Paul Water-resistant Valves for Submerged Operations

Peter Paul Electronics Co., Inc., offers water-resistant solenoid valves featuring a fully encapsulated coil, for applications where exposure to moisture or even complete submersion is necessary.

The Series 15 or 50 valves are intended for a wide range of outdoor uses including HVACR, irrigation systems, off-road equipment, trucks, buses, trains or other vehicles experiencing significant exposure to wet environments, including boat trailers, controls, engine and bilge areas. The valves feature a liquid epoxy potted coil assembly and a rugged housing covered with a baked-on epoxy/polyester finish rated at 1000+ hours in a 5% salt spray test. The potting provides increased heat transfer capabilities through elimination of trapped air pockets for a cooler running valve.

All internal parts are constructed of stainless steel and brass. Corrosion resistant materials are used for exposed parts. The standard version operates on a 12 VDC, single lead power connection. Dual power lead versions can be used for mounting on non-conductive surfaces such as fiberglass, plastic or wood. Additional power options are also available.



Encapsulated Diode Spade Coil For Series 15 Solenoid Valves



A full wave bridge can now be encapsulated into the coil assembly Series 15 solenoid valves. By embedding the required electronics in the coil, a DC valve can be driven by common AC voltages.

Each valve's encapsulated coil contains a diode circuit that converts common 50/60 Hz voltage to DC. Running the coil on DC eliminates the in-rush current associated with AC valves, thus limiting the excessive heat build-up encountered with frequently cycled valves. The use of DC coil voltage also allows the use of an elastomeric damper within the valve itself. This damper reduces the audible click which occurs on actuation as well as increases the life of the valve, for a wide range of hospital and laboratory applications.

Electrical Connectors



These solenoid valves are factory-equipped with the required pin connectors and as-specified leads and lead lengths to allow the installation of valves by maintenance personnel without the need for on-site electrical engineers.

It is recognized that solenoid valves can be configured with numerous coil options, voltages, orifice sizes, pressure ratings, elastomers, footprints, and more. In addition, there are a wide range of attachments and add-ons such as splice boxes, mounting brackets, manifolds, and more to enhance the utility of the solenoid valve.

To provide even more value-added aspects to our valves, these solenoid valves are offered with many electrical connectors, allowing on-the-floor maintenance staff personnel to disconnect and switch solenoid valve connections without the need for an electrical engineer. These electrical connectors include male or female pins and connectors, custom lead lengths, junction box connectors, and other simple fasteners which can be handled on the plant floor or in the field. Typical electrical connectors include pin styles, receptacles, housings, flag connectors, and two- or three-pin flange connectors. While the add-on costs of these pins and connectors are nominal, their inclusion at the factory make the solenoid valves of which they are a part installation-ready as received by the user.

Time Delay Coils Check Process Before Media Flow

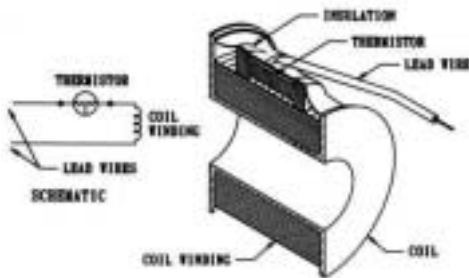

This time delay coil with built-in thermistor (cutaway) is at the heart of the Peter Paul Series 30 solenoid valves employed on many oil burners.

Time delay coils with built-in thermistors have been developed for our Series 30 solenoid valves. The thermistor circuit in the solenoid valve coil delays the pick up of the valve's plunger from 2 to 6 seconds. This allows the solenoid to be certain of the required process parameters before media flow commences.

A common example is the start-up sequence for an oil burner. It is vital that a sensor in the furnace's electrical circuit "sees" that a flame has been generated to continue the flow of fuel oil. If there is no flame, oil flow may flood the burner, often requiring maintenance of an extended period of time before a re-start can be initiated. When the call activates the burner, the solenoid valve's time delay function allows the pump and fan/motor to reach operating speed before starting fuel flow.

Series 30 solenoid valves, UL recognized and CSA listed, are frequently used in these boiler and furnace applications because of their economical pricing and compact size.

Dual Voltage Solenoid Valve Coils



Dual voltage, four-wire coil and completed dual voltage solenoid valve (Series 20, left and Series 50, right) are used when two voltages may be involved in a process, typically 120/240 VAC or 240/480 VAC.

For many small AC motor applications including powered hand tools, it has become quite common for the motors to be configured to operate at one of two voltage levels, typically 120/240 VAC-60 Hz OR 240/480 VAC-60 Hz.

Now for the Series 20, 50, 60 and 80, 2-, 3-, and 4-way solenoid valves, we can provide dual voltage coils to allow the solenoid valves to be wired for either of the applicable voltages, reducing parts inventory and product installation / assembly at the distributor, OEM, and end user locations.

For specific applications in which more than one voltage might be encountered, the dual voltage solenoid valves are identical to their single-voltage versions except for the additional coil windings and leads.

Series 58 Super Sub-Miniature Coils

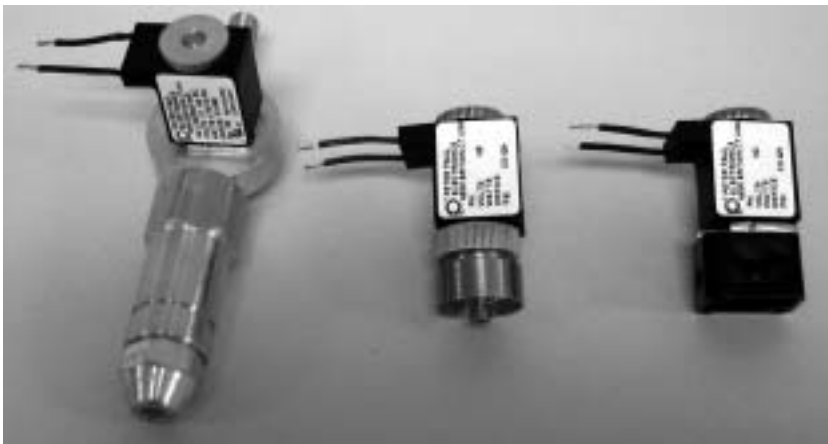

These coils were specifically designed for small places. The Sub-Miniature coil mounts on our existing Series 58 Bodies, ie Stainless Steel Screw-In or 10-32 Ports and our standard plastic bodies, Manifold Mount or 10-32 Ports. These valves are ideal for micro electronic production equipment and medical or chemical analytical applications where space is limited. Also, can easily be suited for any value added OEM application, as shown with special brass fittings and accessories. Consult factory for size, pressure ratings, orifice sizes and power requirements.

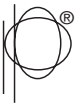

Splice Box Option Allows Field Wiring For All Peter Paul Conduit-Style Solenoid Valves

An optional, 2-3/16" x 1-25/32" x 1-1/2" splice box housing has been announced by Peter Paul Electronics Co., Inc., New Britain, Connecticut, to allow field wiring directly to any Peter Paul conduit-style solenoid valve.

Designed to save a conduit run and remote connection box, the copper brazed steel splice box offers three, standard, 7/8" diameter knockouts to provide wiring access from different locations. Solenoid valve coil leads are 6", #18 wire; a ground terminal screw is provided inside the box. Optional wall or panel mounting brackets may also be specified as required.

Any standard Peter Paul Series 20, 30, 50, or 70 Series solenoid valve can be mated to the splice box, which will be UL listed for use with UL listed valves.



The splice box housing option, shown here with a variety of Peter Paul solenoid valves, provides space for multiple wiring hookups, three 7/8"

Splice Box Option Allows Field Wiring For Peter Paul Solenoid Valves

An optional, redesigned and streamlined splice box, with either conduit box or configuration for Romex open wiring, has been announced by Peter Paul Electronics Co., Inc., New Britain, Connecticut, to allow field wiring directly to any Peter Paul Series 20 (stainless steel) or Series 30 (brass) solenoid valve.

Designed to save a conduit run and remote connection box, the more universal splice box allows quick and inexpensive field wiring connections to the valve. Any standard Peter Paul Series 20 or 30 solenoid valve can be mated to the splice box, which is UL listed for use with UL listed valves.



Splice Box option for Peter Paul Series 20 (stainless steel, left) and Series 30 (brass, right) solenoid valves provides space for multiple wiring hookups and an easy access cover for quick and inexpensive field wiring connections directly to the solenoid valve. Splice Boxes shown here with user-provided wire connectors.

MISCELLANEOUS OPTIONS

SEAL MATERIAL

Peter Paul Electronics offers a large selection of optional seal materials. Standard seal material for catalog valves is nitrile elastomer, a good general purpose compound, satisfactory for most applications. Insert materials such as FKM, Nordel, KeL-F®, and Teflon® are available for applications where excessive heat is a factor, or for use with any media that can cause insert swelling or deterioration. Consult factory for proper usage.

COLOR CODED
SEAL INSERTS

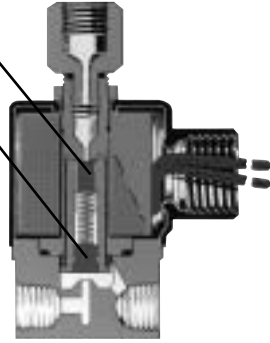

Trade Name	Color Code
Hypalon®	Green
Kalrez®	Black
Neoprene®	Red
Neoprene®	Black
Nylon®	Opaque
Teflon®	White
Urethane®	Yellow
FKM	Brown
Santoprene®	Off-White
KEL-F®	Opaque
Nitrile (Buna N)	Blue
Nordel	Gray
Silicone	Red

UNIVERSAL MOUNTING BRACKET

“The Flat Mounting bracket”

Series 20, 30, & 50 valves can be secured to bracket using tapped hole in bottom of valve body. Order Part No. 20-2416.

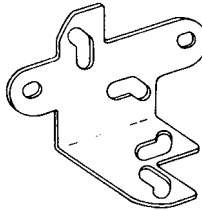

OPTION A — ALUMINUM SHADING RING

Used on valves where media is harmful to standard copper ring, but will not attack aluminum rings.

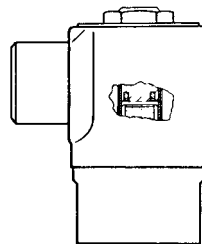

OPTION S — SILVER SHADING RING

Used on valves where media is harmful to standard copper ring, but will not attack silver rings.

OPTION V — BUILT IN MUFFLER

Compact muffler located in valve outlet port to silence excessive noise. Muffler location will vary according to valve type — 3 WNC Valve Muffler in sleeve exhaust port, 2 WNC Valve Muffler in body outlet port, etc.

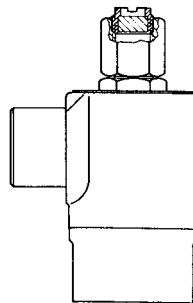

MANIFOLD MOUNTING Option “E”

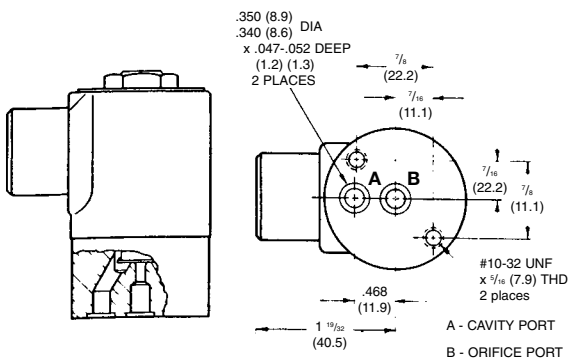

FLANGE MOUNTING Option “H”

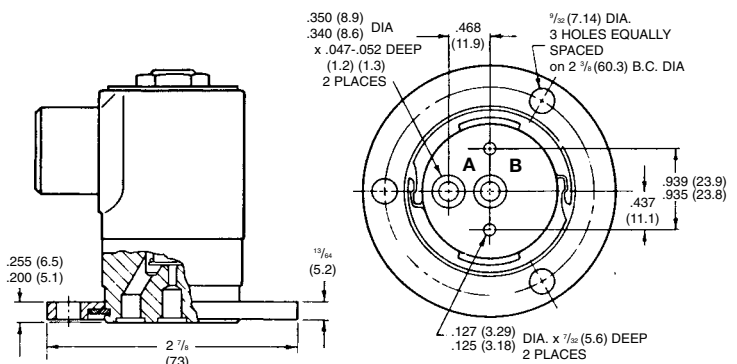

FILTERS & MUFFLERS

INLINE FILTERS FEATURE:

- RUGGED ALL-BRASS CONSTRUCTION
- 1/8 & 1/4 NPT SIZES
- AVAILABLE IN 20, 40, 60 & 100 MICRON RATINGS

FILTER/STRAINERS FEATURE:

- RUGGED ALL-BRASS CONSTRUCTION
- 1/8 NPT CONNECTIONS
- 43 MICRON STAINLESS STEEL SCREEN
- EASY SERVICE WITHOUT DISTURBING FLUID CONNECTIONS

EXHAUST MUFFLERS FEATURE:

- RUGGED ALL-STAINLESS CONSTRUCTION
- SINTERED STAINLESS MUFFLER ELEMENT
- COMPACT DESIGN — LOW PROFILE
- 1/8 & 1/4 NPT SIZES
- LOW NOISE LEVEL
i.e., Exhaust noise of 3WNC Valve at 100 psi and 200 CPM reduced from 99dBA to 75dBA (measured at 3 feet from Muffler)
- CAN BE USED AS BREATHER VENT FILTER



All Peter Paul filters and mufflers are designed for maximum flow with minimum restriction and are compatible with all common media not reacting with brass or stainless steel.

PRODUCT NUMBER CHART				
DESCRIPTION	PART NUMBER	PIPE SIZE	MICRON SIZE	MATERIAL
INLINE FILTER	F520-A	1/8 NPT	20	BRASS
	F540-A		40	
	F560-A		60	
	F5100-A		100	
	F620-A	1/4 NPT	20	
	F640-A		40	
	F660-A		60	
F6100-A	100			
FILTER/STRAINER	S543-A	1/8 NPT	43	BRASS
	S5140-A	1/8 NPT	140	
MUFFLER	M875-C	1/8 NPT	75	430F SS 430F SS
	M975-C	1/4 NPT	75	

EXAMPLE: Inline Filter 1/4 NPT 60 Micron Brass Body No.F660-A

FILTER/STRAINER

The Peter Paul Filter Strainers are designed for the customer who needs efficient filtration of large contaminating particles along with ease of servicing. The 43 Micron screen has a large filter area and can be cleaned without removing the filter body from the system.

SPECIFICATIONS:

Pipe Size: 1/8 NPT $C_v = .23$
Screen Rating: 43 Micron or 140 Micron
Max. Working Press. Diff.: 300 PSI
Burst Press.: 4000 PSI
Temp.: -40° to +200°F
Materials: Brass Body & Filter Hsg., Stainless Strainer & Flange Cap
Buna N Seals
Media: All non-corrosive liquids & gases

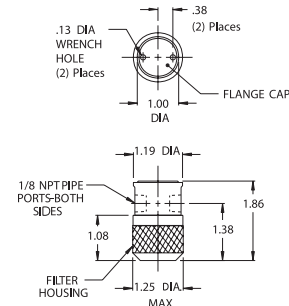

INLINE FILTER

The Peter Paul Inline Filters are designed to be a convenient "last chance" filter which provides maximum protection for all fluid power devices. Female/Male pipe threads are provided for ease of installation. Available in four micron ratings.

SPECIFICATIONS:

Pipe Size: 1/8 or 1/4 NPT
Micron Rating: 20,40, 60, or 100
Max. Working Press. Diff.: 300 PSI
Element Burst Press. Diff.: 1500 PSI
Temp.: -40° to +300°F
Materials: Brass Body with sintered Bronze Filter Element
Media: All non-corrosive liquids & gases

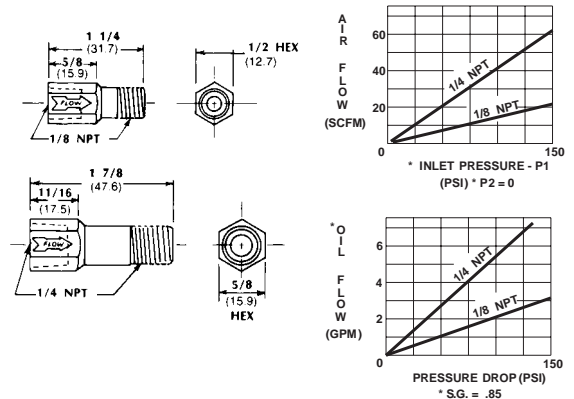

EXHAUST MUFFLER

The Peter Paul Exhaust Muffler is designed for use with air cylinders and control valves or wherever excessive noise due to exhausting air is a problem. These mufflers will fit into any 1/8 or 1/4 pipe port and will reduce exhaust noise substantially, yet will not cause excessive restriction.

SPECIFICATIONS:

Pipe Size: 1/8 or 1/4 NPT
Max. Working Press. Diff.: 400 PSI
Element Burst Press. Diff.: 4000 PSI
Temp.: -40° to +300°F
Materials: Stainless Steel Body with Sintered Stainless Element (75 Micron)
Media: Air and most gases

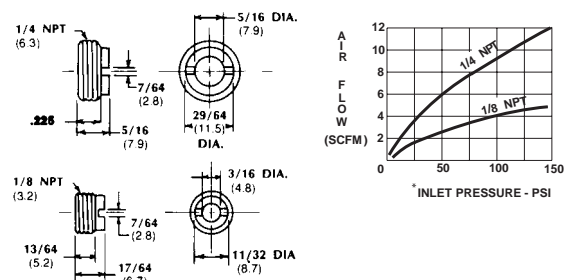

HOUSING OPTIONS Constructed of stainless steel, plated and painted steel. Styles include strain relief connector, single automotive, double automotive, AN connector, splice box, yoke, conduit, grommet, bracket, JIC housing, potted coil & housing.

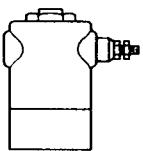

SERIES 20 & 30
OPTION AS
AUTOMOTIVE TERMINAL
SINGLE

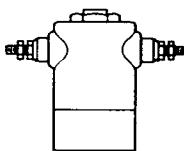

SERIES 20 & 30
OPTION AD
AUTOMOTIVE TERMINAL
DOUBLE

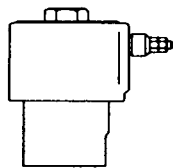

SERIES 70
OPTION AS
AUTOMOTIVE TERMINAL
SINGLE

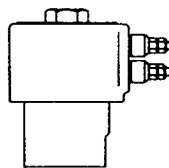

SERIES 70
OPTION AD
AUTOMOTIVE TERMINAL
DOUBLE

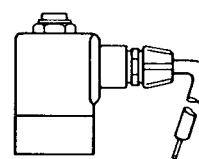

OPTION Q
STRAIN RELIEF CONNECTOR
SUPPLIED WITH SJT LEADS

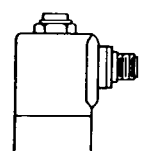

OPTION S
"AN" CONNECTOR

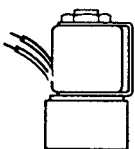

OPTION Y
MAGNETIC YOKE

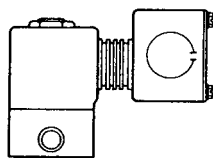

OPTION N
SPLICE BOX

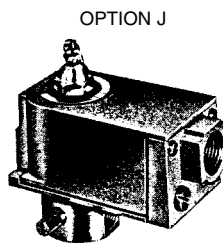
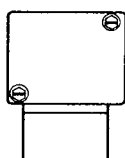

OPTION J

J.I.C. HOUSING (SERIES 20 ONLY)

When additional solenoid protection is required, Peter Paul's J.I.C. Enclosure may be applied. In addition to meeting J.I.C. Standards, this unit fulfills requirements for many NEMA Types. See listings in column at left. Maintenance is simplified, because removal of electrical conduit is unnecessary upon unit disassembly. Available with pigtail wire in Peter Paul Solenoid valves or in Peter Paul valve operators for OEM application.

BRACKET DIMENSIONS FOR ALL SERIES

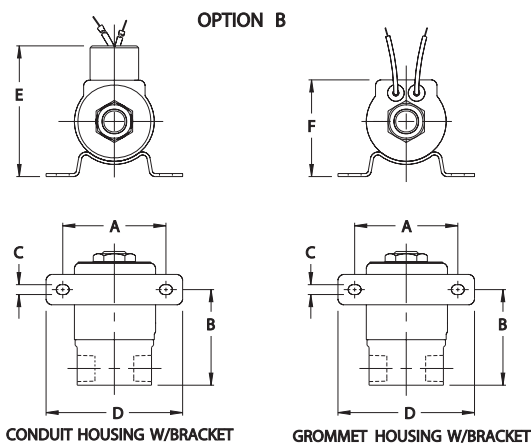

INCHES

SER.	A	B	C	D	E	F
20	2.13	1.97	.20	2.81	2.67	1.98
30	2.13	1.53	.20	2.81	2.67	1.98
50	1.50	1.53	.19	1.94	1.88	1.34
70	2.75	2.44	.20	3.44	3.31	2.61

MILLIMETERS

SER.	A	B	C	D	E	F
20	54	50	5.2	71.3	67.9	50.4
30	54	38.9	5.2	71.3	67.9	50.4
50	38.1	38.9	4.8	49.2	47.6	34.1
70	69.8	61.9	5.2	87.3	84.1	66.3

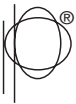

COIL OPTIONS Besides coils ranging from 1.5—1150 volts AC & DC, the construction varieties are: non-molded, molded, high temperature, potted coil & housing, diode rectified coil, third wire ground, and spade terminal coil.

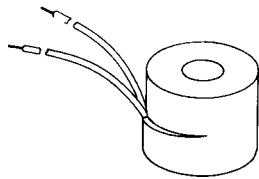

OPTION M — waterproof molded coil—class F (155°C) rating. Coil completely molded in epoxy for maximum moisture resistance.

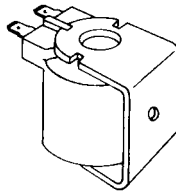

* **OPTION KM** — molded spade terminal coil and yoke—epoxy molded coil with two ¼ spade terminals for quick assembly and disconnect.

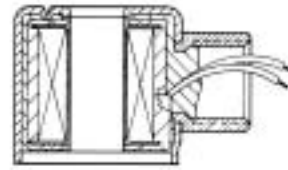

OPTION P — coil epoxy potted into housing—offers max. moisture and vibration resistance. Meets UL raintight & rainproof housing requirements and NEMA—4 Classifications.

* NOTE: Height of valve increases with Spade Terminal option—see drawings below

VALVE BODY DIMENSIONS-SPADE TERMINAL COILS

SERIES 20

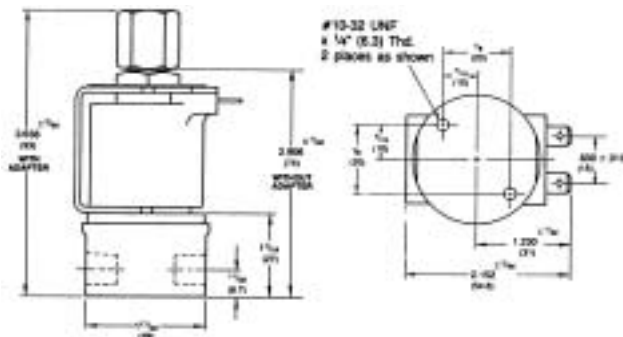

SERIES 30 3-WAY VALVE

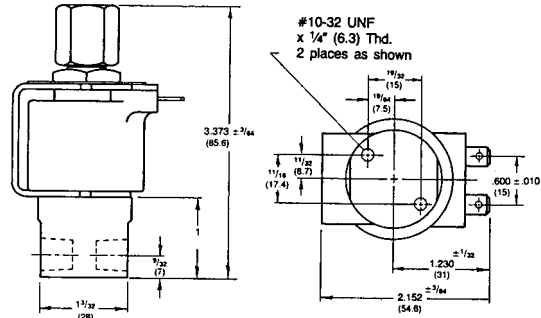

SERIES 50

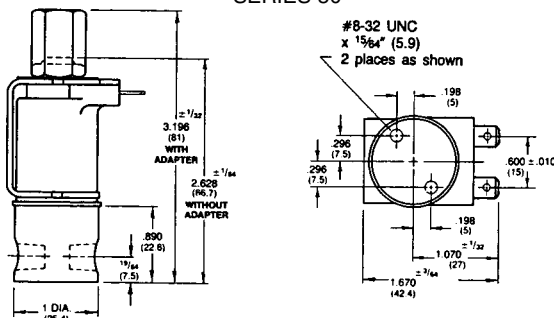

SERIES 30 2-WAY VALVE

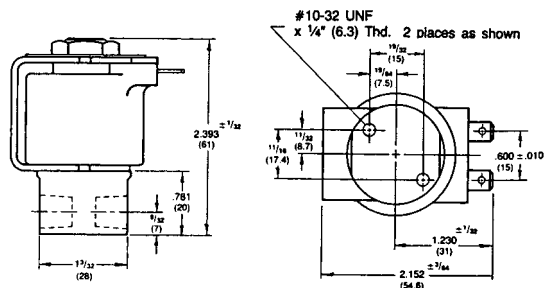

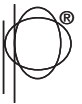

SOLENOID VALVES . . .

BODY OPTIONS Built of stainless steel, brass, anodized aluminum, nylon, and other plastics. Manual override, metering, metered bypass, manifold mount, flange mount, 90° port left & right, orifice metering, and some other special options.

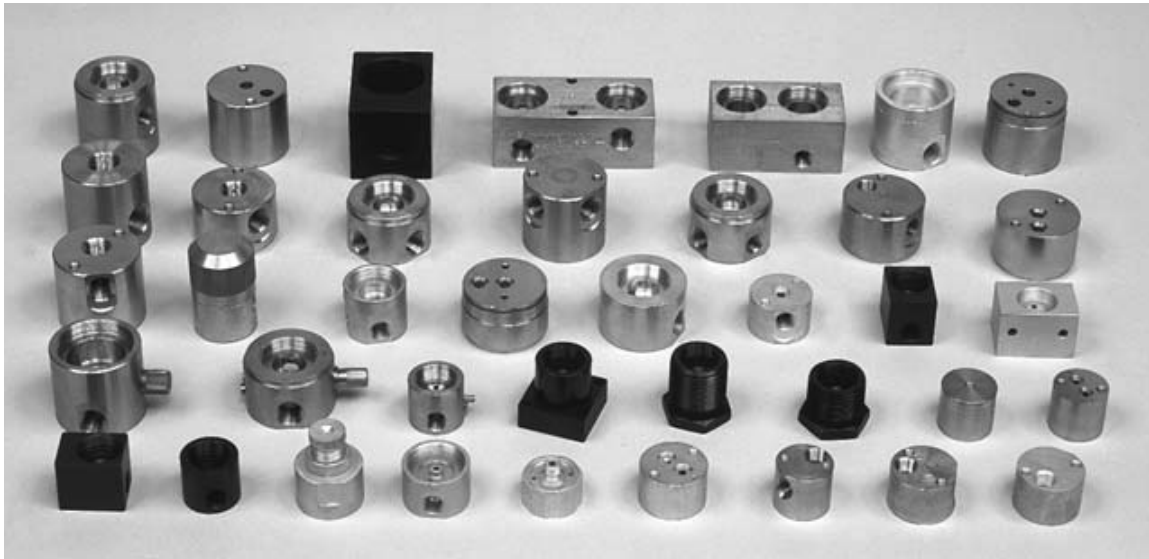

FLOW ADJUSTING OPTIONS

Series 20 & 30

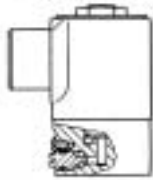

OPTION T – METERING of $\frac{3}{64}$ - $\frac{1}{8}$ ORIFICE VALVES

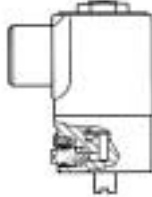

METERING of $\frac{1}{32}$ - $\frac{1}{8}$ ORIFICE VALVES

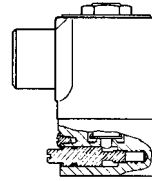

OPTION F – METERING SERIES 20 $\frac{3}{32}$ - $\frac{1}{4}$ ORIFICE SERIES 70 $\frac{3}{32}$ - $\frac{1}{4}$ ORIFICE

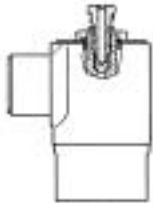

OPTION U – FLOW METERED AT EXHAUST PORT OUTLET

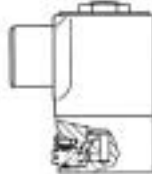

OPTION W – METERED BYPASS



OPTION Y – MANUAL OVERRIDE – VALVE MAY BE OPERATED MANUALLY BY ROTATING STEM 90°

AVAILABLE LOCATIONS FOR FLOW ADJUSTING OPTIONS

2WNC	2WNO	3WNC	3WNO	DIR. CONTROL	MULTI-PURPOSE
<p>Metered outlet port</p>	<p>Metered inlet port</p>	<p>Metered inlet port</p>	<p>Metered exhaust port</p>	<p>Metered normally closed port</p>	<p>Metered normally closed port</p>
STANDARD VALVE BODY'S ORIFICE METERED—OPPOSITE SIDE AVAILABLE ON REQUEST					

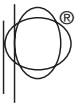

PORT OPTIONS

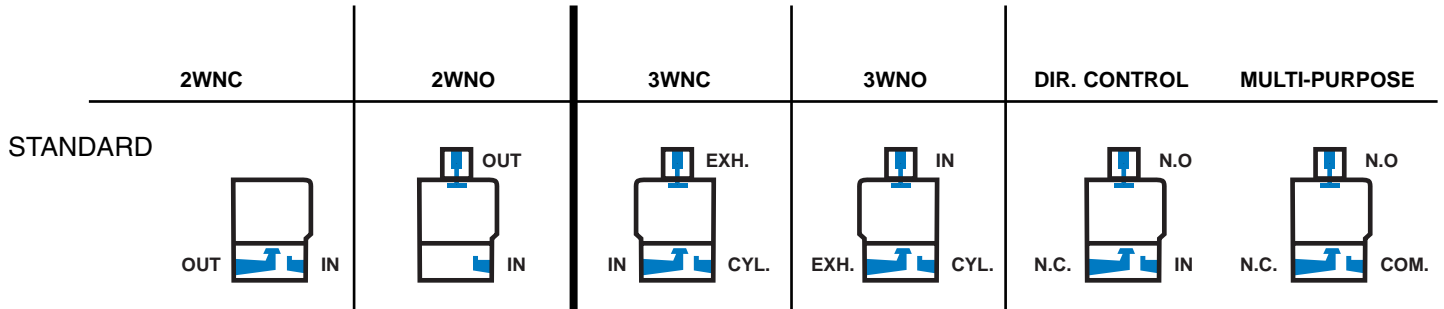

IN-LINE PORTS

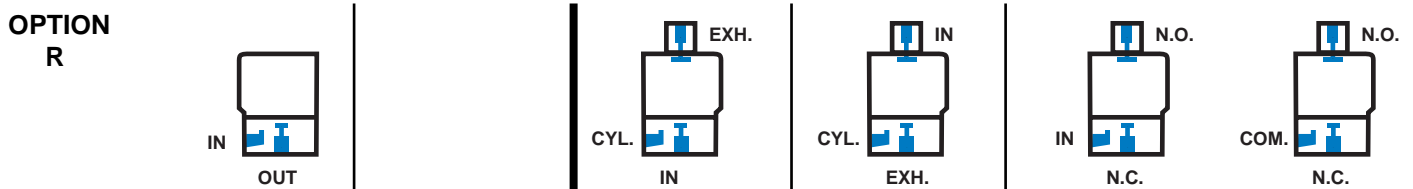

ORIFICE PORT AT BOTTOM

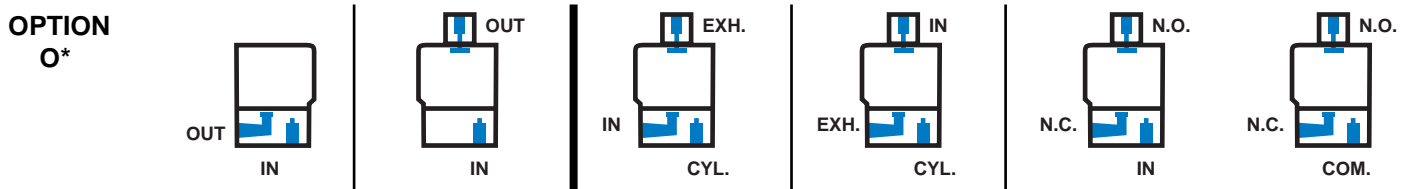

VALVE CAVITY PORT AT BOTTOM

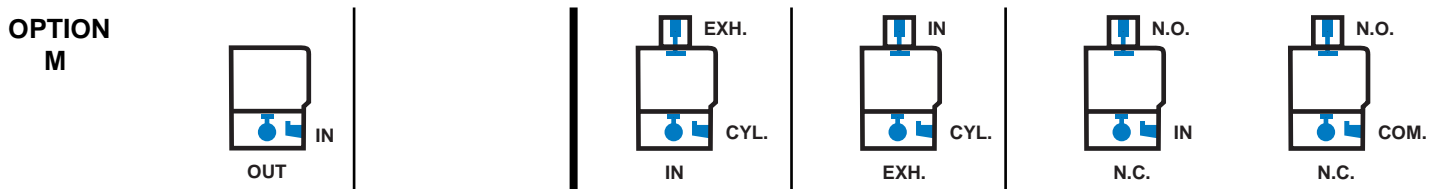

ORIFICE PORT 90° LEFT

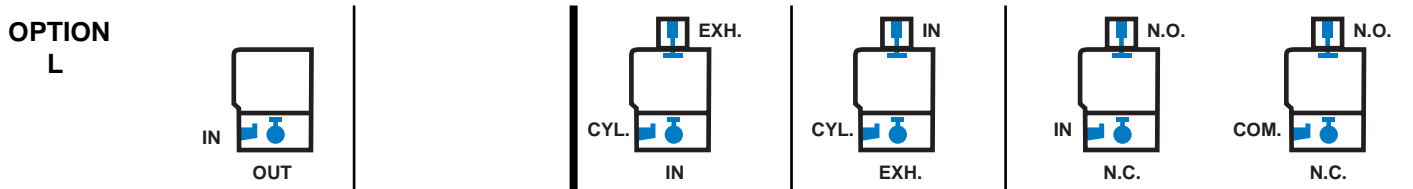

ORIFICE PORT 90° RIGHT

* BOTTOM OF PORT IS OFF CENTER

MAINTENANCE AND CLEANING INSTRUCTIONS SERIES 20, 30, & 50 VALVES

1. Shut off the pressure to the valve and electric current. The valve need not be removed from the line.
2. Remove nut at the top of the housing. Bottom flux plate (if present), housing and coil can then be removed from the body (the series 70 also has a Yoke inside the housing).
3. Using the special Peter Paul wrench (Part GP-010, GP-007 or GP-191) unscrew the sleeve assembly from the body. DO NOT use a pipe wrench, since a wrench may crush or mar the sleeve assembly and make the valve inoperative.

INSPECTION

1. If the valve fails to operate, the coil and control circuitry should be checked to make sure it is not burned out or open.
2. Occasionally, if mishandled, valves may leak at the flange seal. If the medium is a liquid, such a leak may damage the coil. A flange leak may be corrected by tightening the sleeve assembly into the valve body or replacing the gasket. Use wrench, Peter Paul Part GP-418 or GP-191.
3. If the valve leaks at the seat or the plunger sticks in the energized position, examine the soft inserts in the plunger and the inside of the sleeve assembly for the presence of excessive dirt or wear. If the inserts show considerable wear, the plunger should be replaced.

4. If the valve develops a loud buzzing noise, examine the inside of the sleeve assembly and upper portion of the plunger and remove all foreign matter imbedded in these parts. **Caution:** in Three-Way and Two-Way Normally Open Valves, be careful not to damage the sleeve seat. Do **not** clean plunger assembly or seals with any type cleaning fluid.

REASSEMBLY:

Reassemble the valve by following the disassembly procedure in reverse order. Make sure the seal of the flange end of the assembly and the return spring are in place when the sleeve is screwed into the body. After screwing the flange into the body and before assembling the coil to the valve, it is advisable to apply pressure to the port which leads to the body chamber and check for leakage around the flange. If the valve has a sleeve port, this port at the top of the valve must be capped to make this test. If the medium is air or gas, leakage can be noted by applying water to the joint and watching for air bubbles. If the medium is liquid, leakage is readily apparent. **DO NOT** tighten the nut at the top of the coil housing excessively, since doing so will put undue strain on the sleeve assembly.

REPLACEMENT PARTS:

Orders for replacement parts should include (1) Part Description, (2) Valve number, (3) Voltage.

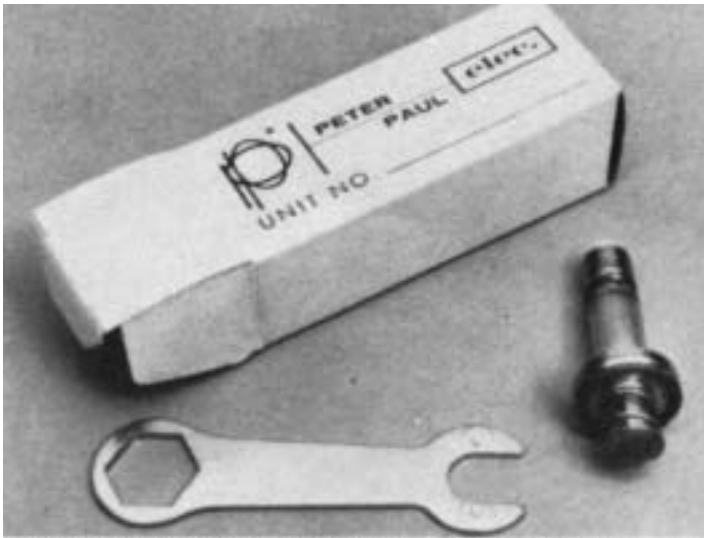

Install in 5 minutes

Directions:

With wrench supplied remove top nut and housing. Using the same wrench remove sleeve assembly plunger, spring, and seal. Discard all these underlined items do not re-use any portion of them.

Insert new components supplied. The re-assembled valve is ready for service. This simple operation brings the valve to the original performance level.

When ordering repair packs, add "AC" or "DC" to complete pack number (example) Pack No. K 21GDX AC

Repair pack consists of: Sleeve Assembly-Plunger-Spring-Seals-Wrench

Repair packs are listed along side of corresponding valve numbers beginning on page 6. Consult factory for repair packs not listed.

REPAIR PACKS

Another Peter-Paul innovation. The pack consists of critical components necessary to bring valves back into service, quickly and conveniently. The life of our quality valves can be extended economically and effectively in this manner.

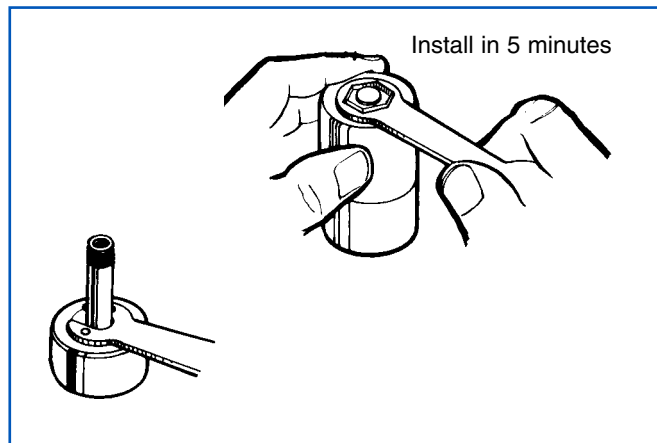

Definitions & Nomenclature Used In This Manual & Industry

Bubbletight Sealing — zero leakage between the internal sealed ports of a valve in either the energized or de-energized position. Test is based on the air and soap bubble type.

Current Drain — the amount of current expressed in amperes that flows through the coil of a solenoid valve when it is energized.

Compensated Plunger — a plunger designed to compensate for top insert problems that occur on application conditions of high heat when used with water, gasoline, etc. This condition causes standard inserts to swell or shrink, resulting in leakage. The compensated plunger design permits the top insert to move up or down to provide long life and a bubbletight seal at the top of the orifice. **Standard in all valves at no extra cost.**

Continuous Duty — a rating given to a valve that can be energized indefinitely without overheating or failure under normal operating conditions.

C_v factor — The C_v factor of a valve is the quantity of 60° F water expressed in gallons per minute, which will flow through a valve with a one PSI pressure drop. C_v factors for Peter Paul solenoid valves are indicated in the catalog listings in each section.

Cycle — a complete operation of a solenoid valve. For example: opening a normally closed valve and then closing it is one cycle.

Cycle Rate — the number of times a valve is capable of opening and closing its main orifice in a particular time interval.

Cycles per Minute (CPM) — the number of times a valve is capable of opening and closing its main orifice in one minute.

Dead End Gas Service — a condition in which two-way normally open or three-way valve applications require continuous energization or repetitive cycles for over 2 hours.

Drip Proof — see NEMA classifications

Drip Tight — see NEMA classifications

Dust Tight — see NEMA classifications

Duty Cycle — the longest time that a valve is energized, followed by the shortest time that it is de-energized.

Explosion-Proof Construction — a solenoid valve constructed to meet the specifications of the Underwriters' Laboratories, Inc. for operation in hazardous locations. See also NEMA classifications.

Flow — the continuous movement of fluid created by a pressure differential.

Flow Rate (Valve) — the amount of fluid through a valve in reference to pressure drop across the valve to carry magnetic flux from the housing to the sleeve assembly. A flux plate is required only on valves having a non-magnetic body material.

General Purpose Valves — valves suitable for application indoors under normal atmospheric conditions. See also NEMA and U.L. classifications.

Hazardous Locations — as defined by Underwriters' Laboratories, Inc. most Peter Paul explosion-proof valves are listed for use in the following hazardous locations: Class I, Group D, Class II, Group F and G. See also NEMA classifications.

Class I Locations — are those in which flammable gases or vapors are or may be present in the air in sufficient quantities to produce explosive or ignitable mixtures. Group D atmospheres are: gasoline, hexane, naphtha, benzene, butane, benzol, propane, alcohol, acetone, lacquer, solvent vapors, and natural gas.

Class II Locations — are hazardous because of the presence of mixtures of combustible dust. Group F atmospheres contain carbon black, coal or coke dust. Group G atmospheres contain flour, starch or grain dust.

Intermittent Duty Coil — a valve coil not designed for continuous duty but which will perform satisfactorily for a specified duty cycle.

Heat Rise — the difference between the temperature of the solenoid coil when energized and de-energized. As current flows through a coil, heat is generated. The coil temperature rises until the coil and valve construction dissipates additional heat as fast as it is generated, and the temperature stays at a stabilized level.

Insert — a material used in a plunger assembly to seal an orifice.

Definitions & Nomenclature (Continued)

Insert Material - Color coded for easy identification

Buna-N — a soft synthetic rubber used as the standard insert material in Peter Paul valves.

Kel-F — a synthetic plastic material used for many semi-corrosive media.

Neoprene — a soft synthetic rubber used as an insert material on certain types of Freons.

Nordel — a soft synthetic rubber used as an insert material on certain water and steam applications.

Nylon — a synthetic plastic material used for semi-corrosive media where Kel-F is not suitable.

Teflon — a synthetic plastic material used for semi-corrosive media where Kel-F or Nylon is not suitable.

Viton — a soft synthetic rubber used for high temperature and with many fluids not handled by Buna-N or Nordel.

Leakage, External — the leakage between the internal part of the valve and the external part of the valve. All Peter Paul valves have no external leakage.

Leakage, Internal — the leakage between the internal sealed ports of a valve in either the energized or de-energized position. All Peter Paul Standard Valves with standard (Buna-N) inserts are bubbletight when applied as rated.

Manual Override — a mechanical device that permits manual opening of normally closed valves or closing of normally open valves.

Metering — a mechanical device that permits manual adjustment of fluid flow through a valve. Sometimes referred to as speed control.

Oxygen Service — valves **specified** for use with oxygen are furnished free of any oil. Special cleaning may be required and should be so specified.

Port — an opening or passageway for the inlet or outlet of fluid in a valve. The terminus of the port is threaded with National Pipe Threads (NPT) to accommodate line connection. A port designated with an NPTF port indicates one with dry seal threads. A port designated with a PTF indicates one with short dry seal threads.

Port, Cylinder — a port which provides a passage to or from an actuator. This port is a common port and in multi-purpose valves is called a common port.

Port, Exhaust — a port which provides a passage to the atmosphere, or the return lines of a system.

Port, IN — a port which provides a passage from the source of fluid.

Port, OUT — the port where the fluid leaves the two-way valve.

Port, normally closed — the port that is closed to fluid flow when the valve is de-energized.

Port, normally opened — the port that is open to fluid flow when the valve is de-energized.

Power Consumption — the number of watts a solenoid valve draws when it is energized.

Pressure — is a potential force used as a propellant of air or fluid. Pressure is induced into a system by means of a pump, compressor, or by gravity. Absolute pressure is measured in pounds per square inch absolute (PSIA). Absolute pressure is the reference of pressure with 0 used as a base. Gauge pressure (or PSIG) is the reference of pressure with 14.7 pounds per square inch at sea level as a base.

Pressure, Burst — is the minimum pressure that would cause the weakest section of the valve to fail and cause external leakage.

Pressure, Differential (Drop) — is the difference in pressure measured between any two given points.

Pressure, Maximum Operating Pressure Differential — the maximum difference in pounds per square inch between the pressure at INlet port and the pressure at OUTlet port at which a solenoid will operate, either to open or to close one or more ports when energized or de-energized.

Pressure, Proof — is that pressure which may cause malfunction of the valve without permanent damage, i.e., the valve will operate properly when the pressure is reduced to normal operating range.

Pressure, Ratings:

Higher than Standard — are pressure ratings which can be made available through minor changes on a solenoid valve. In most cases, this is possible only when UL approval is not a factor.

Standard Catalog — are pressure ratings established to conform to Underwriters' Laboratories, Inc., and to do so under the most adverse conditions of pressure, low or high voltage, maximum heat rise, etc. The standard ratings listed in this catalog should be considered as conservative.

Response Time — the length of time required for the operating mechanism of a valve to move from the fully closed position to the fully open position, or vice versa. Response time will vary according to pressure, media, voltage and system. The response times shown in the catalog are based on average conditions.

U. L. and CSA Terms Nomenclature and Listings

Most standard Peter Paul series 20, 30, and E20 are U.L. and CSA listed. **All** Peter Paul Valves, including those not U.L. and CSA listed, use the high standards of U.L. as the minimum standard for performance. A copy of the U.L. and CSA cards regarding Peter Paul's valve listings is enclosed. The valves are listed under the following U.L. and CSA Guide Numbers and categories:

1. U.L. Guide No. 440 A5 (Valves Electrically Operated) Safety and General Purpose Valves.
2. U.L. Guide No. 440 A5-C (Component-Valves, Electrically Operated) Safety and General Purpose Valves.
3. U.L. Guide No. 440 AO (Valves, Electric, For Use in Hazardous Locations) Safety and General Purpose.
4. U.L. Guide No. 384 OO (Solenoids for Use in Hazardous Locations).
5. CSA Guide NO. 440-A-O, Class 3221 (Solenoid Valves)

Some terms and nomenclature as defined and used by Underwriters' Laboratories, Inc.:

General Purpose Valve — a valve intended to control the flow of a fluid, but not depended upon to act as a safety valve. It may be normally closed or a normally open valve.

Safety Valve — a normally closed valve of the "on" and "off" type intended to be actuated by a safety control or by an emergency device to prevent the unsafe delivery of a fluid. It may also be used as a "general purpose valve."

Hazardous Fluids — gases and liquids which are usually considered to be combustible, highly corrosive, or toxic such as acetylene, strong acids and alkalis, ammonia, anesthetics, liquefied petroleum, manufactured and natural gases, combustible oils, oxygen, etc.

Hazardous Locations — locations in which "hazardous fluids" may be present in the air in sufficient quantities to produce explosive or ignitable mixtures.

Peter Paul Explosionproof Valves and Solenoids are U.L. listed for use in the following hazardous location groups as defined by Underwriters' Laboratories:

Class I, Group A — Atmospheres containing acetylene.

Class I, Group B — Atmospheres containing acrolein, butadiene, ethylene oxide, hydrogen, propylene oxide.

Class I, Group C — Atmospheres containing ethyl-ether vapors, ethylene or cyclopropane.

Class I, Group D — atmosphere containing gasoline, hexan, naphtha, benzine, butane, propane, alcohol, acetone, benzol, lacquer, solve vent vapors, or natural gas.

Class II, Group E — atmospheres containing metal dust, including aluminum, magnesium, and their commercial alloys, and other metals of similarly hazardous characteristics.

Class II, Groups F and G — atmospheres containing carbon black, coal or coke dust, flour, starch or grain dust.

PETER PAUL ENCLOSURES FOR VARIOUS NEMA REQUIREMENTS:

NEMA (National Electrical Manufacturers Association) Standards for Electrical Enclosures are defined as listed below. The specific Peter Paul housing arrangements that meet these requirements are described below.

NEMA 1. GENERAL PURPOSE

To prevent accidental contact, protection from dust, but not dust tight. All Peter Paul standard housings, with **non-molded** or **molded** coils meet this requirement.

NEMA 2. DRIP TIGHT

To prevent accidental contact and to exclude falling moisture or dirt, Peter Paul **J.I.C. housing** with **non-molded** or **molded** coils are suitable.

NEMA 2. DRIP PROOF

To prevent accidental contact and protection against falling moisture or spray from interfering with operation. All Peter Paul standard housings with **molded** coil or Peter Paul **J.I.C. housing** with **non-molded** or **molded** coils meet this requirement.

NEMA 3. WEATHER RESISTANT

To provide suitable protection against falling moisture or spray from interfering with operation. All Peter Paul standard housings with **molded** coil or Peter Paul **J.I.C. housing** with **non-molded** or **molded** coils meet this requirement.

NEMA 4. WATER TIGHT

To provide entrance of water after a specific hose test. Peter Paul **J.I.C. housing with non-molded coil**, **molded**, or potted coil meets this requirement.

NEMA 5. DUST TIGHT

To prevent entrance of dust by use of gaskets or equivalent. Peter Paul **J.I.C. housing** meets this requirement with **non-molded** or **molded** coil, or potted coil.

U. L. and CSA Terms Nomenclature and Listings (Continued)

NEMA 6. SUBMERSIBLE

Constructed so that it will operate successfully when submerged in water under specific conditions of pressure and time. Liquid potted coils meet this requirement.

NEMA 7. — AND UNDERWRITERS' LAB. CLASS I — GROUP D — EXPLOSION PROOF

Where flammable gases are present, specifically, gasoline, hexane, naphtha, benzine, butane, propane, alcohol, acetone, benzol, lacquer solvent vapors and natural gas. **Non-molded** or **molded** coils in Peter Paul explosion proof valves meet this requirement.

NEMA 8.

As above (NEMA 7) except unit is oil immersed. Peter Paul **explosion proof valves with molded coils** meet this requirement. (Class I - Group D and Class II - Group F and G.)

NEMA 9 AND 9A AND UNDERWRITERS' LAB CLASS II— GROUP F AND G

Where combustible dust is present. Specifically, Group F (carbon black, coal or coke dust) and Group G (flour, starch and grain dust). **Non-molded** or **molded** coils in Peter Paul explosion proof valves meet this requirement.

COIL TEMPERATURE CLASS CHART

Class A	105 C / 221 F
Class B	130 C / 226 F
Class F	155 C / 311 F
Class H	180 C / 356 F
Class N	200 C / 392 F
Class C	220 C / 428 F

Valve Types and Function

The basic Peter Paul Valves are electromagnetically actuated, direct operating, solenoid-type valves with resilient inserts that seal upon the orifice.

De-energized - When a valve is de-energized it is said to be in its “normal condition” and no current flows through the electrical coil winding.

Energized - When current is permitted to flow through the coil and the resultant magnetic flux overcomes the fluid pressure and spring force and brings the plunger up against the stop.

Normally Closed Valve - a valve in which the inlet orifice is closed when the coil is de-energized and open when the coil is energized.

Normally Open Valve - a valve in which the inlet orifice is open when the coil is de-energized and closed when the coil is energized.

Multi-Purposed Valve - a valve which has combinations of normally closed, normally open or normally closed and normally open orifices in one valve unit which are opened or closed by energizing or de-energizing the coil.

Directional Control Valve - a valve in which the inlet is open to the normally closed port when the coil is energized.

Two-Way Valve - a valve that has a single orifice which may be normally open or normally closed.

Refer to the cross-sectional drawings on the following pages for the desired valve description.

Two-Way Normally Closed (2 W.N.C) - a valve in which the orifice is closed in the de-energized position and no flow can exist between the inlet and outlet ports.

Two-Way Normally Open - (2 W.N.O.) - a valve in which the orifice is closed in the de-energized position and no flow can exist between the inlet and outlet ports.

Two-Way Dual Purpose Valve - (2 W.D.P.) - a valve that will function properly with rated pressure at either the IN port or OUT port in the energized or de-energized position.

Three-Way Valve - a valve that has two orifices and three ports. One orifice is always open when the other is closed and one port is always open to one of the other two ports. Flow is controlled by opening or closing either of the two orifices.

Three-Way Normally Closed - (3 W.N.C.) - a valve in which inlet orifice is closed and the exhaust orifice is open in the de-energized position. No flow can exist between the inlet cylinder ports. Full flow can exist between the cylinder and exhaust ports.

Three-Way Normally Open (3 W.N.O.) - a valve in which the inlet orifice is open and the exhaust orifice is closed in the de-energized position. Full flow can exist between the cylinder and exhaust ports.

Three-Way Directional Control (3 W.D.C.) - a valve in which the inlet is open to the normally open port when the coil is de-energized and open to the normally closed port when the coil is energized.

Three-Way Multi-purpose (3 W.M.P.) - a valve in which will function as three-way normally open, as three-way normally closed, and three-way directional control, depending on piping hookup.

Direct Action Valve - a valve in which flow is controlled directly by the plunger and the spring in the magnetic circuit and is not dependent on any other factors. There are only two moving parts.

Internal Pilot-Operated Valve - a valve that operates on a minimum and maximum pressure differential and uses a small orifice size “direct acting” valve to open and close a much larger main orifice size valve. The main orifice is operated and closed by pressure differential across a diaphragm, spool or piston built into the main valve body.

External Pilot-Operated Valve - a valve that operates in a similar manner to the internal type except that the pilot valve operated from a separate source of pressure.

Servo-Valve - a valve sometimes referred to as a “proportioning valve.” The extent of orifice opening or flow is controlled by extent or amount or electrical signal inputs.

Synthetic Insert Material for Valves

Color Coded for easy Identification

The information is a general guide and can be changed due to media and type of valve being considered.

Type	General Purpose Buna N		FKM		Neoprene®		EPDM	
Code #	Code.	Duro.	Code.	Duro.	Code.	Duro.	Code.	Duro.
Durometer	A	(80-90)	V	(70-80)	G	(75-85)	U	(80-90)
	B	(70-80)	I	(80-90)	R	(70-80)	X	(70-80)
	C	(55-65)	N	(90-95)	L	(80-90)		
	D	(70-80)						
	H	(70-80)						
	P	(90-100)						
Property	Acrylonitrile Rubber		Fluoroelastomer		G. N.		Ethylene-Propylene Elastomer	
Oil Resistance	Excellent up to 225 F.		Excellent up to 400 F.		Good up to 225 F.		Fails	
Water Resistance	Excellent up to 150 F.		Good up to 180 F.		Good up to 150 F.		Excellent 210 F.	
Air Resistance	Excellent up to 180 F.		Excellent up to 350 F.		Excellent up to 180 F.		Good (no oi) up to 180 F.	
Abrasion Resistance	Excellent		Excellent		Excellent		Good	
Age Resistance	Excellent		Good		Excellent		Excellent	
Steam Resistance	Fail		Fail		Fail		Good (to 300 F.)	
Low Temp Range	-40 to -65 F.		+10 to -10 F.		-40 to -65 F.		-40 to -60 F.	
High Temp. Cont. Duty	+230 to +240 F.		+325 to + 350 F.		+230 to +240 F.		+250 to +300 F.	
High Temp. Int. Duty	+25 to +300 F.		+425 to +450 F.		+260 to +280 F.		+350 to +400 F.	

COMPENSATED PLUNGERS

Peter Paul supplies compensated plunger in all cases at no extra charge.

WHAT IS A "COMPENSATED PLUNGER"

The "Compensated Plunger" permits the top insert to move up and down thus providing long life and bubble-tight sealing at the top orifice. The design provides a metal-jacketed top insert that is spring loaded. This plunger is offered with various insert materials to suit different applications. It is offered with Standard Buna-N (no charge). FKM, EPDM, Neoprene, Teflon, Kel-F or Nylon insert material are available.

WHY A COMPENSATED PLUNGER IS USED

A general property of rubber products is to dry, shrink and harden with the application of heat. Another property is the change in volume and swelling that takes place in liquids. Various liquids and chemical formulations will affect different insert materials to varying degrees.

The specific advantages of a compensated plunger are when:

1. A liquid media is being used in a Three Way Valve or a Two Way Normally Open Valve.
2. A Three Way Valve or a Two Way Normally Open Valve is continuously energized for two hours or longer.
3. A Three Way Valve or a Two Way Normally Open Valve is operating at a high cycle rate (greater than 200 C.P.M.)
4. A Three Way Valve or a Two Way Normally Open Valve is operating at a long duty cycle (such as "On Time"=1 hour, "Off Time" = 10 minutes)
5. A Three Way Valve or a Two Way Normally Open Valve is "dead ending" (no flow when energized) for repetitive cycles that have an "On Time" greater than 1 1/2 hours.
6. A Three Way Valve or a Two Way Normally Open Valve is being used with media of excessive temperature.
7. A combination of the above-consult factory on any questionable applications.

TYPE OF INSERT MATERIAL TO APPLY

Refer to the above table describing each insert material. Consult factory for any questionable applications and for other Seal Material options.

Metering Options

When a critical or controlled amount of flow is required, a metering device is incorporated in the valve body. This allows adjustment of flow through the valve from nearly zero to fully open for pressures up to 300 PSI. If a metering device is required for higher pressures, consult the factory.

Two basic metering devices are offered. These are the “stem” (option “F”) and the “screw” (options “T” standard) and “A” (fine). Other metering functions offered are “metered by-pass” (option “W”) and “metered sleeve, to atmosphere” (option “U”).

Standard Screw Type Metering (T)

This is a precision tapered screw and is used to adjust the flow of orifice sizes 3/64 to 1/8 inch. It can meter flow down to a degree of extremely low leakage. If bubble-tight leakage is required, consult the factory. This type of metering can be fabricated to meter the flow through the valve body cavity port or the valve body orifice port. Thus, if two 3 Way Valves are used to operate a double acting cylinder, the forward stroke, return stroke, or both strokes of the cylinder may be adjusted to obtain a given required operating speed by desired valve and metering selection. The “Standard” Screw-Type Metering travels from closed to full orifice opening in approximately 2 1/2 turns. Stock valves are fabricated to adjust orifice port flow.

Fine Screw Type Metering (A)

This is a precision tapered screw to give fine adjustment of orifice sizes sizes 3/64 to 1/8 inch. The fine metering screw is 4 xs finer in adjustment than the standard. Thus if the standard metering takes 1/4 of a turn from closed position to obtain desired metering, the fine would take one full turn to adjust to the same point. The full adjustment range of the fine metering is approximately 2 1/2 turns (same as standard). It can adjust flow down to extremely low leakage (bubbles). If bubble-tight leakage is required, consult the factory.

Stem Type Metering (F)

This metering device is for orifice sizes 5/32 to 1/4 inch. Seven full turns are required to fully open a 1/4 inch valve body orifice. This metering device can not be adjusted to bubble-tight leakage and is only offered as an orifice port metering device.

Metered By-Pass (W)

This type of metering device is offered when an adjustable flow is required to pass through the valve regardless of whether the valve is energized or de-energized and whether the orifice being opened or closed. Thus a by-pass with a metering device is fabricated into the valve body. Consult the factory with specific requirements.

Adjustable Sleeve Exhaust (U)

This is a metering device that is placed in the top of the sleeve assembly and exhausts to atmosphere. This is particularly useful in adjusting an air operated cylinder’s return stroke speed.

All metering options are described and listed in that section of the catalog. Metering location is considered standard as listed. Check customer’s location requirement. Apply standard location, if at all possible. The metering can be offered with directly opposite location. If the quantity is large enough there will be no extra charge. If other locations are required consult the factory.

Manual Override (Y)

This is mechanical device that permits a person to operate the valve by either hand or screwdriver. This is useful in case of a power failure or to assist in machine or system set-up or test.

The manual override location is listed in that section of the catalog. These locations are standard and are a stock item. The manual override can be offered with directly opposite location.

GANG FEEDING OPTION

In application where numerous solenoid valves are connected to the same supply line, considerable savings can be achieved by eliminating fittings. This can be done by using a multi-ported valve body where one of the pipe ports is a feed-through supply.

Using this method, the feed-through ports can be connected in a line resulting in a simplified piping. Only one valve requires connection with the main supply line. This feature can be offered in a 2 Way or 3 Way valves.

Application

Vending Machines: Where different valves are connected to the same water line, but the outlet feeds different circuits.

Packaging Machines: Where the air supply is required to actuate different cylinders at different times, but feed from the same source.

Automation: So that more valves can fit in a limited space.

GANG FEEDING (continued)

Specification:

Gang feeding can be applied in both 1/8 or 1/4 NPT pipe ports.

Applicable on series 20 and 30 valve lines.

Gang feeding can be applied on 2 Way or 3 Way valves.

Connecting Pipe: Standard straight pipe 1/8 or 1/4 NPT with a minimum length of 1.0 inch.

2 Way Normally Closed: Two inlet ports and one outlet port. Valve can be fed from either of the inlet ports, while the other inlet port is connected with the inlet port of the next valve in the line.

3 Way Normally Closed: Two inlet ports and one cylinder and exhaust port. One inlet port is connected with the next valve's inlet port. If the two valves are "ganged" it is equivalent to a 4 Way Valve.

Directional Control: Two inlet ports and one N.C. and one N.O. port. One of the inlet ports is connected to the next valve in line and a multi-directional valve is obtained. (More than 2 directions, depending on the number of valves.

Orifice Size: Any valve body with standard orifice can be supplied.

VALVES FOR MANIFOLD MOUNTING

Peter Paul Electronics Co. produced two types of Solenoid Valves which can be mounted on a manifold.

Bottom Mounted Manifold Feed: (Print No. 20-3025)

Suitable for applications where the valve's body can be mounted by using two 10-32 holding screws at the bottom of the valve body. The advantage of this method is the economical utilization of space, lower cost and immediate availability.

Flange Mounted Manifold Feed: (Print No 20-3012)

Suitable for application where the valve's body has to be mounted from the upper end (Face) of the manifold. Since mounting is accomplished by a flange, the space requirement is greater than the bottom mounted manifold feed. Customer must use the two locating holes to avoid mis-application.

Sleeve Port: Since the sleeve port is not part of the valve body, its connection to the manifold, if necessary, has to be made by using copper tubing or by using flexible hoses.

COIL TYPES

Peter Paul manufactures all coil in our own plant to rigid manufacturing and quality standards. This makes for excellent availability and delivery of all types for all voltages.

The only coils presently U.L. listed are types V and M.

Non-Molded (Type V)—Class A rated at 105° C.—IEEE* and 110° C. Continuous & 125° C. Intermittent—U.L.

Molded (Type M)—Class F rated at 155° C.—IEEE* and 110° C. Continuous & 125° C. Intermittent— U.L.** The coils are moisture proof.

High Temperature Molded (Type H)—Class H rated at 180° C.—IEEE* and 160° C. Continuous & 175° C. Intermittent—(Non-Published) U.L.** The coils are moisture resistant.

POTTED (Type P)—Class F rated at 105°—IEEE* and 110° C. Continuous & 125° C. Intermittent—U.L.** Peter Paul Rating*** 125° Continuous. The unit is water proof.

IEEE—The temperatures listed are the limiting temperature definitions by this organization for insulation material categories.

****U.L.**—The temperatures listed are the maximum permissible temperatures for the total of coil resistance temp, rise and ambient temp for the complete coil.

COIL SELECTION FOR SERIES 20, 30, 40, 50 & 70 VALVES

In selecting coils for various “odd voltage” requirements, the following formula should be observed.

If an applied voltage (A.C.) falls between the rated voltage of two coils (rated voltage appears on Coil Charts), take 40% of the difference in voltage between the two coils and add to the lower voltage rating. If the resulting figure is equal to or larger than the applied voltage, the coil with the lower voltage rating should be used. If the resulting figure is smaller than the applied voltage, the coil with the higher voltage rating should be used.

Example: Field Voltage 130v/60cy.
 The 2C-115 Coil has a rated voltage of 138v/60y.
 The 2C-114 Coil has a rated voltage of 120v/60y.
 18v (difference)

40% of 18 Volts7v
 120v (lower volt. rating)
 127 v is the max. 60 cy.
 Voltage for 20C-114

Therefore, a 2C-115 coil should be used with a field Voltage of 130 volts 60 cycles.

Coils selected under the above formula will operate successfully at 10% below and 10% above the nominal applied voltage.

This general rule for coil selection should only be used with “Standard Valves” in the Series 20, 30, 40, 50, & 70 operated under “Standard Conditions”. For clarity, definition of what is meant by “Standard Valves” and “Standard Conditions” follows.

Non-Molded



Molded



Potted



Technical Information

General

The following table will assist in determining the suitability of Peter Paul valves for a wide range of common media.

Media Variables

Quite often the exact chemical composition, concentration or application conditions can vary the corrosive effect of some media. In these cases Peter Paul must be consulted and the code note (PP) appears. When requesting recommendations in these cases the following information must be provided.

1. Exact composition of media.
2. Concentration of media.
3. Temperature range.
4. Pressure range.
5. Length of exposure.
6. Allowable Leakage.
7. Valve life expectancy.

Uncommon Media

Often requests are received to recommend valves for media with which we've had no prior experience and which do not appear in tables furnished by the Steel, Rubber and Plastic manufacturers.

In such cases the prospective customer is often in the best position to know what materials are compatible. Thus, there is a table that follows listing Peter Paul Valve materials.

Note

- (1.) The following recommendations are limited to Media whose temperature range between 0 F. and 180 F. Consult Peter Paul when either lower or higher temperatures are expected.
- (2.) Three-Way normally closed valves that exhaust to atmosphere are usually restricted to air service.

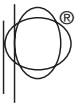

Media Table for Peter Paul Valve Series

Media	2 W.N.C Series 20, 30 50, 70 & E20 S.S. Body	2 W.N.C. Series 20 & 30 Brass Body	2 W.N.O. & All 3 W. Series 20, 50, 70 & E20 S. S. Body	2 W.N.O. & All 3 W. Series 20 Brass Body
Acetic Acid	NR	NR	NR	NR
Acetone	PP	PP	PP	PP
Air (up to +180 F. to +300 F.)	V	V	V	V
Alcohol (Methyl)	PP	PP	PP	PP
Alcohol (General)	R	R	R	R
Alkali	PP	NR	PP	NR
Ammonia	PP	NR	PP	NR
Argon	R	R	R	R
Aromatic Amines	PP	NR	PP	NR
Benzene	V**	NR	V**	NR
Butane	R	R	R	R
Carbon Dioxide (Dry Gas)	R	R	R	R
Carbon Tetrachloride	V**	NR	V**	NR
Chlorinated Hydro-Carbon	PP	PP	PP	PP
Chlorine (Dry)	*PP	NR	PP	NR
Chlorine (Wet)	NR	NR	NR	NR
Citric Acid	NR	NR	NR	NR
Diesel Fuel	R	R	R	R
Ethers	R	R	R	R
Ethyl Acetate	PP	NR	PP	NR
Ethylene (Glycol)	R	R	R	R
Formaldehyde	K*	NR	K*	NR
Freon - 11	K	NR	K	NR
Freon - 12	R	R	R	R
Freon - 22	N	N	N	N
Freon - (Other)	PP	PP	PP	PP
Fuel Oil	R	R	R	R
Gasoline (High Test)	V**	V**	V**	V**
Gasoline (Low Test)	R	R	R	R

CODE

- R = Recommended
- NR = Not Recommended
- PP = Consult Peter Paul
- V = FKM Plunger Inserts
- N = Neoprene® Plunger Inserts
- T = Teflon® Plunger Inserts
- NE = Nordel Plunger Inserts

Air & Inert Gases—if application involves continuous energization of valves Type “V” inserts should be used to prolong valve life on 3 Way applications. Do this also if “dead ending” (no flow when energized).

- * Teflon® Flange Seal
- ** With FKM Flange Seal
- *** Aluminum Shading Ring



Media Table for Peter Paul Valve Series

Media	2 W.N.C. Series 20, 30 30, 50, 70 & E20 S.S. Body	2 W.N.C. Series 20 & 30 Brass Body	2 W.N.O. & All 3 W. Series 20, 50, 70 & E20 S. S. Body	2 W.N.O. & All 3 W. Series 20 Brass Body
Hydraulic Oil				
Non-Flammable	NR	NR	NR	NR
Standard	R	R	R	R
Hydrochloric Acid	NR	NR	NR	NR
Hydrogen	R	R	R	R
# Inert Gases	R	R	R	R
JP4 - JET Fuel	V	V	V	V
JP5 - JET Fuel	V	V	V	V
Kerosene	R	R	R	R
Ketones	PP	NR	PP	NR
Lacquer	PP	PP	PP	PP
Linseed Oil	R	R	R	R
Lubrication	R	R	R	R
Mercury	R***	NR	R***	NR
Natural Gas	R	R	R	R
Nitric Acid	PP	NR	PP	NR
Nitrogen	R	R	R	R
Oxalic Acid	NR	NR	NR	NR
Oxygen	R	R	R	R
Phosphoric Acid	NR	NR	NR	NR
Propane	R	R	R	R
Salt Water	R	RR	R	PP
Sodium Hydroxide	NR	NR	NR	NR
Solvents	PP	PP	PP	PP
Steam	PP	NR	PP	NR
Toluene	PP	PP	PP	PP
Water				
Under +175 F.	R	R	NI	NI
Over +175 F.	NI	NI	NI	NI

CODE

- R = Recommended
- NR = Not Recommended
- PP = Consult Peter Paul
- V = FKM Plunger Inserts
- K = KeL-F® Plunger Inserts
- N = Neoprene® Plunger Inserts
- T = Teflon® Plunger Inserts
- NE = Nordel Plunger Inserts

Air & Inert Gases—if application involves continuous energization of valves Type “V” inserts should be used to prolong valve life on 3 Way applications. Do this also if “dead ending” (no flow when energized).

- * Teflon® Flange Seal
- ** With FKM Flange Seal
- *** Aluminum Shading Ring

SERIES 20 & 30 AIR FLOW CHARTS

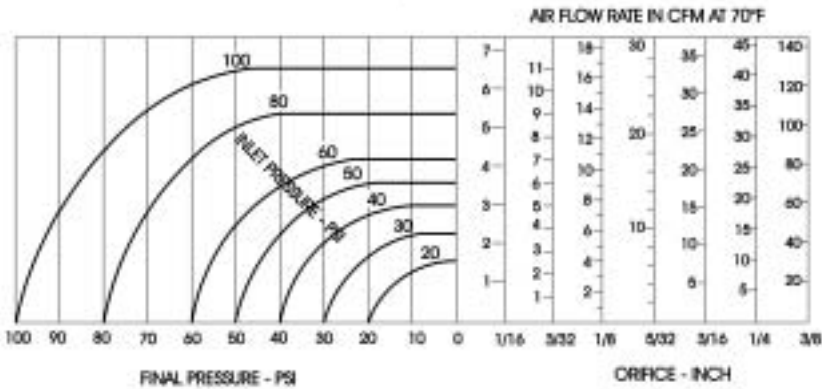

AIR FLOW EXAMPLE

This chart directly correlates the anticipated air flow rate to initial pressure, final pressure and pressure drop for a given orifice.

EXAMPLE: Find the two-way normally closed valve than can deliver 5 CFM of air at 70°F and 200 PSIG inlet pressure if the pressure drop across the valve is 25 PSI. On the valve pressure rating chart you find that a 1/16 orifice is recommended for 200 PSI pressure drop. Draw a vertical line (dotted line) from 175 PSI "final

pressure" line up to the curve of initial pressure 200 PSI. Draw a horizontal line from this point to the 1/16" orifice scale. Read the flow rate - 7.3 CFM.

The chart also can be used to establish required pressure drop if orifice size and required flow is known. Merely reverse the above procedure. When low pressure is involved, it is easier to obtain accurate flow rate using the enlarged flow chart.

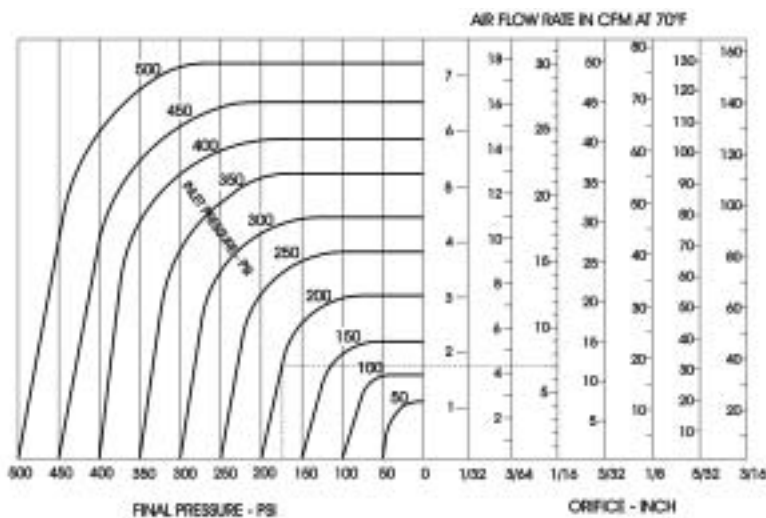

SERIES 20 & 30 WATER FLOW CHARTS

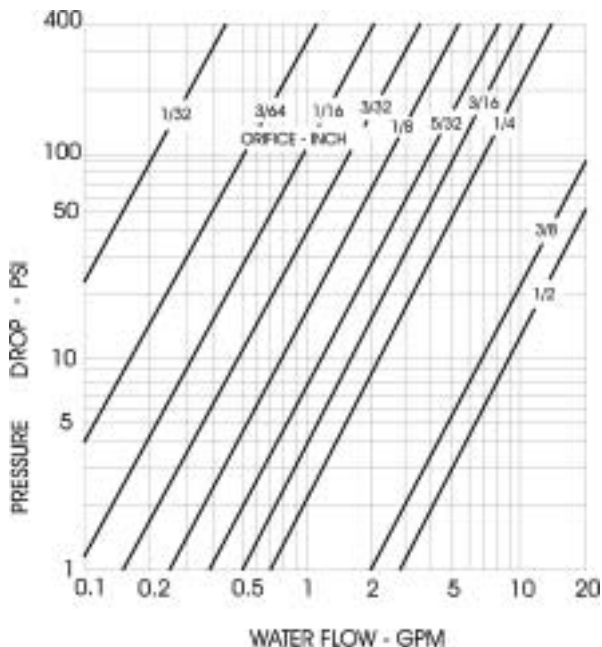

WATER FLOW EXAMPLE

This chart directly gives the anticipated water flow if the orifice size and pressure drop are known.

EXAMPLE: Establish the flow through a 1/8" orifice, two-way, normally closed valve if the inlet pressure is 80 PSIG, and the outlet pressure in 70 PSIG.

The pressure drop across the valve is 80-70 or 10 PSIG. At the intersection of the 10 PSIG and the 1/8" orifice lines (dotted lines) drop down to the flow scale and read 0.8 GPM.



SOLENOID VALVES . . .

SERIES 15 FLOW CHARTS

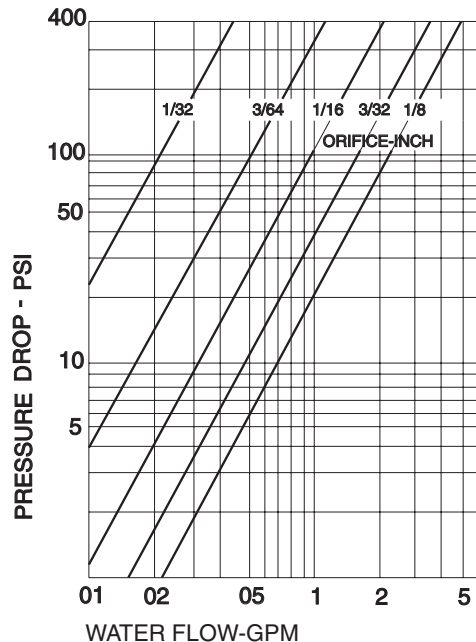
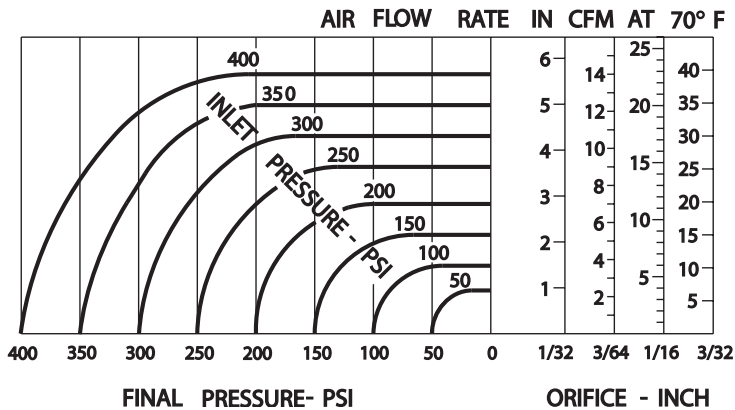

SERIES 50 FLOW CHARTS

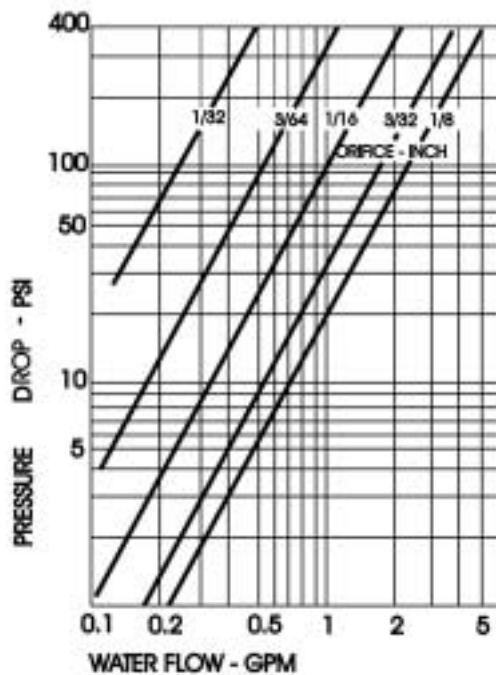
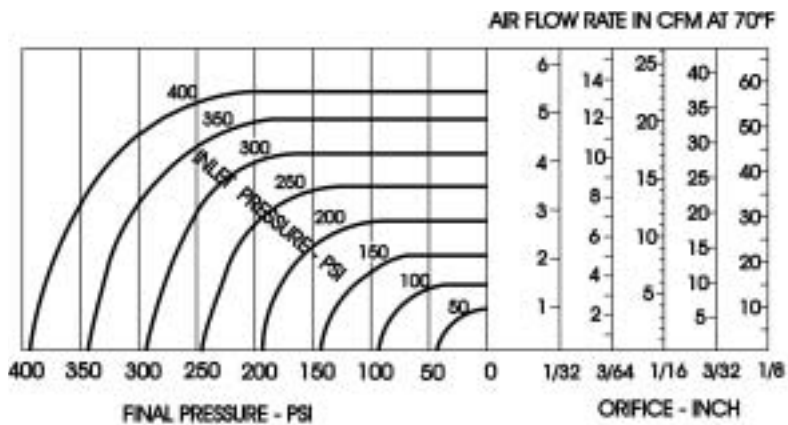

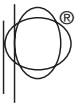

SERIES 70 FLOW CHARTS

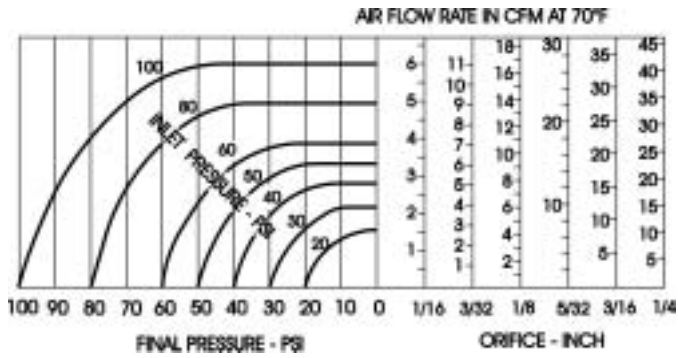
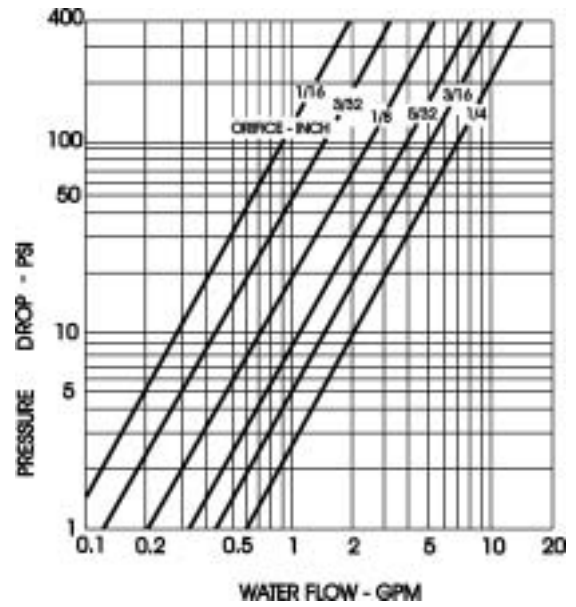
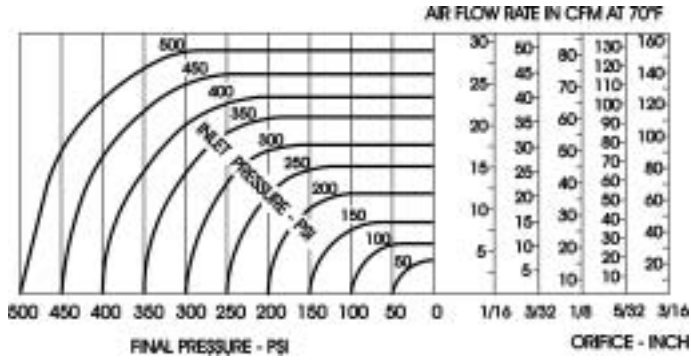

SERIES 40 FLOW CHARTS

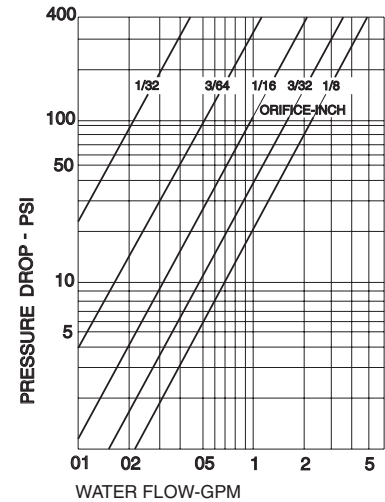
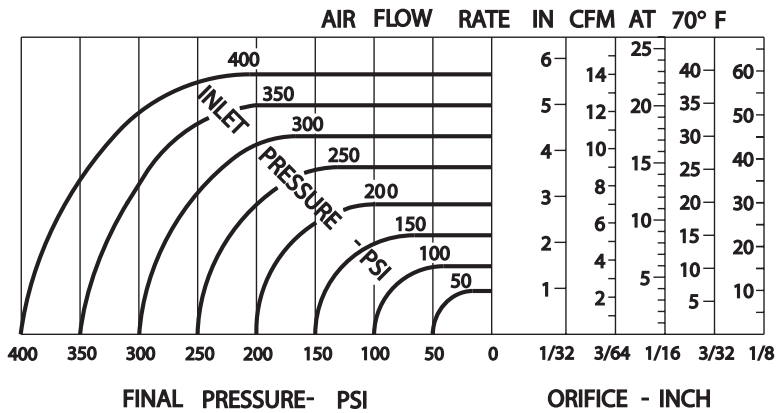

SERIES 58 FLOW CHARTS

AIR FLOW RATE IN CFM AT 70° F

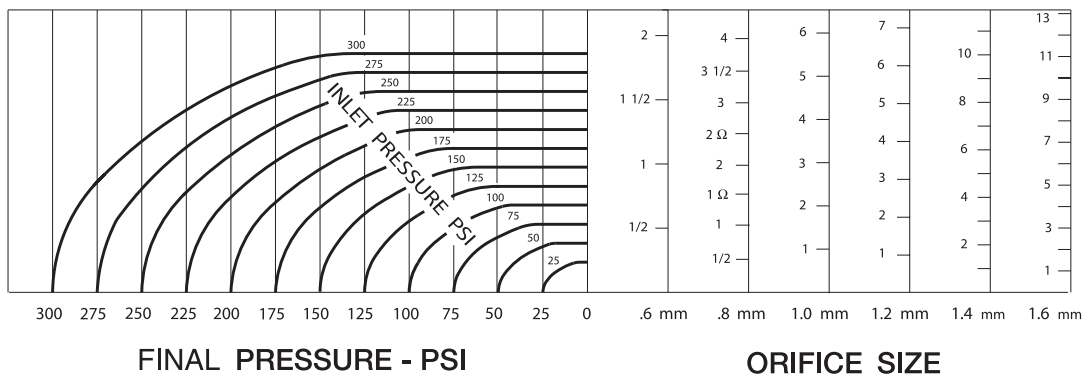

COILS VOLTAGES & FREQUENCIES

The coil chart shows applicable voltages for various frequencies. Specify voltages and frequencies as listed below when ordering. Consult factory for voltages and frequencies not listed.

SERIES 15 COIL AND VOLTAGE CHART

A.C. VOLTAGES		D.C. VOLTAGES	CONDUIT ASSEMBLY COIL NO.	LEADWIRE ASSEMBLY COIL NO.	DIN* CONNECTOR ASSEMBLY COIL NO.
60 HZ.	50 HZ.				
8.4	7.7	5.0	15-17040-3	15-17039-3	*15-17034-3
4.8	4.4	3.0	15-17040-4	15-17039-4	*15-17034-4
9.7	8.9	6.0	15-17040-5	15-17039-5	*15-17034-5
12.0	11.0	8.0	15-17040-6	15-17039-6	*15-17034-6
19.5	18.0	12.0	15-17040-9	15-17039-9	*15-17034-9
24.0	22.0	16.5	15-17040-10	15-17039-10	*15-17034-10
38.0	35.0	24.0	15-17040-13	15-17039-13	*15-17034-13
43.0	40.0	28.0	15-17040-14	15-17039-14	*15-17034-14
76.0	70.0	48.0	15-17040-15	15-17039-15	*15-17034-15
120	110	82.0	15-17040-16	15-17039-16	*15-17034-16
61.0	56.0	38.0	15-17040-17	15-17039-17	*15-17034-17
100	91.0	68.0	15-17040-18	15-17039-18	*15-17034-18
240	220	165	15-17040-19	15-17039-19	*15-17034-19
277	255	180	15-17040-20	15-17039-20	*15-17034-20
141	127	102	15-17040-E17	15-17039-E17	*15-17034-E17
260	240	175	15-17040-E21	15-17039-E21	*15-17034-E21
26	24	17.0	15-17040-E10	15-17039-E10	*15-17034-E10
131	120	86.0	15-17040-E16	15-17039-E16	*15-17034-E16
48.0	45.0	30.0	15-17040-12	15-17039-12	*15-17034-12
208	187	140	15-17040-21	15-17039-21	*15-17034-21
58	53	36.0	15-17040-24	15-17039-24	*15-17034-24
214	194	125	15-17040-25	15-17039-25	*15-17034-25
155	140	107	15-17040-E18	15-17039-E18	*15-17034-E18

* Din Connector No. 50-17029 not included with coil

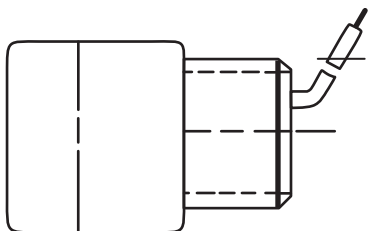

CONDUIT STYLE

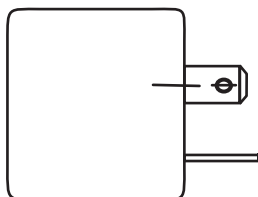

EUROPEAN STYLE

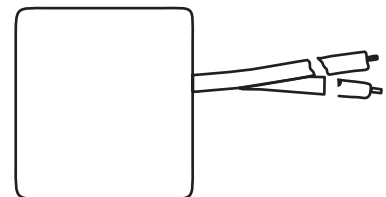

LEADED STYLE

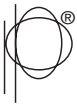

SOLENOID VALVES . . .

The coil chart shows applicable voltages for various frequencies. Specify voltages and frequencies as listed below when ordering. Consult factory for voltages and frequencies not listed.

SERIES 20, 80 COIL CHART

A.C. VOLTAGES		D.C. VOLTAGES	NON-MOLDED COIL NO.	MOLDED COIL NO.
60 HZ.	50 HZ.			
6	5	1.8	2C-102-A24	2C-2-K24
7	6	2.2	2C-103-A24	2C-3-K24
12	10	3.7	2C-104-A24	2C-4-K24
14	12	4.4	2C-105-A24	2C-5-K24
19	17	6	2C-106-A24	2C-6-K24
24	21	7.5	2C-107-A24	2C-7-K24
28	24	9	2C-108-A24	2C-8-K24
30	26	9.5	2C-109-A24	2C-9-K24
38	33	12	2C-110-A24	2C-10-K24
48	42	15	2C-111-A24	2C-11-K24
55	48	18	2C-112-A24	2C-12-K24
77	67	24	2C-113-A24	2C-13-K24
120	100	38	2C-114-A24	2C-14-K24
138	120	45	2C-115-A24	2C-15-K24
157	135	48	2C-116-A24	2C-16-K24
240	208	75	2C-117-A24	2C-17-K24
360	314	115	2C-118-A24	2C-18-K24
380	330	120	2C-119-A24	2C-19-K24
480	415	150	2C-120-A24	2C-20-K24
575	500	187	2C-121-A24	2C-21-K24
730	635	240	2C-122-A24	2C-22-K24
825	720	265	2C-123-A24	
400	345	125	2C-125-A24	2C-25-K24
204	175	60	2C-126-A24	2C-26-K24
265	230	80	2C-127-A24	2C-27-K24
110	95	35	2C-130-A24	2C-30-K24
650	560	220	2C-131-A24	2C-31-K24
175	155	55	2C-132-A24	2C-32-K24
85	75	28	2C-133-A24	2C-33-K24
145	127	45	2C-134-A24	2C-34-K24
600	517	188		2C-35-K24
16	14	4.8	2C-136-A24	
320	275	100		2C-37-K24
120/240	(dual voltage coils)		2C-138-A24	(Non-molded only)
240/480	(dual voltage coils)		2C-139-A24	(Non-molded only)
120	110	42	2C-140-A24	2C-40-K24
24	24	7	2C-141-A24	2C-41-K24
240	220	77	2C-143-A24	2C-43-K24
220	188	65	2C-144-A24	2C-44-K24
230	200	67	2C-145-A24	2C-45-K24
67	60	20	2C-146-A24	2C-46-K24

EXPORT COILS

126	110	42	2CE-114-A24	2CE-14-K24
135	115	44	2CE-115-A24	2CE-15-K24
255	220	78	2CE-116-A24	2CE-16-K24
275	240	90	2CE-117-A24	2CE-17-K24
435	380	145	2CE-119-A24	2CE-19-K24
500	440	172	2CE-120-A24	2CE-20-K24
100	85	32	2CE-140-A24	2CE-29-K24

DIODE RECTIFIED COILS

240			2CD-117-A24	
120			2CD-128-A24	
24			2CD-131-A24	
115/400			2CD-132-A24	
120	110		20-17067	
		24	20-17073	

The coil chart shows applicable voltages for various frequencies. Specify voltages and frequencies as listed below when ordering. Consult factory for voltages and frequencies not listed.

SERIES 30 COIL CHART

A.C. VOLTAGES		D.C. VOLTAGES	NON-MOLDED COIL NO.	MOLDED COIL NO.
60 HZ.	50 HZ.			
6	5.2	2	3C-101-A24	3C-1-K24
7.8	6.7	2.5	3C-102-A24	3C-2-K24
9	7.7	3	3C-103-A24	3C-3-K24
			3C-104-A24	3C-4-K24
			3C-105-A24	3C-5-K24
12	10	4	3C-106-A24	3C-6-K24
16	14	5	3C-107-A24	3C-7-K24
18	15	6	3C-108-A24	3C-8-K24
24	20	7.8	3C-109-A24	3C-9-K24
27	23	9	3C-110-A24	3C-10-K24
37	32	12	3C-111-A24	3C-11-K24
48	40	15	3C-112-A24	3C-12-K24
100	85	33	3C-113-A24	3C-13-K24
73	60	24	3C-114-A24	3C-14-K24
82	70	28	3C-115-A24	3C-15-K24
120	100	40	3C-116-A24	3C-16-K24
145	127	48	3C-117-A24	3C-17-K24
140	120	47	3C-118-A24	3C-18-K24
240	204	80	3C-119-A24	3C-19-K24
325	280	115	3C-120-A24	3C-20-K24
345	295	120	3C-121-A24	3C-21-K24
480	410	160	3C-122-A24	3C-22-K24
575	500	200	3C-123-A24	3C-23-K24
630	540	230	3C-124-A24	3C-24-K24
360	310	125	3C-125-A24	3C-25-K24
204	175	65	3C-126-A24	3C-26-K24
110	95	38	3C-127-A24	3C-27-K24
650	560	240	3C-128-A24	3C-28-K24
185	157	60	3C-133-A24	3C-33-K24
63	54	20	3C-134-A24	3C-34-K24
79	68	26	3C-135-A24	3C-35-K24
76	65	25	3C-136-A24	3C-36-K24

EXPORT COILS

14	12	4.8	3CE-106-A24	3CE-6-K24
28	24	9.5	3CE-109-A24	3CE-9-K24
57	48	19	3CE-112-A24	3CE-12-K24
128	110	42	3CE-116-A24	3CE-16-K24
255	220	90	3CE-119-A24	3CE-19-K24
280	240	95	3CE-120-A24	3CE-20-K24
440	380	150	3CE-122-A24	3CE-22-K24
515	440	185	3CE-123-A24	3CE-23-K24

DIODE RECTIFIED COILS

120	110 & 120		3CD-116-A24	
240	220 & 240		3CD-130-A24	
24	24		3CD-131-A24	

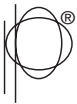

The coil chart shows applicable voltages for various frequencies. Specify voltages and frequencies as listed below when ordering. Consult factory for voltages and frequencies not listed.

SERIES 50 COIL CHART

A.C. VOLTAGES		D.C. VOLTAGES	NON-MOLDED COIL NO.	MOLDED COIL NO.
60 HZ.	50 HZ.			
6	5.4	3	5C-103-A24	5C-3-K24
7.8	7	3.8	5C-104-A24	5C-4-K24
8.5	7.7	4.4	5C-105-A24	5C-5-K24
12	11	6	5C-106-A24	5C-6-K24
14	13	7	5C-107-A24	5C-7-K24
18.5	17	9	5C-108-A24	5C-8-K24
24	22	12	5C-109-A24	5C-9-K24
32	29	16	5C-110A24	5C-10-K24
39	35	20	5C-111-A24	5C-11-K24
45	41	23	5C-112-A24	5C-12-K24
48	43	24	5C-113-A24	5C-13-K24
54	48	28	5C-114-A24	5C-14-K24
94	85	47	5C-115-A24	5C-15-K24
120	110	60	5C-116-A24	5C-16-K24
153	138	76	5C-117-A24	5C-17-K24
208	185	100	5C-118-A24	5C-18-K24
240	215	120	5C-119-A24	5C-19-K24
348	312	180	5C-120-A24	5C-20-K24
480	432	253	5C-121-A24	5C-21-K24
520	467	275	5C-122-A24	5C-22-K24
575	515	300	5C-123-A24	5C-23-K24
392	354	200	5C-124-A24	5C-24-K24
62	55	33	5C-127-A24	N/A
70	63	36	5C-130-A24	5C-30-K24
176	165	90	5C-131-A24	5C-31-K24
16	15	7.8	5C-132-A24	N/A
245	215	115	5C-141-A24	5C-41-K24

EXPORT COILS

6.7	6	3.5	5CE-104-A24	5CE-4-K24
13	12	7	5CE-107-A24	5CE-7-K24
26	24	14	5CE-110-A24	5CE-10-K24
100	91	49	5CE-115-A24	5CE-15-K24
111	100	57	5CE-116-A24	5CE-16-K24
141	127	72	5CE-117-A24	5CE-17-K24
223	200	118	5CE-119-A24	5CE-19-K24
245	220	125	5CE-120-A24	5CE-20-K24
270	240	143	5CE-121-A24	5CE-21-K24
425	380	230	5CE-122-A24	5CE-22-K24
490	440	252	5CE-123-A24	5CE-23-K24
256	230	139	5CE-124-A24	5CE-24-K24
460	415	240	5CE-125-A24	5CE-25-K24

DIODE RECTIFIED COILS

24	24		5CD-109-A24	
100	115/400Hz		5CD-116-A24	
240	220 & 240		5CD-119-A24	
120	110 & 120		5CD-124-A24	

DUAL VOLTAGE

120/240			5C-125-B24	
240/480			5C-126-B24	

The coil chart shows applicable voltages for various frequencies. Specify voltages and frequencies as listed below when ordering. Consult factory for voltages and frequencies not listed.

SERIES 70 COIL CHART

A.C. VOLTAGES		D.C. VOLTAGES	NON-MOLDED COIL NO.	MOLDED COIL NO.
60 HZ.	50 HZ.			
12	11	2.5	7C-101-A24	7C-1-K24
16	14	3.3	7C-102-A24	7C-2-K24
24	21	5	7C-103-A24	7C-3-K24
28	25	6	7C-104-A24	7C-4-K24
			7C-105-A24	7C-5-K24
41	37	8	7C-106-A24	7C-6-K24
48	43	10	7C-107-A24	7C-7-K24
55	49	12	7C-108-A24	7C-8-K24
97	87	20	7C-109-A24	7C-9-K24
110	98	24	7C-110-A24	7C-10-K24
120	110	26	7C-111-A24	7C-11-K24
140	124	28	7C-112-A24	7C-12-K24
150	135	32	7C-113-A24	7C-13-K24
240	220	50	7C-114-A24	7C-14-K24
204	182	46	7C-115-A24	7C-15-K24
395	355	82	7C-116-A24	7C-16-K24
480	430	100	7C-117-A24	7C-17-K24
540	485	120	7C-118-A24	7C-18-K24
575	515	125	7C-119-A24	7C-19-K24
1050	940	220	7C-120-A24	7C-20-K24
159	143	36	7C-121-A24	7C-21-K24
1150	1035	250	7C-122-A24	7C-22-K24
315	287	67	7C-123-A24	7C-23-K24
338	307	72	7C-124-A24	7C-24-K24
960	860	198	7C-125-A24	7C-25-K24

EXPORT COILS

13	12	2.7	7CE-102-A24	7CE-2-K24
26	24	5.3	7CE-104-A24	7CE-4-K24
53	48	11.5	7CE-107-A24	7CE-7-K24
100	90	21	7CE-109-A24	7CE-9-K24
112	100	25	7CE-110-A24	7CE-10-K24
140	127	30	7CE-113-A24	7CE-13-K24
255	230	53	7CE-114-A24	7CE-14-K24
265	240	60	7CE-115-A24	7CE-15-K24
420	380	92	7CE-116-A24	7CE-16-K24
490	440	102	7CE-117-A24	7CE-17-K24
225	204	48	7CE-120-A24	7CE-20-K24

DIODE RECTIFIED COILS

24	24		7CD-108-A24	
	115/400 Hz		7CD-114-A24	
120	110 & 120		7CD-115-A24	
240	220 & 240		7CD-118-A24	

Valve Temperature Range: STANDARD VALVES – 0°F (-18°C) to 104°F (40°C) ambient; 0°F (-18°C) to 150°F (65°C) media. OPTIONAL VALVES – can tolerate much higher or much lower ambient and media temperatures. Consult factory for specifics.

AVAILABLE OPTIONS

HOUSING & COIL OPTIONS	OPTION CODE	SERIES					COMMENTS
		15	20	30	50	70	
Strain Relief Connector	Q		✓	✓	✓	✓	Standard no-molded – Others Consult Factory
Single Automotive	AS		✓	✓		✓	Requires potting – Consult Factory
Double Automotive	AD		✓			✓	Requires potting – Consult Factory
“AN” Connector (2 Wire)	S		✓	✓	✓	✓	Recommended potting/other option – Consult Factory
J.I.C. Housing	J		✓				
Yoke – For Leads	Y		✓	✓	✓		Non-molded coil or Molded
Mounting Bracket	B	✓	✓	✓	✓	✓	Series 20 E.P. Special - Consult Factory
Splice Box	N		✓	✓	✓	✓	
Metered Exhaust Port	U		✓	✓			
Metered Exhaust Adapter	—		✓	✓			
Built-in Muffler	V	✓	✓	✓	✓	✓	(For use with valve adapter)
Potted Coil in Housing	P		✓	✓	✓	✓	
Spade Terminal Coil – Molded	KM		✓	✓	✓	n/a	
Universal Mounting Bracket	20-2416	✓	✓	✓	✓	n/a	
Universal Bracket Top Mount	B96	✓	✓	✓	✓	✓	
3RD Wire Ground	CC		✓	✓	✓	✓	
Weather Proof Seal	W		✓	✓	n/a	n/a	
Aluminum Shading Rings	A	✓	✓	✓	✓	✓	
Silver Shading Rings	S	✓	✓	✓	✓	✓	Consult Factory for price fluctuations
Series E 50 All Stainless Steel Explosion Proof Option					✓		Consult Factory for details
Series EL 50 Explosion Proof Low Watt Option					✓		Consult Factory for details
Series EL 50 Stainless Steel Explosion Proof Low Watt Option					✓		Consult Factory for details
Series ELL-50 Extra Low Watt Option					✓		Consult Factory for details
Time Option Net Adder Any Quantity			✓				S-20 European Coil. Consult Factory.

VALVE BODY & PORT OPTIONS

Consult factory for minimum quantities

	OPTION CODE	SERIES					COMMENTS
		15	20	30	50	70	
Metering to 1/8" Orifice	T		✓	✓	✓	✓**	
Metering to 1/4" Orifice	F		✓			✓	
Metered Bypass	W		✓			✓	
Manual Override	Y		✓*			✓	
Bottom Orifice Port	R		✓	✓	✓	✓	
Bottom Cavity Port	O		✓	✓	✓	✓	
Port 90° Left	M		✓	✓		✓	
Manifold Mount	E	†	✓	✓	✓	✓	
Flange mount	H		✓			✓	
Port 90° Right	L		✓	✓			
Gang Feeding (3 Ported Body)	G		✓	✓			
10/32 Ports					✓		

* Manual override not available in high pressure - Series 20 valves.

** Possible only with 3/32 & 1/8 Orifice. (Restricts flow with 1/8 orifice.)

† Square aluminum body-top mounting. (Consult factory.)

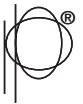

SOLENOID OPERATORS

Numbering System Chart for Solenoid Operators

1st Digit	2nd Digit	3rd Digit	4th Digit	5th Digit	6th Digit	7th Digit	8th Digit	9th Digit
Operator Series Design	Type	Orifice	Sleeve Housing & Flux Plate Combination	Sleeve Option	Housing Options	Coil Options	VOLTAGE	FREQUENCY
O2-SER.20 OE2-Explosion Proof O3-SER. 30 O4-SER. 40 O5-SER. 50 OE5-Explosion Proof O7-SER. 70 OELW5S-Ser 50 OELS-Ser 50	1-2WNO 2-2WNC 3-3WNC 4-3WNO 5-Dir. Cont 6-Multi Purpose	G-1/32 H-3/64 J-1/16 K-3/32 L-7/64 N-1/8 O-5/32 P-3/16 U-7/32 R-1/4 S-5/16 T-3/8 V-5/64	A-Series 20 Only (Magnetic Body w/shoulder 1 9/16 Housing "A" Stop) B-Series 20 Only (Non-Magnetic Body w/shoulder 1 11/16 Housing Heavy Flux Plate "B" Stop) C-Series 20 Only (Magnetic or Non-Magnetic Body Flush Mounting 1 9/16 Housing Heavy Flux Plate "B" Stop)\ D-Series 15, 30, 50, 70, OE & J.I.C. Operators Only E-Series 20 (Magnetic or Non-Magnetic Body 1 7/16 Housing, Light Flux Plate "B" Stop) F-Series 20 Any Body KM Yoke "C" Stop	D-No Option U-Metered Exhaust Z-1/4" Sleeve Port Adapter X-1/8" Sleeve Port Adapter W-Spacer (Series 50 Only) UX-1/8" NPT Metered Port Adapter UZ-1/4" NPT Metered Port Adapter	B-Mounting Bracket C-Conduit G-Grommet J-J.I.C. Housing S-"AN" Connector Q-Strain Relief Y-Yoke AS-Single Automotive Housing AD-Double Automotive Housing N-Splice Box Housing K-Yoke for Spade Terminal Coil CC-Conduit w/3rd Wire Ground E-European Style Coil (DIN) V-E x H Muffler	V-Non Molded M-Molded H-High Temp. 180° C-High Temp. over 180° D-Diode Coil (STD) R-Diode Coil (Full Wave Bridge) P-Potted Coil (STD Temp) F-Potted Coil (Class H) Additional Options A-Aluminum Shading Ring S-Silver Shading Ring B-Non Molded (Series 50 only)	We Require full description Example: 120 or 240 volts	In A.C. application give full details Example: 60 or 50 HZ

EXMAPLE:
O23NKAZBCM-120/60

O2	3	NK	A	Z	B C	M	120	60
SER.20 Valve Operator	3-Way Normally Closed Valve	1/8" Inlet 3/32 Exhaust Orifice	Series 20 Only (Magnetic w/Shoulder 19/16 Housing)	1/4" Sleeve Port Adapter	Bracket Conduit Housing	Molded Coil	120 Volt Line	A.C. 60 Hertz

Numbering System Chart for Series 58

1st Digit	2nd Digit	3rd Digit	4th Digit	5th Digit	6th Digit	7th Digit	8th Digit
Power Level	Type***	Orifice*	Port Body Options	Function Options	Coil Options	Voltage	Frequency
Blank: Standard 3.5 watt rating	581-2WNO 582-2WNC 583-3WNC 584-3WNO	A-.6 MM F-.8MM M-1.0MM W-1.2MM	15 Manifold Mount 16 Manifold Mount with Manual Override	D-No Options P-10-32 Sleeve Adapter	G-Molded with Lead Wire E-Molded with Micro DIN	Full Description Required Example: 24 or 120 Volts	For A.C. Applications, give full details Example: 60 or 50 Hertz
L-Low Watt (.9 watt) version (DC only)	585-3WDC (Directional Control) 586-3WMP (Multi-Purpose)	Y-1.4MM (Metal body only) J-1.6MM (Metal body only)	19 10-32 Ports plastic 21 10-32 Ports S.S.(430F) 22 10-32 Ports Brass 23 10-32 Ports S.S.(303F) 24 10-32 spud mount S.S.(430F) 25 10-32 spud mount brass 26 10-32 spud mount S.S(303)				
S-Extended PSI rates for metal bodies/housing only			27 M5 ports S.S. (430F) 28 M5 ports brass 29 M5 ports S.S.(303)				

EXAMPLE

58 Series 58 Valve	3 3-Way Normally Closed	AF .6MM Inlet .8MM Exhaust Orifice	16 Manifold Mount with Manual Override	P 10-32 Sleeve Adapter	G Lead Wire	120 120 Volt Line	60 A.C. 60 Hertz
--------------------------	----------------------------------	--	---	------------------------------	----------------	----------------------	---------------------

NOTE: "L" Marked Prior to numbers denots Low Watt

* For 3 way valves, this digit will consist of two suffix letters. First suffix indicates inlet orifice; second indicates exhaust orifice.

SPECIFICATIONS ARE SUBJECT TO CHANGE WITHOUT NOTICE.

Numbering System Chart -All Valves Except Series 58

1st Digit	2nd Digit	3rd Digit	4th Digit	5th Digit	6th Digit	7th Digit	8th Digit	9th Digit
Series Designation	Type	Orifice*	Port Size And Body Material	Body Port and Function Options	Housing Options	Coil Options	Voltage	Frequency
2 - Series 20 3 - Series 30 4 - Series 40 5 - Series 50 7 - Series 70 8 - Series 80	1 - 2WNO 2 - 2WNC 3 - 3WNC 4 - 3WNO 5 - 3WDC 6 - 3WMP 18 - Direct Lift 2WNO 27 - Direct Lift 2WNC 28 - Pilot Lift 2WNC	G - 1/32 H - 3/64 J - 1/16 K - 3/32 L - 7/64 N - 1/8 O - 5/32 P - 3/16 U - 7/32 R - 1/4 A - 9/32 S - 5/16 T - 3/8 V - 5/64 B - 1/2 C - 5/8 D - 1" E - 1 1/2" Y - 3/4 F - 2 W - 3	SS BR AL 1/8 NPT 7 4 2†† 1/8 NPT 8 5 2 1/4 NPT 9 6 3 3/8 NPT 1 10 1/2 NPT 33 12 11 1 NPT 23 13 1 1/2 NPT 24 14 3/4 NPT 29 19 2 NPT 26 16 2 1/2 NPT 27 17 3" NPT 28 18 1/8 Male NPT BR 31 1/4 Compression 32 1/8 NPT Plastic 15 E - Manifold Mount H - Flange Mount F - Brass Hex Stud Mount Manifold Body N - SS Hex Stud Mount Manifold Body	D - No Option Ports T - Metering (1/32 - 1/8 orif.) F - Metering Series 70 (5/32 - 1/4 orif.) **** Y - Manual Override W - Metered By-Pass U - Metered Exhaust V - Exh. Port Muffled R - Bottom Orifice Port O - Bottom cavity Port M - 90° Left Port L - 90° Right Port Z - 1/4 NPT sleeve port X - 1/8 NPT sleeve port UX - 1/8 NPT metered adapter UZ - 1/4 NPT metered adapter Series 50 T - Bottom Metering F - Side Metering	B - Mounting Bracket C - Conduit G - Grommet J - JIC Housing S - AN Connector Q - Strain Relief Connector Y - Yoke ††† K - Yoke for Spade Terminal AS - Single Automotive Housing AD - Double Automotive Housing CC - Conduit with third wire ground N - Splice Box E - Export Connector	V - Non Molded M - Molded H - High Temp. 180° C P - Potted Coil & Housing B - Non Molded (Series 50) D - Diode Rectified Coil R - Diode Bridge F - High Temp. Potted Additional Options: A - Aluminum Shading Ring S - Silver Shading Ring G - Gas† L - Liquid† LM - Latching Molded Coil	We Require the full descript. Example 120 or 240 50 HZ or 60 HZ in a DC appl. state DC	In an AC appl. give full details Example 50 HZ or 60 HZ in a DC appl. state DC

EXAMPLE

2	3	N K	9	Y	Z	C	M	120	60
Series 20 Valve	3 way Norm. Closed	1/8 Inlet 3/32 Exhaust	Stainless Steel Valve Body 1/4" NPT Ports	Manual Override	1/4" NPT	Conduit Housing	Molded Coil	120 Volt Line	AC 60 Hertz

NOTE: "G" Marked prior to the valve number denotes Gang Feeding.
 "E" Marked prior to the valve number denotes Explosion Proof.
 "H" Marked prior to the valve number denotes High Pressure Valve.
 "F" Marked prior to the valve number denotes Filter Valve.

Where numerous options are specified, valves will be marked with 2 numbers to identify valve series and type, followed by specifically assigned numbers.

* For 3 way valves this number will consist of two suffix letters. The first indicates the inlet orifice & the second the exhaust orifice.

** For valves with a combination of two standard body options, this suffix will consist of two letters.

**** In Series 70 -1/16 - 5/16 Orifice.

† For series H high pressure valves only.

†† 2 in Series 15 is 1/8 NPT Aluminum only.

††† Letter K followed by "M" in 7th digit column indicates molded spade terminal coil & yoke.

SPECIFICATIONS ARE SUBJECT TO CHANGE WITHOUT NOTICE.

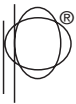

SPECIFICATION FORM 003A

Please fill in all parts of this form. If data for a part is unknown, mark "unknown". This completed form will enable us to recommend the most appropriate and economical valve for your application.

Customer Name Date
Address City/State
Individual Title
Application O.E.M. User
Estimated Quantity Now Yearly Use other side for additional Information
Phone Fax E-Mail

GENERAL SPECIFICATIONS

VALVE TYPE

- Two Way
- Three Way
- Four Way

FUNCTION

- Normally open
- Normally closed
- Directional control
- Multi-purpose

ELECTRICAL OUTLET

- 1/2" NPT conduit (C)
- 1/4" NPT conduit (C)
- Grommet (G)
- European DIN connector
- Other

FLUID CONNECTION

- 1/8" NPT
- 1/4" NPT
- 3/8" NPT
- Other

Catalog option features (if required)
 Explosionproof construction, UL Class I, Groups A, B, C & D; Class II, Groups E, F, And G, consult factory

VOLTAGE

- ACMaxMin.
.....Cycles
- DCMaxMin.

DUTY CYCLE

- Continuous duty (energized for more than one hour)
Time energizedhours. Time de-energizedhours
- Intermittent duty (energized for less than one hour)
Max. time energizedminutes. Min. Time de-energizedminutes

ORIFICE SIZE

InletDia, or C_v
ExhaustDia, or C_v

CYCLING DATA

Operating speedCPM

LIFE EXPECTANCY

Total cycles per year
Number of years

FLOW RATE

Gases:SCFM @ inlet pressure
ofPSIG and outlet pressure ofPSIG
Liquids:GPM @ inlet pressure
ofPSIG and outlet pressure ofPSIG

AMBIENT CONDITIONS

- Temperature °FMax.Min.
- High humidity and condensation
- Other

PRESSURE OR VACUUM

Maximum static pressurePSIG
Maximum vacuuminches of Hg
Maximum operation pressure differentialPSI
Maximum back pressurePSIG
Minimum operating pressure differentialPSI

ALLOWABLE INTERNAL LEAKAGE

None cc/minute atPSID

VIBRATION AND SHOCK

- Not a factor
- VibrationCPS atG's
- ShockG's duration formilliseconds
in Vertical plane Horizontal plane

MEDIA BEING HANDLED

Description
if gas Lubricated Non lubricated
Temperature °FMax,Min.
Viscosity
(If over No. 10 SAE oil or 100 SSU at 100°F)

APPROVAL REQUIRED

- None
- UL listing UL component listing
- Other (CSA, FM, etc.)

Form completed by: NameCompany
PETER PAUL ELECTRONICS recommendation: Valve number or description
.....NameDate

FOR CONVENIENT VALVE SPECIFICATION

THIS PAGE CAN BE CUT OUT AND SENT IN

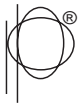

**PETER
PAUL**

The Founders of Peter Paul



Paul Mangiafico



Josephine Mangiafico

The Family History that's Your Valve Advantage

Peter Paul continues its history as a driving force in solenoid valves since 1947. Founded as a family business by Paul and Josephine Mangiafico right after World War II, the company is currently managed by first, second and third generation family members in a range of responsibilities. What this means for you is that the people with whom you deal today will be there to answer to you tomorrow.

This family commitment ensures that you get personal attention from a company sized to address your needs. Peter Paul has grown with the demand for its high service philosophy, quadrupling its plant from 7,000 to 28,000 square feet in 1977. By 1988, the company had grown to 130 employees and 77,000 square feet.

Now, you get a company whose size and manufacturing capabilities ensure innovation and quality with rapid response. Beyond that, you can always talk with a family member to ensure optimum satisfaction because at Peter Paul, customer retention starts with the family.

To see a complete listing of our distributors,
visit our website at www.peterpaul.com



**PETER
PAUL**

electronics co., inc.

Warranty

Peter Paul Electronics Co., Inc. (seller) warrants its products to be free from defects in workmanship and material. Under normal use and service, Peter Paul products will perform very satisfactorily. The seller's obligation under this warranty shall be limited to the repairing, free of charge, any part or valve which, after his examination, shows it to be defective. Of course, normal wear and tear must be considered and exempted. No representative or person is authorized to assume for the seller any other obligation or liability in connection with the sale of its products.

All engineering and technical advice are offered free of charge, in a spirit of helpfulness to the buyer. This assistance is based on data which Peter Paul considers reliable and is intended to be used by knowledgeable and skillful personnel at their own risk.

The seller shall not be liable for consequential damages in case of failure to meet conditions of any guarantee or shipping schedule, nor claims for labor, loss of profits, repairs or other expenses incidental to replacement.



PO Box 1180
480 John Downey Drive
New Britain, CT 06050-1180
Tel/ 860.229.4884 Fax/ 860.223.1734
DUNS/ 00.116.0571 info@peterpaul.com
www.peterpaul.com

